

ALLEY PAVEMENT PROFILE
SCALE: 1:250 HOR
1:10 VER

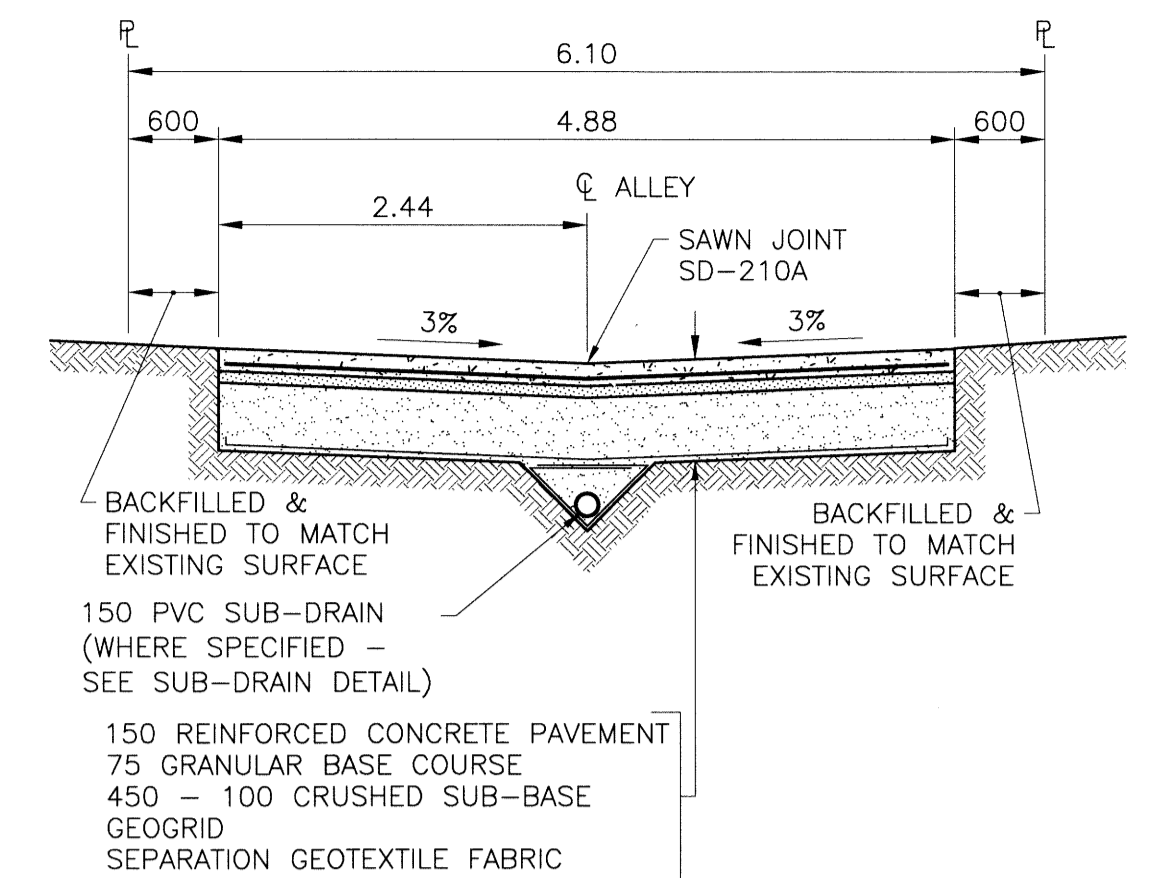

TYPICAL CROSS SECTION
SCALE: 1:50

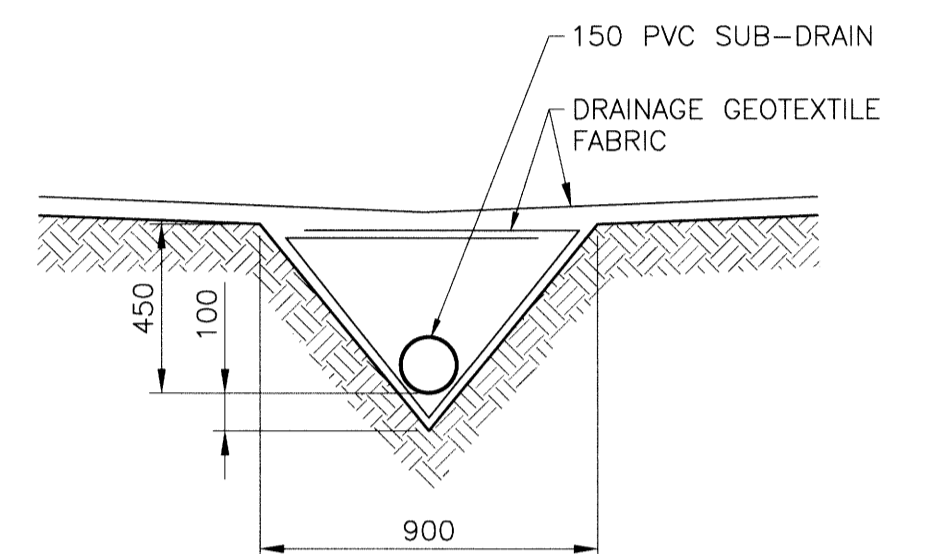

SUB-DRAIN DETAIL
SCALE: 1:20

NOTES:

1. STATION CHAINAGE IS BASED ON CENTERLINE OF ALLEY RIGHT OF WAY.
2. ADJUST MH AND CB RIMS TO NEW GRADES.
3. PLUG SUB-DRAINS AT TERMINAL ENDS.
4. REGRADE EXISTING PRIVATE SIDEWALKS AS REQUIRED.
5. INSTALLATION OF LIP CURBS AND THEIR EXTENTS TO BE DETERMINED BY THE CONTRACT ADMINISTRATOR.
6. LIGHT STANDARDS, HYDRO POLES AND ANCHORS MAY REQUIRE TEMPORARY SUPPORT/REMOVAL OR REPLACEMENT AT THE CONTRACTOR'S EXPENSE.
7. ISOLATE ALL POLES, BASES AND PILES WITHIN ALLEY RIGHT OF WAY (SD-228C)
8. AVOID DAMAGE TO EXISTING TREES WITHIN THE LIMITS OF CONSTRUCTION
9. CITY OF WINNIPEG SURVEY MONUMENTS EXIST ON THIS SITE. CONTRACTOR TO CONTACT THE CITY OF WINNIPEG GEOMATICS BRANCH 5 WORKING DAYS IN ADVANCE OF CONSTRUCTION TO COORDINATE MONUMENT PROTECTION SERVICES (204-918-1360)

WARNING

NOTIFY THE GAS COMPANY OF THE PROPOSED LOCATION OF EXCAVATION. TAKE PRECAUTION TO AVOID DAMAGE TO GAS COMPANY INSTALLATIONS. SEE PROVINCIAL REGULATION 210/72 FOR DETAILS.

METRIC

WHOLE NUMBERS INDICATE MILLIMETRES
DECIMALIZED NUMBERS INDICATE METRES

PROPERTY LIMITS DELINEATION

DELINEATION OF PROPERTY LIMITS AS SHOWN ON THIS DWG DOES NOT REPRESENT A "LEGAL SURVEY". KGS GROUP MAKES NO REPRESENTATION OR WARRANTY AS TO THE ACCURACY OF PROPERTY LIMITS DELINEATED ON THIS DWG, NOR ON THE DIMENSIONAL ACCURACY OF DWG FEATURES RELATIVE TO THOSE PROPERTY LIMITS.

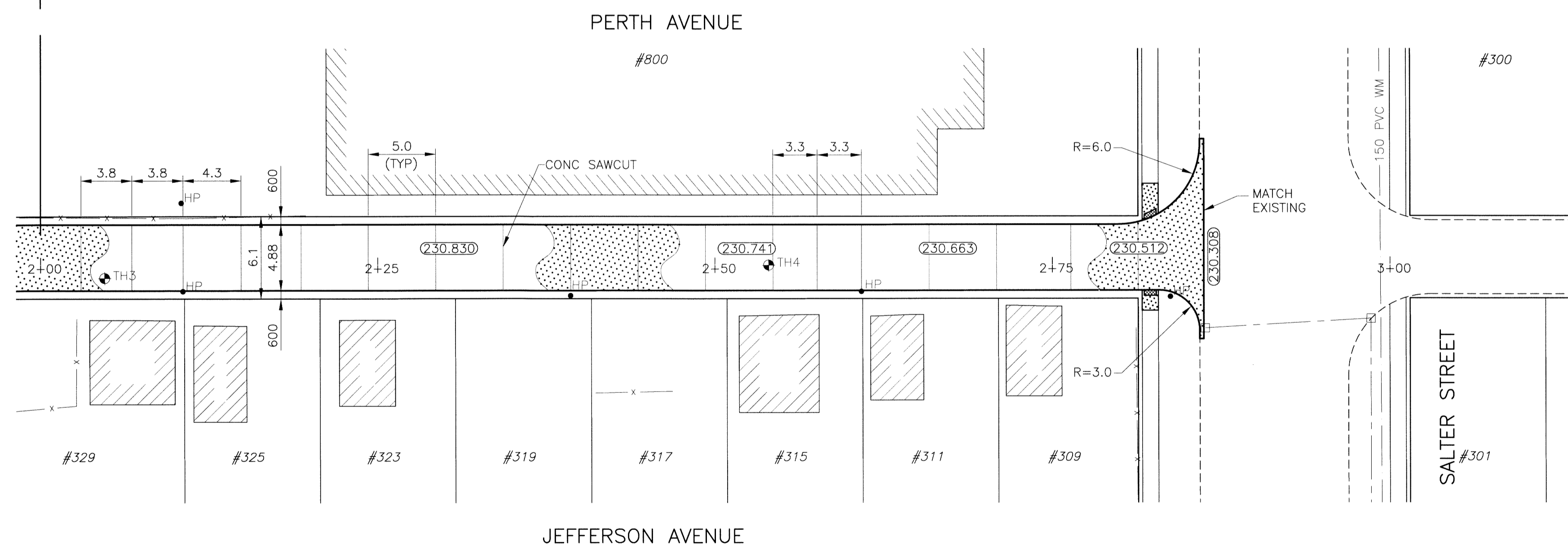

ALLEY PAVEMENT PLAN
SCALE: 1:250 HOR

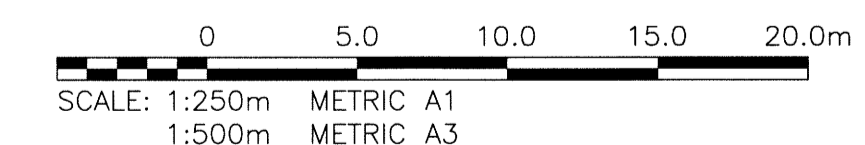
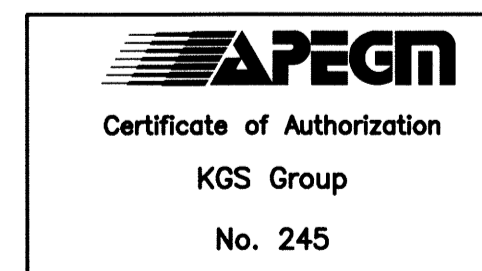
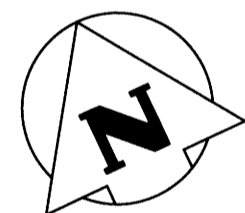

EXISTING	LEGEND-PLAN	PROPOSED	EXISTING	LEGEND-PLAN	PROPOSED	EXISTING	LEGEND-PROFILE	PROPOSED
---	LAND DRAINAGE SEWER	---	+	TEST HOLE	+	---	---	---
---	WASTE WATER SEWER	---	+	GUY WIRE	+	---	---	---
---	GAS	---	+	LIGHT STANDARD	+	---	---	---
---	HYDRO	---	+	BACK OF CURB	+	---	---	---
---	M.T.S.	---	+	CONCRETE	+	---	---	---
---	WATERMAIN	---	+	ASPHALT	+	---	---	---
+	HYDRANT	+	+	SIDEWALK	+	---	---	---
+	VALVE	+	+	PROPERTY LINE	+	---	---	---
+	MANHOLE	+	+	SURVEY BAR	+	---	---	---
+	CATCH BASIN	+	+	GEODETIC BENCHMARK	+	---	---	---
+	CURB INLET	+	+	ELEVATION	+	---	---	---
+	POLES	+	+		+	---	---	---

LOCATION APPROVED UNDERGROUND STRUCTURES

NOTE: LOCATION OF UNDERGROUND STRUCTURES AS SHOWN ARE BASED ON THE "BEST" INFORMATION AVAILABLE BUT NO GUARANTEE IS GIVEN THAT ALL EXISTING UTILITIES ARE SHOWN OR THAT THE GIVEN LOCATIONS ARE EXACT. CONFIRMATION OF EXISTENCE AND EXACT LOCATION OF ALL SERVICES MUST BE OBTAINED FROM THE INDIVIDUAL UTILITIES BEFORE PROCEEDING WITH CONSTRUCTION.

B.M. 13-00B ELEV. 231.283	S.W. Cor. Salter St. & Perth Ave., Tbt. in E. Conc. Foundation of West Kildonan Collegiate Institute, 2m S. & 0.2m below brick of N.E. Cor. of School.
DESIGNED BY: RBO	CHECKED BY: [Signature]
DRAWN BY: GEL/DMW	APPROVED BY: [Signature]
HOR. SCALE: 1:250	RELEASED FOR CONSTRUCTION:
VERTICAL: 1:50	DATE: 14/05/02

ISSUED FOR TENDER	14/07/05	CR
NO. REVISIONS	DATE	BY

KGS GROUP
CONSULTING ENGINEERS

ENGINEER'S SEAL
M.C. ROWBOTHAM
Member
22679
July 25, 2014

THE CITY OF WINNIPEG
PUBLIC WORKS DEPARTMENT
TRANSPORTATION ENGINEERING DIVISION

PROJECT TITLE: 2014 ALLEY RENEWAL PROGRAM CONTRACT 2
JEFFERSON AVE/PERTH AVE
POWERS ST TO SALTER ST
STA 2+00 TO SALTER ST

SHEET 02 OF 17
COMPUTER FILE NAME: 13-0107-032_CALL
CITY DRAWING NUMBER: 0002