

P:\Projects\2013\13-0107-032\Dec.Control\JobBesaured\DWG\748-2014_Drawing_0004-Rev 0.dwg - Tab: C04 - Plotted By: DWeber 07/25/2014 [Fri 10:05am]

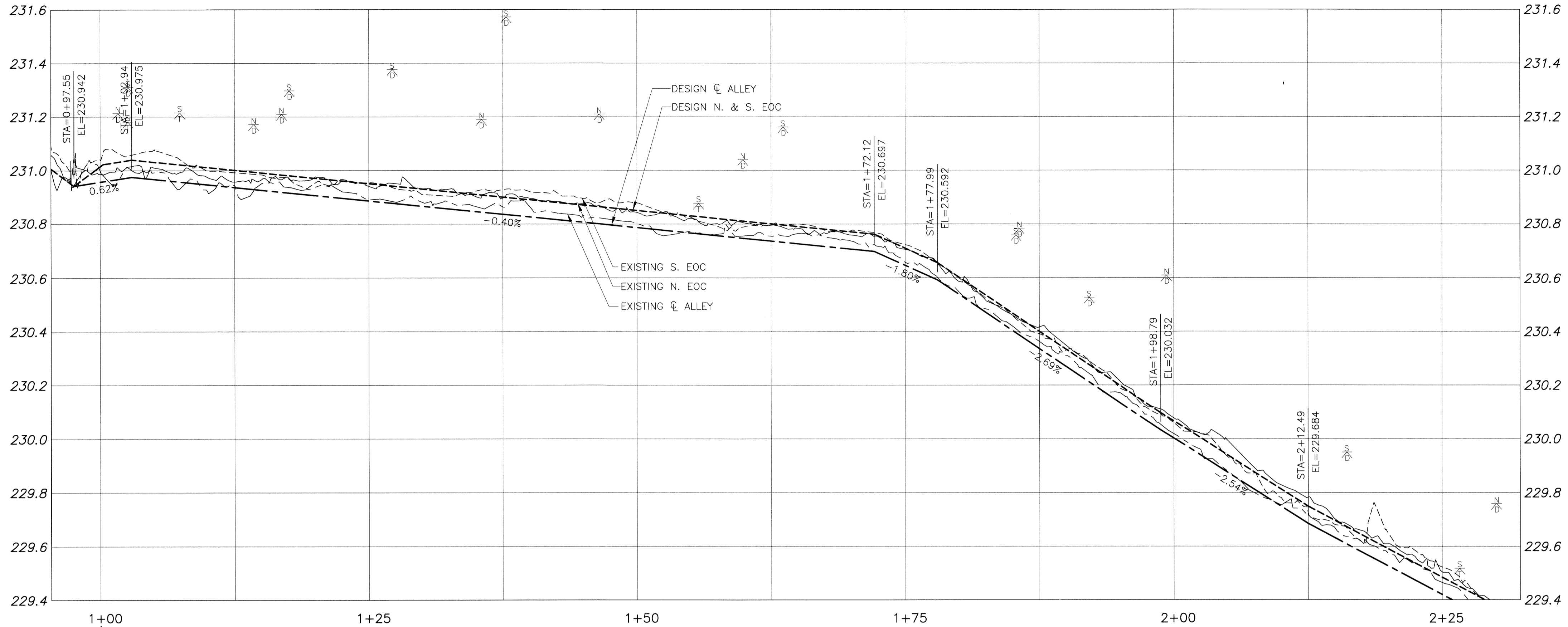

ALLEY PAVEMENT PROFILE
 SCALE: 1:250 HOR
 1:10 VER

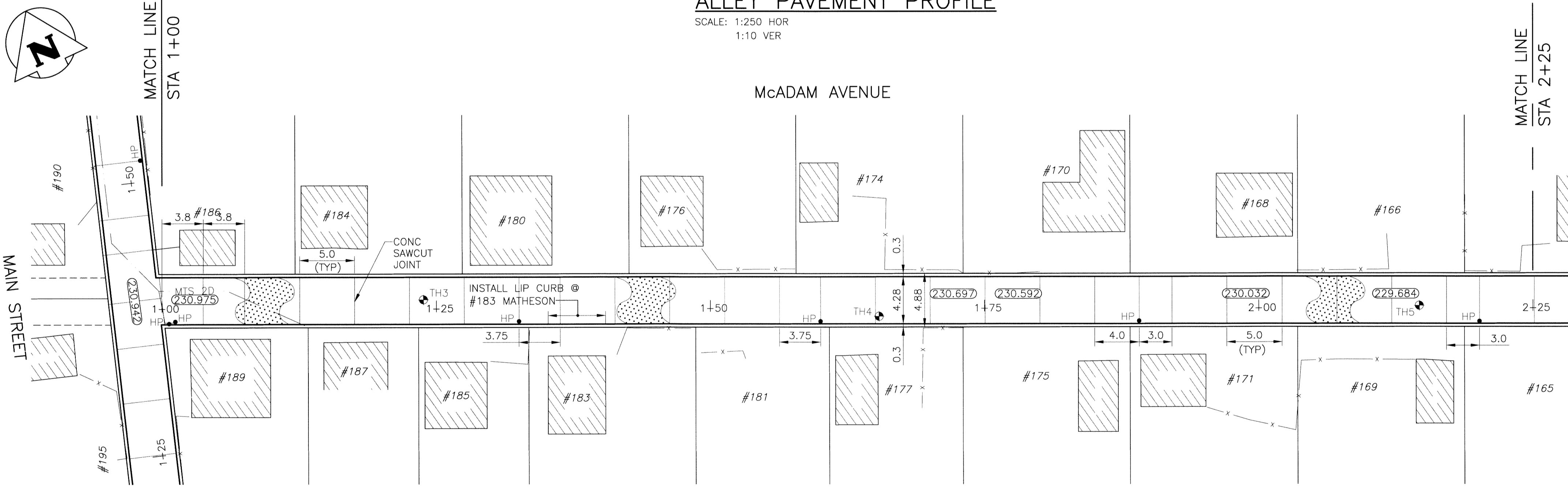

ALLEY PAVEMENT PLAN
 SCALE: 1:250 HOR

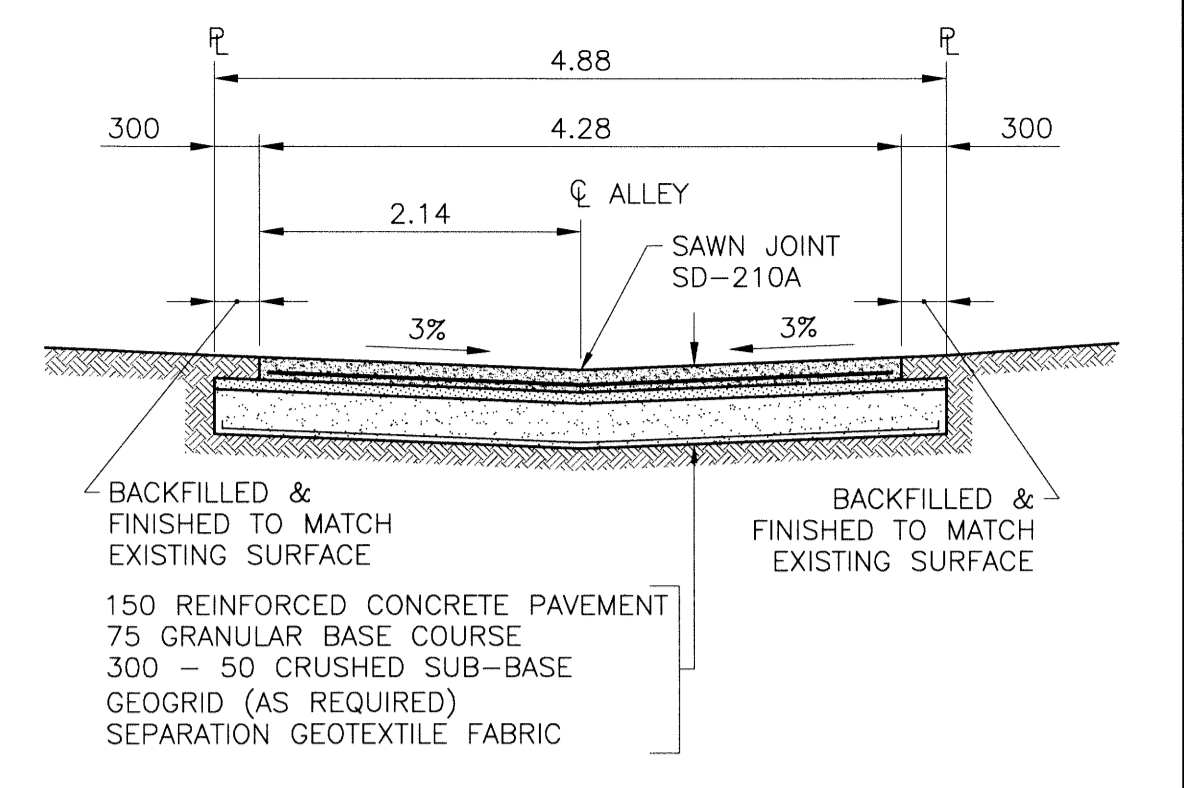

TYPICAL CROSS SECTION
 SCALE: 1:50

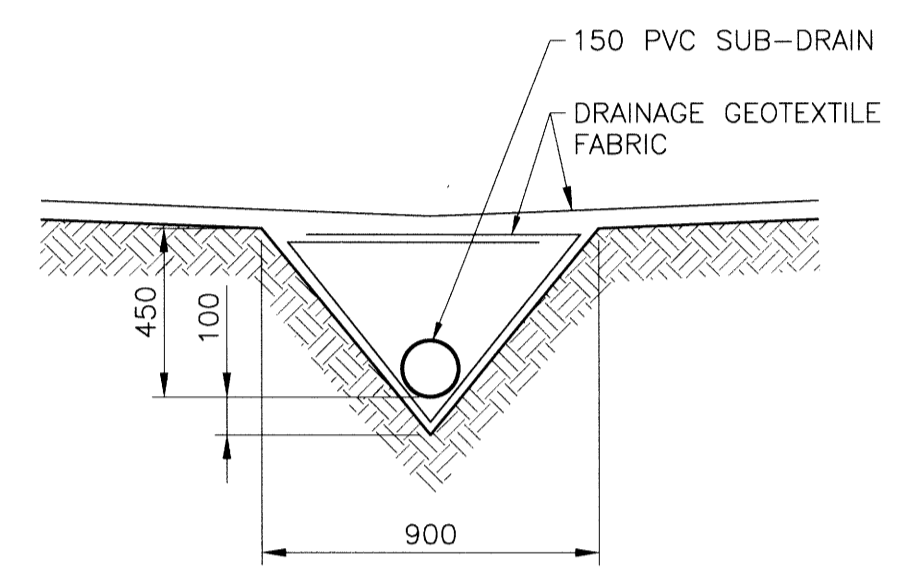

SUB-DRAIN DETAIL
 SCALE: 1:20

- NOTES:**
1. STATION CHAINAGE IS BASED ON CENTERLINE OF ALLEY RIGHT OF WAY.
 2. ADJUST MH AND CB RIMS TO NEW GRADES.
 3. PLUG SUB-DRAINS AT TERMINAL ENDS.
 4. REGRADE EXISTING PRIVATE SIDEWALKS AS REQUIRED.
 5. INSTALLATION OF LIP CURBS AND THEIR EXTENTS TO BE DETERMINED BY THE CONTRACT ADMINISTRATOR.
 6. LIGHT STANDARDS, HYDRO POLES AND ANCHORS MAY REQUIRE TEMPORARY SUPPORT/REMOVAL OR REPLACEMENT AT THE CONTRACTOR'S EXPENSE.
 7. ISOLATE ALL POLES, BASES AND PILES WITHIN ALLEY RIGHT OF WAY (SD-228C)
 8. AVOID DAMAGE TO EXISTING TREES WITHIN THE LIMITS OF CONSTRUCTION
 9. CITY OF WINNIPEG SURVEY MONUMENTS EXIST ON THIS SITE. CONTRACTOR TO CONTACT THE CITY OF WINNIPEG GEOMATICS BRANCH 5 WORKING DAYS IN ADVANCE OF CONSTRUCTION TO COORDINATE MONUMENT PROTECTION SERVICES (204-918-1360)

WARNING
 NOTIFY THE GAS COMPANY OF THE PROPOSED LOCATION OF EXCAVATION. TAKE PRECAUTION TO AVOID DAMAGE TO GAS COMPANY INSTALLATIONS. SEE PROVINCIAL REGULATION 210/72 FOR DETAILS.

METRIC
 WHOLE NUMBERS INDICATE MILLIMETRES
 DECIMALIZED NUMBERS INDICATE METRES

PROPERTY LIMITS DELINEATION
 DELINEATION OF PROPERTY LIMITS AS SHOWN ON THIS DWG DOES NOT REPRESENT A "LEGAL SURVEY". KGS GROUP MAKES NO REPRESENTATION OR WARRANTY AS TO THE ACCURACY OF PROPERTY LIMITS DELINEATED ON THIS DWG, NOR ON THE DIMENSIONAL ACCURACY OF DWG FEATURES RELATIVE TO THOSE PROPERTY LIMITS.

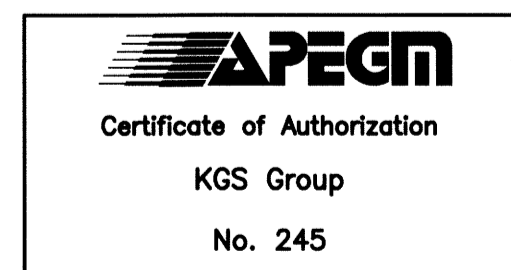
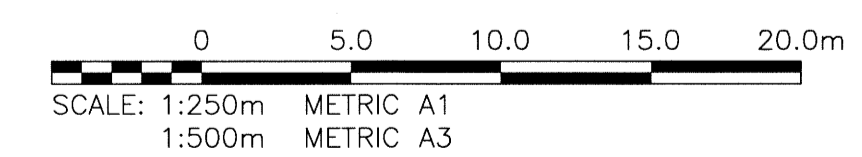

300_LBS	LAND DRAINAGE SEWER	300_LBS							
250_WWS	WASTE WATER SEWER	250_WWS	TEST HOLE						
	GAS		GUY WIRE						
	HYDRO		LIGHT STANDARD						
	M.T.S.		BACK OF CURB						
150_WM	WATERMAIN	150_WM	CONCRETE						
	HYDRANT		ASPHALT						
	VALVE		SIDEWALK						
	MANHOLE		PROPERTY LINE						
	CATCH BASIN		SURVEY BAR						
	CURB INLET		GEODETIC BENCHMARK						
	POLES		ELEVATION	231.334	(32.231)				
EXISTING	LEGEND-PLAN	PROPOSED	EXISTING	LEGEND-PLAN	PROPOSED	EXISTING	LEGEND-PROFILE	PROPOSED	

LOCATION APPROVED UNDERGROUND STRUCTURES

SUPV. U/G STRUCTURES DATE COMMITTEE

NOTE:
 LOCATION OF UNDERGROUND STRUCTURES AS SHOWN ARE BASED ON THE BEST INFORMATION AVAILABLE BUT NO GUARANTEE IS GIVEN THAT ALL EXISTING UTILITIES ARE SHOWN OR THAT THE GIVEN LOCATIONS ARE EXACT. CONFIRMATION OF EXISTENCE AND EXACT LOCATION OF ALL SERVICES MUST BE OBTAINED FROM THE INDIVIDUAL UTILITIES BEFORE PROCEEDING WITH CONSTRUCTION.

B.M. 26-043 ELEV. 232.044	W. side Main St. Btwn. Corruthers Ave. & McAdam Ave., Tbt. in E. Conc. foundation No. 1520 Main St. (Transit Base), 3m S. & 0.2m below brick of N.E. Cor. of bldg.
DESIGNED BY: RBO	CHECKED BY: [Signature]
DRAWN BY: GEL/DMW	APPROVED BY: [Signature]
HOR. SCALE: 1:250	RELEASED FOR CONSTRUCTION: [Date]
VERTICAL: 1:50	DATE: 14/05/02
ISSUED FOR TENDER: 14/07/25	BY: [Signature]
NO. REVISIONS	DATE

ENGINEER'S SEAL

M.C. ROWBOTHAM
 Member
 22679

JULY 25, 2014

CONSULTANT DRAWING NO.
13-0107-032_C04

THE CITY OF WINNIPEG
 PUBLIC WORKS DEPARTMENT
 TRANSPORTATION ENGINEERING DIVISION

PROJECT TITLE
2014 ALLEY RENEWAL PROGRAM

CONTRACT 2
McADAM AVE/MATHESON AVE E
MAIN ST TO COCHRANE ST
MAIN ST TO STA 2+25

SHEET OF
04 OF **17**

COMPUTER FILE NAME
13-0107-032_CALL

CITY DRAWING NUMBER
0004