

**ALLEY PAVEMENT PROFILE**

SCALE: 1:250 HOR  
1:10 VER

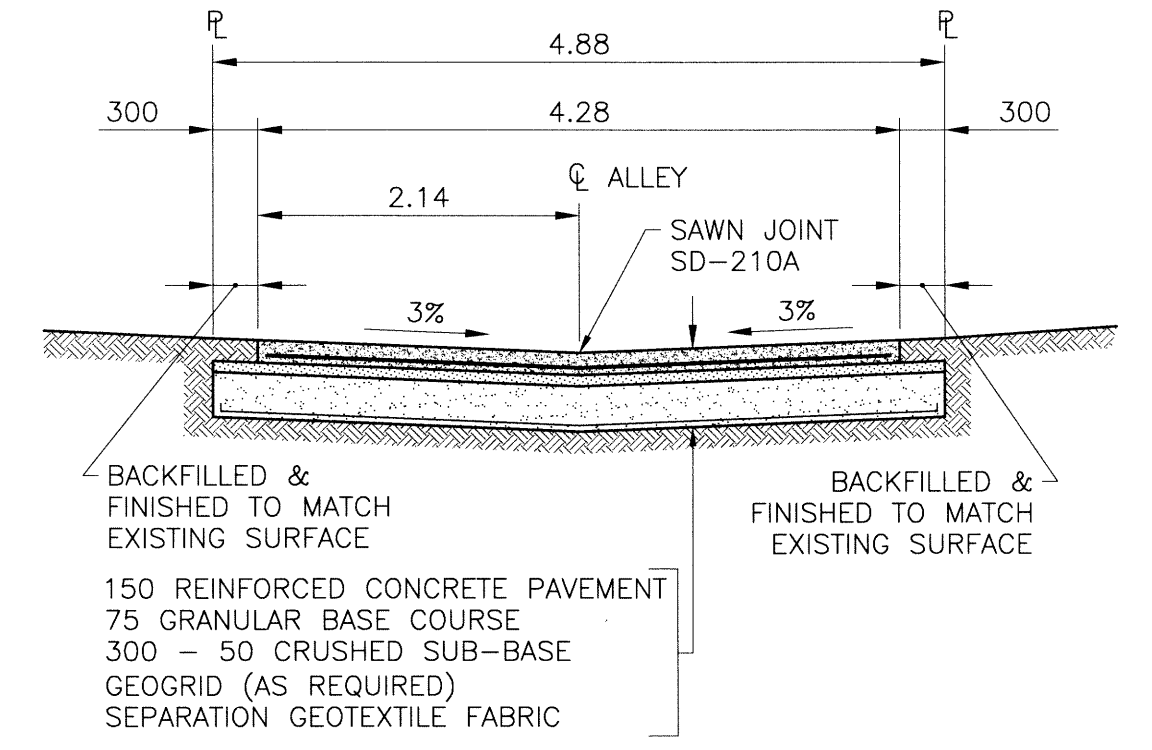

**TYPICAL CROSS SECTION**

SCALE: 1:50

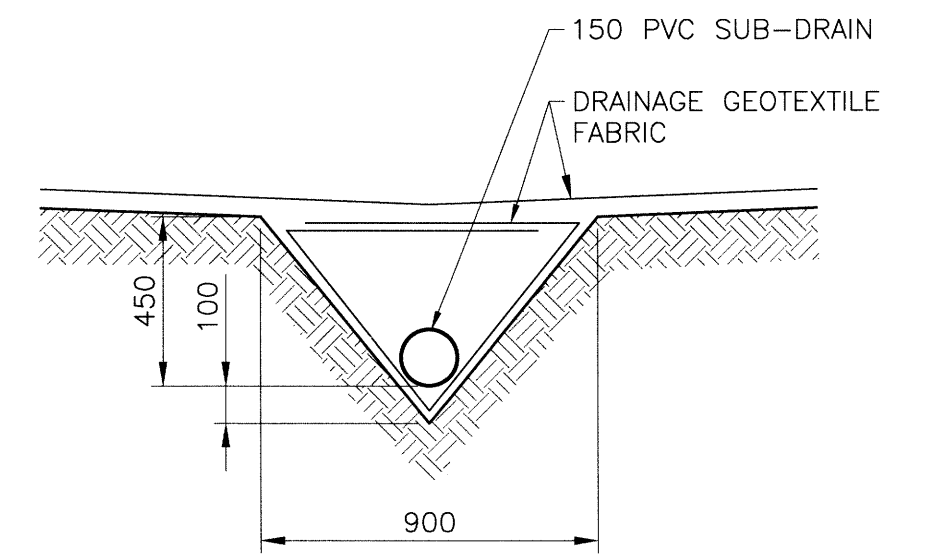

**SUB-DRAIN DETAIL**

SCALE: 1:20

**NOTES:**

- STATION CHAINAGE IS BASED ON CENTERLINE OF ALLEY RIGHT OF WAY.
- ADJUST MH AND CB RIMS TO NEW GRADES.
- PLUG SUB-DRAINS AT TERMINAL ENDS.
- REGRADE EXISTING PRIVATE SIDEWALKS AS REQUIRED.
- INSTALLATION OF LIP CURBS AND THEIR EXTENTS TO BE DETERMINED BY THE CONTRACT ADMINISTRATOR.
- LIGHT STANDARDS, HYDRO POLES AND ANCHORS MAY REQUIRE TEMPORARY SUPPORT/REMOVAL OR REPLACEMENT AT THE CONTRACTOR'S EXPENSE.
- ISOLATE ALL POLES, BASES AND PILES WITHIN ALLEY RIGHT OF WAY (SD-228C)
- AVOID DAMAGE TO EXISTING TREES WITHIN THE LIMITS OF CONSTRUCTION
- CITY OF WINNIPEG SURVEY MONUMENTS EXIST ON THIS SITE. CONTRACTOR TO CONTACT THE CITY OF WINNIPEG GEOMATICS BRANCH 5 WORKING DAYS IN ADVANCE OF CONSTRUCTION TO COORDINATE MONUMENT PROTECTION SERVICES (204-918-1360)

**WARNING**

NOTIFY THE GAS COMPANY OF THE PROPOSED LOCATION OF EXCAVATION. TAKE PRECAUTION TO AVOID DAMAGE TO GAS COMPANY INSTALLATIONS. SEE DETAIL REGULATION 210/72 FOR DETAILS.

**METRIC**

WHOLE NUMBERS INDICATE MILLIMETRES  
DECIMALIZED NUMBERS INDICATE METRES

**PROPERTY LIMITS DELINEATION**

DELINEATION OF PROPERTY LIMITS AS SHOWN ON THIS DWG DOES NOT REPRESENT A "LEGAL SURVEY". KGS GROUP MAKES NO REPRESENTATION OR WARRANTY AS TO THE ACCURACY OF PROPERTY LIMITS DELINEATED ON THIS DWG, NOR ON THE DIMENSIONAL ACCURACY OF DWG FEATURES RELATIVE TO THOSE PROPERTY LIMITS.

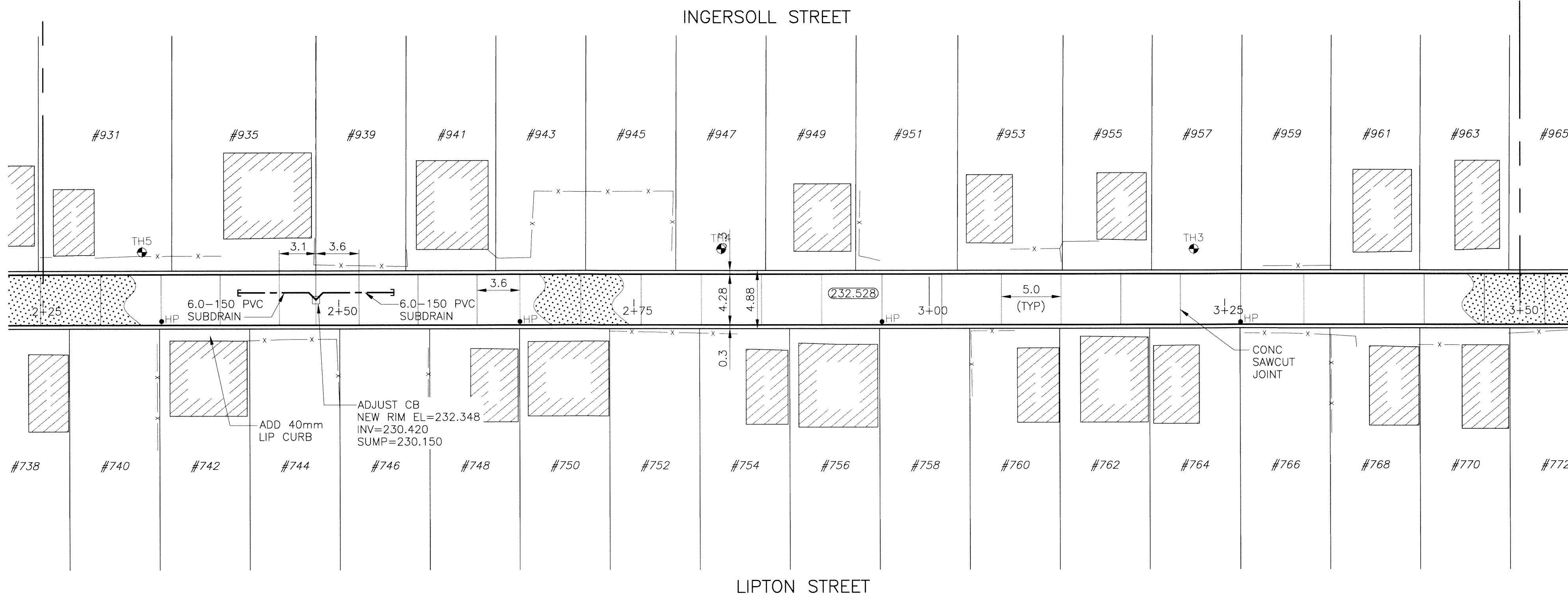

**ALLEY PAVEMENT PLAN**

SCALE: 1:250 HOR

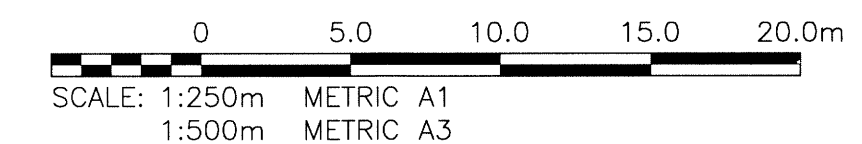
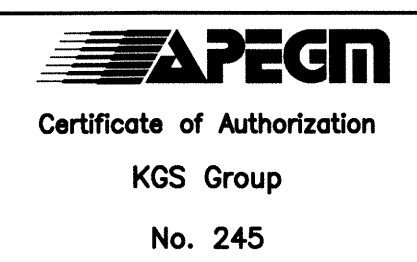

300 LBS	LAND DRAINAGE SEWER	300 LBS							
250 WWS	WASTE WATER SEWER	250 WWS	TEST HOLE						
	GAS		GUY WIRE						
	HYDRO		LIGHT STANDARD						
	M.T.S.		BACK OF CURB						
150 WM	WATERMAIN	150 WM	CONCRETE						
	HYDRANT		ASPHALT						
	VALVE		SIDEWALK						
	MANHOLE		PROPERTY LINE						
	CATCH BASIN		SURVEY BAR						
	CURB INLET		GEODETIC BENCHMARK						
	POLES		ELEVATION	231.334	(32.231)	TTTTT			
EXISTING	LEGEND-PLAN	PROPOSED	EXISTING	LEGEND-PLAN	PROPOSED	EXISTING	LEGEND-PROFILE	PROPOSED	

**LOCATION APPROVED UNDERGROUND STRUCTURES**

SUPV. U/G STRUCTURES COMMITTEE DATE

NOTE: LOCATION OF UNDERGROUND STRUCTURES AS SHOWN ARE BASED ON THE BEST INFORMATION AVAILABLE BUT NO GUARANTEE IS GIVEN THAT ALL EXISTING UTILITIES ARE SHOWN OR THAT THE GIVEN LOCATIONS ARE EXACT. CONFIRMATION OF EXISTENCE AND EXACT LOCATION OF ALL SERVICES MUST BE OBTAINED FROM THE INDIVIDUAL UTILITIES BEFORE PROCEEDING WITH CONSTRUCTION.

B.M. 36-014	Bolt in 7.3m conc. pile, 2.2m S. of S.L. of S.L. of Wellington Ave. & 2.4m W. of E.L. of Lipton St.	ELEV. 232.151			
NO.	REVISIONS	DATE	BY	DATE	BY
0	ISSUED FOR TENDER	14/07/25	CK		
				14/05/02	

<b>KGS GROUP CONSULTING ENGINEERS</b>	
DESIGNED BY: RBO	CHECKED BY: [Signature]
DRAWN BY: GEL/DMW	APPROVED BY: [Signature]
HOR. SCALE: 1:250	RELEASED FOR CONSTRUCTION: [Date]
VERTICAL: 1:50	DATE: 14/05/02

ENGINEER'S SEAL

PROVINCE OF MANITOBA

M.C. ROWBOTHAM

Member 22679

JULY 25, 2014

CONSULTANT DRAWING NO. 13-0107-032\_C09

**THE CITY OF WINNIPEG PUBLIC WORKS DEPARTMENT TRANSPORTATION ENGINEERING DIVISION**

PROJECT TITLE: 2014 ALLEY RENEWAL PROGRAM CONTRACT 2

INGERSOLL ST/LIPTON ST SARGENT AVE TO WELLINGTON AVE STA 2+25 TO STA 3+50

SHEET 09 OF 17

COMPUTER FILE NAME: 13-0107-032\_CALL

CITY DRAWING NUMBER: 0009

P:\Projects\2013\13-0107-032\Doc Control\Tobiasued\DWG\448-2014\_Drawing-0009-Rev 0.dwg - Tab: C09 Plotted By: DWeber 07/25/2014 [Fri: 10:10am] PLOT 1:1 A-1