

### ALLEY PAVEMENT PROFILE

SCALE: 1:250 HOR  
1:10 VER

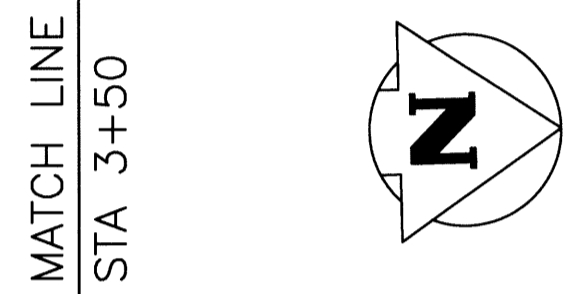

INGERSOLL STREET

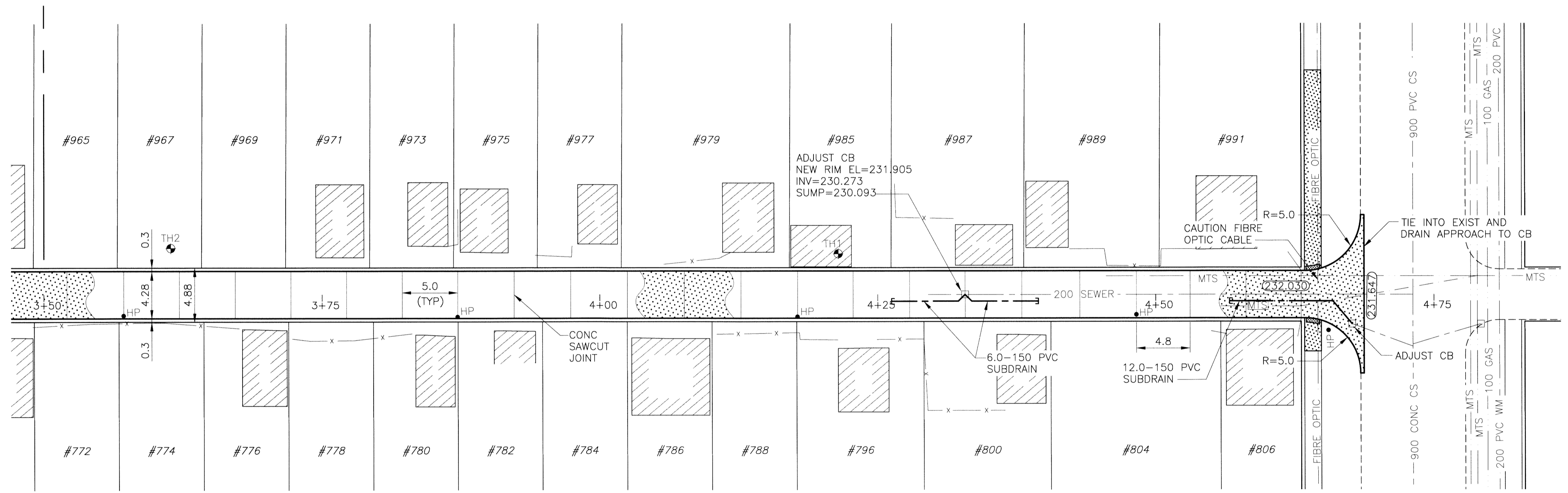

LIPTON STREET

### ALLEY PAVEMENT PLAN

SCALE: 1:250 HOR

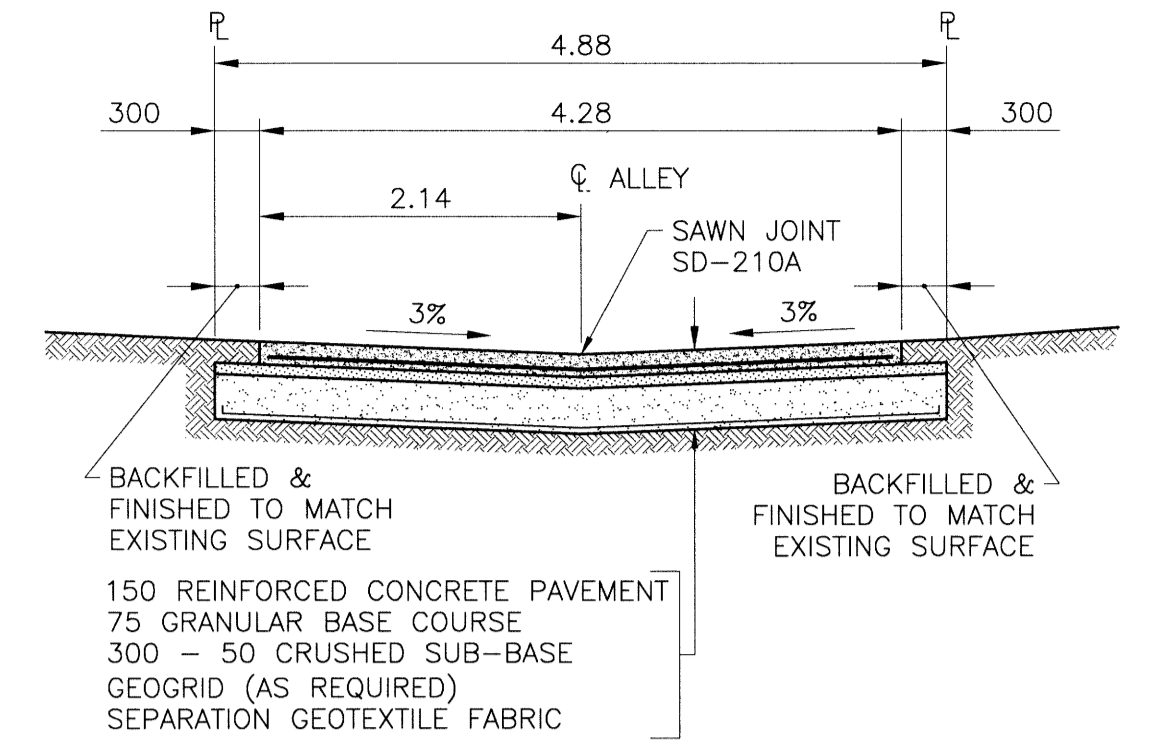

### TYPICAL CROSS SECTION

SCALE: 1:50

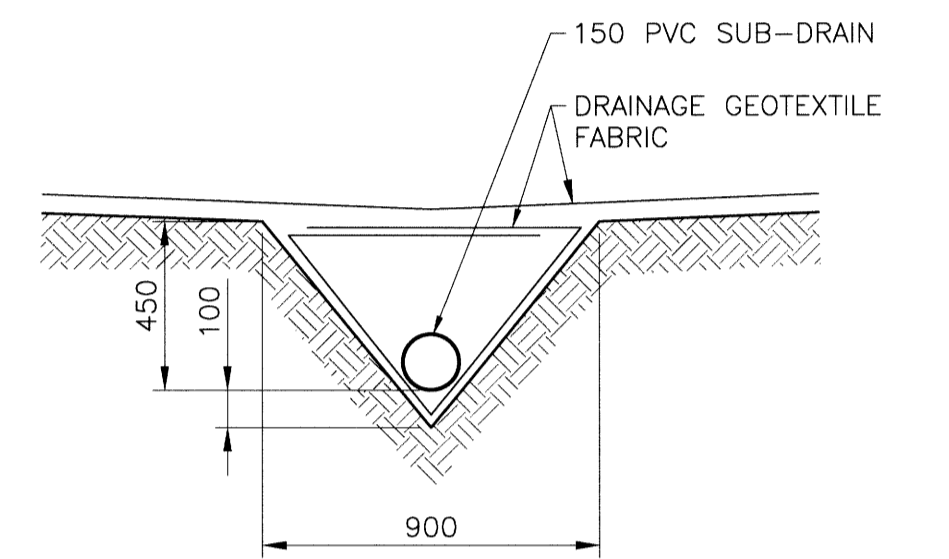

### SUB-DRAIN DETAIL

SCALE: 1:20

#### NOTES:

- STATION CHAINAGE IS BASED ON CENTERLINE OF ALLEY RIGHT OF WAY.
- ADJUST MH AND CB RIMS TO NEW GRADES.
- PLUG SUB-DRAINS AT TERMINAL ENDS.
- REGRADE EXISTING PRIVATE SIDEWALKS AS REQUIRED.
- INSTALLATION OF LIP CURBS AND THEIR EXTENTS TO BE DETERMINED BY THE CONTRACT ADMINISTRATOR.
- LIGHT STANDARDS, HYDRO POLES AND ANCHORS MAY REQUIRE TEMPORARY SUPPORT/REMOVAL OR REPLACEMENT AT THE CONTRACTOR'S EXPENSE.
- ISOLATE ALL POLES, BASES AND PILES WITHIN ALLEY RIGHT OF WAY (SD-228C)
- AVOID DAMAGE TO EXISTING TREES WITHIN THE LIMITS OF CONSTRUCTION
- CITY OF WINNIPEG SURVEY MONUMENTS EXIST ON THIS SITE. CONTRACTOR TO CONTACT THE CITY OF WINNIPEG GEOMATICS BRANCH 5 WORKING DAYS IN ADVANCE OF CONSTRUCTION TO COORDINATE MONUMENT PROTECTION SERVICES (204-918-1360)

### WARNING

NOTIFY THE GAS COMPANY OF THE PROPOSED LOCATION OF EXCAVATION. TAKE PRECAUTION TO AVOID DAMAGE TO GAS COMPANY INSTALLATIONS. SEE PROVINCIAL REGULATION 210/72 FOR DETAILS.

### METRIC

WHOLE NUMBERS INDICATE MILLIMETRES  
DECIMALIZED NUMBERS INDICATE METRES

### PROPERTY LIMITS DELINEATION

DELINEATION OF PROPERTY LIMITS AS SHOWN ON THIS DWG DOES NOT REPRESENT A "LEGAL SURVEY". KGS GROUP MAKES NO REPRESENTATION OR WARRANTY AS TO THE ACCURACY OF PROPERTY LIMITS DELINEATED ON THIS DWG, NOR ON THE DIMENSIONAL ACCURACY OF DWG FEATURES RELATIVE TO THOSE PROPERTY LIMITS.

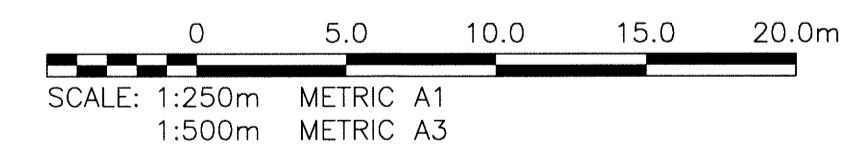

Certificate of Authorization  
KGS Group  
No. 245

300_LDS	LAND DRAINAGE SEWER	300_LDS	TEST HOLE
250_WWS	WASTE WATER SEWER	250_WWS	GUY WIRE
	GAS		LIGHT STANDARD
	HYDRO		BACK OF CURB
	M.T.S.		CONCRETE
150_WM	WATERMAIN	150_WM	ASPHALT
	HYDRANT		SIDEWALK
	VALVE		PROPERTY LINE
	MANHOLE		SURVEY BAR
	CATCH BASIN		GEODETIC BENCHMARK
	CURB INLET		ELEVATION
	POLES		
EXISTING	LEGEND-PLAN	PROPOSED	LEGEND-PLAN

**LOCATION APPROVED UNDERGROUND STRUCTURES**

SUPV. U/G STRUCTURES COMMITTEE DATE

NOTE: LOCATION OF UNDERGROUND STRUCTURES AS SHOWN ARE BASED ON THE BEST INFORMATION AVAILABLE BUT NO GUARANTEE IS GIVEN THAT ALL EXISTING UTILITIES ARE SHOWN OR THAT THE GIVEN LOCATIONS ARE EXACT. CONFIRMATION OF EXISTENCE AND EXACT LOCATION OF ALL SERVICES MUST BE OBTAINED FROM THE INDIVIDUAL UTILITIES BEFORE PROCEEDING WITH CONSTRUCTION.

B.M. 36-014 Bolt in 7.3m conc. pile, 2.2m S. of S.L. of S.L. of Wellington Ave. & 2.4m W. of E.L. of Lipton St.

DESIGNED BY: RBO  
CHECKED BY: [Signature]  
DRAWN BY: GEL/DMW  
APPROVED BY: [Signature]

HOR. SCALE: 1:250  
VERTICAL: 1:50

ISSUED FOR TENDER: 14/07/25  
NO. REVISIONS: 1 DATE: 14/05/02

**KGS GROUP CONSULTING ENGINEERS**

ENGINEER'S SEAL: M.G. ROWBOTHAM, Member 22879, July 23, 2014

CONSULTANT DRAWING NO. 13-0107-032\_C10

**THE CITY OF WINNIPEG PUBLIC WORKS DEPARTMENT TRANSPORTATION ENGINEERING DIVISION**

PROJECT TITLE: 2014 ALLEY RENEWAL PROGRAM CONTRACT 2  
INGERSOLL ST/LIPTON ST  
SARGENT AVE TO WELLINGTON AVE  
STA 3+50 TO WELLINGTON AVE

SHEET OF 10 17  
COMPUTER FILE NAME: 13-0107-032\_CALL  
CITY DRAWING NUMBER: 0010