

ALLEY PAVEMENT PROFILE

SCALE: 1:250 HOR
1:10 VER

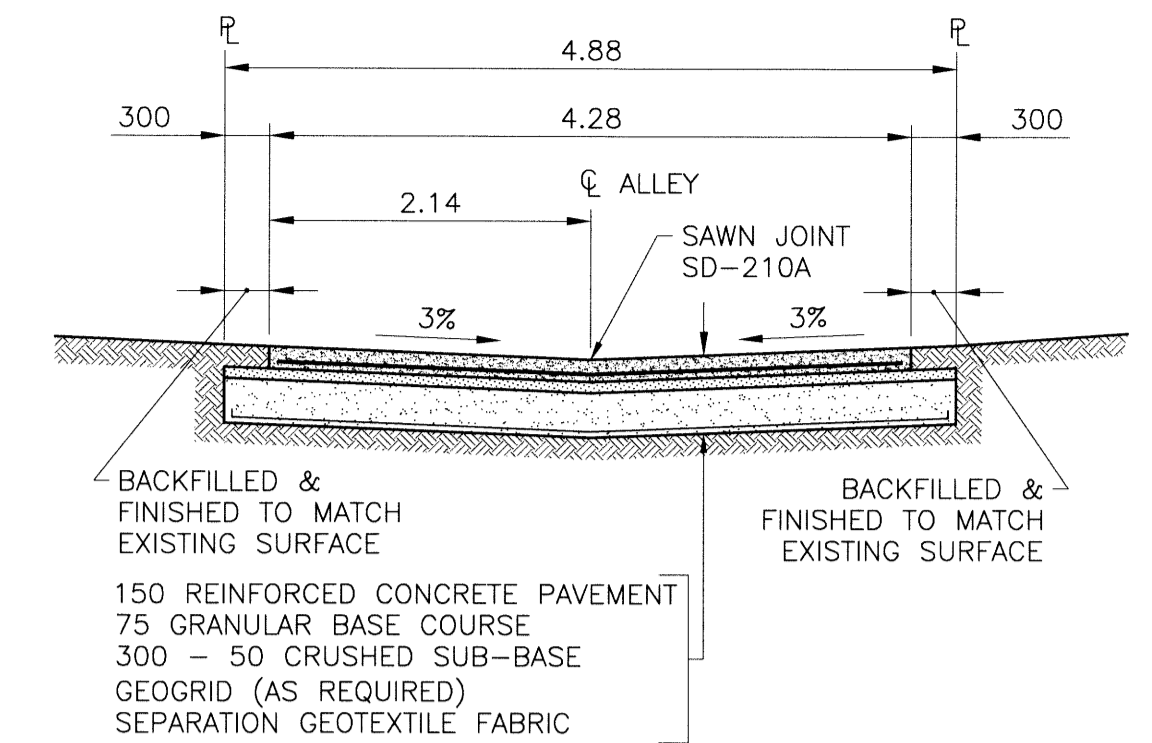

TYPICAL CROSS SECTION

SCALE: 1:50

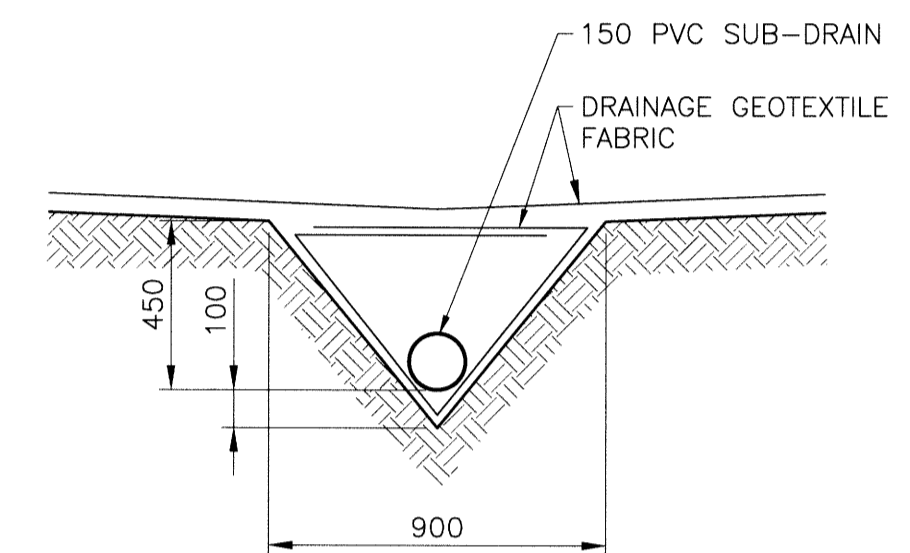

SUB-DRAIN DETAIL

SCALE: 1:20

NOTES:

1. STATION CHAINAGE IS BASED ON CENTERLINE OF ALLEY RIGHT OF WAY.
2. ADJUST MH AND CB RIMS TO NEW GRADES.
3. PLUG SUB-DRAINS AT TERMINAL ENDS.
4. REGRADE EXISTING PRIVATE SIDEWALKS AS REQUIRED.
5. INSTALLATION OF LIP CURBS AND THEIR EXTENTS TO BE DETERMINED BY THE CONTRACT ADMINISTRATOR.
6. LIGHT STANDARDS, HYDRO POLES AND ANCHORS MAY REQUIRE TEMPORARY SUPPORT/REMOVAL OR REPLACEMENT AT THE CONTRACTOR'S EXPENSE.
7. ISOLATE ALL POLES, BASES AND PILES WITHIN ALLEY RIGHT OF WAY (SD-228C)
8. AVOID DAMAGE TO EXISTING TREES WITHIN THE LIMITS OF CONSTRUCTION
9. CITY OF WINNIPEG SURVEY MONUMENTS EXIST ON THIS SITE. CONTRACTOR TO CONTACT THE CITY OF WINNIPEG GEOMATICS BRANCH 5 WORKING DAYS IN ADVANCE OF CONSTRUCTION TO COORDINATE MONUMENT PROTECTION SERVICES (204-918-1360)

WARNING

NOTIFY THE GAS COMPANY OF THE PROPOSED LOCATION OF EXCAVATION. TAKE PRECAUTION TO AVOID DAMAGE TO GAS COMPANY INSTALLATIONS. SEE PROVINCIAL REGULATION 210/72 FOR DETAILS.

METRIC

WHOLE NUMBERS INDICATE MILLIMETRES
DECIMALIZED NUMBERS INDICATE METRES

PROPERTY LIMITS DELINEATION

DELINEATION OF PROPERTY LIMITS AS SHOWN ON THIS DWG DOES NOT REPRESENT A "LEGAL SURVEY". KGS GROUP MAKES NO REPRESENTATION OR WARRANTY AS TO THE ACCURACY OF PROPERTY LIMITS DELINEATED ON THIS DWG, NOR ON THE DIMENSIONAL ACCURACY OF DWG FEATURES RELATIVE TO THOSE PROPERTY LIMITS.

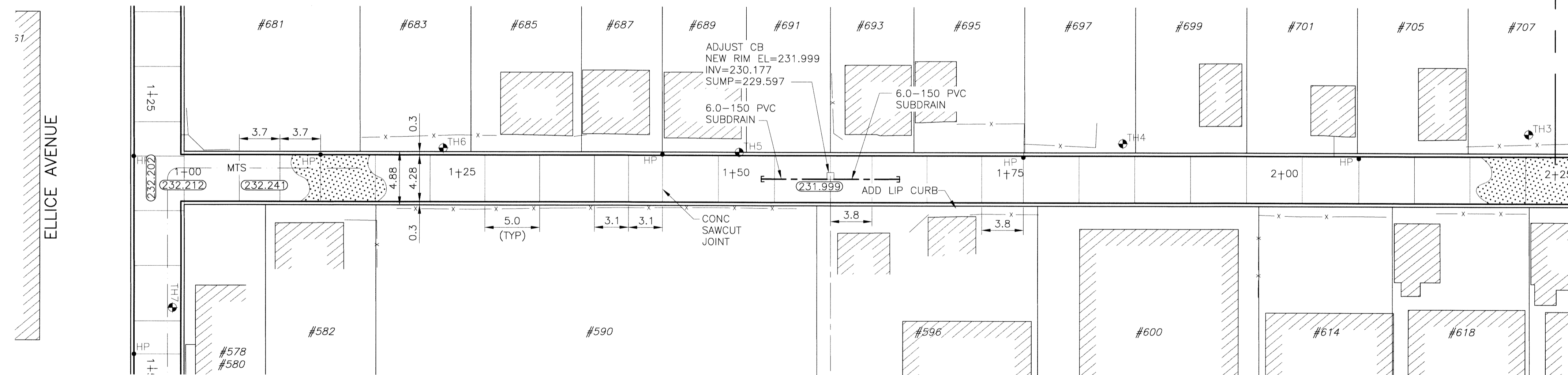
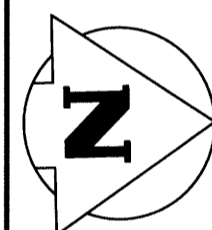
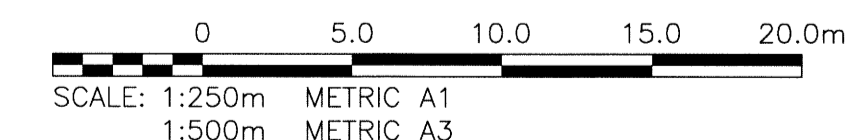

ALLEY PAVEMENT PLAN

SCALE: 1:250 HOR

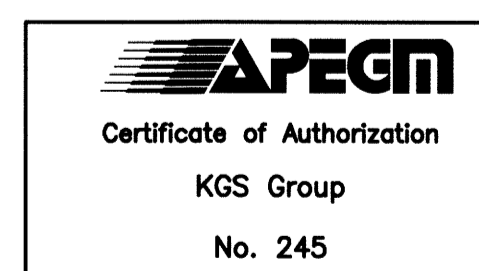

300 LBS	LAND DRAINAGE SEWER	300 LBS							
250 WWS	WASTE WATER SEWER	250 WWS	TEST HOLE						
	GAS		GUY WIRE						
	HYDRO		LIGHT STANDARD						
	M.T.S.		BACK OF CURB						
150 WM	WATERMAIN	150 WM	CONCRETE						
	HYDRANT		ASPHALT						
	VALVE		SIDEWALK						
	MANHOLE		PROPERTY LINE						
	CATCH BASIN		SURVEY BAR						
	CURB INLET		GEODETIC BENCHMARK						
	POLES		ELEVATION	231.334					
EXISTING	LEGEND-PLAN	PROPOSED	EXISTING	LEGEND-PLAN	PROPOSED	EXISTING	LEGEND-PROFILE	PROPOSED	

LOCATION APPROVED UNDERGROUND STRUCTURES

SUPV. U/G STRUCTURES COMMITTEE DATE

NOTE:
LOCATION OF UNDERGROUND STRUCTURES AS SHOWN ARE BASED ON THE BEST INFORMATION AVAILABLE BUT NO GUARANTEE IS GIVEN THAT ALL EXISTING UTILITIES ARE SHOWN OR THAT THE GIVEN LOCATIONS ARE EXACT. CONFIRMATION OF EXISTENCE AND EXACT LOCATION OF ALL SERVICES MUST BE OBTAINED FROM THE INDIVIDUAL UTILITIES BEFORE PROCEEDING WITH CONSTRUCTION.

B.M. 36-062 ELEV. 233.238	N.W. Cor. Sargent Ave. & Burnell St., Tbt. in S. Tyndall stone footing of No. 845 Sargent Ave. (firehall No. 5), 0.5m W. & 0.55m below brick of S.E. Cor. of bldg.		
0	ISSUED FOR TENDER	14/07/25	CR
NO.	REVISIONS	DATE	BY

KGS GROUP CONSULTING ENGINEERS	
DESIGNED BY: RBO	CHECKED BY: [Signature]
DRAWN BY: GEL/DMW	APPROVED BY: [Signature]
HOR. SCALE: 1:250	RELEASED FOR CONSTRUCTION:
VERTICAL: 1:50	DATE: 14/05/02

ENGINEER'S SEAL

CONSULTANT DRAWING NO. 13-0107-032_C12

THE CITY OF WINNIPEG
PUBLIC WORKS DEPARTMENT
TRANSPORTATION ENGINEERING DIVISION

PROJECT TITLE: 2014 ALLEY RENEWAL PROGRAM CONTRACT 2
BANNING ST/BURNELL ST
ELLICE AVE TO SARGENT AVE
ELLICE AVE TO STA 2+25

SHEET 12 OF 17
COMPUTER FILE NAME: 13-0107-032_CALL
CITY DRAWING NUMBER: 0012

P:\Projects\2013\13-0107-032\Doc\Control\Tobiasseu\DWG\748-2014_Drawing_0012-Rev 0.dwg - Tab: C12 Plotted By: DWeber 07/25/2014 [Fri 10:14am] PLOT 1: A-1