

**ALLEY PAVEMENT PROFILE**

SCALE: 1:250 HOR  
1:10 VER

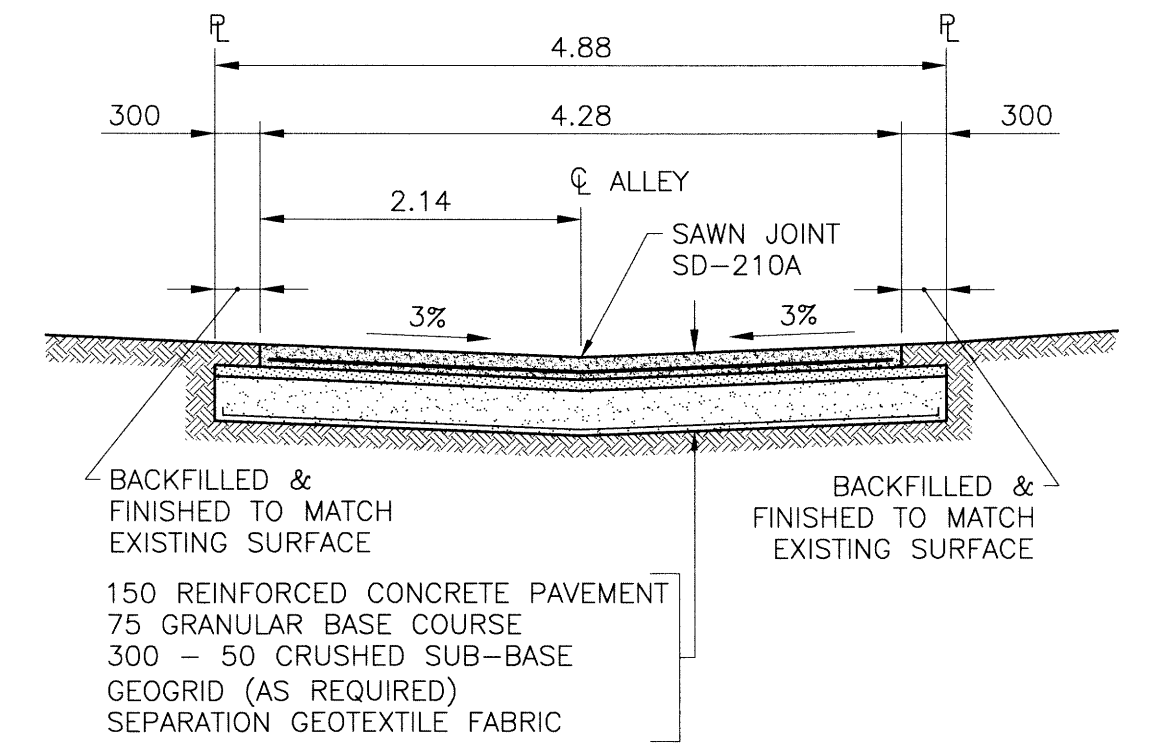

**TYPICAL CROSS SECTION**

SCALE: 1:50

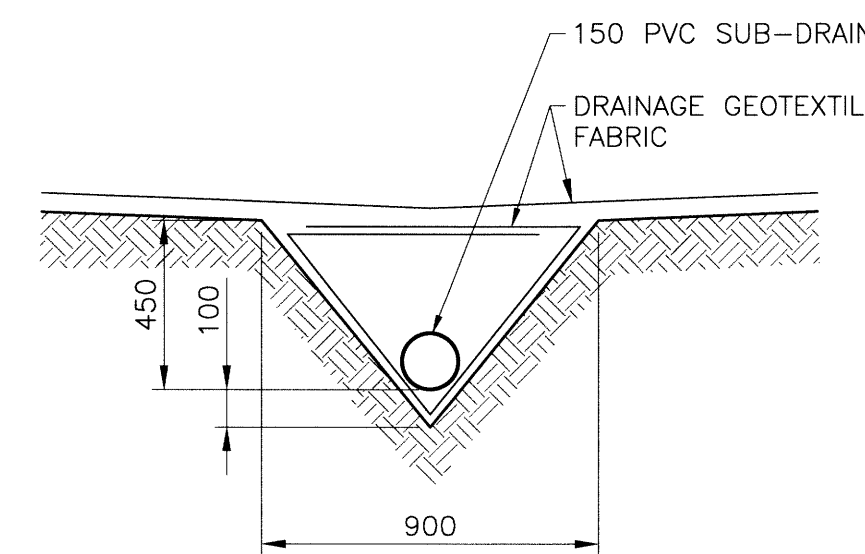

**SUB-DRAIN DETAIL**

SCALE: 1:20

**NOTES:**

1. STATION CHAINAGE IS BASED ON CENTERLINE OF ALLEY RIGHT OF WAY.
2. ADJUST MH AND CB RIMS TO NEW GRADES.
3. PLUG SUB-DRAINS AT TERMINAL ENDS.
4. REGRADE EXISTING PRIVATE SIDEWALKS AS REQUIRED.
5. INSTALLATION OF LIP CURBS AND THEIR EXTENTS TO BE DETERMINED BY THE CONTRACT ADMINISTRATOR.
6. LIGHT STANDARDS, HYDRO POLES AND ANCHORS MAY REQUIRE TEMPORARY SUPPORT/REMOVAL OR REPLACEMENT AT THE CONTRACTOR'S EXPENSE.
7. ISOLATE ALL POLES, BASES AND PILES WITHIN ALLEY RIGHT OF WAY (SD-228C)
8. AVOID DAMAGE TO EXISTING TREES WITHIN THE LIMITS OF CONSTRUCTION
9. CITY OF WINNIPEG SURVEY MONUMENTS EXIST ON THIS SITE. CONTRACTOR TO CONTACT THE CITY OF WINNIPEG GEOMATICS BRANCH 5 WORKING DAYS IN ADVANCE OF CONSTRUCTION TO COORDINATE MONUMENT PROTECTION SERVICES (204-918-1360)

**WARNING**

NOTIFY THE GAS COMPANY OF THE PROPOSED LOCATION OF EXCAVATION. TAKE PRECAUTION TO AVOID DAMAGE TO GAS COMPANY INSTALLATIONS. SEE DETAILED REGULATION 210/72 FOR DETAILS.

**METRIC**

WHOLE NUMBERS INDICATE MILLIMETRES  
DECIMALIZED NUMBERS INDICATE METRES

**PROPERTY LIMITS DELINEATION**

DELINEATION OF PROPERTY LIMITS AS SHOWN ON THIS DWG DOES NOT REPRESENT A "LEGAL SURVEY". KGS GROUP MAKES NO REPRESENTATION OR WARRANTY AS TO THE ACCURACY OF PROPERTY LIMITS DELINEATED ON THIS DWG, NOR ON THE DIMENSIONAL ACCURACY OF DWG FEATURES RELATIVE TO THOSE PROPERTY LIMITS.

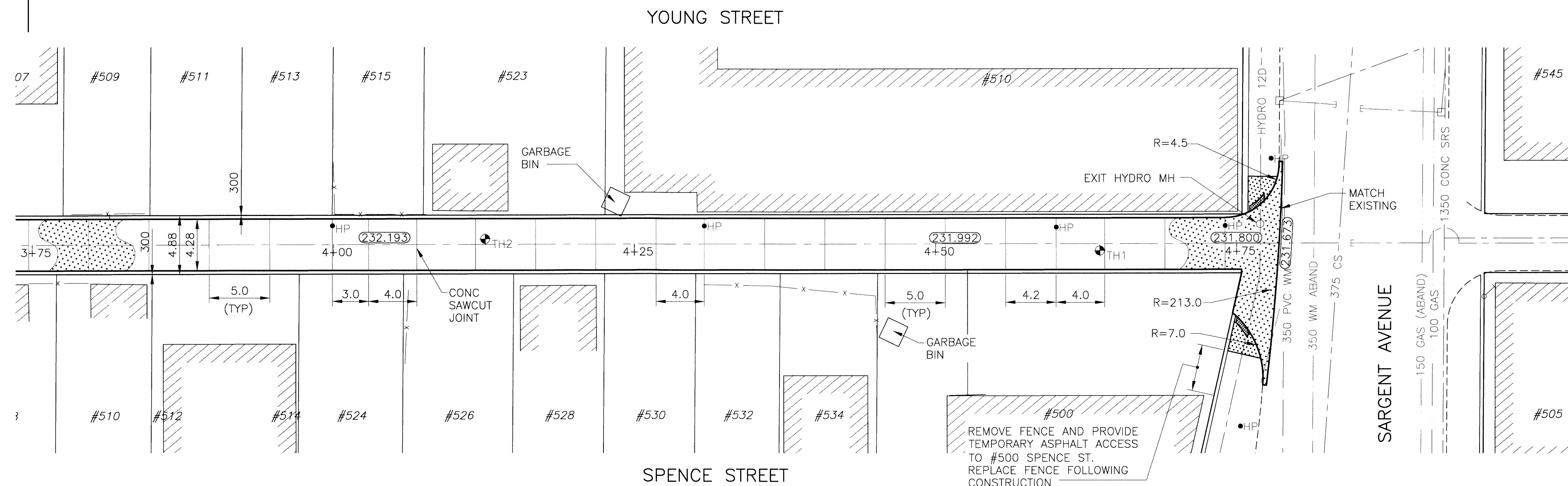
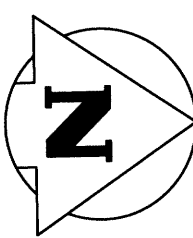

**ALLEY PAVEMENT PLAN**

SCALE: 1:250 HOR



Certificate of Authorization

KGS Group

No. 245

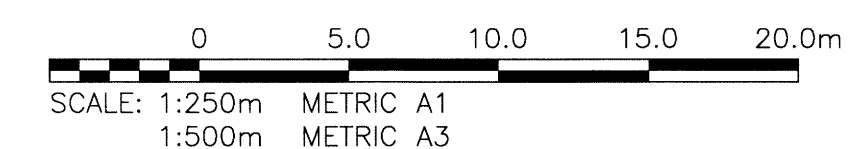

EXISTING	LEGEND-PLAN	PROPOSED	EXISTING	LEGEND-PLAN	PROPOSED
300 LBS	LAND DRAINAGE SEWER	300 LBS	TEST HOLE		
250 WWS	WASTE WATER SEWER	250 WWS	GUY WIRE		
	GAS		LIGHT STANDARD		
	HYDRO		BACK OF CURB		
	M.T.S.		CONCRETE		
150 WM	WATERMAIN	150 WM	ASPHALT		
	HYDRANT		SIDEWALK		
	VALVE		PROPERTY LINE		
	MANHOLE		SURVEY BAR		
	CATCH BASIN		GEODETIC BENCHMARK		
	CURB INLET		ELEVATION	(32.231)	
	POLES				

**LOCATION APPROVED UNDERGROUND STRUCTURES**

SUPV. U/G STRUCTURES DATE COMMITTEE

NOTE: LOCATION OF UNDERGROUND STRUCTURES AS SHOWN ARE BASED ON THE BEST INFORMATION AVAILABLE, BUT NO GUARANTEE IS GIVEN THAT ALL EXISTING UTILITIES ARE SHOWN OR THAT THE GIVEN LOCATIONS ARE EXACT. CONFIRMATION OF EXISTENCE AND EXACT LOCATION OF ALL SERVICES MUST BE OBTAINED FROM THE INDIVIDUAL UTILITIES BEFORE PROCEEDING WITH CONSTRUCTION.

B.M.	37-020	S.E. Cor. Sargent Ave. & Spence St. Tolt. in N. Conc. foundation No. 486 Sargent Ave. 0.5m E. & 0.1m below brick of N.W. Cor. of Bldg.
ELEV.	232.298	
NO.	REVISIONS	DATE
0	ISSUED FOR TENDER	14/07/25

DESIGNED BY	RBO	CHECKED BY	BAM
DRAWN BY	GEL/DMW	APPROVED BY	PH
HOR. SCALE:	1:250	RELEASED FOR CONSTRUCTION:	
VERTICAL:	1:50	DATE	14/05/02

ENGINEER'S SEAL

CONSULTANT DRAWING NO.  
**13-0107-032\_C17**

**THE CITY OF WINNIPEG**  
PUBLIC WORKS DEPARTMENT  
TRANSPORTATION ENGINEERING DIVISION

PROJECT TITLE  
**2014 ALLEY RENEWAL PROGRAM CONTRACT 2**

YOUNG ST/SPENCE ST  
ELLICE AVE TO SARGENT AVE  
STA 3+75 TO SARGENT AVE

SHEET OF  
**17** OF **17**

COMPUTER FILE NAME  
13-0107-032\_CALL

CITY DRAWING NUMBER  
**0017**