

ALLEY PAVEMENT PROFILE
SCALE: 1:250 HOR
1:10 VER

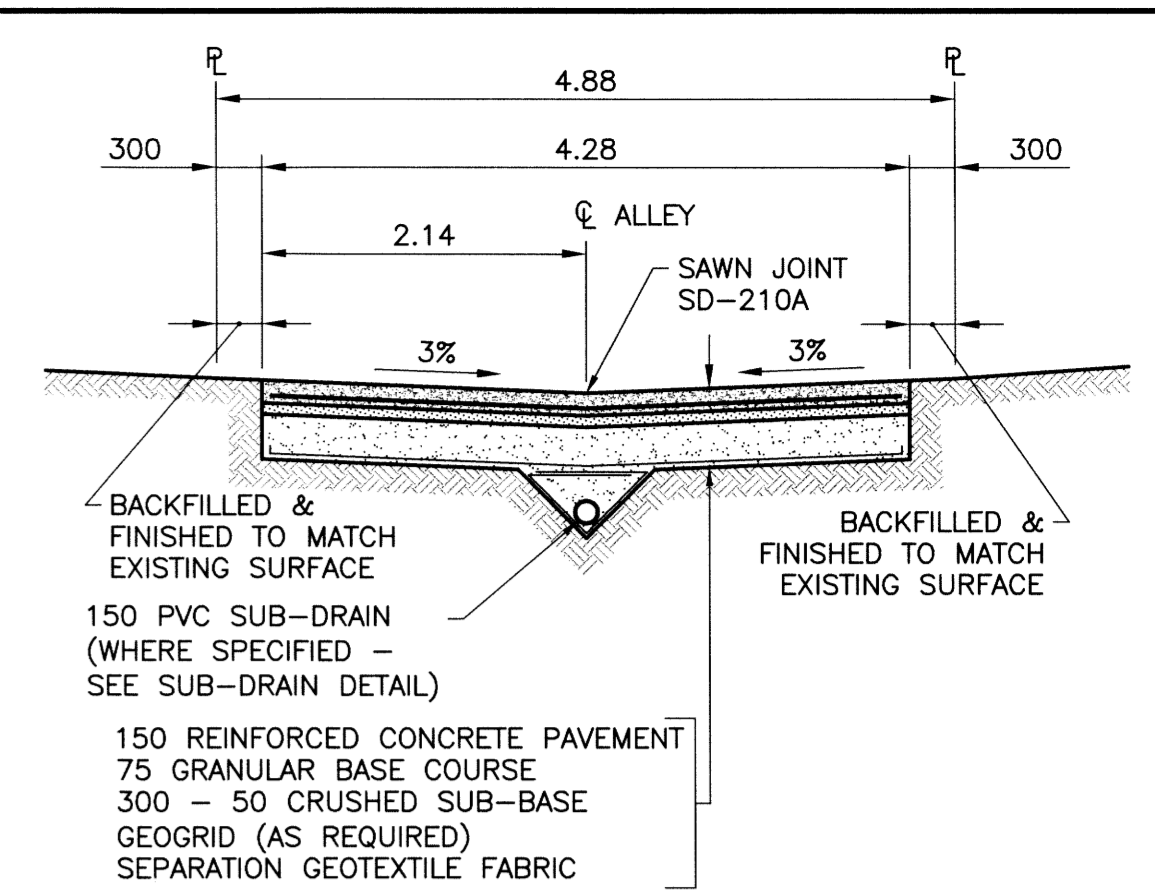

TYPICAL CROSS SECTION
SCALE: 1:50

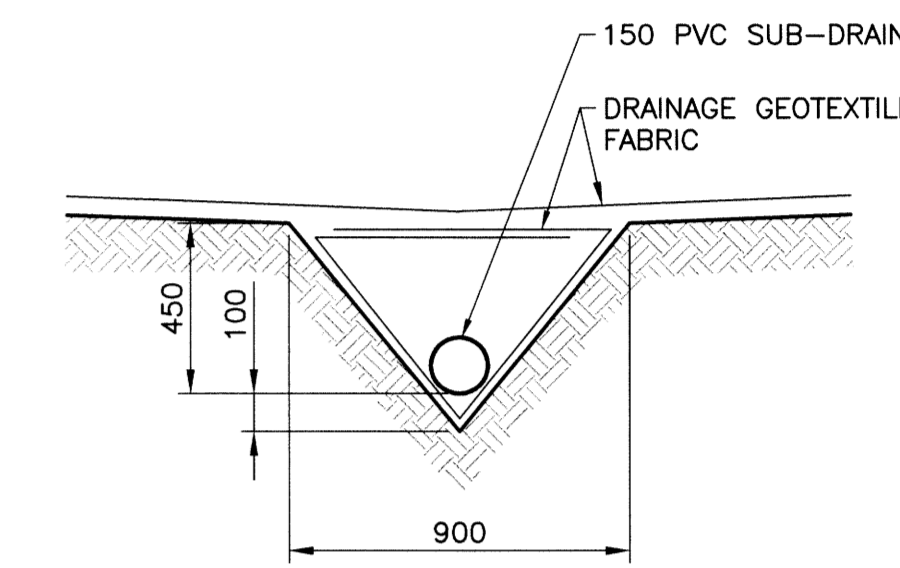

SUB-DRAIN DETAIL
SCALE: 1:20

NOTES

1. STATION CHAINAGE IS BASED ON CENTERLINE OF ALLEY RIGHT OF WAY.
2. ADJUST MH AND CB RIMS TO NEW GRADES.
3. PLUG SUB-DRAINS AT TERMINAL ENDS.
4. REGRADE EXISTING PRIVATE SIDEWALKS AS REQUIRED.
5. INSTALLATION OF LIP CURBS AND THEIR EXTENTS TO BE DETERMINED BY THE CONTRACT ADMINISTRATOR.
6. LIGHT STANDARDS, HYDRO POLES AND ANCHORS MAY REQUIRE TEMPORARY SUPPORT/REMOVAL OR REPLACEMENT AT THE CONTRACTOR'S EXPENSE.
7. ISOLATE ALL POLES, BASES AND PILES WITHIN ALLEY RIGHT OF WAY (SD-228C).
8. AVOID DAMAGE TO EXISTING TREES WITHIN THE LIMITS OF CONSTRUCTION.
9. CITY OF WINNIPEG SURVEY MONUMENTS EXIST ON THIS SITE. CONTRACTOR TO CONTACT THE CITY OF WINNIPEG GEOMATICS BRANCH 5 WORKING DAYS IN ADVANCE OF CONSTRUCTION TO COORDINATE MONUMENT PROTECTION SERVICES (204-918-1360).
10. ALLEY TO BE CONSTRUCTED IN PHASES AS SHOWN.
11. ALL EXCAVATIONS WITHIN 1.0m OF ANY NATURAL GAS MAIN MUST BE COMPLETED BY HAND OR HYDRO EXCAVATION.

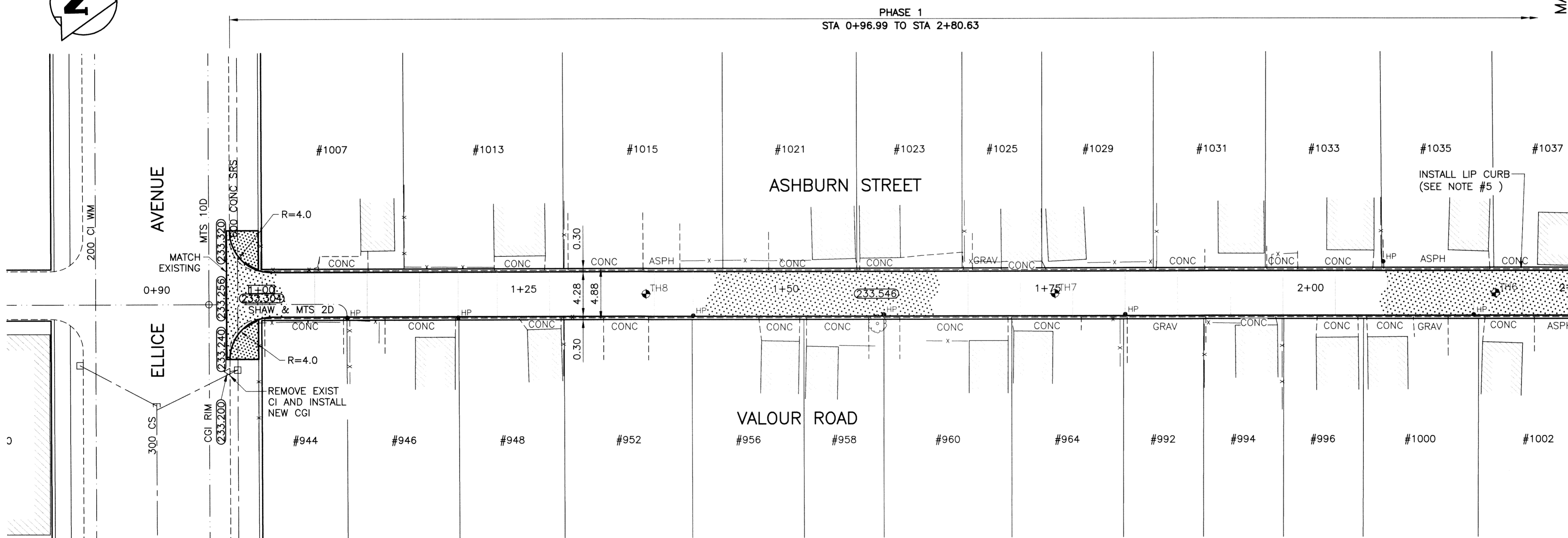
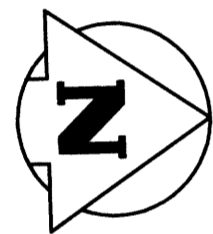

ALLEY PAVEMENT PLAN
SCALE: 1:250 HOR

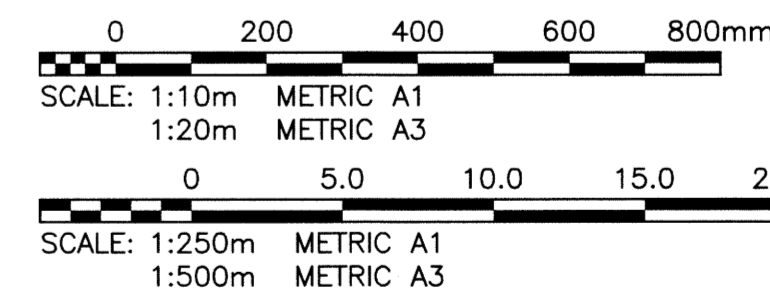

METRIC
WHOLE NUMBERS INDICATE MILLIMETRES
DECIMALIZED NUMBERS INDICATE METRES

PROPERTY LIMITS DELINEATION

WARNING

NOTIFY THE GAS COMPANY OF THE PROPOSED LOCATION OF EXCAVATION. TAKE PRECAUTION TO AVOID DAMAGE TO GAS COMPANY INSTALLATIONS. SEE PROVINCIAL REGULATION 210/72 FOR DETAILS.

DELINEATION OF PROPERTY LIMITS AS SHOWN ON THIS DWG DOES NOT REPRESENT A "LEGAL SURVEY". KGS GROUP MAKES NO REPRESENTATION OR WARRANTY AS TO THE ACCURACY OF PROPERTY LIMITS DELINEATED ON THIS DWG, NOR ON THE DIMENSIONAL ACCURACY OF DWG FEATURES RELATIVE TO THOSE PROPERTY LIMITS.

APEGN
Certificate of Authorization
KGS Group
No. 245

ENGINEER'S SEAL
R.B. OFFMAN
Member
24701

THE CITY OF WINNIPEG
PUBLIC WORKS DEPARTMENT
TRANSPORTATION ENGINEERING DIVISION

PROJECT TITLE
2015 ALLEY RENEWAL PROGRAM
CONTRACT 1
ASHBURN ST/VALOUR RD
ELLICE AVE TO SARGENT AVE
ELLICE AVE TO STA 2+25

SHEET OF
01 OF **15**

COMPUTER FILE NAME
14-0107-031_Contract 1

CITY DRAWING NUMBER
C101

300 LBS	LAND DRAINAGE SEWER	300 LBS		TEST HOLE			
250 WWS	WASTE WATER SEWER	250 WWS		GUY WIRE			
	GAS			LIGHT STANDARD			
	HYDRO			BACK OF CURB			
	M.T.S.			CONCRETE			
150 WM	WATERMAIN	150 WM		ASPHALT			
	HYDRANT			SIDEWALK			
	VALVE			PROPERTY LINE			
	MANHOLE			SURVEY BAR			
	CATCH BASIN			GEODETIC BENCHMARK			
	CURB INLET			ELEVATION			
	POLES						
EXISTING	LEGEND-PLAN	PROPOSED	EXISTING	LEGEND-PLAN	PROPOSED	EXISTING	LEGEND-PROFILE

LOCATION APPROVED UNDERGROUND STRUCTURES

SUPV. U/G STRUCTURES COMMITTEE DATE

NOTE:
LOCATION OF UNDERGROUND STRUCTURES AS SHOWN ARE BASED ON THE BEST INFORMATION AVAILABLE BUT NO GUARANTEE IS GIVEN THAT ALL EXISTING UTILITIES ARE SHOWN OR THAT THE GIVEN LOCATIONS ARE EXACT. CONFIRMATION OF EXISTENCE AND EXACT LOCATION OF ALL SERVICES MUST BE OBTAINED FROM THE INDIVIDUAL UTILITIES BEFORE PROCEEDING WITH CONSTRUCTION.

B.M. 37#25 E. side Wall St. N. of Ellice Ave., Tab. in W. Conc. Foundation No. 919/925 Wall St., 1m N. & 0.1m below scored Conc. block of S.W. Cor. of Bldg. ELEV. 233.121

NO.	REVISIONS	DATE	BY
0	ISSUED FOR TENDER	15/02/23	RBO

KGS GROUP
CONSULTING ENGINEERS

DESIGNED BY	AKW	CHECKED BY	RBO
DRAWN BY	DMW	APPROVED BY	
HOR. SCALE:	1:250	RELEASED FOR CONSTRUCTION:	
VERTICAL:	1:50	DATE	

I:\PMS\14-0107-031\14-0107-031_Contract 1.dwg - Tab: 101 Plotted By: gloewen 02/23/2015 [Mon 9:29am] PLOT 1:1 A-1