

**ALLEY PAVEMENT PROFILE**  
SCALE: 1:250 HOR  
1:10 VER

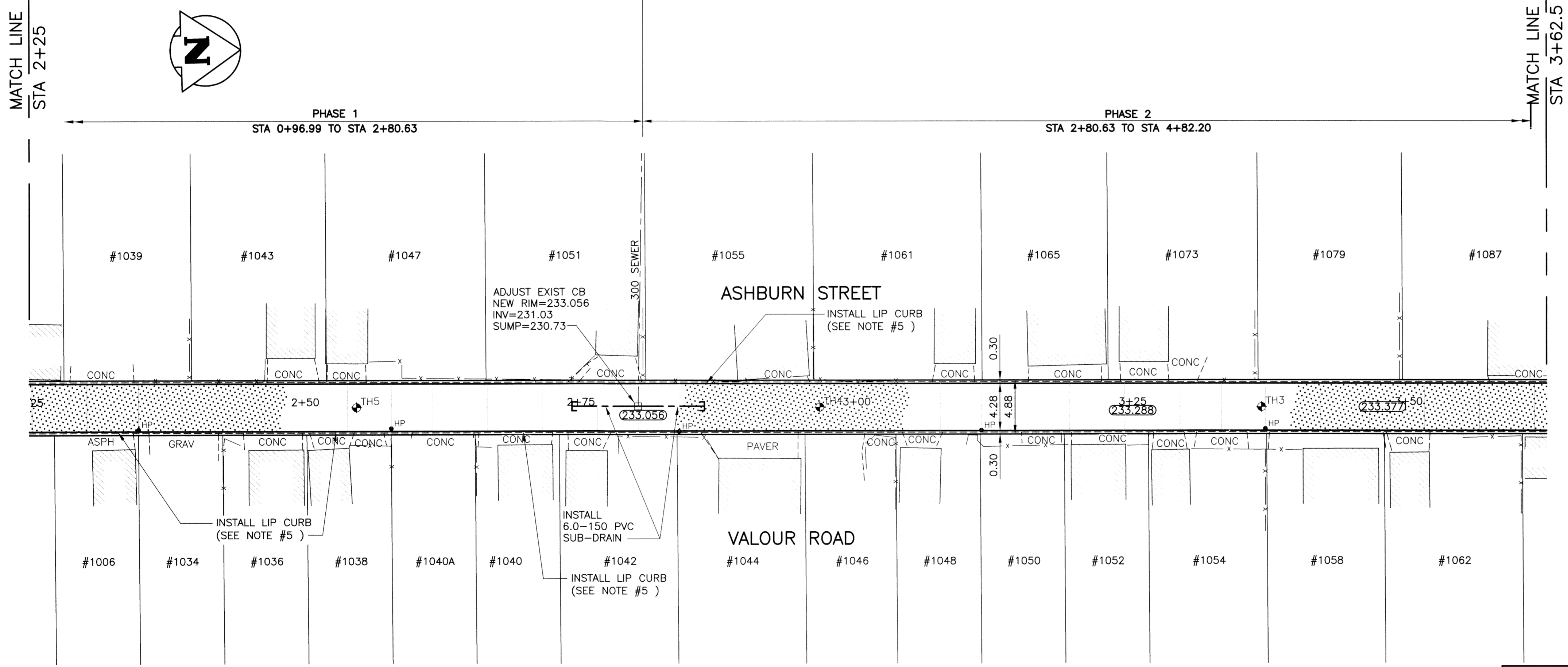

**ALLEY PAVEMENT PLAN**  
SCALE: 1:250 HOR

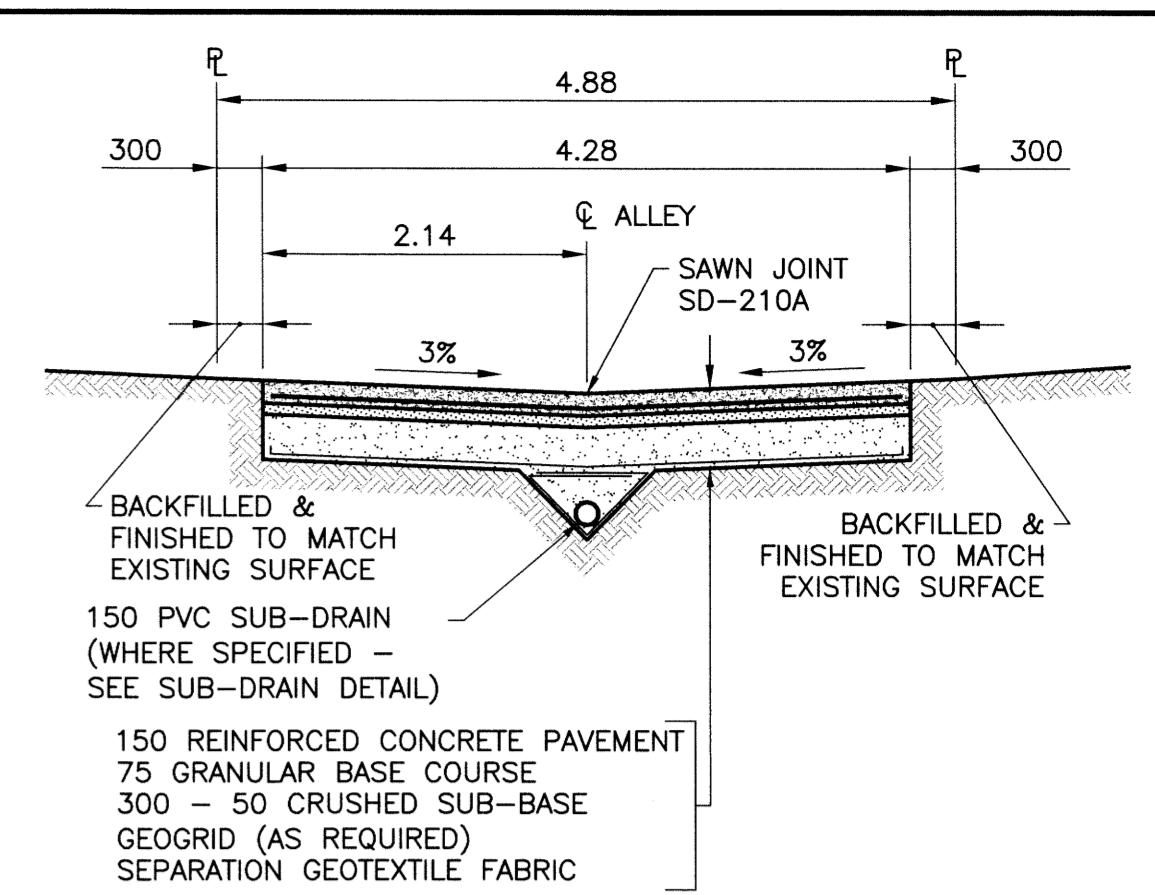

**TYPICAL CROSS SECTION**  
SCALE: 1:50

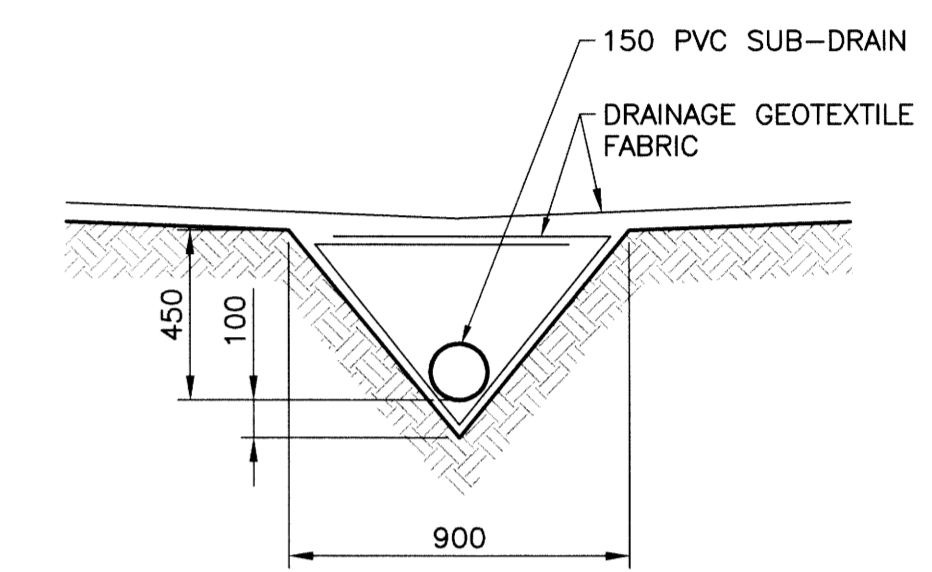

**SUB-DRAIN DETAIL**  
SCALE: 1:20

- NOTES**
1. STATION CHAINAGE IS BASED ON CENTERLINE OF ALLEY RIGHT OF WAY.
  2. ADJUST MH AND CB RIMS TO NEW GRADES.
  3. PLUG SUB-DRAINS AT TERMINAL ENDS.
  4. REGRADE EXISTING PRIVATE SIDEWALKS AS REQUIRED.
  5. INSTALLATION OF LIP CURBS AND THEIR EXTENTS TO BE DETERMINED BY THE CONTRACT ADMINISTRATOR.
  6. LIGHT STANDARDS, HYDRO POLES AND ANCHORS MAY REQUIRE TEMPORARY SUPPORT/REMOVAL OR REPLACEMENT AT THE CONTRACTOR'S EXPENSE.
  7. ISOLATE ALL POLES, BASES AND PILES WITHIN ALLEY RIGHT OF WAY (SD-228C).
  8. AVOID DAMAGE TO EXISTING TREES WITHIN THE LIMITS OF CONSTRUCTION.
  9. CITY OF WINNIPEG SURVEY MONUMENTS EXIST ON THIS SITE. CONTRACTOR TO CONTACT THE CITY OF WINNIPEG GEOMATICS BRANCH 5 WORKING DAYS IN ADVANCE OF CONSTRUCTION TO COORDINATE MONUMENT PROTECTION SERVICES (204-918-1360).
  10. ALLEY TO BE CONSTRUCTED IN PHASES AS SHOWN.
  11. ALL EXCAVATIONS WITHIN 1.0m OF ANY NATURAL GAS MAIN MUST BE COMPLETED BY HAND OR HYDRO EXCAVATION.

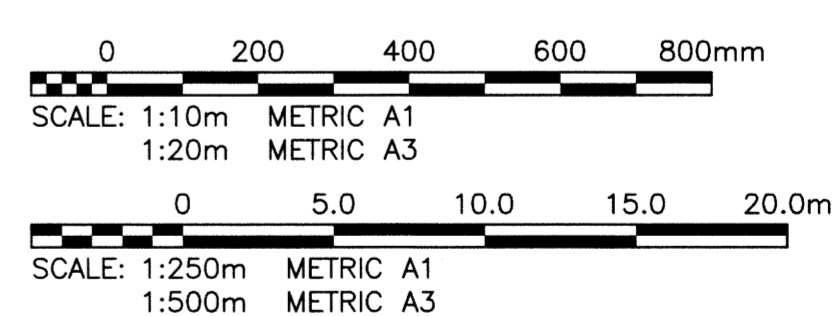

**METRIC**  
WHOLE NUMBERS INDICATE MILLIMETRES  
DECIMALIZED NUMBERS INDICATE METRES

**PROPERTY LIMITS DELINEATION**

**WARNING**  
NOTIFY THE GAS COMPANY OF THE PROPOSED LOCATION OF EXCAVATION. TAKE PRECAUTION TO AVOID DAMAGE TO GAS COMPANY INSTALLATIONS. SEE PROVINCIAL REGULATION 210/72 FOR DETAILS.

DELINEATION OF PROPERTY LIMITS AS SHOWN ON THIS DWG DOES NOT REPRESENT A "LEGAL SURVEY". KGS GROUP MAKES NO REPRESENTATION OR WARRANTY AS TO THE ACCURACY OF PROPERTY LIMITS DELINEATED ON THIS DWG, NOR ON THE DIMENSIONAL ACCURACY OF DWG FEATURES RELATIVE TO THOSE PROPERTY LIMITS.

**APEGN**  
Certificate of Authorization  
KGS Group  
No. 245

ENGINEER'S SEAL  
PROVINCE OF MANITOBA  
R.B. OFFMAN  
Member  
24701  
REGISTERED PROFESSIONAL ENGINEER

**THE CITY OF WINNIPEG**  
PUBLIC WORKS DEPARTMENT  
TRANSPORTATION ENGINEERING DIVISION

PROJECT TITLE  
**2015 ALLEY RENEWAL PROGRAM**  
CONTRACT 1  
ASHBURN ST/VALOUR RD  
ELLICE AVE TO SARGENT AVE  
STA 2+25 TO 3+62.5

SHEET OF  
**02** OF **15**

COMPUTER FILE NAME  
**14-0107-031\_Contract 1**

CITY DRAWING NUMBER  
**C102**

EXISTING	LEGEND-PLAN	PROPOSED	EXISTING	LEGEND-PLAN	PROPOSED	EXISTING	LEGEND-PROFILE	PROPOSED
300 LBS	LAND DRAINAGE SEWER	300 LBS	TEST HOLE	---	---	---	---	---
250 WWS	WASTE WATER SEWER	250 WWS	GUY WIRE	---	---	---	---	---
---	GAS	---	LIGHT STANDARD	---	---	---	---	---
---	HYDRO	---	BACK OF CURB	---	---	---	---	---
---	M.T.S.	---	CONCRETE	---	---	---	---	---
150 WM	WATERMAIN	150 WM	ASPHALT	---	---	---	---	---
---	HYDRANT	---	PAVER	---	---	---	---	---
---	VALVE	---	SIDEWALK	---	---	---	---	---
---	MANHOLE	---	PROPERTY LINE	---	---	---	---	---
---	CATCH BASIN	---	SURVEY BAR	---	---	---	---	---
---	CURB INLET	---	GEODETIC BENCHMARK	---	---	---	---	---
---	POLES	---	ELEVATION	---	---	---	---	---

**LOCATION APPROVED UNDERGROUND STRUCTURES**

SUPV. U/G STRUCTURES COMMITTEE DATE

NOTE:  
LOCATION OF UNDERGROUND STRUCTURES AS SHOWN ARE BASED ON THE BEST INFORMATION AVAILABLE BUT NO GUARANTEE IS GIVEN THAT ALL EXISTING UTILITIES ARE SHOWN OR THAT THE GIVEN LOCATIONS ARE EXACT. CONFIRMATION OF EXISTENCE AND EXACT LOCATION OF ALL SERVICES MUST BE OBTAINED FROM THE INDIVIDUAL UTILITIES BEFORE PROCEEDING WITH CONSTRUCTION.

B.M. 37#25  
ELEV. 233.121

E. side Wall St. N. of Ellice Ave., Tbt. in W. Conc. Foundation No. 919/925 Wall St., 1m N. & 0.1m below scored Conc. block of S.W. Cor. of Bldg.

DESIGNED BY: **AKW**  
DRAWN BY: **DMW**  
CHECKED BY: **RBO**  
APPROVED BY: **[Signature]**

HOR. SCALE: 1:250  
VERTICAL: 1:50

ISSUED FOR TENDER: 15/02/23  
DATE: 15/02/23

I:\PWS\14-0107-031\14-0107-031\_Contract 1.dwg - Tab: 102 Plotted By: gloewen 02/23/2015 [Mon 9:30am] PLOT: 1:1 A-1