

ALLEY PAVEMENT PROFILE

SCALE: 1:250 HOR
1:10 VER

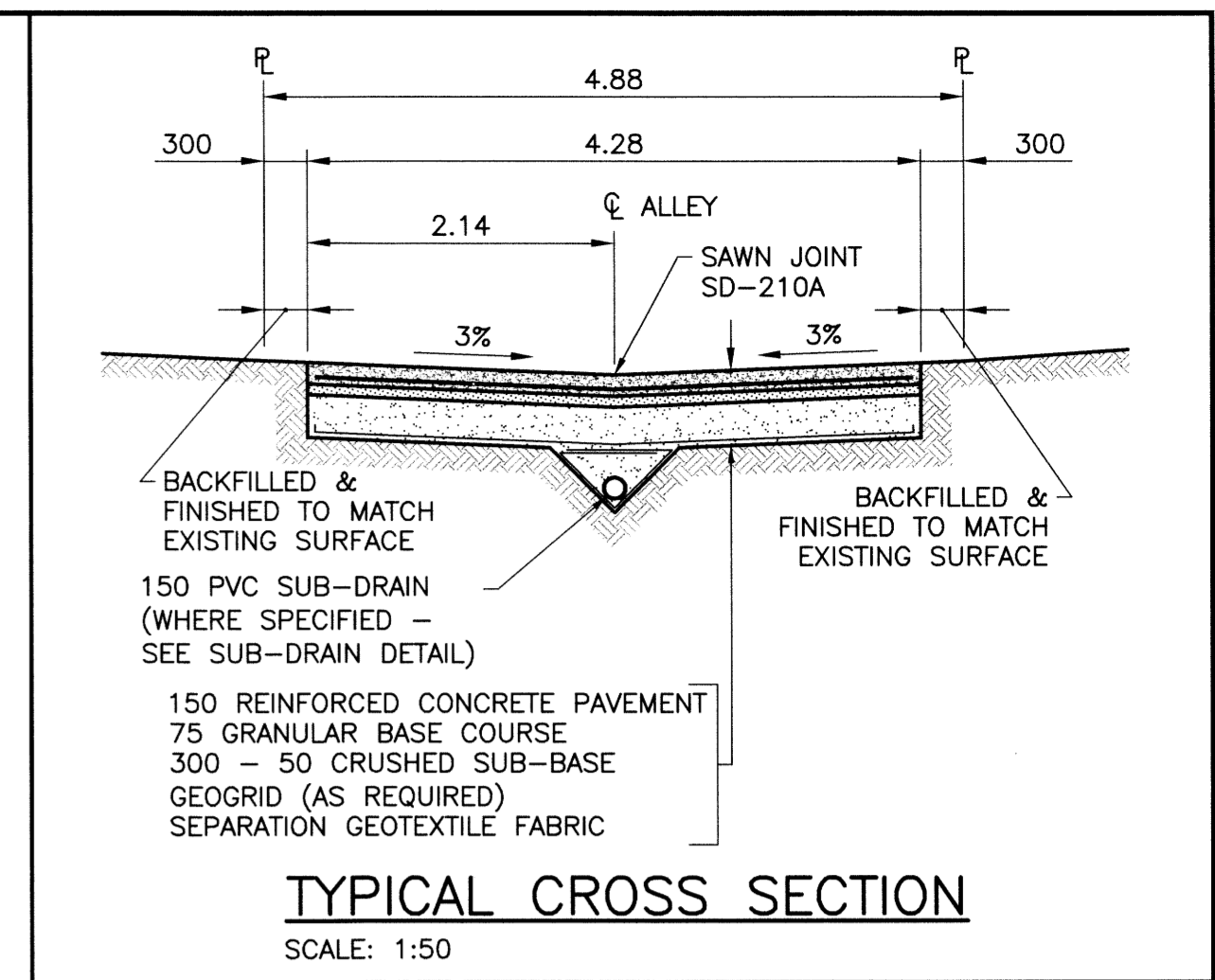

TYPICAL CROSS SECTION

SCALE: 1:50

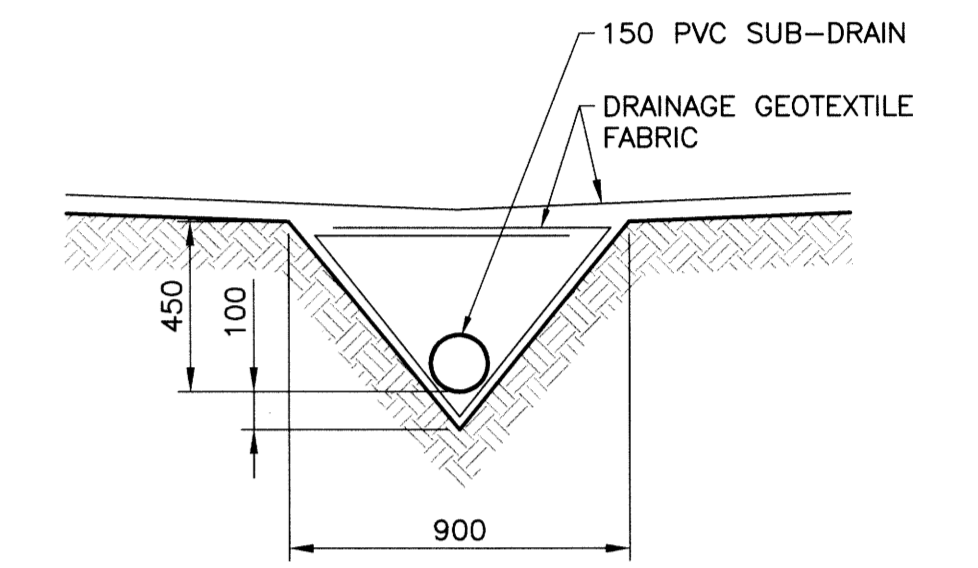

SUB-DRAIN DETAIL

SCALE: 1:20

NOTES

1. STATION CHAINAGE IS BASED ON CENTERLINE OF ALLEY RIGHT OF WAY.
2. ADJUST MH AND CB RIMS TO NEW GRADES.
3. PLUG SUB-DRAINS AT TERMINAL ENDS.
4. REGRADE EXISTING PRIVATE SIDEWALKS AS REQUIRED.
5. INSTALLATION OF LIP CURBS AND THEIR EXTENTS TO BE DETERMINED BY THE CONTRACT ADMINISTRATOR.
6. LIGHT STANDARDS, HYDRO POLES AND ANCHORS MAY REQUIRE TEMPORARY SUPPORT/REMOVAL OR REPLACEMENT AT THE CONTRACTOR'S EXPENSE.
7. ISOLATE ALL POLES, BASES AND PILES WITHIN ALLEY RIGHT OF WAY (SD-228C).
8. AVOID DAMAGE TO EXISTING TREES WITHIN THE LIMITS OF CONSTRUCTION.
9. CITY OF WINNIPEG SURVEY MONUMENTS EXIST ON THIS SITE. CONTRACTOR TO CONTACT THE CITY OF WINNIPEG GEOMATICS BRANCH 5 WORKING DAYS IN ADVANCE OF CONSTRUCTION TO COORDINATE MONUMENT PROTECTION SERVICES (204-918-1360).
10. ALLEY TO BE CONSTRUCTED IN PHASES AS SHOWN.
11. ALL EXCAVATIONS WITHIN 1.0m OF ANY NATURAL GAS MAIN MUST BE COMPLETED BY HAND OR HYDRO EXCAVATION.

MATCH LINE
STA 3+62.5

PHASE 2
STA 2+80.63 TO STA 4+82.20

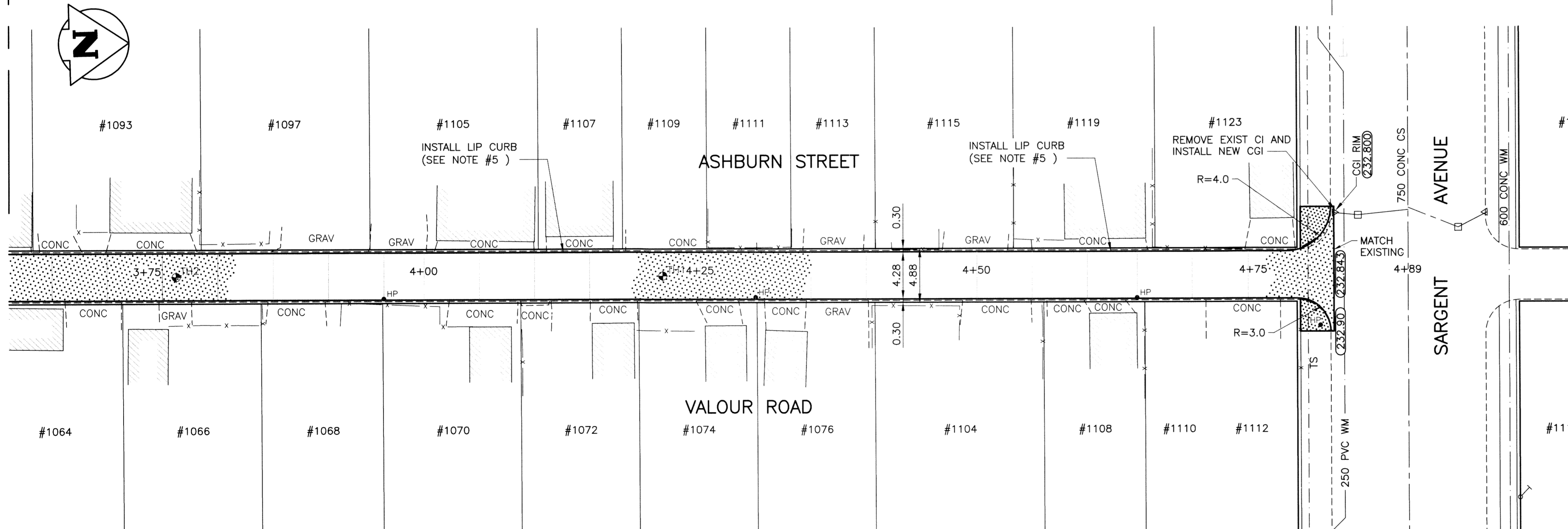

ALLEY PAVEMENT PLAN

SCALE: 1:250 HOR

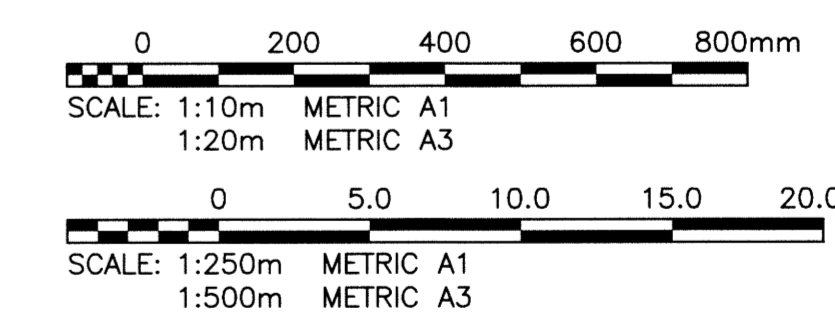

METRIC
WHOLE NUMBERS INDICATE MILLIMETRES
DECIMALIZED NUMBERS INDICATE METRES

PROPERTY LIMITS DELINEATION

WARNING
NOTIFY THE GAS COMPANY OF THE PROPOSED LOCATION OF EXCAVATION. TAKE PRECAUTION TO AVOID DAMAGE TO GAS COMPANY INSTALLATIONS. SEE PROVINCIAL REGULATION 210/72 FOR DETAILS.

DELINEATION OF PROPERTY LIMITS AS SHOWN ON THIS DWG DOES NOT REPRESENT A "LEGAL SURVEY". KGS GROUP MAKES NO REPRESENTATION OR WARRANTY AS TO THE ACCURACY OF PROPERTY LIMITS DELINEATED ON THIS DWG, NOR ON THE DIMENSIONAL ACCURACY OF DWG FEATURES RELATIVE TO THOSE PROPERTY LIMITS.

APEGM
Certificate of Authorization
KGS Group
No. 245

ENGINEER'S SEAL
R.B. OFFMAN
Member 24701
REGISTERED PROFESSIONAL ENGINEER

THE CITY OF WINNIPEG
PUBLIC WORKS DEPARTMENT
TRANSPORTATION ENGINEERING DIVISION

PROJECT TITLE
2015 ALLEY RENEWAL PROGRAM
CONTRACT 1
ASHBURN ST/VALOUR RD
ELLICE AVE TO SARGENT AVE
STA 3+62.5 TO SARGENT AVE

SHEET OF
03 OF **15**

COMPUTER FILE NAME
14-0107-031_Contract 1

CITY DRAWING NUMBER
C103

300 LBS	LAND DRAINAGE SEWER	300 LBS	TEST HOLE				
250 WWS	WASTE WATER SEWER	250 WWS	GUY WIRE				
	GAS		LIGHT STANDARD				
	HYDRO		BACK OF CURB				
	M.T.S.		CONCRETE				
150 WM	WATERMAIN	150 WM	ASPHALT				
	HYDRANT		SIDEWALK				
	VALVE		PROPERTY LINE				
	MANHOLE		SURVEY BAR				
	CATCH BASIN		GEODETIC BENCHMARK				
	CURB INLET		ELEVATION				
	POLES						
EXISTING	LEGEND-PLAN	PROPOSED	EXISTING	LEGEND-PLAN	PROPOSED	EXISTING	LEGEND-PROFILE

LOCATION APPROVED UNDERGROUND STRUCTURES

SUPV. U/G STRUCTURES COMMITTEE DATE

NOTE:
LOCATION OF UNDERGROUND STRUCTURES AS SHOWN ARE BASED ON THE BEST INFORMATION AVAILABLE BUT NO GUARANTEE IS GIVEN THAT ALL EXISTING UTILITIES ARE SHOWN OR THAT THE GIVEN LOCATIONS ARE EXACT. CONFIRMATION OF EXISTENCE AND EXACT LOCATION OF ALL SERVICES MUST BE OBTAINED FROM THE INDIVIDUAL UTILITIES BEFORE PROCEEDING WITH CONSTRUCTION.

B.M. 37#25
ELEV. 233.121

E. side Wall St. N. of Ellice Ave., Tbt. in W. Conc. Foundation No. 919/925 Wall St., 1m N. & 0.1m below scored Conc. block of S.W. Cor. of Bldg.

DESIGNED BY: **AKW**
DRAWN BY: **DMW**

CHECKED BY: **RBO**
APPROVED BY:

HOR. SCALE: 1:250
VERTICAL: 1:50

ISSUED FOR TENDER: 15/02/23
NO. REVISIONS: DATE: BY:

KGS GROUP
CONSULTING ENGINEERS

CONSULTANT DRAWING NO.
14-0107-031_103

U:\PMS\14-0107-031\14-0107-031_Contract 1.dwg - Tab: 103 Plotted By: gloswen 02/23/2015 [Mon 9:31am] PLOT 1:1 A-1