

ALLEY PAVEMENT PROFILE
SCALE: 1:250 HOR
1:10 VER

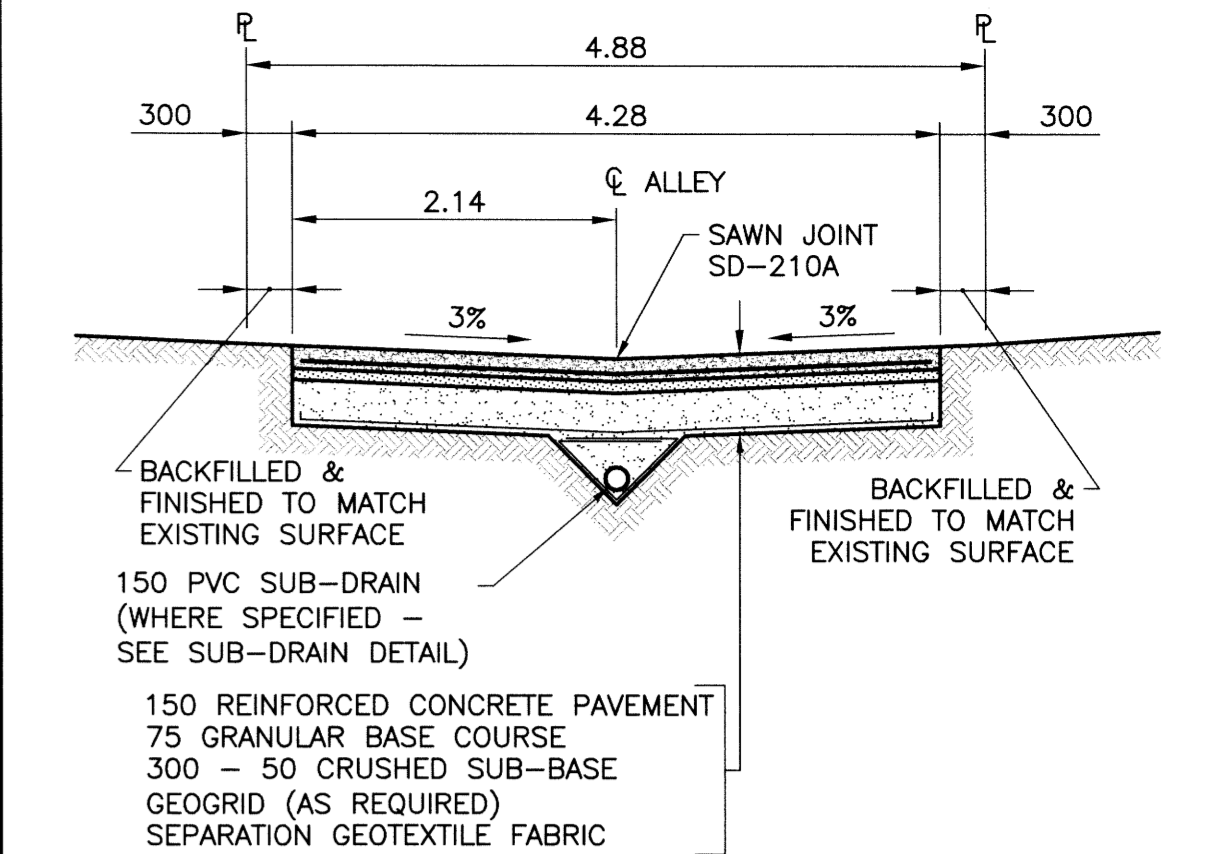

TYPICAL CROSS SECTION
SCALE: 1:50

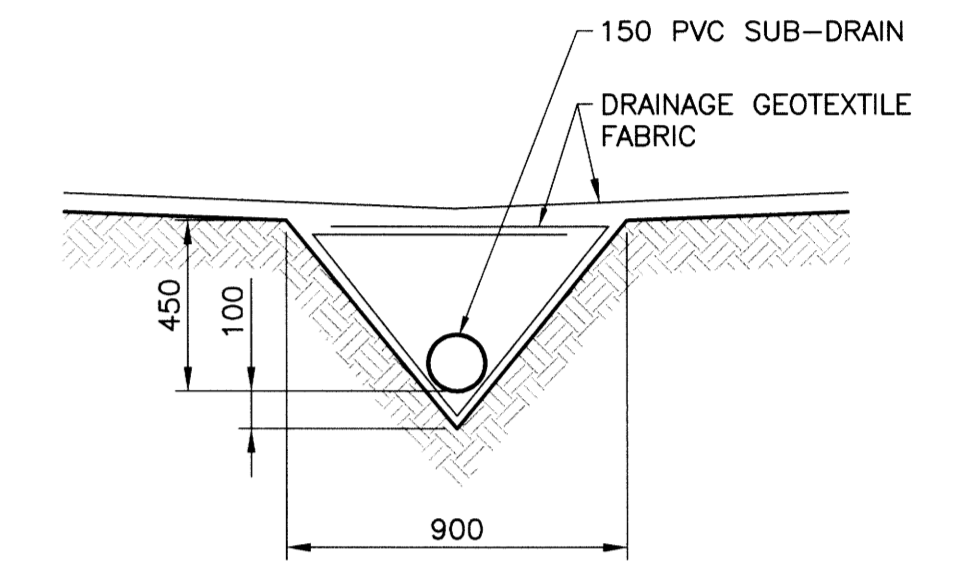

SUB-DRAIN DETAIL
SCALE: 1:20

- NOTES**
1. STATION CHAINAGE IS BASED ON CENTERLINE OF ALLEY RIGHT OF WAY.
 2. ADJUST MH AND CB RIMS TO NEW GRADES.
 3. PLUG SUB-DRAINS AT TERMINAL ENDS.
 4. REGRADE EXISTING PRIVATE SIDEWALKS AS REQUIRED.
 5. INSTALLATION OF LIP CURBS AND THEIR EXTENTS TO BE DETERMINED BY THE CONTRACT ADMINISTRATOR.
 6. LIGHT STANDARDS, HYDRO POLES AND ANCHORS MAY REQUIRE TEMPORARY SUPPORT/REMOVAL OR REPLACEMENT AT THE CONTRACTOR'S EXPENSE.
 7. ISOLATE ALL POLES, BASES AND PILES WITHIN ALLEY RIGHT OF WAY (SD-228C).
 8. AVOID DAMAGE TO EXISTING TREES WITHIN THE LIMITS OF CONSTRUCTION.
 9. CITY OF WINNIPEG SURVEY MONUMENTS EXIST ON THIS SITE. CONTRACTOR TO CONTACT THE CITY OF WINNIPEG GEOMATICS BRANCH 5 WORKING DAYS IN ADVANCE OF CONSTRUCTION TO COORDINATE MONUMENT PROTECTION SERVICES (204-918-1360).
 10. ALLEY TO BE CONSTRUCTED IN PHASES AS SHOWN.
 11. ALL EXCAVATIONS WITHIN 1.0m OF ANY NATURAL GAS MAIN MUST BE COMPLETED BY HAND OR HYDRO EXCAVATION.

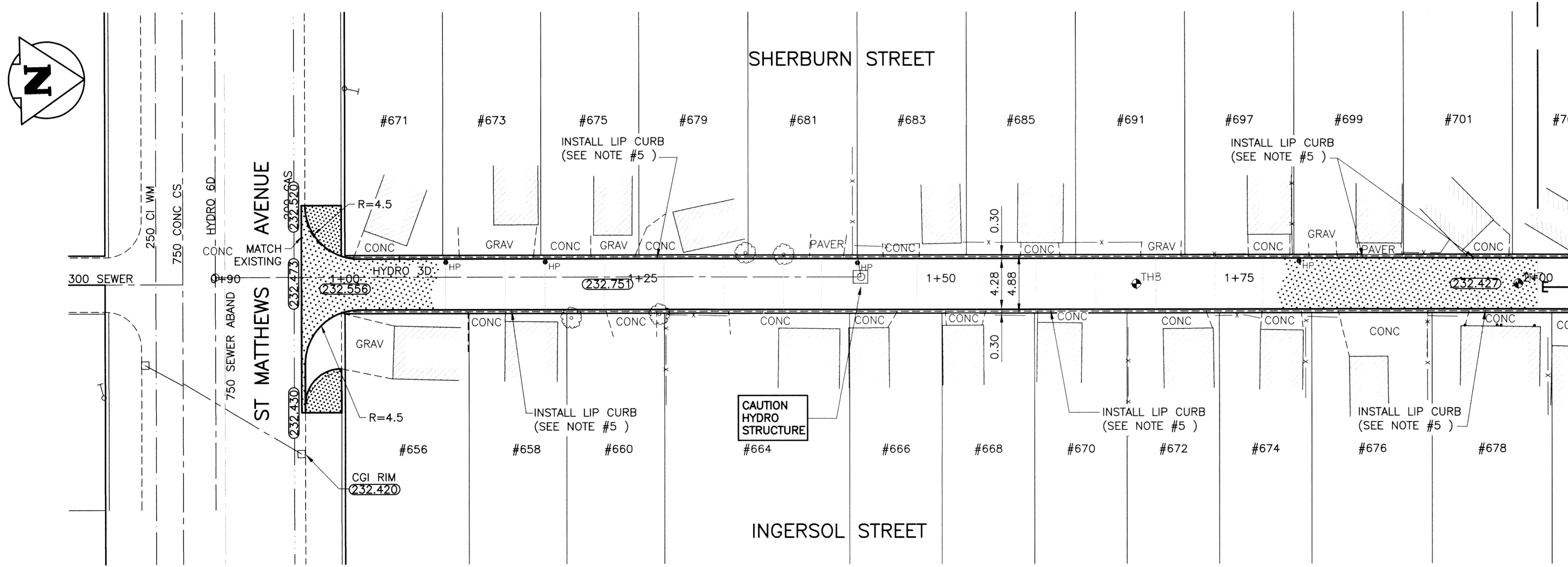

ALLEY PAVEMENT PLAN
SCALE: 1:250 HOR

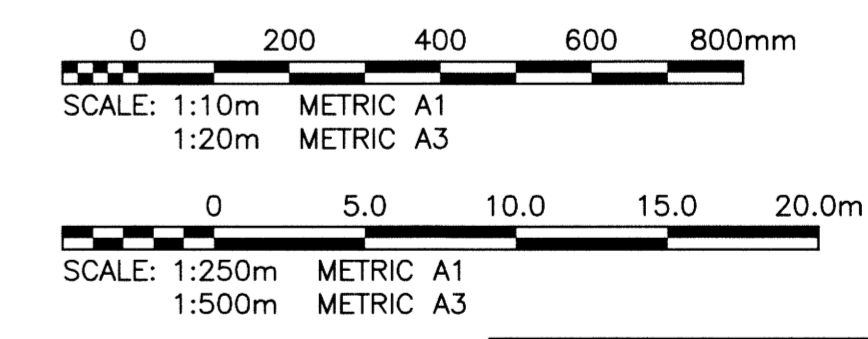

METRIC
WHOLE NUMBERS INDICATE MILLIMETRES
DECIMALIZED NUMBERS INDICATE METRES

PROPERTY LIMITS DELINEATION

WARNING
NOTIFY THE GAS COMPANY OF THE PROPOSED LOCATION OF EXCAVATION. TAKE PRECAUTION TO AVOID DAMAGE TO GAS COMPANY INSTALLATIONS. SEE PROVINCIAL REGULATION 210/72 FOR DETAILS.

DELINEATION OF PROPERTY LIMITS AS SHOWN ON THIS DWG DOES NOT REPRESENT A "LEGAL SURVEY". KGS GROUP MAKES NO REPRESENTATION OR WARRANTY AS TO THE ACCURACY OF PROPERTY LIMITS DELINEATED ON THIS DWG, NOR ON THE DIMENSIONAL ACCURACY OF DWG FEATURES RELATIVE TO THOSE PROPERTY LIMITS.

APEGM
Certificate of Authorization
KGS Group
No. 245

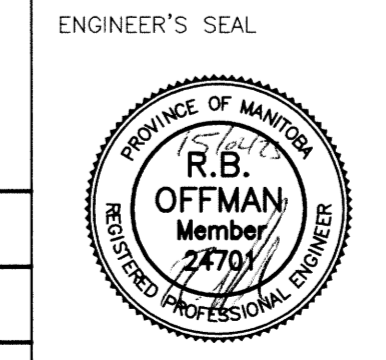

THE CITY OF WINNIPEG
PUBLIC WORKS DEPARTMENT
TRANSPORTATION ENGINEERING DIVISION

PROJECT TITLE
2015 ALLEY RENEWAL PROGRAM
CONTRACT 1
SHERBURN ST/INGERSOL ST
ST MATTHEWS AVE TO ELLICE AVE
ST MATTHEWS AVE TO STA 2+00

SHEET OF
08 OF **15**

COMPUTER FILE NAME
14-0107-031_Contract 1

CITY DRAWING NUMBER
C108

LOCATION APPROVED UNDERGROUND STRUCTURES

SUPV. U/G STRUCTURES COMMITTEE DATE

NOTE:
LOCATION OF UNDERGROUND STRUCTURES AS SHOWN ARE BASED ON THE BEST INFORMATION AVAILABLE BUT NO GUARANTEE IS GIVEN THAT ALL EXISTING UTILITIES ARE SHOWN OR THAT THE GIVEN LOCATIONS ARE EXACT. CONFIRMATION OF EXISTENCE AND EXACT LOCATION OF ALL SERVICES MUST BE OBTAINED FROM THE INDIVIDUAL UTILITIES BEFORE PROCEEDING WITH CONSTRUCTION.

B.M. 37#33	N.W. Cor. St. Matthews Ave. & Dominion St., Tolt in S. Lyndal stone foundation of Minto Armoury, 0.7m
ELEV. 233.716	
DESIGNED BY	AKW
CHECKED BY	RBO
DRAWN BY	DMW
APPROVED BY	
HOR. SCALE:	1:250
VERTICAL:	1:50
RELEASED FOR CONSTRUCTION:	
DATE	
NO. REVISIONS	
DATE	
BY	
DATE	

300 LBS	LAND DRAINAGE SEWER	300 LBS	TEST HOLE
250 WWS	WASTE WATER SEWER	250 WWS	GUY WIRE
	GAS		LIGHT STANDARD
	HYDRO		BACK OF CURB
	M.T.S.		CONCRETE
150 WM	WATERMAIN	150 WM	ASPHALT
	HYDRANT		SIDEWALK
	VALVE		PROPERTY LINE
	MANHOLE		SURVEY BAR
	CATCH BASIN		GEODETIC BENCHMARK
	CURB INLET		ELEVATION
	POLES		
EXISTING	LEGEND-PLAN	PROPOSED	EXISTING
			LEGEND-PLAN
			PROPOSED
			EXISTING
			LEGEND-PROFILE
			PROPOSED

U:\ENR\14-0107-031\14-0107-031_Contract 1.dwg - Tab: 108 Plotted By: glowen 02/23/2015 [Mon 9:34am] PLOT: 1:1 A-1