

ALLEY PAVEMENT PROFILE

SCALE: 1:250 HOR
1:10 VER

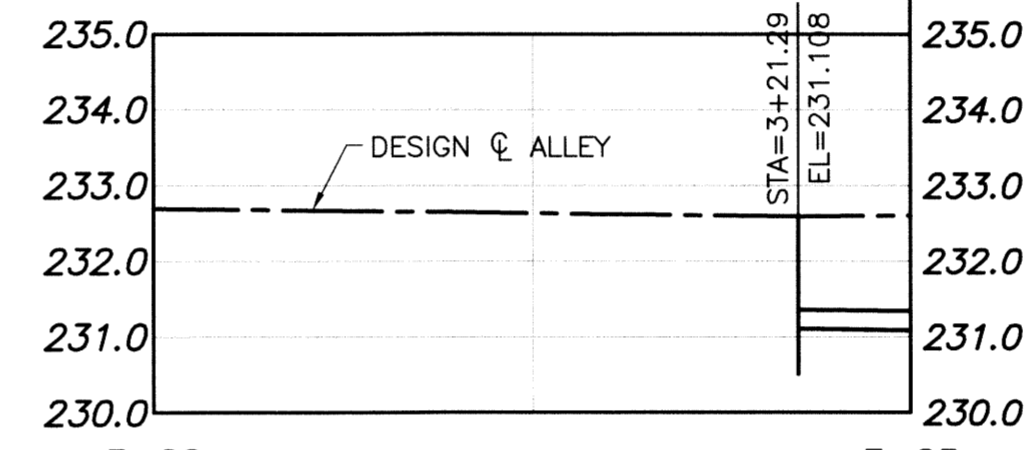

ALLEY SEWER PROFILE

SCALE: 1:250 HOR
1:100 VER

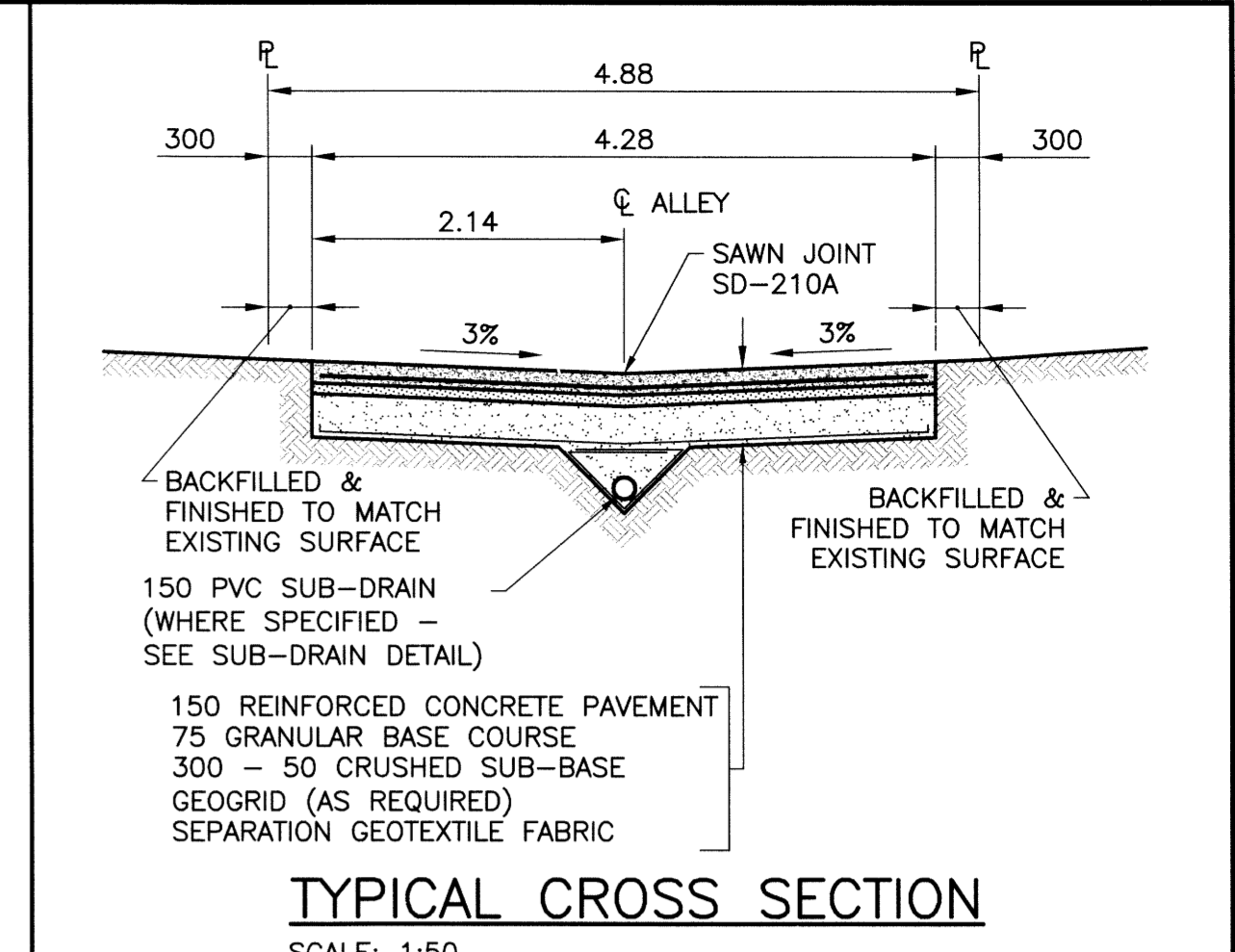

TYPICAL CROSS SECTION

SCALE: 1:50

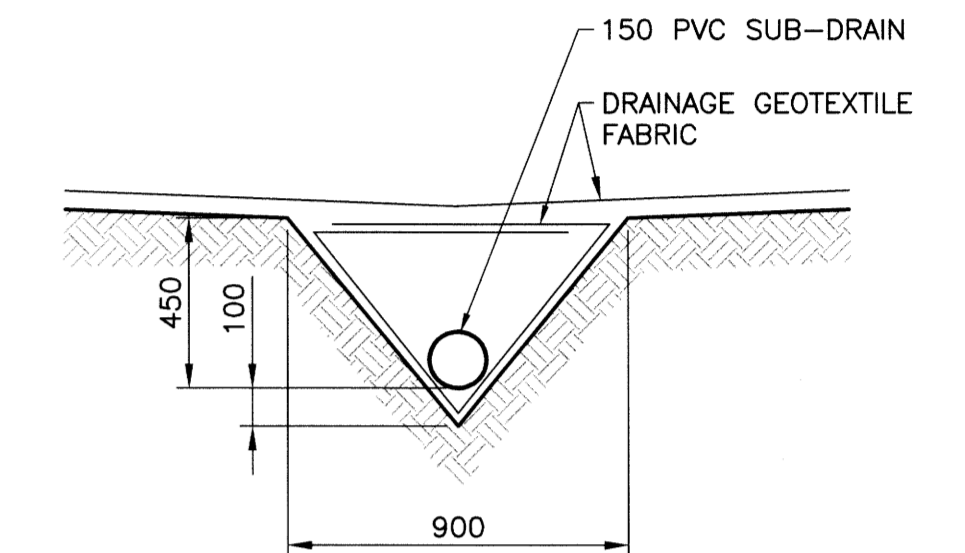

SUB-DRAIN DETAIL

SCALE: 1:20

NOTES

1. STATION CHAINAGE IS BASED ON CENTERLINE OF ALLEY RIGHT OF WAY.
2. ADJUST MH AND CB RIMS TO NEW GRADES.
3. PLUG SUB-DRAINS AT TERMINAL ENDS.
4. REGRADE EXISTING PRIVATE SIDEWALKS AS REQUIRED.
5. INSTALLATION OF LIP CURBS AND THEIR EXTENTS TO BE DETERMINED BY THE CONTRACT ADMINISTRATOR.
6. LIGHT STANDARDS, HYDRO POLES AND ANCHORS MAY REQUIRE TEMPORARY SUPPORT/REMOVAL OR REPLACEMENT AT THE CONTRACTOR'S EXPENSE.
7. ISOLATE ALL POLES, BASES AND PILES WITHIN ALLEY RIGHT OF WAY (SD-228C).
8. AVOID DAMAGE TO EXISTING TREES WITHIN THE LIMITS OF CONSTRUCTION.
9. CITY OF WINNIPEG SURVEY MONUMENTS EXIST ON THIS SITE. CONTRACTOR TO CONTACT THE CITY OF WINNIPEG GEOMATICS BRANCH 5 WORKING DAYS IN ADVANCE OF CONSTRUCTION TO COORDINATE MONUMENT PROTECTION SERVICES (204-918-1360).
10. ALLEY TO BE CONSTRUCTED IN PHASES AS SHOWN.
11. ALL EXCAVATIONS WITHIN 1.0m OF ANY NATURAL GAS MAIN MUST BE COMPLETED BY HAND OR HYDRO EXCAVATION.

MATCH LINE
STA 2+00

MATCH LINE
STA 3+25

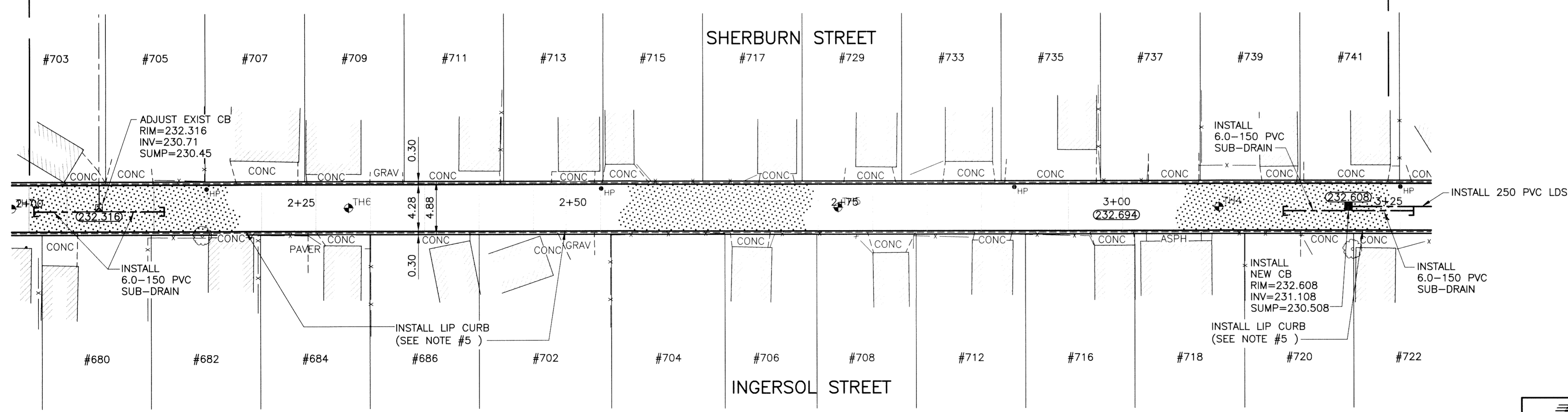
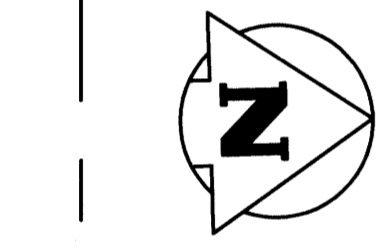

ALLEY PAVEMENT PLAN

SCALE: 1:250 HOR

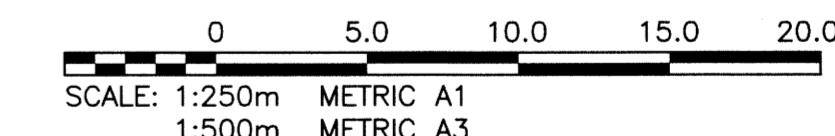
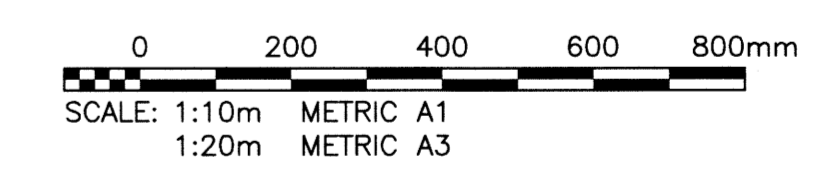

METRIC

WHOLE NUMBERS INDICATE MILLIMETRES
DECIMALIZED NUMBERS INDICATE METRES

PROPERTY LIMITS DELINEATION

WARNING

NOTIFY THE GAS COMPANY OF THE PROPOSED LOCATION OF EXCAVATION. TAKE PRECAUTION TO AVOID DAMAGE TO GAS COMPANY INSTALLATIONS. SEE PROVINCIAL REGULATION 210/72 FOR DETAILS.

DELINEATION OF PROPERTY LIMITS AS SHOWN ON THIS DWG DOES NOT REPRESENT A "LEGAL SURVEY". KGS GROUP MAKES NO REPRESENTATION OR WARRANTY AS TO THE ACCURACY OF PROPERTY LIMITS DELINEATED ON THIS DWG, NOR ON THE DIMENSIONAL ACCURACY OF DWG FEATURES RELATIVE TO THOSE PROPERTY LIMITS.

APCGM
Certificate of Authorization
KGS Group
No. 245



THE CITY OF WINNIPEG
PUBLIC WORKS DEPARTMENT
TRANSPORTATION ENGINEERING DIVISION

PROJECT TITLE
2015 ALLEY RENEWAL PROGRAM
CONTRACT 1
SHERBURN ST/INGERSOL ST
ST MATTHEWS AVE TO ELLICE AVE
STA 2+00 TO 3+25

SHEET OF
09 OF **15**

COMPUTER FILE NAME
14-0107-031_Contract 1

CITY DRAWING NUMBER
C109

CONSULTANT DRAWING NO.
14-0107-031_109

LOCATION APPROVED UNDERGROUND STRUCTURES		B.M. 37#33 ELEV. 233.716	N.W. Cor. St. Matthews Ave. & Dominion St., 10ft in S. Lyndall stone foundation of Mirlo Armoury, 0.7m
SUPPLY, U/G STRUCTURES COMMITTEE	DATE		
NOTE: LOCATION OF UNDERGROUND STRUCTURES AS SHOWN ARE BASED ON THE BEST INFORMATION AVAILABLE BUT NO GUARANTEE IS GIVEN THAT THE GIVEN LOCATIONS ARE EXACT. CONFIRMATION OF EXISTENCE AND EXACT LOCATION OF ALL SERVICES MUST BE OBTAINED FROM THE INDIVIDUAL UTILITIES BEFORE PROCEEDING WITH CONSTRUCTION.			
NO.	REVISIONS	DATE	BY

DESIGNED BY		CHECKED BY	
AKW		RBO	
DRAWN BY		APPROVED BY	
DMW			
HOR. SCALE: 1:250		RELEASED FOR CONSTRUCTION:	
VERTICAL: 1:50		DATE	

EXISTING	LEGEND-PLAN	PROPOSED	EXISTING	LEGEND-PLAN	PROPOSED	EXISTING	LEGEND-PROFILE	PROPOSED
300 LBS	LAND DRAINAGE SEWER	300 LBS	TEST HOLE					
250 WWS	WASTE WATER SEWER	250 WWS	GUY WIRE					
	GAS		LIGHT STANDARD					
	HYDRO		BACK OF CURB					
	M.T.S.		CONCRETE					
150 WM	WATERMAIN	150 WM	ASPHALT					
	HYDRANT		SIDEWALK					
	VALVE		PROPERTY LINE					
	MANHOLE		SURVEY BAR					
	CATCH BASIN		GEODETIC BENCHMARK					
	CURB INLET		ELEVATION					
	POLES							