

ALLEY PAVEMENT PROFILE

SCALE: 1:250 HOR
1:10 VER

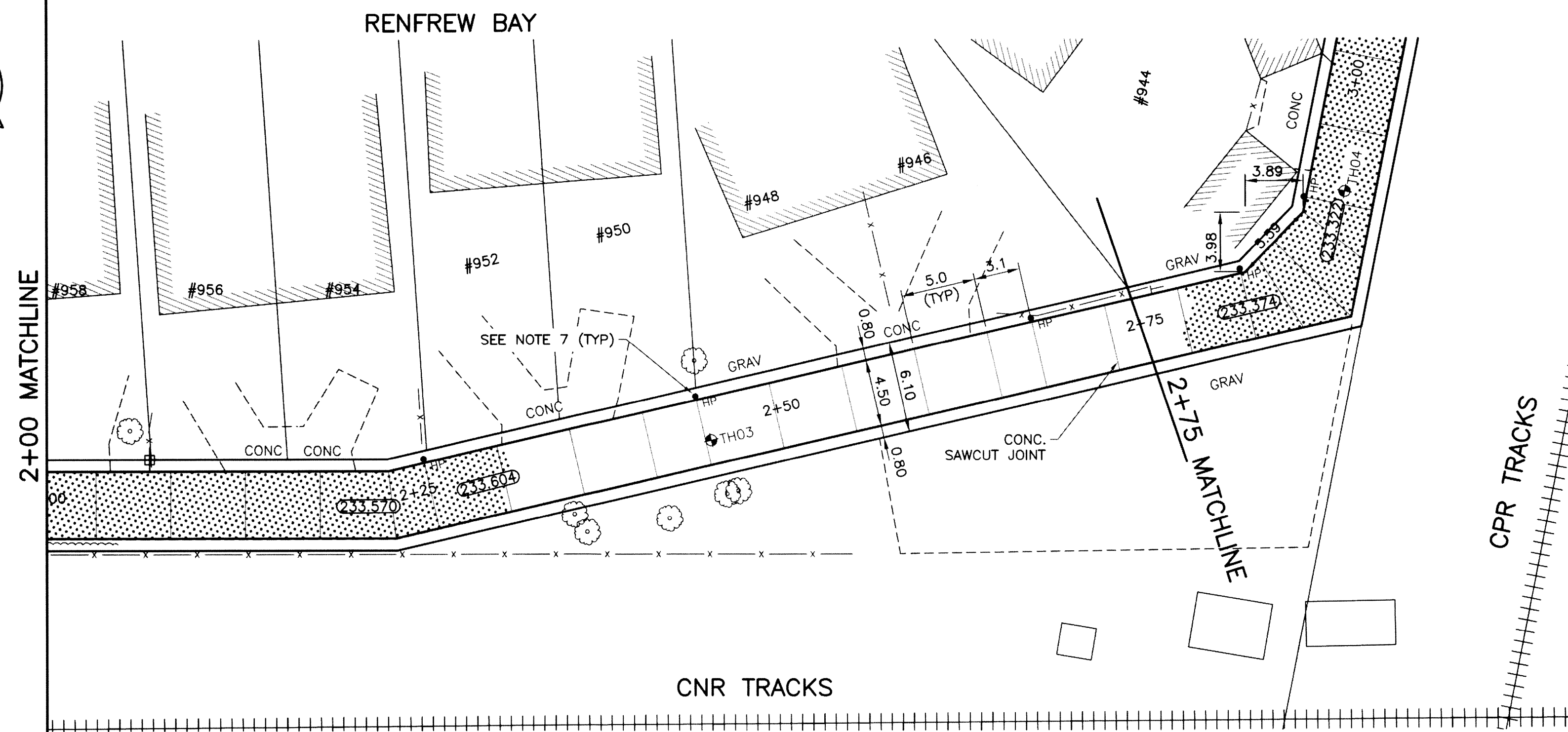

ALLEY PAVEMENT PLAN

SCALE: 1:250 HOR

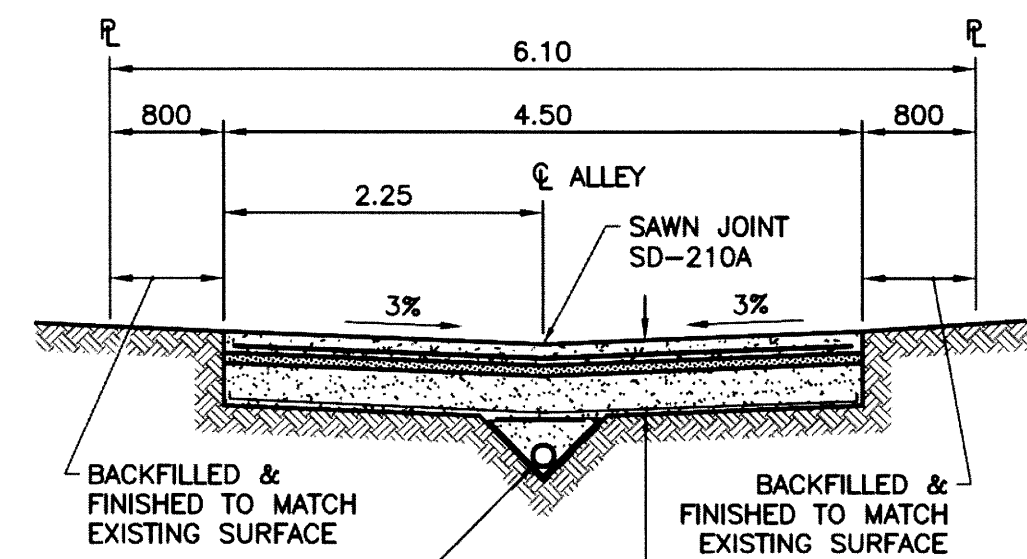

TYPICAL CROSS SECTION

SCALE: 1:50

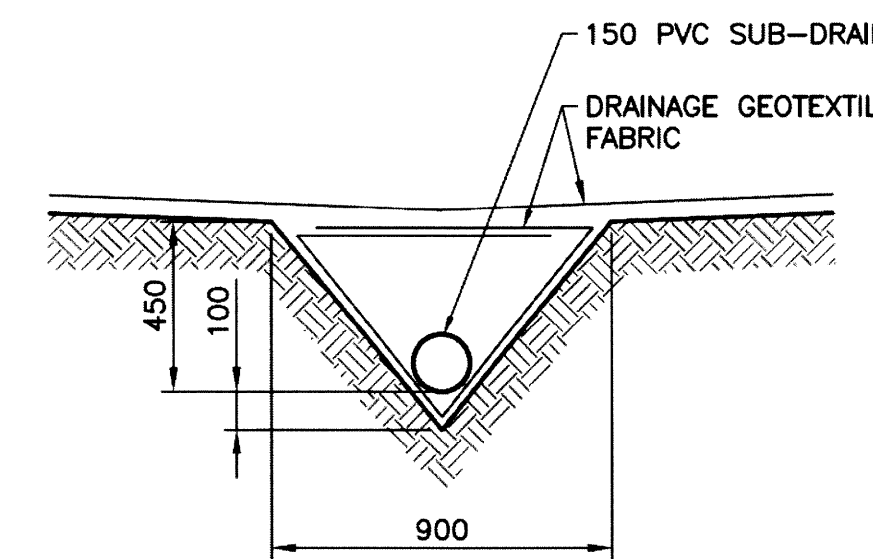

SUB-DRAIN DETAIL

SCALE: 1:20

NOTES

1. STATION CHAINAGE IS BASED ON CENTERLINE OF ALLEY RIGHT OF WAY.
2. ADJUST MH AND CB RIMS TO NEW GRADES.
3. PLUG SUB-DRAINS AT TERMINAL ENDS.
4. REGRADE EXISTING PRIVATE SIDEWALKS AS REQUIRED.
5. INSTALLATION OF LIP CURBS AND THEIR EXTENTS TO BE DETERMINED BY THE CONTRACT ADMINISTRATOR.
6. LIGHT STANDARDS, HYDRO POLES AND ANCHORS MAY REQUIRE TEMPORARY SUPPORT/REMOVAL OR REPLACEMENT AT THE CONTRACTOR'S EXPENSE.
7. ISOLATE ALL POLES, BASES AND PILES WITHIN ALLEY RIGHT OF WAY (SD-228C).
8. AVOID DAMAGE TO EXISTING TREES WITHIN THE LIMITS OF CONSTRUCTION.
9. CITY OF WINNIPEG SURVEY MONUMENTS EXIST ON THIS SITE. CONTRACTOR TO CONTACT THE CITY OF WINNIPEG GEOMATICS BRANCH 5 WORKING DAYS IN ADVANCE OF CONSTRUCTION TO COORDINATE MONUMENT PROTECTION SERVICES (204-918-1360).
10. ALLEY TO BE CONSTRUCTED IN PHASES AS SHOWN.
11. ALL EXCAVATIONS WITHIN 1.0m OF ANY NATURAL GAS MAIN MUST BE COMPLETED BY HAND OR HYDRO EXCAVATION.

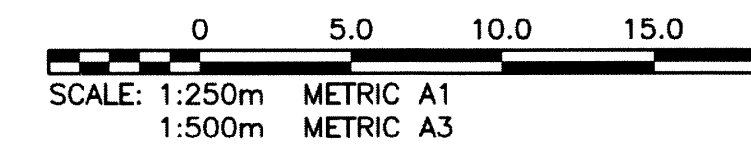
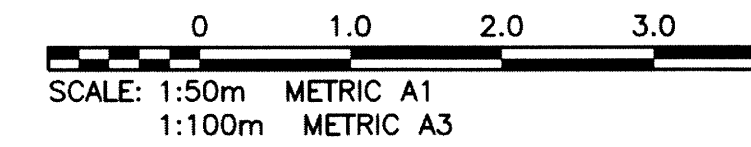
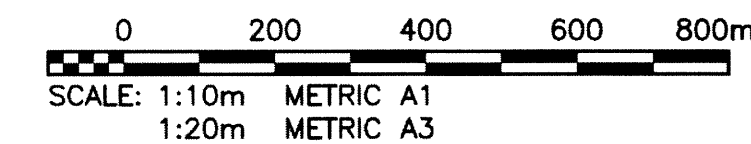
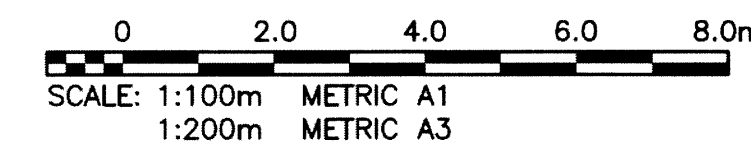

METRIC

WHOLE NUMBERS INDICATE MILLIMETRES
DECIMALIZED NUMBERS INDICATE METRES

PROPERTY LIMITS DELINEATION

WARNING

NOTIFY THE GAS COMPANY OF THE PROPOSED LOCATION OF EXCAVATION. TAKE PRECAUTION TO AVOID DAMAGE TO GAS COMPANY INSTALLATIONS. SEE PROVINCIAL REGULATION 210/72 FOR DETAILS.

DELINEATION OF PROPERTY LIMITS AS SHOWN ON THIS DWG DOES NOT REPRESENT A "LEGAL SURVEY". KGS GROUP MAKES NO REPRESENTATION OR WARRANTY AS TO THE ACCURACY OF PROPERTY LIMITS DELINEATED ON THIS DWG, NOR ON THE DIMENSIONAL ACCURACY OF DWG FEATURES RELATIVE TO THOSE PROPERTY LIMITS.

APEGN
Certificate of Authorization
KGS Group
No. 245

ENGINEER'S SEAL
M.C. ROWBOTHAM
REGISTERED PROFESSIONAL ENGINEER
MARCH 9, 2015

THE CITY OF WINNIPEG
PUBLIC WORKS DEPARTMENT
TRANSPORTATION ENGINEERING DIVISION

PROJECT TITLE
2015 ALLEY RENEWAL PROGRAM
CONTRACT 2
RENFREW BAY
TAYLOR AVE TO TAYLOR AVE
STA 2+00 TO STA 2+75

SHEET OF
12 OF **15**

COMPUTER FILE NAME
14-0107-031_Contract 2

CITY DRAWING NUMBER
C212

LOCATION APPROVED UNDERGROUND STRUCTURES

SUPV. U/G STRUCTURES COMMITTEE DATE

NOTE:
LOCATION OF UNDERGROUND STRUCTURES AS SHOWN ARE BASED ON THE BEST INFORMATION AVAILABLE BUT NO GUARANTEE IS GIVEN THAT ALL EXISTING UTILITIES ARE SHOWN OR THAT THE GIVEN LOCATIONS ARE EXACT. CONFIRMATION OF EXISTENCE AND EXACT LOCATION OF ALL SERVICES MUST BE OBTAINED FROM THE INDIVIDUAL UTILITIES BEFORE PROCEEDING WITH CONSTRUCTION.

B.M. 51-003	S.W. Cor. Renfrew Bay E. & Taylor Ave. 1/4 in E. City Foundation No. 1600 Taylor Ave. 2.3 m S. of N.E. Cor. & 0.1 m below typical stone of 8kg
ELEV. 234.300	
DESIGNED BY	GES
CHECKED BY	RBO
DRAWN BY	GES
APPROVED BY	CK
HOR. SCALE:	1:250
VERTICAL:	1:50
ISSUED FOR TENDER	15/03/09
RELEASSED FOR CONSTRUCTION:	
NO. REVISIONS	DATE BY
0	
DATE	2015/02/05

300 LGS	LAND DRAINAGE SEWER	300 LGS	- x - x -	FENCE	
250 WWS	WASTE WATER SEWER	250 WWS	⊕	TEST HOLE	
	GAS		—	GUY WIRE	
	HYDRO		—	LIGHT STANDARD	
	M.T.S.		—	BACK OF CURB	
150 WM	WATERMAIN	150 WM	—	CONCRETE	
⊕	HYDRANT	⊕	—	ASPHALT	
⊗	VALVE	⊗	—	SIDEWALK	
○	MANHOLE	○	—	PROPERTY LINE	
□	CATCH BASIN	□	—	SURVEY BAR	
▽	CURB INLET	▽	⊕	GEODETIC BENCHMARK	
•	POLES	•	—	ELEVATION	231.334
EXISTING	LEGEND-PLAN	PROPOSED	EXISTING	LEGEND-PLAN	PROPOSED
			EXISTING	LEGEND-PROFILE	PROPOSED

P:\Projects\2014\14-0107-031_Dwg\Main\14-0107-031_Contract 2.dwg - Tab: C212 Plotted By: gloewen 03/09/2015 [Mon 9:29am] PLOT 1:1 A-1