



The City of Winnipeg
Water & Waste Department

Identification Standard

Document Code: 510276-0000-40ER-0002
Revision: 00

Approved By:

Geoff Patton, Manager of Engineering

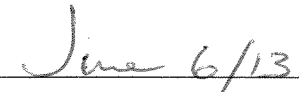
Date

REVISION REGISTER					
Rev.	Description	Date	By	Checked	Approved
00	Issued for City Use	2013-05-31	C. Reimer	C. Reimer	C. Reimer

This document is owned and maintained by the Asset Management Branch of the Engineering Services Division. For questions, comments or revisions please contact the Asset Management Branch Head.

TABLE OF CONTENTS

1	Introduction	7
1.1	Scope of the Standard	7
1.2	Application	7
1.2.1	Re-identification	8
2	General.....	9
2.1	General Identification Requirements	9
2.2	Facility Code	10
2.3	Process Area	10
2.4	Functional Designations	11
2.5	Equipment Number.....	12
2.5.1	Uniqueness.....	12
2.5.2	Number of Digits.....	12
2.5.3	Equipment Number Ranges	13
2.6	Subcomponents.....	13
2.6.1	Subcomponent Identifier Format	13
2.6.2	Use of Subcomponent System.....	14
2.6.3	Subcomponent Examples	14
3	Architectural	17
3.1	Buildings	17
3.2	Room Identifier	17
3.2.1	Building Level Designation	18
3.2.2	Drawing Representation.....	19
3.2.3	Room Numbering Guidelines	19
4	Mechanical / Process Equipment	21
4.1	Identifier Format	21
4.2	Functional Designations	22
4.3	HVAC Miscellaneous Components	25
4.4	Subcomponents.....	26
5	Piping	27
5.1	Pipe Designation	27
5.1.1	Nominal Pipe Sizes	28
5.1.2	Fluid Commodity Codes	29
5.1.3	Piping Material.....	33
5.2	Piping Components	34
5.2.1	Manual Valve Identifier Format – Minor Valves	34
5.2.2	Manual Valve Identifier Format – Major Valves and Valves with Instrumentation.....	36
5.2.3	Check Valve and Strainer Identifier Format	37
5.2.4	Cathodic Protection Components.....	37
5.2.5	Sample P&ID	38
6	Electrical	39
6.1	Equipment Identifier Format	39
6.2	Electrical Functional Designations	40
6.3	Type Modifier	42

6.4	Device-Specific Identifier Formats.....	43
6.4.1	Receptacle Identifiers	43
6.4.2	Power Cables Associated with Identified Equipment	44
6.4.3	General Purpose Cables – Lighting & Receptacles	45
6.4.4	Junction Boxes - Power.....	46
6.4.5	Interlock Keys	47
6.4.6	Wire Tags	48
6.4.7	Tie Circuit Breakers	52
6.5	Subcomponents.....	54
6.6	Examples.....	56
6.6.1	Identification by Load Equipment	56
6.7	Fire Alarm System Devices	57
6.7.1	Identifier Format	57
6.7.2	Fire Alarm Device Designations	58
6.7.3	Drawing Format.....	58
6.8	Security Devices.....	59
6.8.1	Device Identifier Format	59
6.8.2	Security Device Designations.....	60
6.8.3	Security Equipment Designations	60
6.8.4	Equipment Subcomponent Designations	61
7	Automation	63
7.1	Instrumentation.....	63
7.1.1	Instrument Identifier Format	63
7.1.2	Drawing Format.....	64
7.1.3	Instrument Functional Designations	65
7.1.4	Type Clarification.....	69
7.1.5	Valve Identification	71
7.2	Automation Equipment.....	73
7.2.1	Identifier Format	73
7.2.2	Functional Designations.....	74
7.2.3	IT Equipment Designations	75
7.3	Automation Cables	76
7.3.1	Instrumentation Cables.....	76
7.3.2	Cables Associated with Identified Equipment	77
7.4	Sample P&ID	78
7.5	Wire Tags	79
7.5.1	Power Circuits within Control Panels	79
7.5.2	Control Circuits	80
7.5.3	Analog Signal Circuits - Instruments	81
7.5.4	I/O Wiring.....	82
7.6	Subcomponents.....	83
7.7	Software Configuration File Naming.....	84
7.8	I/O and Signal Tags.....	85
7.8.1	Discrete Input Signals.....	85
7.8.2	Discrete Output Signals.....	87
7.8.3	Analog Signals Generated From Equipment.....	88
7.8.4	Analog Measured Signals Generated From Instruments.....	89
7.8.5	Analog Output Signals.....	90
7.8.6	Control System Software Implementation.....	90
8	Communication Equipment.....	91

	Identification Standard	Revision: 00	Page 5 of 120
		Document Code: 510276-0000-40ER-0002	

8.1	Identifier Format	91
8.2	Functional Designations	92
8.3	Network Cables	93
Appendix A	Facility Codes.....	95
Appendix B	Facility Process Area Codes.....	104
Appendix C	Master Equipment Functional Designations	110
Appendix D	Equipment Number Ranges	115
Appendix E	Sample Drawings	119

	Identification Standard	Revision: 00	Page 7 of 120
		Document Code: 510276-0000-40ER-0002	

1 INTRODUCTION

This Water and Waste Department Identification Standard is to be referenced for consistent and accurate identification for all process, mechanical, electrical, and automation equipment. The standard also provides guidance regarding architectural room identification and communication equipment. This document provides clear guidance to department personnel, as well as external consultants, regarding appropriate equipment identification. A consistent standard has been developed for all Water and Waste groups, including Collections, Land Drainage, and Solid Waste (as applicable), however it is acknowledged that some exceptions for various groups may be required due to special circumstances, or existing established precedent.

1.1 Scope of the Standard

This identification standard applies to all City-owned Water and Wastewater facilities, which includes the following facilities:

- The Water Treatment Plant
- Regional water pumping stations
- The Shoal Lake Intake Facility
- Remote water facilities, including standpipes, valve chambers, boathouses, etc.
- Wastewater treatment facilities
- Wastewater lift stations
- Flood pumping stations
- Underpass sites
- Wastewater diversion stations
- Deep well locations
- Fountain locations
- Land drainage facilities
- Combined Sewer Overflow facilities
- Current and future remote wastewater sites (outfalls, valve chambers, etc).

1.2 Application

Existing facilities do not necessarily comply with this standard. The expectations regarding application of this standard to existing facilities must be decided on a case-by-case basis, however general guidelines for application are presented as follows:

- All new facilities must comply completely with this standard.
- All major upgrades to a facility, or a larger facility's process area, must completely comply with this standard. Any existing equipment within the area being upgraded should be re-identified.
- All minor upgrades should utilize this standard as far as practical for new equipment, however in some cases compromise with the existing facility identification practice may be required.

 Winnipeg	Identification Standard	Revision: 00	Page 8 of 120
		Document Code: 510276-0000-40ER-0002	

For example, if adding a single pump to the WEWPCC facility, it is recommended to identify the pump as S230-P, rather than P-S230.

1.2.1 Re-identification

When equipment is re-identified to this new standard, it is recommended that the following be implemented:

- All equipment lamacoids and labels are to be replaced with the new identifier.
- All drawings that are being modified as part of the work are to utilize the new identifier. Major drawings such as P&IDs and Single Line Diagrams should display both the new and the old identifiers, in the following format:

New-Identifier
(was Old-Identifier)

- Generate a master equipment list with the new identifier, old identifier, and equipment description.

	Identification Standard	Revision: 00	Page 9 of 120
		Document Code: 510276-0000-40ER-0002	

2 GENERAL

2.1 General Identification Requirements

General identification requirements are as follows:

- Unambiguous Identity
 - All equipment identifiers shall be unique. No two pieces of equipment within the same facility are to share a common identifier.
- Consistency
 - The identification system is to be consistent across all facilities.
 - Prior to addition of a new identifier type, all new additions to the standard should be vetted by a group, to avoid inconsistent additions to the standard.
 - Spaces within identifiers are not permitted. For example, PNL M10 is not a substitute for PNL-M10.

Allowable characters in equipment identifiers are as follows:

- Uppercase letters A through Z
- Numerals 0 through 9
- Hyphen “-“ (or underscore “_” in software packages where hyphens are not supported)
- Period “.”(or underscore “_” in software packages where periods are not supported)

No other symbols or characters or spaces shall be utilized in an identifier.

	Identification Standard	Revision: 00	Page 10 of 120
		Document Code: 510276-0000-40ER-0002	

2.2 Facility Code

Each City of Winnipeg facility is assigned a unique, four-digit facility code. The facility code is to be used on drawings and documentation as required. The facility code appears within all City drawing numbers, but need not be shown within the content of the drawing. The facility code is deemed an optional component of equipment and instrument identifiers, with the preference to omit the facility code to reduce the overall length of identifiers.

Systems such as a central Supervisory Control and Data Acquisition (SCADA) system that monitors multiple facilities are to make use of the facility code to segregate components by facility. The implementation of the facility code may be by means of a hierarchical directory system whereby individual components are stored under a folder that is named by the facility code. If the database or system where the identifier is being stored supports an additional field for the facility code, or is based upon a hierarchical system where the identifier can be placed as a component off of a root facility branch, it is deemed to be acceptable to omit the Facility Code in the instrument identifier. For example, the City's current Computerized Work Management System (CWMS) has an integral asset list, where a field is provided for the facility. In this case, the facility code for the equipment identifier would not be entered.

A complete list of facility codes is provided in Appendix A.

2.3 Process Area

The process area code identifies the physical area or building in which the equipment is located. A single letter character from A to Z represents a process area. Some specific recommendations regarding implementation and designation of process areas are:

- For new construction, ensure that process areas are allocated for a large enough area, such that the 26 available process area codes are not exhausted.
- The process area represents the physical location of the equipment, not the equipment function. For example, a hot water pump located in the P area is designated as having a P process area, not a B (Boilers) process area. This is much more straightforward for both assignment and maintenance personnel.
 - Note however, that in some cases there are multiple pieces of equipment, all associated with the same primary piece of equipment, but in different physical process areas. In this case, the equipment process area should be selected based upon the major or primary equipment. For example, the motor starter for pump P-M101 would be identified as MS-M101, even if the motor starter is in the S process area. The motor starter is directly associated with the pump and it would be confusing and unsafe to have different identifiers. An example is provided in Section 6.6.1.
- For similar facilities, it is beneficial, but not mandatory, that similar process codes are utilized. For example, ideally the letter P should represent the Primary Clarifier process area at all wastewater treatment plants, but would represent something different for water facilities.

The process areas for existing facilities are listed in Appendix B.

	Identification Standard	Revision: 00	Page 11 of 120
		Document Code: 510276-0000-40ER-0002	

2.4 Functional Designations

The functional designation represents the function of the equipment. A complete list functional designations, for all disciplines, is shown in Appendix C.

It may be required to add new functional designations, where the existing list does not cover a new application. It is recommended that the following be reviewed prior to the addition of new designations:

- Functional designations for equipment are to be limited to a maximum of four characters. While most instrument designations will be four characters or less, it is possible to have up to five characters in a instrumentation designation, as per ISA 5.1.
- Utilize general, rather than specific, functional designations. For example, utilize the general pump designation P and avoid specific pump designations such as:
 - CWSP Chilled Water Supply Pump
 - CHRP Chilled Water Return Pump
 - ELP Effluent Lift Pump
 - CFP Chemical Feed Pump
 - SLP Sludge Pump
- Update the master list in Appendix C, and ensure there is no overlap with other disciplines.
- It is acceptable to re-utilize an existing designation at an existing facility, even if is not listed in Appendix C, if it is deemed that there are too many existing documentation references to modify. In this case, the designation will be a unique special case, and is not to be added to Appendix C.
- Consider the use of the letter U to designate the equipment if the quantity of the equipment is low.

2.5 Equipment Number

2.5.1 Uniqueness

The equipment number is a number utilized to identify a specific instance of a piece of equipment within a certain process area. Equipment numbers may be re-used within different process areas.

Generally, equipment numbers should be unique for each piece of equipment, but equipment that is functionally related, and has a one-to-one relationship, may (but is not required to) share a common equipment number. The overall equipment identifier must still be unique. See Figure 2-1 for an example.

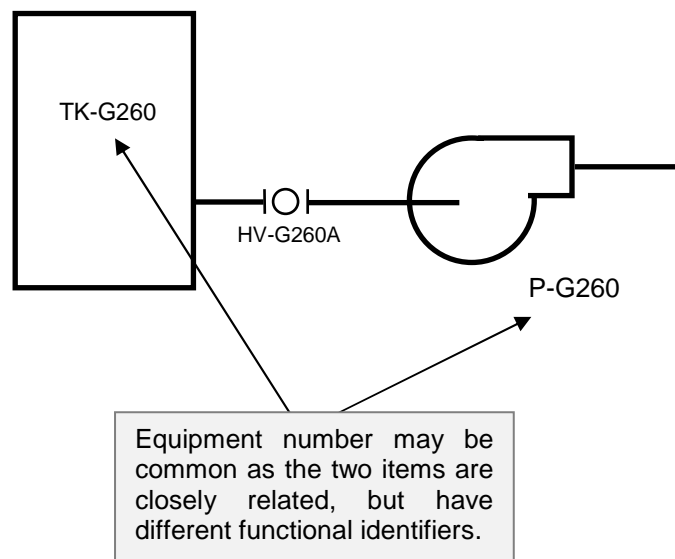

Figure 2-1: Equipment Number Example – Functionally Related

Note that electrical and mechanical equipment, that is not functionally related, must not share a common equipment number. For example, a MCC-M100, and a P-M100 should not exist within the same facility.

2.5.2 Number of Digits

Equipment numbers will typically be comprised of three digits in medium to large size facilities. However in small facilities, with less than 50 equipment identifiers, it is permissible to utilize two digit equipment numbers. Use of two digit equipment numbers will be typical for most Collections facilities, such as wastewater lift stations and flood pumping stations. Note that where two digit equipment numbers are utilized, the instrument loop number will also be shortened by a digit, to a total of three digits.

2.5.3 Equipment Number Ranges

For each facility, the equipment numbers are grouped and allocated in ranges to specific process functions. The range allocations are on a site by site basis, although efforts should be made to utilize common ranges for similar types of facilities.

Equipment number ranges are defined in Appendix D.

2.6 Subcomponents

In some cases, it is appropriate for equipment to be designated as a component of another identified piece of equipment, rather than an independent unit. Equipment subcomponents will typically be expressed as using a dot “.” field, followed by the subcomponent identifier.

2.6.1 Subcomponent Identifier Format

E*	.	SSSS	-	N
Equipment Identifier		Subcomponent Functional Designation	-	Subcomponent Number

Where,

- E* is the *Equipment Identifier*, of the base equipment, as designated in this document.
- SSSS is the *Subcomponent Functional Designation*, which is one to four letters. Typical subcomponent designations are shown in other sections of this document.
- N is the *Subcomponent Number*, an optional field to be utilized when there are multiple subcomponents within the base equipment.

Some examples of subcomponents are as follows:

- CMP-R521.LOP Lube oil pump for compressor CMP-R521, where the pump is integrated into the compressor skid and driven by the compressor motor.
- PNL-P712.MCB Panelboard PNL-P712 main breaker
- VFD-G612.RCTR-1 Line reactor for VFD-G612 (integrated in VFD enclosure)

In a full hierarchical system, almost every piece of equipment could potentially be viewed as a subcomponent or child of another system. For example, an agitator could potentially be viewed as a component of a tank. However, this approach would lead to an extensive hierarchical system that is not recommended for general plant identification. Thus, the following rules of thumb are presented as a guide for classification of an item as a subcomponent.

Identification of a device as a subcomponent should be considered when:

- The device is a constituent component that is physically enclosed in, or attached to, the larger equipment;
- The device is normally grouped as a component of the larger equipment when the equipment is purchased; and
- Operations personnel would normally refer to the device as a component of the larger equipment, rather than a separate device.

2.6.2 Use of Subcomponent System

It is deemed that there are numerous benefits to utilizing the subcomponent system, as indicated below:

- Due to the naming structure of subcomponents, it is clear as to what parent component the subcomponent belongs to.
- Subcomponents allow for smaller instrument bubbles to show functionality such as limit switches, without wasting drawing space. For devices such as large multi-turn actuators, with internal torque switches, hand switches, and limit switches, as well as many other types of equipment, this can be a significant savings in drawing space without any loss of identification capability.
- The use of subcomponents helps avoid the case where the subcomponent devices are placed on the equipment or instrument list, and confuse personnel because they cannot be found in the field. This is also particularly important to construction personnel, who must coordinate the purchase, storage, installation, and commissioning of these devices.
- The use of subcomponents aligns more closely with the current direction of control system software implementations, where the database and system model have hierarchical attributes, rather than a simple linear list of tags.

2.6.3 Subcomponent Examples

Two examples of the use of subcomponents are shown in Figure 2-2 and Figure 2-3.

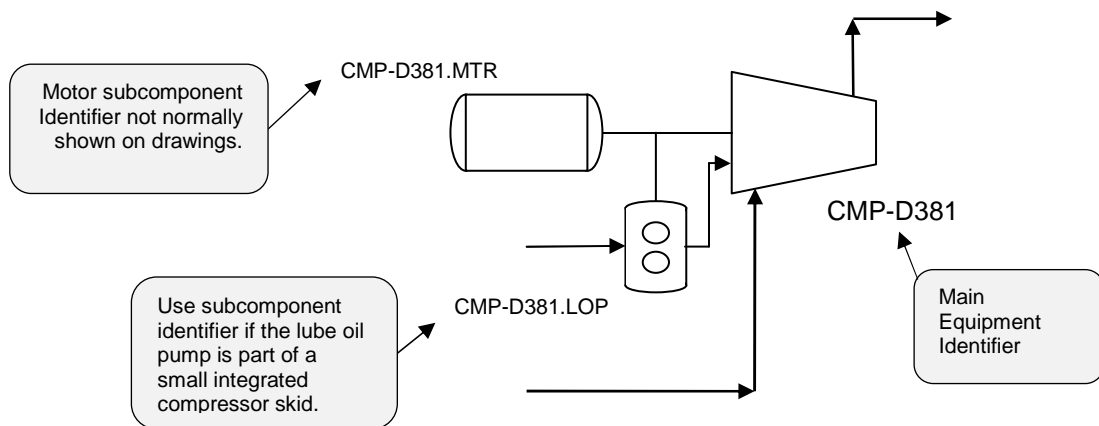

Figure 2-2 : Lube-Oil Pump Subcomponent Example

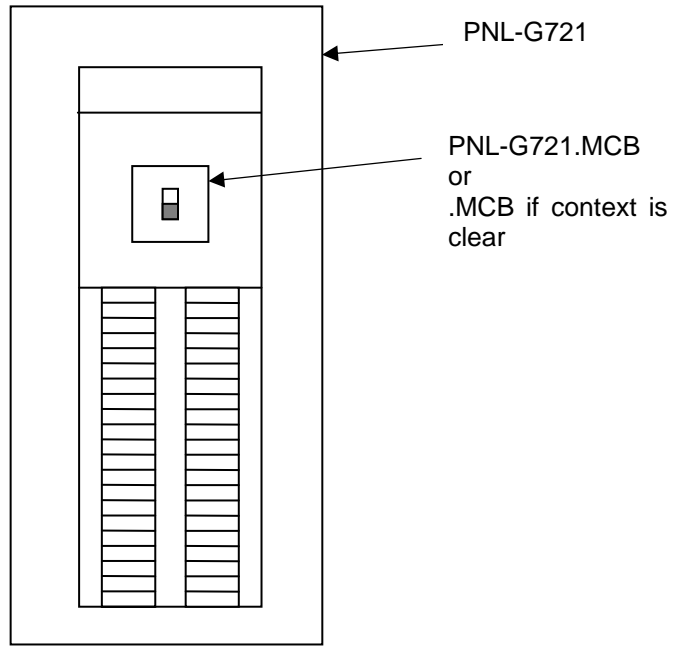

Figure 2-3 : Electrical Subcomponent Example – Main Circuit Breaker

3 ARCHITECTURAL

3.1 Buildings

3.2 Room Identifier

It is required to identify room numbers for architectural purposes and to allow for identification of specific equipment that is associated with rooms. Fire alarm system and security system component identification, as discussed in Sections 6.7 and 6.8, are associated with room numbers. Room numbers will be identified as follows:

FFFF	-	RM	-	P	-	L	RR	S
Facility Code (Optional)	-	Room Designation	-	Process Area	-	Level	Room Number	Suffix (Optional)

Where,

- FFFF is the *Facility Code*, from Appendix A. The *Facility Code* will typically be implied, and would only be fully written where required.
- RM is the *Room Designation*, which is comprised of the letters RM.
- P is the *Process Area*, which is based on Section 2.3.
- L is the *Level*, which shall typically be one or two characters, as described in Section 3.2.1.
- RR is the *Room Number*, which shall typically be two digits, except as described in Section 3.2.1.
- S is the *Suffix*, which can be utilized to indicate room divisions as required.

Examples:

- RM-S-115 Room 15 in the Secondary Clarifier process area, on the main level.
- RM-M-222 Room 22 in the Main Building process area, on the second level.
- RM-G-BA9 Room 9 in the Grit process area, lower level 2.

Note: A hyphen is utilized between the process area and level, to ensure that room numbers are not potentially confused with equipment numbers.

3.2.1 Building Level Designation

The building level designation shall be based upon Table 3-1 below.

Table 3-1 : Building Level Identifiers

Level	Description	Room Number Digits	Example
4	Fourth Floor	2	RM-M-405
3	Third Floor	2	RM-M-320
2	Second Floor	2	RM-M-251
1	Main / First Floor	2	RM-M-123
B	Lower Level 1 / Basement	2	RM-M-B52
BA	Lower Level 2	1	RM-M-BA5
BB	Lower Level 3	1	RM-M-BB1
EX	Exterior (See Note 4)	1	RM-M-EX1

Notes:

1. *Level 1 should be the uppermost floor entered at grade or at most, one half stair flight above.*
2. *Large mezzanines shall be numbered as a whole floor. Example: When a mezzanine exists between the first floor and the next whole floor, it will be numbered as the second floor and the next whole floor would be the 3rd floor.*
3. *Usable attic floors and penthouse levels should be numbered as if they are whole floors. For example, a two-story penthouse atop a three floor building will be numbered as the fourth and fifth floors. Do not use prefixes such as "R" for roof level.*
4. *Use of the EX designation for exterior spaces is optional. One example where this designation may be required is for outdoor security equipment. It is recommended that the outdoor space be designated into zones, which replace the room number.*

3.2.2 Drawing Representation

Room numbers on drawings may be presented as shown in Figure 3-1. Note that the room designation “RM” may be omitted on drawings, when used with the ellipse symbol.

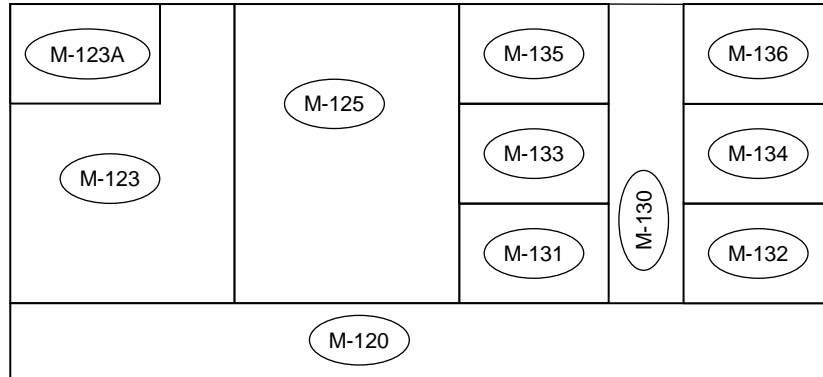

Figure 3-1 : Room Numbering on Drawings – Plan View

3.2.3 Room Numbering Guidelines

Utilize the following as a guide for room numbering:

- Numbers should flow from one end of the building to the other.
- Where corridors are present, use odd numbers on one side of a corridor and even numbers on the other side.
- Skip numbers as required to maintain succession of room numbering
 - In some instances, room numbers on one side of a corridor shall be skipped in order to maintain succession with the room numbers on the opposite side of the corridor. This may occur, for example, when a suite of rooms or large space is accessed through a single door and there are no other doors on that same side until further down the corridor. This will allow for future renovations that may convert suites or large spaces into separate or small rooms with a corridor door.
- Use alphabetic suffixes for small rooms entered from other rooms
 - For example, a small storage space off of room M-123 could be designated as M-123A.
- Provide all accessible spaces with room numbers.
 - In addition to rooms, all interior spaces that can be directly accessed, such as corridors, vestibules, stairwells, elevator shafts, and accessible pipe spaces shall be numbered in a manner as consistent as possible with standard room spaces. Where doors or walls separate different areas of these spaces, each area shall receive its own unique number.

- Identify stairwells with a single room identifier, with the main floor as the level. If the stairwell is not accessible from the main floor, utilize the access level closest to the main floor as room level designation. See Figure 3-2 for examples.

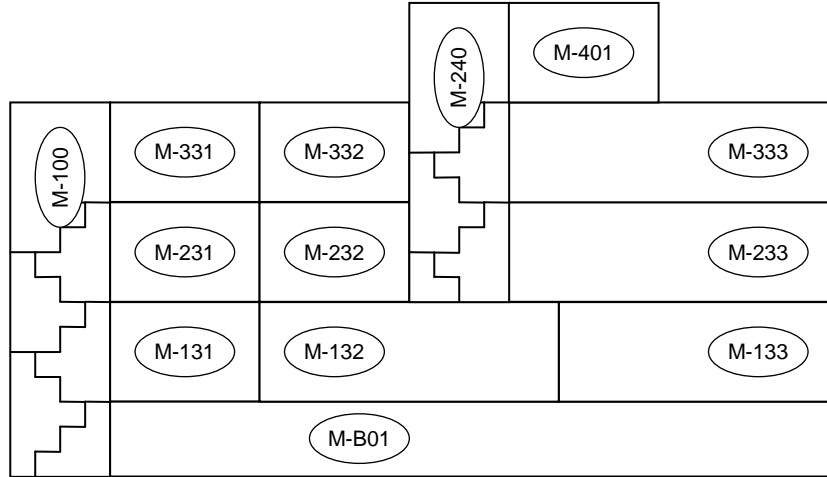

Figure 3-2 : Stairwell Identification Examples – Elevation View

- Rooms that span multiple levels should be identified with a level corresponding to the primary access level. See Figure 3-2 for examples of multi-level room identification.

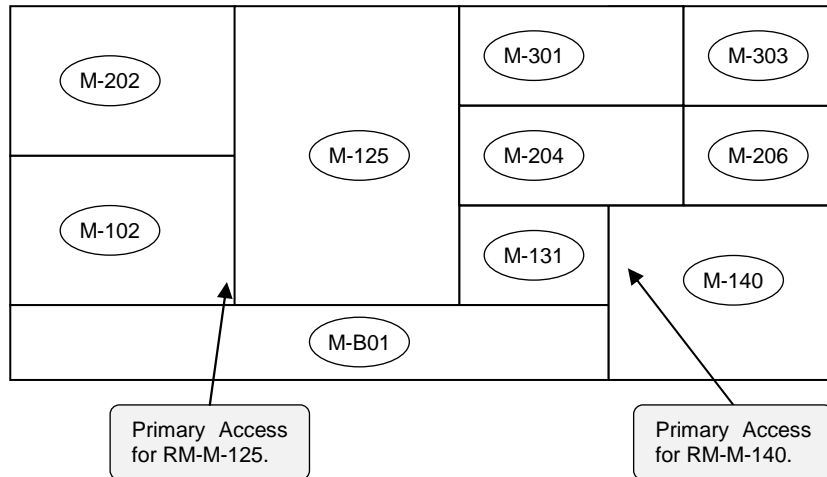

Figure 3-3 : Multi-Level Room Examples – Elevation View

4 MECHANICAL / PROCESS EQUIPMENT

4.1 Identifier Format

Mechanical / process equipment will be identified as follows:

FFFF	-	EEEE	-	P	NNN
Facility Code (Optional)	-	Equipment Functional Designation	-	Process Area	Equipment Number

Where,

- FFFF** is the *Facility Code*, from Appendix A. The *Facility Code* will typically be implied, and would only be fully written where required.
- EEEE** is the *Equipment Functional Designation*, which is comprised of 1 to 4 characters from Section 4.2.
- P** is the *Process Area*, which is based on Section 2.3.
- NNN** is the *Equipment Number* of the associated equipment. This will be three digits for medium to larger facilities, but will be two digits for smaller facilities, such as Collections facilities.

Examples:

- CMP-G201** A compressor in the G process area.
- P-M645** A glycol pump in the M process area.
- R-R102** An oxygen reactor in the R process area.
- SF-F61** A supply fan in a flood station. Note the two digit equipment number for Collections facilities.
- P-L01** The first lift pump in a wastewater lift station. Note that the equipment number for collections facilities in only two digits long.

4.2 Functional Designations

The functional designation represents the function of the equipment. A complete list functional designations is shown in Table 4-1.

Table 4-1 : Process / Mechanical Equipment Functional Designations

Functional Designation	Description	Notes
AD	Air Dryer	
AF	Aeration Fan	
AG	Agitator	
AHU	Air Handling Unit	Includes make-up air unit.
B	Blower	
BD	Balance Damper	See Section 4.3.
BFP	Back Flow Preventer	
BLR	Boiler	
BS	Bar Screen	
CAL	Calibration Column	
CC	Cooling Coil	
CDR	Condenser	
CE	Centrifuge	
CHLR	Chiller	
CM	Clarifier Mechanism	
CMP	Compressor	
CNV	Conveyor	Includes skimmers
CRN	Crane	
CT	Cooling Tower	
CU	Condensing Unit	
CV	Check Valve	See Section 5.2
EF	Exhaust Fan	
F	Fan - General	
FA	Flame Arrestor	
FC	Fan Coil	
FD	Fire Damper	Utilize same equipment number as air handler.
FDR	Feeder	Examples screw feeder, chlorinator, glycol make-up unit
FEX	Fire Extinguisher	
FG	Flap Gate	
FIL	Filter	
GR	Grille – General	See Section 4.3.
GRD	Grille – Diffuser	

	Identification Standard	Revision: 00	Page 23 of 120
		Document Code: 510276-0000-40ER-0002	

Functional Designation	Description	Notes
HC	Heating Coil	
HCE	Heating Coil, Electric	Duct based heater.
HE	Heat Exchanger	
HO	Hoist	
HOP	Hopper	
HP	Heat Pump	
HRC	Heat Recovery Coil	
HTR	Heater	General heaters, radiant, convectors, etc.
HUM	Humidifier	
HV	Hand/Manual Valve	See Section 5.2
INJ	Injector	
MXR	Mixer	
OD	Overhead Door	
P	Pump	
R	Reactor (various processes)	
RES	Reservoir	Large water containment structure.
S	Skid Package	
SA	Sampler	
SCBR	Scrubber	
SF	Supply Fan	
SL	Stop Logs	
SLG	Sluice Gate	
STR	Strainer	See Section 5.2
TK	Tank	
TU	Terminal Unit (HVAC)	Includes CAV/VAV/Dual Duct boxes. Dampers are to be identified as per Section 7.1 – Instrumentation.
U	Miscellaneous Equipment Not In List	e.g. water softener
UH	Unit Heater	
UVR	Ultra-Violet (UV) Reactor	
V	Vessel, Pressure Vessel	e.g. air receiver, glycol expansion tank
W	Weir	
WGB	Waste Gas Burner	

 Winnipeg	Identification Standard	Revision: 00	Page 24 of 120
		Document Code: 510276-0000-40ER-0002	

Notes:

1. *Equipment Functional Designations are to be unique, including electrical, automation, communication, and security equipment. Instrument Functional Designations may overlap Equipment Functional Designations.*
2. *See Appendix C for a master list of Equipment Functional Designations.*

4.3 HVAC Miscellaneous Components

Miscellaneous HVAC components will be identified as follows:

FFFF	-	EEEE	-	P	NNN	-	XX
Facility Code (Optional)	-	Equipment Functional Designation	-	Process Area	Equipment Number	-	Component Number

Where,

FFFF is the *Facility Code*, from Appendix A. The *Facility Code* will typically be implied, and would only be fully written where required.

EEEE is the *Equipment Functional Designation*, which is comprised of 2 to 4 characters from Section 4.2.

P is the *Process Area*, which is based on Section 2.3.

NNN is the *Equipment Number* of the associated equipment. Where an equipment number is not associated, allocate an equipment number.

XX is the *Component Number*, which can be one or two digits, and will increment starting at 1.

Examples:

FD-G601-5 the fifth fire damper associated with air handling unit AHU-G601.

GD-M645-1 The first diffuser grille associated with SF-M645.

GR-P682-22 The 22nd grille associated with SF-P682.

4.4 Subcomponents

The following designations are to be utilized for mechanical equipment subcomponents. See Section 2.6 for general rules on application of subcomponents.

Table 4-2 : Mechanical Equipment Subcomponents

Subcomponent Designation	Description	Notes
CMP	Compressor	e.g. component of a chiller.
F	Fan	
LOP	Lube Oil Pump	
MTR	Motor	
SWP	Swash Plate	
VSD	Variable Speed Drive	Includes fluid couplings and magnetic couplings. Utilize electrical VFD designation for variable frequency drives.

Examples:

P-G261.MTR	The motor associated with P-G261.
CMP-M502.LOP	The lube oil pump associated with compressor CMP-M502.
CHLR-M621.CMP-1	Compressor 1 of chiller CHLR-M621.

5 PIPING

5.1 Pipe Designation

The identification format for piping is as follows.

P	-	CCC	-	MMNN	-	LLLL
Pipe Nominal Size	-	Fluid Commodity Code	-	Pipe Specification Code (Optional)	-	Line Number (Optional)

Where,

- P** is the nominal pipe size in metric millimetres, and may be from 1 to 4 digits. See Table 5-1. For rectangular conduits and ducts, express the size as width x height. See example below.
- CCC** is the *Fluid Commodity Code*, which is 2 to 4 characters from Section 5.1.2.
- MMNN** is the optional *Pipe Specification Code*, where MM is the material, and NN is a number referencing the specific specification. Note that MM must be letters. See Notes 1 and 2.
- LLLL** is the optional *Line Number*. The *Line Number* must be unique across the entire facility, for each *Fluid Commodity Code*. See Note 3.

Note:

1. *It is recommended that a common set of pipe specifications be developed for each type of facility.*
2. *For existing facilities, where the exact pipe specification is not known, the Pipe Specification Code may be omitted.*
3. *It is not expected that Line Numbers will be utilized on all projects. Coordinate with the City project manager for specific requirements regarding the applicability of Line Numbers.*
4. *The Fluid Commodity Code together with the Line Number must be unique across the facility, where Line Numbers are utilized.*

Examples:

- | | |
|------------------|---|
| 150-PW-CS11 | A 150mm (6") potable water pipe, with specification code CS11. No line numbers utilized. |
| 600-RAS | A 600mm (24") Return Activated Sludge pipe, with an unknown pipe specification and no line number. |
| 600x1200-SE | A 600 x 1200mm secondary effluent conduit. The pipe/conduit specification and line number are not specified. |
| 25-CLG-SS31-1151 | A 25mm (1") chlorine gas pipe, with pipe specification SS31, and line number 1151. |
| 400-RW-CS52-1151 | A 400mm (16") chlorine gas pipe, with pipe specification SS31, and line number 1151. Note that this could be in the same facility as piping 25-CLG-SS31-1151. |

1350-TRW-040

A 1350mm diameter treated water pipe. The pipe specification code is omitted. The line number code 040 is differentiated from the pipe specification code in that it does not begin with a letter.

5.1.1 Nominal Pipe Sizes

Table 5-1 : Nominal Pipe Sizes (Metric)

mm	Inches	mm	Inches	mm	Inches	mm	Inches
3	1/8	75	3	275	11	750	30
6	1/4	90	3 1/2	300	12	800	32
10	3/8	100	4	350	14	850	34
12	1/2	112	4 1/2	400	16	900	36
20	3/4	125	5	450	18	950	38
25	1	150	6	500	20	1000	40
32	1 1/4	175	7	550	22	1100	44
38	1 1/2	200	8	600	24	1200	48
50	2	225	9	650	26	1300	52
65	2 1/2	250	10	700	28	1400	56

5.1.2 Fluid Commodity Codes

Table 5-2 : Fluid Commodity Code Designations

Code	Commodity - Water	Commodity - Wastewater
AA	Aqua Ammonia	
AHP	Air, High Pressure	
ALP	Air, Low Pressure	Air, Low Pressure
AS	Air Scour	
BS	Brine Solution	
BWS	Backwash Supply	
BWW	Backwash Wastewater	
CA	Compressed Air	Compressed Air
CCW	Circulating Cooling Water	
CDR	Condenser Water Return	Condenser Water Return
CDS	Condenser Water Supply	Condenser Water Supply
CE		Centrate
CG		Calibration Gas
CHR	Chilled Water Return	Chilled Water Return
CHS	Chilled Water Supply	Chilled Water Supply
CL2	Chlorine	Chlorine
CLG	Chlorine Gas	
CLS	Chlorine Solution	
CO2	Carbon Dioxide	Carbon Dioxide
CON		Condensate
CRW	Clarified Discharge Water	
CS	Caustic (Sodium Hydroxide)	Combined Sewer
CWR	Cooling Water Return	Cooling Water Return
CWS	Cooling Water Supply	Cooling Water Supply
D	Drain	Drain
DCW	Domestic Cold Water	Domestic Cold Water
DD	Deacon Effluent (Post UV)	
DDW	Demineralized Water	
DEA	Dilute Acid	
DEC	Dilute Caustic	
DF	DAF Float	
DG		Digester Gas
DGH		Digester Gas, High Pressure
DFR	Diesel Fuel Return	
DFS	Diesel Fuel Supply	

Code	Commodity - Water	Commodity - Wastewater
DHR	Domestic Hot Water Return	Domestic Hot Water Return
DHW	Domestic Hot Water	Domestic Hot Water
DL		Decant Liquor
DP		Dry Polymer
DRA	Drainage (Floors)	
DRN	Drains (Clean Drains)	
DRS	Subdrain	
DS	Deacon Suction	Digester Sludge
DSW	Distilled Water	
DU	Deacon UV (Pre UV)	
EE	Engine Exhaust	
ES	Electric Supply	Electric Supply
EXP	Expansion Tank Equalizer Line	
FC	Ferric Chloride	Ferric Chloride
FE		Final Effluent
FED	Filter Media Education	
FIN	Filter Influent	
FIR	Firewater	
FOA		Foul Air
FOR	Fuel Oil Return	
FOS	Fuel Oil Supply	
FOV	Fuel Oil Vent	
FPW	Fire Protection Water	
FSL		Fermenter Sludge
FSU		Fermenter Supernatant
FSW		Flushing Water
FTR	Filter To Recycle	
FW	Filtered Water	
GE		Grit Effluent
GOX	Gaseous Oxygen	
GR	Glycol Return	Glycol Return
GS	Glycol Supply	Glycol Supply
HCO	Hydraulic Oil	Hydraulic Oil
HFS	Hydrofluosilicic Acid	
HFW		Hot Flushing Water
HP	Hydrogen Peroxide	
HPS	High Pressure Steam	
HR	High Pressure Condensate	

Code	Commodity - Water	Commodity - Wastewater
HST	12% Hypochlorite Solution	
HWS		Hot Water Supply
HWR		Hot Water Return
H2		Hydrogen
HYP	0.8% Hypochlorite Solution	
IAS	Instrument Air Supply	Instrument Air Supply
LCP		Liquid Concentrated Polymer
LDS		Land Drainage Sewer
LGO	Lubricating Oil	Lubricating Oil
LOX	Liquid Oxygen	Liquid Oxygen
LPC	Low Pressure Condensate	
LPS	Low Pressure Steam	Low Pressure Steam
MET		Methanol
ML		Mixed Liquor
MP		Mixed Polymer
MPC	Medium Pressure Condensate	
MPS	Medium Pressure Steam	
MU	Make-Up Water	
N2		Nitrogen
NG	Natural Gas	Natural Gas
O2		Oxygen
OF	Overflow	
OZG	Ozone Off Gas	
OZO	Ozonated Oxygen	
OZW	Ozonated Water	
PRO	Propane	
PC	Pumped Condensate	
PD		Process Drain
PE		Primary Effluent
PEF	Phosphate Feed	
PLD	Dry Polymer	
PLS	Polymer Solution	
PO		Process Overflow
PS		Primary Sludge
PSW	Plant Service Water	
PV		Process Vent
PW	Potable Water	Potable Water
R	Refrigerant	Refrigerant

Code	Commodity - Water	Commodity - Wastewater
RAS		Return Activated Sludge
RD	Roof Drain	
RS		Raw Sewage
RW	Raw Water	
RWL	Raw Water Leader	
SA		Soda Ash
SAM	Sample	
SAN	Sanitary Drainage	
SBS	Sodium Bisulphite	
SC		Scum
SCA	Sulphuric Acid	
SDR	Saturated Recycle Water	
SE		Secondary Effluent
SEA		Service Air
SHC	Sodium Hypochlorite	
SLC		Sludge Cake
SLO	Seal Oil	
SLU	Sludge	
SP	Sprinkler Pipe	
SPD	Sump Pump Discharge	Sump Pump Discharge
SRS		Storm Relief Sewer
STD	Salt Dry	
SUB		DAF Subnatant
SUP	Supernatant	
SW	Seal Water	Seal Water
SWD	Stormwater Drainage	
TBS		Thickened Bottom Sludge
TCE		Treated Centrate
TDW	Tempered Domestic Water	
TO		Thermal Oxidizer
TRW	Treated Water	
TS		Thin Sludge
TW	Tempered Water	
TWAS		Thickened Waste Activated Sludge
VAC	Vacuum	Vacuum
VTA	Vent To Atmosphere	Vent to Atmosphere
W		Water

Code	Commodity - Water	Commodity - Wastewater
WA		Waste Air
WAS		Waste Activated Sludge
WS	Softened Water	
WWS		Wastewater Sewer

5.1.3 Piping Material

Table 5-3 : Piping Material

Designation	Description
AA	Aluminum Alloy
BA	Aluminum Bronze
CG	Galvanized Carbon Steel
CS	Carbon Steel
DI	Ductile Iron
KB	Concrete
PA	ABS (Acrylonitrile-butadiene styrene)
PD	HDPE (High Density Polyethylene)
PP	PP (Polypropylene)
PV	PVC (Polyvinyl Chloride)
SS	Stainless Steel

5.2 Piping Components

5.2.1 Manual Valve Identifier Format – Minor Valves

The identification format for minor manual valves, without instrumentation, is as follows.

FFFF	-	HV	-	P	NNN	S
Facility Code (Optional)	-	Manual Valve Designation	-	Process Area	Equipment Number	Suffix

Where,

FFFF	is the <i>Facility Code</i> , from Appendix A. The <i>Facility Code</i> will typically be implied, and would only be fully written where required.
HV	is the Manual Valve Designation.
P	is the <i>Process Area</i> , which is based on Section 2.3.
NNN	is the <i>Equipment Number</i> of the associated equipment.
S	is the <i>Suffix</i> , a single letter to designate the specific valve.

Notes:

1. *The Equipment Number will typically be the nearest associated equipment. In some cases, Equipment Numbers may be designated for allocation of manual valves.*
2. *Manual valves, check valves, and strainers may utilize common equipment numbers and suffixes. For example, it is acceptable to have a HV-G638A and a CV-G638A.*
3. *Large valves and controlled valves will be identified via the instrumentation standard identified in Section 7.1.*
4. *Typically, significant valves not associated with a specific piece of equipment would be identified as per Section 5.2.2, however the designers discretion may be applied.*

Examples:

- HV-G201A A manual valve in the G process area, associated with pump P-G201.
- HV-M645B A manual valve in the M process area.
- HV-R102A A manual valve in the R process area.

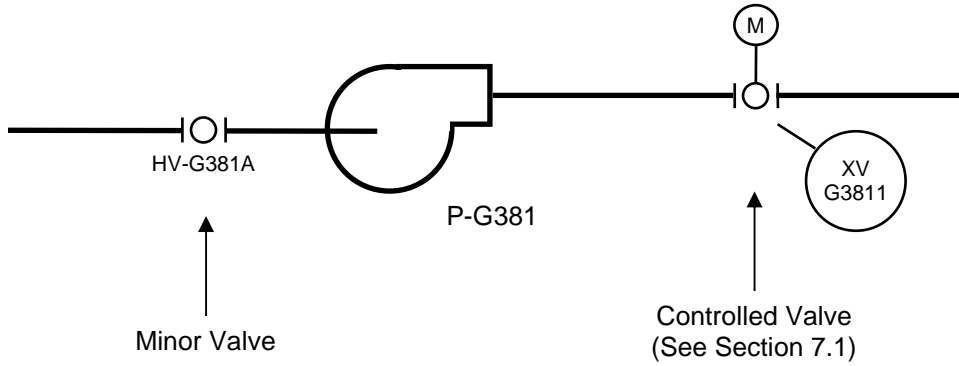

Figure 5-1 : Valve Identification

5.2.2 Manual Valve Identifier Format – Major Valves and Valves with Instrumentation

The identification format for major valves and any manual valve with instrumentation, is based upon the instrumentation standard identified in Section 7.1. The format of the identifier is as follows.

FFFF	-	HV	-	P	NNN	T
Facility Code (Optional)	-	Manual Valve Designation	-	Process Area	Equipment Number	Instrument Number
					Loop Number	

Where,

FFFF	is the <i>Facility Code</i> , from Appendix A. The <i>Facility Code</i> will typically be implied, and would only be fully written where required.
HV	is the Manual Valve Designation.
P	is the <i>Process Area</i> , which is based on Section 2.3.
NNN	is the <i>Equipment Number</i> of the associated equipment. If no equipment is associated, allocate <i>Equipment Numbers</i> specific for the applicable valve.
T	is the <i>Instrument Number</i> , where the number increments from the number 1 through 9. Use of the number 0 should be infrequent, except for special instruments, or those where the instrument ending with 0 is a common instrument that serves other instruments.
NNNT	is the Loop Number, comprised of the <i>Equipment Number</i> together with the <i>Instrument Number</i> .

Notes:

1. *The Equipment Number will typically be the nearest associated equipment. In some cases, Equipment Numbers may be designated for allocation of manual valves.*

Examples:

HV-G2011	A manual valve in the G process area, associated with pump P-G201, and contains open and closed limit switches.
HV-M6451	A manual valve in the M process area, with a position transmitter.
HV-R1022	A manual valve in the R process area, with a limit switch.

5.2.3 Check Valve and Strainer Identifier Format

Check valves and strainers, with no instrumentation, are to be identified as follows:

FFFF	-	EEE	-	P	NNN	S
Facility Code (Optional)	-	Equipment Functional Designation	-	Process Area	Equipment Number	Suffix

Where,

- FFFF is the *Facility Code*, from Appendix A. The *Facility Code* will typically be implied, and would only be fully written where required.
- EEE is the *Equipment Functional Designation*, which is comprised of 2 to 4 characters from Section 4.2. Specifically in this case, CV for Check Valve or STR for strainer.
- P is the *Process Area*, which is based on Section 2.3.
- NNN is the *Equipment Number* of the associated equipment.
- S is the *Suffix*, a single letter to designate the specific valve.

Notes:

1. *The Equipment Number will typically be the nearest associated equipment. In some cases, Equipment Numbers may be designated for allocation of manual valves.*
2. *Manual valves, check valves, and strainers may utilize common equipment numbers and suffixes. For example, it is acceptable to have a HV-G638A and a CV-G638A.*
3. *Controlled valves will be identified via the instrumentation standard identified in Section 7.1.*

Examples:

- CV-G201A A check valve in the G process area, associated with pump P-G201.
- CV-M645B A check valve in the M process area.
- STR-R102A A strainer in the R process area.

5.2.4 Cathodic Protection Components

The identification of cathodic protection system elements is to be developed at a later date.

5.2.5 Sample P&ID

See Figure 5-2 for a sample P&ID segment depicting the identification of manual valves, check valves, and strainers.

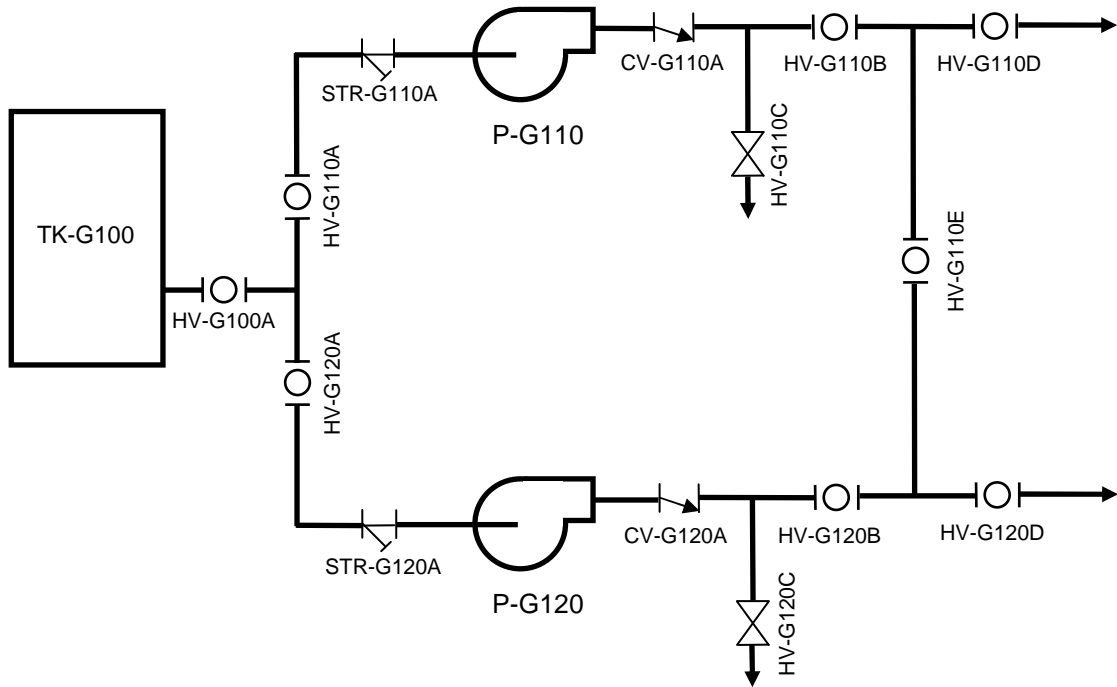

Note: All devices above have an implied facility code prefix of 0102- (or similar).

Figure 5-2 : Sample P&ID – Manual Valve, Strainer, and Check Valve Indication

6 ELECTRICAL

6.1 Equipment Identifier Format

The identification format for electrical equipment is as follows.

FFFF	-	EEEE	-	P	NNN	T	-	S
Facility Code (Optional)	-	Equipment Functional Designation	-	Process Area	Equipment Number	Type Modifier (Optional)	-	Suffix (Optional)

Where,

- FFFF** is the *Facility Code*, from Appendix A. The *Facility Code* will typically be implied, and would only be fully written where required.
- EEEE** is the *Equipment Functional Designation*, which is comprised of 2 to 4 characters from Section 6.2.
- P** is the *Process Area*, which is based on Section 2.3.
- NNN** is the *Equipment Number*. Select numbers consistent with the ranges in Appendix D.
- T** is the *Type Modifier*, an optional field that is utilized to designate essential or UPS powered equipment. See Section 6.3.
- S** is the *Suffix*, an optional numeric or letter code to distinguish between multiple pieces of equipment with a common equipment number. Generally, numbers are utilized for equipment in series, and letters for equipment in parallel.

Examples:

- | | |
|---------------|--|
| 0101-MCC-M001 | A MCC located in the M process area of the NEWPCC facility. |
| DS-G510 | A disconnect switch for pump P-G510. |
| CB-M023-B | The second (alternate) breaker feeding PNL-M023. |
| PNL-S025E | Essential power panelboard located in the S process area. |
| XFMR-H711 | Transformer within a regional water pumping station. |
| MCC-L71 | MCC within a wastewater lift station (Note the two digit equipment number) |

6.2 Electrical Functional Designations

Table 6-1 : Electrical Equipment Functional Designations

Functional Designation	Description	Notes
ATS	Automatic Transfer Switch	
BAT	Battery	
BC	Battery Charger	
BUS	Busway	
C	Cable (Power)	
CAP	Capacitor	Typically individual unit. See PFC.
CB	Circuit Breaker	Includes air, vacuum, SF6, and moulded case circuit breakers
CBUS	Cable Bus	
CON	Contactora	
CP	Control Panel	
CPR	Cathodic Protection Rectifier	
CSTE	Customer Service Termination Equipment	
DP	Distribution Panel	Typically 600V panel, for distributing power to other points of the electrical distribution system.
DS	Disconnect Switch (non-fusible)	
ELB	Emergency Lighting Battery Pack	May have integrated lights.
FAAP	Fire Alarm Annunciator Panel	
FACP	Fire Alarm Control Panel	
FAS	Fire Alarm System	
FDS	Fusible Disconnect Switch	
FU	Fuse	
GEN	Generator	
HCC	Heater Coil Controller	Includes SCR and contactor based controllers.
HF	Harmonic Filter	
JB	Junction Box	
K	Interlocking Key (Kirk Key)	See Section 6.4.5
LC	Lighting Contactor	
LDB	Load Bank	
MCC	Motor Control Centre	
MCP	Motor Circuit Protector	
MCS	Moulded Case Switch	

	Identification Standard	Revision: 00	Page 41 of 120
		Document Code: 510276-0000-40ER-0002	

MMS	Manual Motor Starter	
MS	Motor Starter	
MSP	Motor Starter Panel	
MTR	Motor	
MTS	Manual Transfer Switch	
NGR	Neutral Grounding Resistor	
PB	Pull Box	
PFC	Power Factor Correction Unit	
PM	Power Meter	
PNL	Panelboard	
PS	Power Supply	24VDC power supply
PSP	Power Supply Panel	Panel containing 24VDC power supplies, fire alarm booster power supply.
RCPT	Receptacle	
RCTR	Reactor	Includes VFD line and load reactors.
SCR	Silicon Controlled Rectifier	
SGR	Switchgear	
SPL	Splitter	
SS	Soft Starter	
SW	Switch	
TVSS	Transient Voltage Surge Suppressor	
UPS	Uninterruptible Power Supply	
VFD	Variable Frequency Drive	
XFMR	Transformer	

6.3 Type Modifier

Electrical equipment that is deemed critical to the operation of a facility is typically backed up by one or more generators or some form of uninterruptible power supply. Electrical equipment of this nature is to be identified with a type modifier to provide indication that the equipment is critical in nature.

The following type modifiers will be used on electrical equipment based on the type of backup power system it is supplied by:

Type Modifier	Description
E	Essential – Distribution is deemed to be of higher criticality and is typically backed up by a generator, or at minimum has a transfer switch between multiple sources.
U	Uninterruptible – The distribution equipment is powered by a UPS

Notes:

1. *The Type Modifier is utilized only for essential and uninterruptible power systems.*
2. *The Type Modifier is not to be used on generators or UPS units as these devices are the sources of the backup power supply.*

6.4 Device-Specific Identifier Formats

6.4.1 Receptacle Identifiers

Receptacles are not necessarily required to be uniquely identified, but where they are, the receptacle identification is as follows.

RCPT	-	P	NNN	-	KK	S	-	MM
Receptacle Designation	-	Process Area	Equipment Number of Source Panel	-	Circuit Number	Switched Sub-Circuit (Optional)	-	Incrementing Number (Optional)

Where,

- RCPT** is the receptacle designation.
- P** is the *Process Area*, which is based on Section 2.3.
- NNN** is the *Equipment Number* of the source panel.
- KK** is the *Circuit Number* of the source panel. Where circuit numbers are not applicable, utilize an incrementing number beginning with 1.
- S** is the optional *Switched Sub-Circuit* utilized to identify cables that are switched.
- MM** is an optional *Incrementing Number*, utilized to indicate the specific receptacle powered by the circuit.

Examples:

- RCPT-S022-14-2** A uniquely identified receptacle fed from Circuit 14 of PNL-S022. In this case, it is the 2nd receptacle on the circuit.
- RCPT-M701-1** A uniquely identified receptacle fed from MCC-M701. In this case, it is the only receptacle on the circuit, and as circuit numbers are not typically applied to MCCs, the number 1 is assigned to the circuit number.

6.4.2 Power Cables Associated with Identified Equipment

The identification format for power cables is as follows.

C	-	P	NNN	-	S
Cable Designation	-	Process Area	Equipment Number of Load	-	Suffix (Optional)

Where,

- C** is the Cable Designation. For power cables, the letter C is utilized. For busway, BUS is utilized.
- P** is the *Process Area*, which is based on Section 2.3.
- NNN** is the *Equipment Number* of the load equipment.
- S** is the *Suffix* utilized to identify the specific cable associated with the equipment. The Suffix is not required if a single cable is associated with the equipment. Utilize sequential numbers for cables in series, or for different purposes, and letters for cables in parallel. Utilize the letter T to designate tie connections. Where the load equipment identifier has a suffix in the identifier, set the suffix of the cable to be the suffix of the load identifier plus an additional digit (See receptacle example below)

Notes:

1. *In the event the cable does not serve a specific load, such as a tie cable between two MCCs, select one of the two units of equipment as the prime equipment number for the cable.*
2. *See Section 7.3 for automation cable identification.*

Examples:

- C-G683-1 The feeder for a motor disconnect, DS-G683.
- C-G683-2 The motor cable feeding exhaust fan EF-G683, and fed from disconnect switch DS-G683.
- C-M002 The feeder for MCC-M002
- C-M003-A The normal power feeder to ATS-M003.
- C-M003-B The emergency power feeder to ATS-M003.
- C-M001-T A cable used as a tie between MCC-M001 and DP-M002.
- C-L01 Cable feeding Lift Pump P-L01 in a wastewater lift station.
- C-M710-21 The cable feeding receptacle RCPT-M710-2.

6.4.3 General Purpose Cables – Lighting & Receptacles

The identification format for general purpose cables, for single phase loads, is as follows.

C	-	P	NNN	-	KK	S
Cable Designation	-	Process Area	Equipment Number of Source Panel	-	Circuit Number	Switched Sub-Circuit (Optional)

Where,

- C is the Cable Designation.
- P is the *Process Area*, which is based on Section 2.3.
- NNN is the *Equipment Number* of the source panel.
- KK is the *Circuit Number* of the source panel
- S is the optional *Switched Sub-Circuit* utilized to identify cables that are switched.

Note:

1. *It is expected that three-phase loads will all have equipment numbers assigned.*

Examples:

- C-S022-14 Circuit 14 of PNL-S022.
- C-S022-14A Switched sub-circuit of circuit 14, fed from PNL-S022.

6.4.4 Junction Boxes - Power

The identification format for power junction boxes is as follows.

JB	-	P	NNN	T	-	S
Junction Box Designation	-	Process Area	Equipment Number	Circuit Number	-	Suffix (Optional)

Where,

- JB** is the Junction Box designation.
- P** is the *Process Area*, which is based on Section 2.3.
- NNN** is the *Equipment Number* of the load equipment. If not associated with a specific piece of equipment, use a unique *Equipment Number* in the electrical equipment range, not associated with other equipment, in accordance with the *Equipment Number* ranges in Appendix D.
- T** is the *Type Modifier*, optional to electrical equipment as per Section XX.
- S** is the *Suffix* utilized to identify multiple junction boxes associated with an equipment number.

Examples:

- JB-U421 Junction box associated with pump P-U421.
- JB-C001 Junction box associated with MCC-C001.
- JB-R600 Junction Box associated with numerous pieces of equipment, within a wastewater treatment facility.
- JB-M751 Junction Box associated with numerous pieces of equipment, within a regional water pumping station.

6.4.5 Interlock Keys

The identification format for interlock (Kirk) keys is as follows.

K	NNNN
Interlocking Key Designation	Number

Where,

K is the *Interlocking Key* designation.

NNNN is the *Key Interchange Number*, which is unique for each facility. The *Key Interchange Number* can be from 1 to 4 digits long. For larger facilities, a drawing should be created with an index of Key Interchange Numbers for reference.

Note:

1. *The interlock key identifier will be the same for all interlocks associated with the system. Thus, for a system with four breakers interlocked with four locks and three keys, all four interlocks and keys have the same identifier.*
2. *Process codes are not utilized as key interlocks could span over multiple process areas.*

Example:

K1 First key interlock system for a facility.

K52 52nd key interlock system associated with a facility.

6.4.6 Wire Tags

6.4.6.1 Lighting and Receptacle Circuits - AC

The identification format for lighting and receptacle circuits is as follows.

P	NNN	-	C	S
Process Area	Equipment Number of Source	-	Circuit Number or Neutral Designation	Switched Sub-Circuit (Optional)

Where,

- P** is the *Process Area*, which is based on Section 2.3.
- NNN** is the *Equipment Number* of the source panelboard.
- C** is the *Circuit Number* of the source panelboard, or N for a neutral wire.
- S** is the *Switched Sub-Circuit Designation*, and is an incrementing letter for a conductor that is switched.

Note: The Equipment Functional Designation, typically PNL, is implied to reduce the length of the wire tags.

Examples:

- G701-32 Line (Hot) conductor of circuit 32, associated with PNL-G701.
- W752-N Neutral conductor associated with PNL-W752.
- S702-12B The second switched sub-circuit line (hot) conductor, associated with PNL-S702 circuit 12.

6.4.6.2 DC Power Circuits

DC power circuits, such as from large switchgear DC power supply units require unique identification as follows:

P	NNN	-	C	S	D
Process Area	Equipment Number of Source	-	Circuit Number	Switched Sub-Circuit (Optional)	Power Designation

Where,

- P is the *Process Area*, which is based on Section 2.3.
- NNN is the *Equipment Number* of the source panelboard.
- C is the *Circuit Number* of the source panelboard.
- S is the *Switched Sub-Circuit Designation*, and is an incrementing letter for a conductor that is switched.
- D is the *Power Designation*, which is based on Table 6-2.

Note: The *Equipment Functional Designation*, typically PNL, is implied to reduce the length of the wire tags.

Table 6-2 : DC Power Circuit Wire Tag Power Designations

Power Designation	Description
C	DC Common (0V)
G	Ground
+	DC Positive
-	DC Negative

Note: The *Ground designation* is not typically required, provided that the ground wire is green.

Examples:

- G751-22+ Positive wire of circuit 22, fed from PNL-G751.
- G751-22- Negative wire of circuit 22, fed from PNL-G751.
- G751-22A+ Positive wire of switched circuit 22, fed from PNL-G751.

6.4.6.3 Three Phase Power Wiring

The identification format for three phase power wire tags is as follows.

P	NNN	-	X	H
Process Area	Equipment Number	-	Sequence Number (Optional)	Phase

Where,

- P** is the *Process Area*, which is based on Section 2.3.
- NNN** is the *Equipment Number* of the load equipment. If not associated with a specific piece of equipment, use of *Equipment Number* in the electrical range is preferred, in accordance with the *Equipment Number* ranges in Appendix D.
- X** is an optional *Sequence Number* that is typically a numeric character, utilized when there are multiple power cables associated with an *Equipment Number*.
- H** is the *Phase*, and should be labelled A, B, C, or N.

Three phase power wiring wire tagging is required, except where the conductors are color coding, are in a dedicated cable or conduit, and the routing is obvious.

Examples:

- G681-A** Phase A conductor of a power cable associated with EF-G681. The wire is in common conduit with other power cables.
- W151-2B** Phase B conductor of the second power circuit associated with centrifuge CE-W151.
- No wire tags are needed for the conductors of a pump, fed via a Teck power cable, where the conductors are color coded and the overall cable is identified and labelled.

6.4.6.4 Motor Control Circuits

The identification format for motor control circuits is as follows:

P	NNN	-	WWW	S
Process Area (Optional)	Equipment Number (Optional)	-	Wire Number	Suffix (Optional)

Where,

- P** is the *Process Area*, which is based on Section 2.3. It is not required for wires exclusively within the motor starter.
- NNN** is the *Equipment Number* of the associated equipment. It is not required for wires exclusively within the motor starter.
- WWW** is the *Wire Number*, an incrementing number.
- S** is an optional *Suffix*, and is utilized where it is desired to utilize the same wire number, but the signal has changed.

Notes:

- It is desirable, but not mandatory, that the wire number in a motor starter match the terminal number.*
- It is deemed acceptable to omit the Process Area and Equipment Number for wires exclusively within the motor starter, as it is common industry practice, and MCC manufacturers only typically provide numeric wire numbers.*

Examples:

- 8** Control wire 8 located in the motor starter for AHU-G652, and lands on terminal 8 in the motor starter.
- 8A** Control wire 8A located in the motor starter for AHU-G652, which does not land on a terminal strip.
- G652-8** Control wire 8, located in external field wiring, associated with AHU-G652.

6.4.7 Tie Circuit Breakers

Tie breakers are used to connect electrical buses together. The identification format for electrical equipment is as follows.

FFFF	-	EEEE	-	P	NNN	-	T	-	S
Facility Code (Optional)	-	Equipment Functional Designation	-	Process Area	Equipment Number	-	Tie Designation	-	Suffix (Optional)

Where,

- FFFF** is the *Facility Code*, from Appendix A. The *Facility Code* will typically be implied, and would only be fully written where required.
- EEEE** is the *Equipment Functional Designation*, which is comprised of 2 to 4 characters from Section 6.2. Typically, this is CB for circuit breaker, but could be DS for disconnect switch.
- P** is the *Process Area*, which is based on Section 2.3.
- NNN** is the *Equipment Number*. Select the equipment number of the bus that the tie breaker is more closely associated with.
- T** is the *Tie Designation*, which is always the single letter T.
- S** is the *Suffix*, an optional numeric or letter code to distinguish between multiple tie breakers.

Examples:

- CB-U001-T A tie breaker between SGR-U001 and SGR-U002
- CB-P001-T A tie breaker between SGR-P001 and SGR-P002

Figure 6-1 illustrates a sample electrical single line diagram with tie breakers.

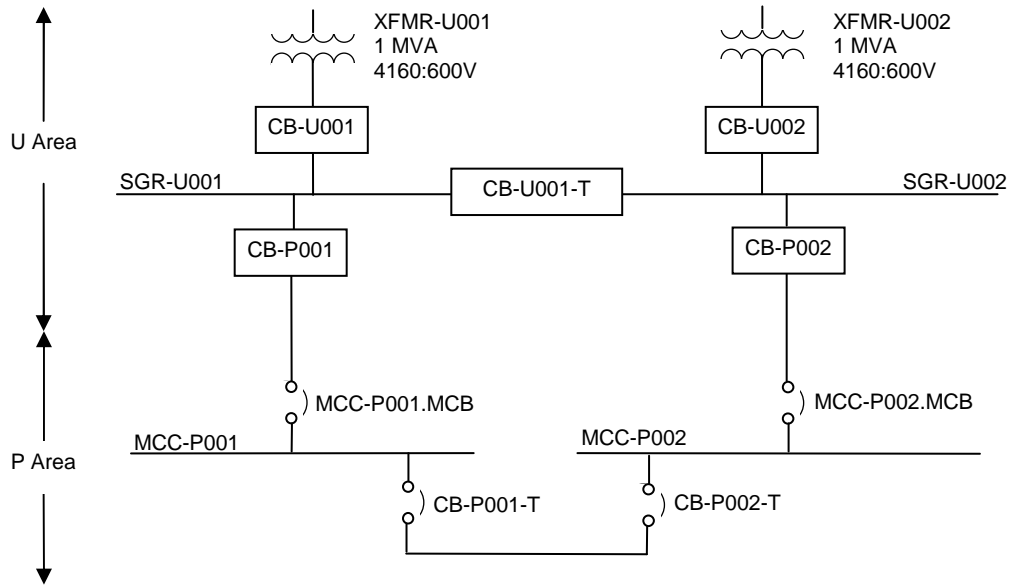

Figure 6-1 : Sample Tie Breaker Identification

6.5 Subcomponents

The following designations are to be utilized for electrical equipment subcomponents. See Section 2.6 for general rules on application of subcomponents. Note that numerous equipment functional designations, shown in Table 6-1, can also be utilized as subcomponent designations, as shown in Table 6-3 below.

Table 6-3 : Electrical Equipment Subcomponents

Subcomponent Designation	Description	Notes
AM	Ammeter	
B	Bus	
CAP	Capacitor	
CON	Contactator	
CPT	Control Power Transformer	
CR	Control Relay	
DS	Disconnect Switch	
F	Fan	
FDS	Fused Disconnect Switch	
FU	Fuse	
M	Motor Contactor	
MCB	Main Circuit Breaker	
MCP	Motor Circuit Protector	
MCS	Moulded Case Switch	
MMC	Motor Management Controller	Also known as intelligent overload.
OL	Overload Relay	
PM	Power Meter	
PS	Power Supply	
R	Reactor	
RLY	Protection Relay	Utilize IEEE Number for Suffix
SCR	Silicone Controlled Rectifier	
TVSS	Transient Voltage Surge Suppressor	
VM	Voltmeter	

Notes:

1. *A motor starter is not typically deemed to be a subcomponent.*

Subcomponent Examples:

- | | |
|---------------|--|
| MS-G261.CAP | A capacitor that is an internal component of MS-G261. If the capacitor were a separate component mounted externally, it would be identified as CAP-G261. |
| MCC-P011.MCB | Integrated Main Circuit Breaker for Motor Control Centre MCC-P011 |
| MCC-P011.TVSS | Transient Voltage Suppressor integrated into MCC-P011 |

A sample single line diagram with subcomponents is shown in Figure 6-2. Note that the full identifier is not written out, provided that the parent identifier is clear from the drawing context.

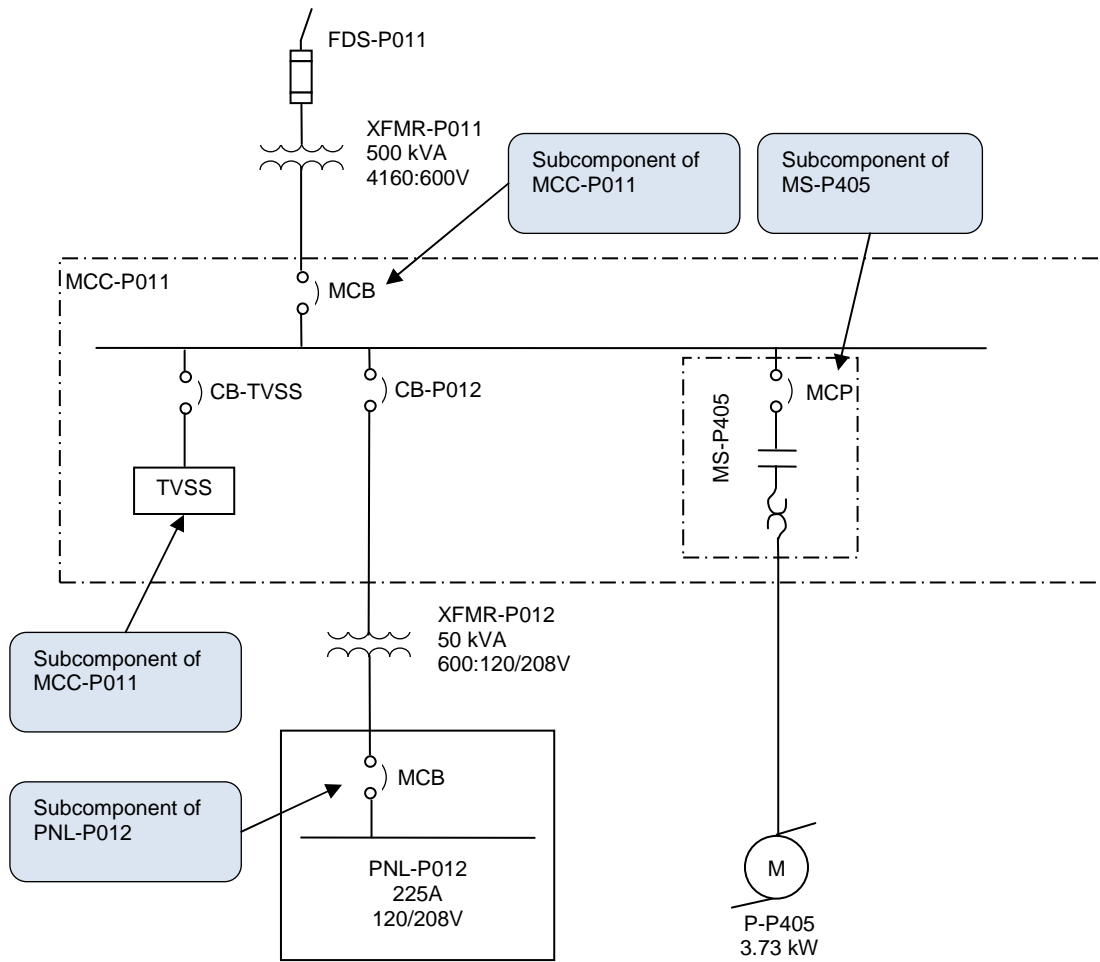

Figure 6-2 : Subcomponents – Electrical Equipment

6.6 Examples

6.6.1 Identification by Load Equipment

An example of a single line diagram, where the identification of a breaker is by the load equipment is shown in Figure 6-3.

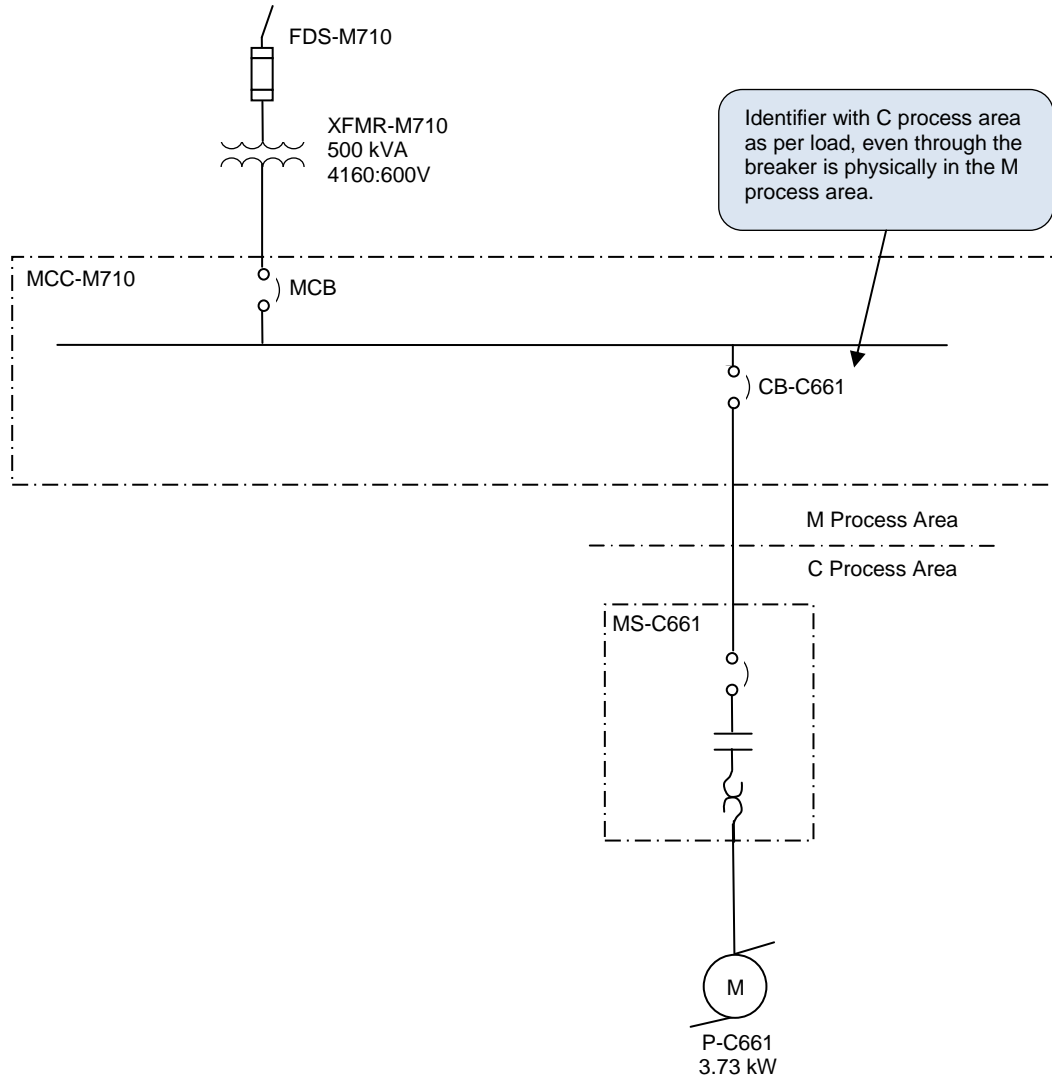

Figure 6-3 : Example Identification by Load Equipment

6.7 Fire Alarm System Devices

6.7.1 Identifier Format

The identification of all fire alarm system components is based upon room numbers rather than equipment numbers. This allows for more rapid recognition of the component location, and avoids utilization of a significant portion of the equipment numbering range for fire alarm system components.

FFFF	-	FAS	-	P	-	L	RR	D	NN
Facility Code (Optional)	-	Fire Alarm Designation	-	Process Area	-	Level	Room Number	Device Designation	Device Number
				From Room Number Designation					

Where,

- FFFF is the *Facility Code*, from Appendix A. The *Facility Code* will typically be implied, and would only be fully written where required.
- FAS is the *Fire Alarm Designation*, which is comprised of the letters FAS.
- P is the *Process Area*, which is based on Section 2.3.
- L is the *Level*, which shall typically be one or two characters, as described in Section 3.2.
- RR is the *Room Number*, which shall be assigned as described in Section 3.2.
- D is the *Device Designation*, which is comprised of a single letter from Section 6.7.2
- NN is the *Device Number*, which uniquely identifies a specific device within a room.

Examples:

- FAS-S-115-D01 The first smoke detector in room 15 on the main level of the Secondary Clarifier process area.
- FAS-M-222-A02 The second horn/strobe in room 22 on the second floor of the M process area.

6.7.2 Fire Alarm Device Designations

Table 6-4 : Fire Alarm Device Designations

Device Designation	Description
A	Annunciation Device (Horn / Strobe)
C	Control Relay Module
D	Detection Device (Heat / Smoke)
E	End-of-line Device
I	Isolation Module
M	Addressable Monitor / Input Module
P	Pullstation
R	Automatic Door Release Device
S	Signal Module

6.7.3 Drawing Format

The format of fire alarm system devices on drawings will typically be as shown in Figure 6-4 below. Note a significant portion of the device identifier is determined via context. Where the context is not clear, use full device identifiers.

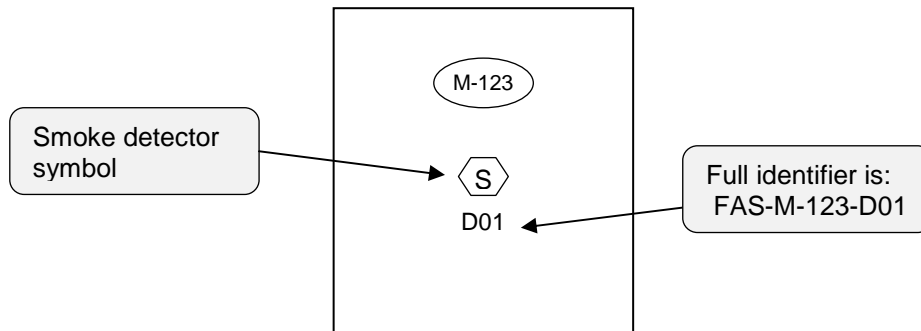

Figure 6-4 : Room Numbering on Drawings – Plan View

6.8 Security Devices

6.8.1 Device Identifier Format

The identification of all security system components is based upon room numbers rather than equipment numbers. This allows for more rapid recognition of the component location, and avoids utilization of a significant portion of the equipment numbering range for security system components.

FFFF	-	SCY	-	P	-	L	RR	D	NN
Facility Code (Optional)	-	Security Designation	-	Process Area	-	Level	Room Number	Device Designation	Device Number
				From Room Number Designation					

Where,

- FFFF is the *Facility Code*, from Appendix A. The *Facility Code* will typically be implied, and would only be fully written where required.
- SCY is the *Security Designation*, which is comprised of the letters SCY.
- P is the *Process Area*, which is based on Section 2.3.
- L is the *Level*, which shall typically be one or two characters, as described in Section 3.2. For outdoor locations, it is recommended that the EX designation be utilized, as described in Section 3.2.
- RR is the *Room Number*, which shall be assigned as described in Section 3.2.
- D is the *Device Designation*, which is comprised of a single letter from Section 0.
- NN is the *Device Number*, which uniquely identifies a specific device within a room.

Examples:

- SCY-S-115-D01 The first door switch in room 15 on the main level of the Secondary Clarifier process area.
- SCY-M-222-A02 The second horn/strobe in room 22 on the second floor of the M process area.
- SCY-S-115-R01 The access card reader outside the door to room 15 on the main level of the Secondary Clarifier process area.
- SCY-A-EX1-VC01 An outdoor video camera in the A process area, exterior zone 1.

6.8.2 Security Device Designations

The security device designations are independent of the Process / Mechanical / Electrical / Automation designations, and may overlap those designations.

Table 6-5 : Security Device Designations – Room Specific

Device Designation	Description	Type Modifiers (See Note 2)
A	Annunciation Device (Horn / Strobe)	H Horn S Strobe
C	Camera	FM Flush Mount PTZ Pan/Tilt/Zoom SM Surface Mount
D	Detector	DS Door Switch GB Glass Break MD Motion Detector
E	End-of-line Device	
I	Isolation Module	
K	Keypad	
M	Addressable Monitor / Input Module	
P	Panic Button	
R	Access Card Reader (See Note 1)	
X	Exit Button	

Note:

1. Access Card Readers will be designated by the room number that access is being granted to.

6.8.3 Security Equipment Designations

Some security equipment is preferable identified as major equipment, and not associated with a specific room. The Security equipment designations are shown in Table 6-6.

Table 6-6 : Security Equipment Designations

Equipment Designation	Description
ACP	Access Control Panel
SCP	Security / Intrusion Alarm Control Panel
SVM	Security Video Monitor
SVR	Security Video Recorder

Note:

1. The above equipment will be identified in a manner consistent with Section 6.1.

6.8.4 Equipment Subcomponent Designations

Table 6-7 : Security Equipment Subcomponent Designations

Equipment Subcomponent Designation	Description
ES	Electric Strike (Subcomponent of Door)
MOD	Input / Output Module
PS	Power Supply
PU	Processing Unit

Note:

1. *The above equipment will be identified in a manner consistent with Section 6.5.*

7 AUTOMATION

7.1 Instrumentation

7.1.1 Instrument Identifier Format

The identification format for instrumentation is as follows.

FFFF	-	XXXX	-	P	NNN	T	-	S
Facility Code (Optional)	-	Instrument Functional Designation	-	Process Area	Equipment Number Loop Number	Instrument Number	-	Suffix

Where,

- FFFF** is the *Facility Code*, from Appendix A. The *Facility Code* will typically be implied, and would only be fully written where required.
- XXXX** is the *Instrument Functional Designation*, which is typically comprised of 2 to 4 characters from Section 7.1.3. Note that five character *Instrument Functional Designations* are possible, but should be quite rare.
- P** is the *Process Area*, which is based on Section 2.3.
- NNN** is the *Equipment Number* of the associated equipment. If no equipment is associated, allocate *Equipment Numbers* specific for the applicable instrumentation. Do not suppress 0's for equipment numbers, as all loop numbers at a site should have the same number of digits in the loop number.
- T** is the *Instrument Number*, where the number increments from the number 0 through 9. Utilize the number 0 for instruments directly associated with motor starters and control. The *Instrument Number* does not increment for every instrument, but rather increments for every instrument loop.
- NNNT** is the Loop Number, comprised of the *Equipment Number* together with the *Instrument Number*. Medium to large facilities will utilize four digit loop numbers, while smaller facilities such as wastewater collections facilities will use three digit loop numbers.
- S** is the *Suffix*, which is used in the cases of multiple instruments on the same or redundant loops. All suffixes are to be numeric.

Examples:

- | | |
|---------------|---|
| XY-G2501 | A solenoid for the valve XV-G250, where the solenoid is remote from the valve. |
| LT-M1011-2 | Redundant Wet Well level transmitter. |
| 0650-PT-M3011 | A pressure transmitter associated with pump M301 at the Hurst Pumping Station. Note that the facility code is optional. |
| HSR-R1100 | A start pushbutton associated with pump P-R110. |

- | | |
|-----------|---|
| TY-B1500 | A temperature relay that takes signals from TT-B1501, TT-B1502, TT-B1503, and TT-B1504 and converts to a Modbus protocol. |
| ZSS-F3212 | A safety switch for CNV-F321. |
| HS-L010 | A start pushbutton for P-L01 at a wastewater lift station. |

7.1.2 Drawing Format

The format for instrumentation on drawings, such as P&IDs, is shown below:

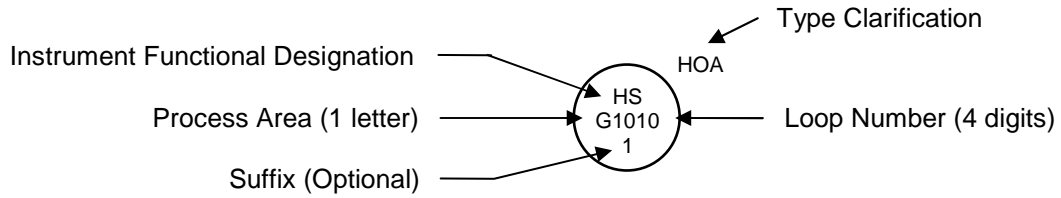

	Identification Standard	Revision: 00	Page 65 of 120
		Document Code: 510276-0000-40ER-0002	

7.1.3 Instrument Functional Designations

An instrument functional designation represents the function of the instrument, and is based upon ISA 5.1. Note that it is possible for an instrument functional designation to be common with a mechanical equipment functional designation, as they will be differentiated by the identifier format. Instrument identifiers will have a four digit loop number, compared with mechanical equipment, which has a three digit equipment number. Thus, even without context, it is possible to differentiate between instruments and other equipment.

Due to the many types of instruments available, a comprehensive list of instrument identifiers is not provided, but rather instrument identifiers are derived from Table 7-1 in a manner that is consistent with ISA 5.1. An instrument functional designation is selected as follows:

- Select the first character from the first column of Table 7-1, based upon the measured or initiating variable of the loop. Optionally, select a second character from the second Modifier column, to indicate a special function associated with the measured or initiating variable. For example, an instrument ultimately part of a safety loop associated with level would have the first two characters designated as LS.
- Select the next character (second or third, depending on whether a second column Modifier is utilized), from either the third or fourth columns. The third column is for Readout or Passive Functions, while the fourth column is for Output Functions.
- Finally, if appropriate, append a letter from the fifth Modifier column, to clarify the function of the instrument. In some cases two characters may be selected from the fifth Modifier column.

A list of common instrument functional designations is provided in Table 7-2.

Table 7-1 : Instrument Functional Designations

	First Letter		Succeeding Letters		
	Measured or Initiating Variable	Modifier	Readout or Passive Function	Output Function	Modifier
A	Analysis		Alarm		
B	Burner, Combustion				
C	Conductivity (1)			Control (2)	Close
D	Density (3)	Difference, Differential			Deviation
E	Voltage		Sensor, Primary Element		
F	Flow, Flow Rate	Ratio			Failure / Fault (14)
G			Glass, Gauge Viewing Device (4)		
H	Hand (Manual)				High
I	Current		Indicate (5)		
J	Power		Scan		
K	Time, Schedule	Time Rate of Change		Control Station	
L	Level		Light (6)		Low
M	Moisture, Humidity (7)				Middle, Intermediate
N					
O	Torque		Orifice, Restriction		Open
P	Pressure		Point (Test Connection)		
Q	Quantity	Integrate, Totalize	Integrate, Totalize		
R	Radiation		Record		Run (8)
S	Speed, Frequency	Safety (9)		Switch	Stop (10)
T	Temperature			Transmitter	
U	Multivariable		Multifunction	Multifunction	
V	Vibration, Mechanical Analysis			Valve, Damper, Louver	
W	Weight, Force		Well, Probe		
X	Unclassified (11)	X Axis	Unclassified	Unclassified	Unclassified
Y	Event, State, or Presence	Y Axis		Auxiliary Device (12)	
Z	Position, Dimension	Z Axis, Safety Instrumented System (13)		Driver, Actuator, Unclassified Final Control Element	

	Identification Standard	Revision: 00	Page 67 of 120
		Document Code: 510276-0000-40ER-0002	

Notes for Instrument Functional Designations:

1. *The use of the letter C for conductivity is a City specific user assignment.*
2. *Utilize the output designation C for an automatic device or function that receives an input signal and generates a variable output signal that is used to modulate or switch a valve or otherwise control a final drive element. Do not utilize the C designation for a control valve, unless the valve independently measures the process variable and determines the appropriate valve position. Thus, the use of TCV, FCV, or LCV is not common. The use of PCV is more common, for pressure regulators.*
3. *The use of the letter D for density is a City specific user assignment.*
4. *Utilize the letter G for all pressure gauges (i.e. PG), thermometers (i.e. TG), and viewing glasses (e.g. LG).*
5. *The Readout/Passive Function letter I is to be utilized for analog or digital readouts of a measurement or input signal. Do not utilize for indication of discrete on/off signals.*
6. *The Readout/Passive Function letter L is to be utilized for indication of discrete on/off states. Do not utilize for alarms, which should utilize the A designation.*
7. *It is recommended to utilize the initial letter M as a designation for moisture, which is common industry practice. The City has historically applied the letter M for Motor, however this use is not consistent with ISA 5.1 and it is recommended that this use be discontinued.*
8. *Utilize the modifier R to designate a Run or Start modifier. Note that this designation was added in the 2009 revision to ISA-5.1.*
9. *Utilize the letter S as a modifier for safety components not part of a Safety Instrumented System (SIS). The letter S modifier is to be utilized for self-actuated emergency protective primary and final control elements only when used in conjunction with Measured/Initiating Variables flow [F], pressure [P] or temperature [T]. An example is a PSV for a pressure safety relief valve utilized to protect against emergency conditions that are not expected to normally occur.*
10. *Utilize the modifier S to designate a Stop modifier. Note that this designation was added in the 2009 revision to ISA-5.1.*
11. *The letter X is to be defined at the time of use, and may be used for multiple definitions where no other letter is applicable. The letter X is commonly applied to controlled on-off valves, where the initiating variable is not clearly defined.*
12. *The use of output function Y is to be utilized for a device that connects, disconnects, transfers, computes, and/or converts air, electronic, electric, or hydraulic signals or circuits. Use for a current to pressure signal converter would be appropriate.*
13. *Variable modifier Z is to be utilized for all components of a safety instrumented system (SIS). An example is a SIS system pressure transmitter, designated PZT.*
14. *The use of the letter F as a Modifier to represent Failure or Fault is an extension to ISA-5.1.*

Table 7-2 : Common Instrument Functional Designations

Designation	Direct Translation	Example
AA	Analysis Alarm	Gas detection horn / strobe
AAH	Analysis High Alarm	H ₂ S gas detection high level alarm
AT	Analysis Transmitter	H ₂ S gas detection transmitter
DT	Density Transmitter	Density transmitter without local indication
EG	Voltage Viewing Device	Capacitive voltage indicator
EL	Voltage Light	Pilot light indicating voltage is present
EI	Voltage Indicator	Voltage meter with numeric scale, or digital meter
ES	Voltage Switch	General voltage relay
ESL	Voltage Switch - Low	Undervoltage relay
ET	Voltage Transmitter	Voltage transducer
FAL	Flow Alarm - Low	Pilot light indicating low flow
FCV	Flow Control Valve	Integrated valve to limit the flow below a setpoint. The valve is not externally controlled.
FE	Flow Element	Magnetic flowtube, orifice plate
FIT	Flow Indicating Transmitter	Magnetic flowmeter transmitter with local indication
FT	Flow Transmitter	Magnetic flowmeter transmitter without local indication
FV	Flow Valve	Butterfly valve with positioner, modulated by a signal initiated by a flowmeter.
HS	Hand Switch	Hand/Off/Remote switch
HSR	Hand Switch – Start/Run	Start pushbutton
HSS	Hand Switch - Stop	Stop pushbutton, including emergency stop pushbuttons, unless associated with a Safety Instrumented System.
JIT	Power Indicating Transmitter	Power meter
KS	Time Switch	Timing relay
LSH	Level Switch - High	Sump pit high level switch
LSL	Level Switch - Low	Sump pit low level switch
LE	Level Sensor	Ultrasonic level transducer
LIT	Level Indicating Transmitter	Ultrasonic level transmitter with local indication
LT	Level Transmitter	Ultrasonic level transmitter without local indication
ME	Moisture Sensor	Moisture sensor
OSH	Torque Switch - High	Torque limit switch
PG	Pressure Gauge	Mechanical pressure gauge local to piping
PI	Pressure Indicator	Pressure display remote from piping, with scale.

Designation	Direct Translation	Example
PSL	Pressure Switch - Low	Low pressure switch on air receiving tank
PSH	Pressure Switch - High	High pressure switch on air receiving tank
PT	Pressure Transmitter	Analog pressure transmitter
ST	Speed Transmitter	Speed pulse encoder
TE	Temperature Element	Thermocouple or RTD temperature sensor
TG	Temperature Gauge	Local temperature gauge
TSH	Temperature Switch - High	High temperature switch
TI	Temperature Indicator	Digital temperature indicator or local analog indicator based upon a capillary tube
TSL	Temperature Switch - Low	Low temperature switch
TT	Temperature Transmitter	Analog temperature transmitter
VE	Vibration Sensor	Vibration sensor
VIT	Vibration Indicating Transmitter	Vibration transmitter with local indication
XV	Unclassified Valve	Typically use for on/off valves
ZSC	Position - Closed	Valve closed limit switch
ZSO	Position - Open	Valve opened limit switch
ZT	Position Transmitter	Linear position transmitter

7.1.4 Type Clarification

The instrument *Type Clarification* is an optional additional field on the outside of the instrument tag bubble, as shown in Section 7.1.2. The *Type Clarification* is not part of the identifier, but rather additional information that is useful to the P&ID reader. The site P&ID legend sheet should contain all type clarifications utilized at the site. Examples are provided in Table 7-3 on the next page, and additional examples are provided in Table 5.2.2 of ISA 5.1.

Table 7-3 : Type Clarification Examples

Functional Identifier	Type Clarification	Description
AIT	CO	Carbon monoxide transmitter
AIT	COMB	Combustible gas transmitter
AIT	H2S	Hydrogen sulphide transmitter
AIT	O2	Oxygen transmitter
FE	COR	Coriolis flow element
FE	MAG	Magnetic flow element
FE	US	Ultrasonic flow element
HS	H/O/A	Hand / Off / Auto Switch
HS	H/O/R	Hand / Off / Remote Switch
HS	O/A	Off / Auto Switch
HS	O/O	Off / On Switch
HS	RST	Reset
HSS	EMG	Emergency Stop Switch
LE	CAP	Capacitance level element
LE/LT	DP	Differential pressure level element
LE	RAD	Radar level element
LE/LT	SDP	Submersible differential pressure
LE	US	Ultrasonic level element
PT	ABS	Absolute pressure transmitter
PT	VAC	Vacuum pressure transmitter
TT	TC	Thermocouple temperature transmitter
TT	RTD	Resistance temperature transmitter

	Identification Standard	Revision: 00	Page 71 of 120
		Document Code: 510276-0000-40ER-0002	

7.1.5 Valve Identification

Historically there has been some confusion regarding valve identification, and the purpose of this section is to clarify the appropriate functional identification for valves, as per ISA 5.1.

7.1.5.1 Manual Valves

All manual valves are to be identified as HV, as per Sections 5.2.1 and 5.2.2.

Valves that have an actuator, but are always operator controlled remotely via a PLC, DCS, or some other control system are to be identified as per Sections 7.1.5.4 and 7.1.5.5.

7.1.5.2 Actuated Valves with Internal Controller

A self actuating valve that has a process signal as an input is a *control valve*, where the initial letter is the measured process variable. Examples are as follows:

- | | |
|-----|--|
| FCV | Flow Control Valve – a valve with an internal mechanism or logic that measures flow and controls it to some setpoint. This could either be a Foundation Fieldbus Controlled valve with an integral PID controller, or a mechanical flow regulator. A valve that controls flow, but receives a position signal from an external controller is not a FCV (as per ISA 5.1). |
| PCV | Pressure Control Valve – a valve with an internal mechanism or logic that measures pressure and controls it to some setpoint. This could either be a Foundation Fieldbus Controlled valve with an integral PID controller, or a pressure regulator. A valve that controls pressure, but receives a position signal from an external controller is not a PCV (as per ISA 5.1). |

7.1.5.3 Actuated Valves with External Controller

A valve with an actuator that is positioned by an external signal is a *control valve*, where the initial letter is the measured process variable. Examples are as follows:

- | | |
|----|---|
| FV | Flow Valve – a valve with or without a positioner, that is positioned by an external controller based upon a measured or initiating flow signal. The signal from the external controller to the valve is a position command signal. Note that many valves control the flow within a pipe, but not all such valves are necessarily <i>Flow Valves</i> , as per ISA 5.1. Only valves that have a control loop with flow as the initiating variable are <i>Flow Valves</i> . |
| LV | Level Valve – a valve with or without a positioner, that is positioned by an external controller, that uses level as its initiating or measured variable. The signal from the external controller to the valve is a position signal. Note that while the valve may control the flow within the pipe, it is not a <i>Flow Valve</i> if the initiating variable is <i>Level</i> . |
| PV | Pressure Valve – a valve with or without a positioner, which is positioned by an external controller based upon level as its initiating or measured variable. The signal from the external controller to the valve is a position command signal. Note that while the valve may control the flow within the pipe, it is not a <i>Flow Valve</i> if the initiating variable is <i>Pressure</i> . |
| UV | Multivariable Valve – a valve with or without a positioner, that is positioned by an external controller based upon multiple variables as input into the controller. The signal from the external controller to the valve is a position command signal. Note that while the valve may control the flow within the pipe, it is not a <i>Flow Valve</i> if there are multiple initiating variables. |

	Identification Standard	Revision: 00	Page 72 of 120
		Document Code: 510276-0000-40ER-0002	

7.1.5.4 Actuated Valves (Modulated) with Operator Control

A valve with an actuator that is positioned by a signal controlled by a human operator is to be identified by the major initiating variable that the operator would reference. Note that this definition is only marginally consistent with ISA 5.1, as a direct interpretation of ISA 5.1 would likely result in a HV – *Hand Valve* identification. Discussions with City personnel have indicated that it is not desirable to identify these valves as *Hand Valves*, which in their opinion, should be reserved for manual valves. Not that this identification only applies to modulating valves and not to on/off valves.

Examples:

FV-T4061 An valve actuated from a signal, that is controlled by an operator via an HMI interface. The operator periodically monitors a flow rate in the process and manually adjusts the position setpoint for the valve.

7.1.5.5 Actuated On/Off Valves

An on/off valve with an actuator that is controlled by an external controller is to typically be identified as an XV, or *Undefined Valve*. ISA 5.1 is not clear on how to address the identification of on/off valves, and while YV (State Valve) or UV (Multivariable Valve) are potential identifiers, common industry practice is that XV is commonly utilized. Discretion must be applied, and while there are cases where on/off valves with other initial variables would be appropriate, it is recommended that all on/off valves, where the initiating variable is not clear, be identified as XV. On/Off valves with remote operator control are also to be identified as XV, unless the initiating variable that the operator is responding to is absolutely clear.

Examples:

XV-G6011 An on/off intake damper on an air handler, AHU-G601, which closes when the air handler is not in operation.

XV-M1511 An on/off discharge valve on a pump, P-M151, which closes when the pump is not in operation.

LV-S2032 An on/off valve that shuts off when the level in tank TK-S203 exceeds a setpoint. This is an example where the initiating variable is clearly level, and the valve should be identified as such.

XV-R325 An on/off valve that interconnects two forcemains in a wastewater forcemain application, that is actuated by operator control. Note that the loop number is only three digits as this is a *Collections* application.

7.2 Automation Equipment

7.2.1 Identifier Format

The identification format for automation equipment, other than instrumentation, is as follows.

FFFF	-	EEEE	-	P	NNNN	-	S
Facility Code (Optional)	-	Equipment Functional Designation	-	Process Area	Equipment Number	-	Suffix (Optional)

Where,

- FFFF** is the *Facility Code*, from Appendix A. The *Facility Code* will typically be implied, and would only be fully written where required.
- EEEE** is the *Equipment Functional Designation*, which is comprised of 2 to 4 characters from Section 7.2.2.
- P** is the *Process Area*, which is based on Section 2.3.
- NNNN** is the *Equipment Number*. Select numbers consistent with the ranges in Appendix D.
- S** is the *Suffix*, an optional numeric or letter code to distinguish between multiple pieces of equipment with a common equipment number. Generally, numbers are utilized for equipment in series, and letters for equipment in parallel.

Examples:

- 0101-PLC-G801 A PLC located in the Grit process area of the NEWPCC facility.
- PLC-G110 A PLC dedicated to pump P-G110.
- RIO-G110-1 Remote I/O associated with PLC-G110
- JBA-L52 An automation junction box in a Collections Facility.

7.2.2 Functional Designations

Table 7-4 : Automation Equipment Functional Designations

Functional Designation	Description	Notes
ADP	Automation Device Panel	
CA	Cable (Automation)	
CP	Control Panel	
CS	Computer Server	
CW	Computer Workstation - General	
CWD	Computer Workstation - Development	
CWO	Computer Workstation - Operator	
DCS	Distributed Control System	
FDP	Field Device Panel	Use for new installations should not be common.
GDC	Gas Detection Controller	
HMI	Standalone Human Machine Interface (HMI) Terminal	e.g. local touchscreens
JBA	Junction Box (Automation)	
LCP	Local Control Panel	
PLC	Programmable Logic Controller	
PRN	Printer	
RIO	Remote I/O	
RTU	Remote Terminal Unit	

Notes:

1. *Avoid overlap of Automation Equipment Functional Designations with Electrical, Mechanical, or Process Functional Designations.*

 Winnipeg	Identification Standard	Revision: 00	Page 75 of 120
		Document Code: 510276-0000-40ER-0002	

7.2.3 IT Equipment Designations

Equipment within the domain of the City's Information Technology division may utilize a City IT specific identifier. Where this IT identifier is utilized, it is recommended that it is utilized in parallel to the identifiers in this standard. The rationale for this is as follows:

- The IT identifiers are created and tracked by a separate division within the City and are not managed by the same groups responsible for the remainder of the assets of the Water and Waste department.
- The IT identifiers are not consistent with this standard.
- The IT identifiers are applied in a "serial number" style to a specific piece of hardware, and not utilized as an asset identifier, as per the equipment within this standard. For example, if a computer is replaced, the IT identifier would change. However, for computers shown on automation drawings, use of the IT identifier in the automation domain would require that all relevant drawings with identifiers be updated.
- It is recommended to segregate the IT and Automation domains as much as possible.

7.3 Automation Cables

7.3.1 Instrumentation Cables

The identification format for automation cables is as follows. Note that the identification of power cables is discussed in Sections 6.4.2 and 6.4.3.

CA	-	P	NNNT	-	S
Cable Designation	-	Process Area	Loop Number of Instrumentation	-	Suffix (Optional)

Where,

- CA is the *Cable Designation*, which for automation cables is comprised of the letters CA.
- P is the *Process Area*, which is based on Section 2.3.
- NNNT is the *Loop Number* of the associated instrument. Where the cable connects two instrumentation devices with different loop numbers, identify the cable by the device that provides the signal.
- S is the *Suffix* utilized to identify the specific cable associated with the loop. The Suffix is not required if a single cable is associated with the instrument loop. Utilize sequential numbers for cables in series, or for different purposes, and letters for cables in parallel.

Examples:

- CA-G6831 A cable from FSL-G6831 to a control panel.
- CA-S5011-1 A signal cable from a flowmeter to a control panel mounted instrument, FC-S5011.

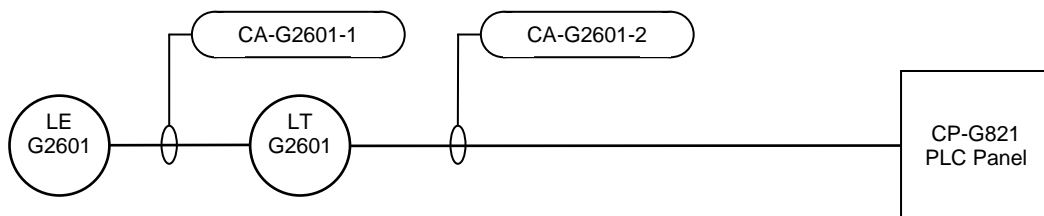

Figure 7-1: Instrument Cable Identification Example – Level Transmitter

7.3.2 Cables Associated with Identified Equipment

The identification format for automation cables is as follows.

CA	-	P	NNN	-	S
Cable Designation	-	Process Area	Equipment Number of Associated Equipment	-	Suffix (Optional)

Where,

- CA is the *Cable Designation*, which for automation cables is comprised of the letters CA.
- P is the *Process Area*, which is based on Section 2.3.
- NNN is the *Equipment Number* of the associated equipment. Where the cable connects two pieces of equipment, identify by the downstream, or serviced piece of equipment.
- S is the *Suffix* utilized to identify the specific cable associated with the equipment. The Suffix is not required if a single cable is associated with the equipment. Utilize sequential numbers for cables in series, or for different purposes, and letters for cables in parallel.

Note: In some cases, a cable could be considered either associated with instrumentation (4 digit loop number as per Section 7.3.1) or equipment (3 digit equipment number as per this section). It is left up to the designer to select the most appropriate cable identifier.

Examples:

- CA-G683-1 A 120 VAC control cable for pump P-G683.
- CA-F723 A control cable for UPS-F723
- CA-P711 A cable with a signal from a breaker status in PNL-P711.



Figure 7-2: Instrument Cable Identification Example – Identified Equipment

7.4 Sample P&ID

A sample pump P&ID is provided below to illustrate typical conventions for identifying instrumentation.

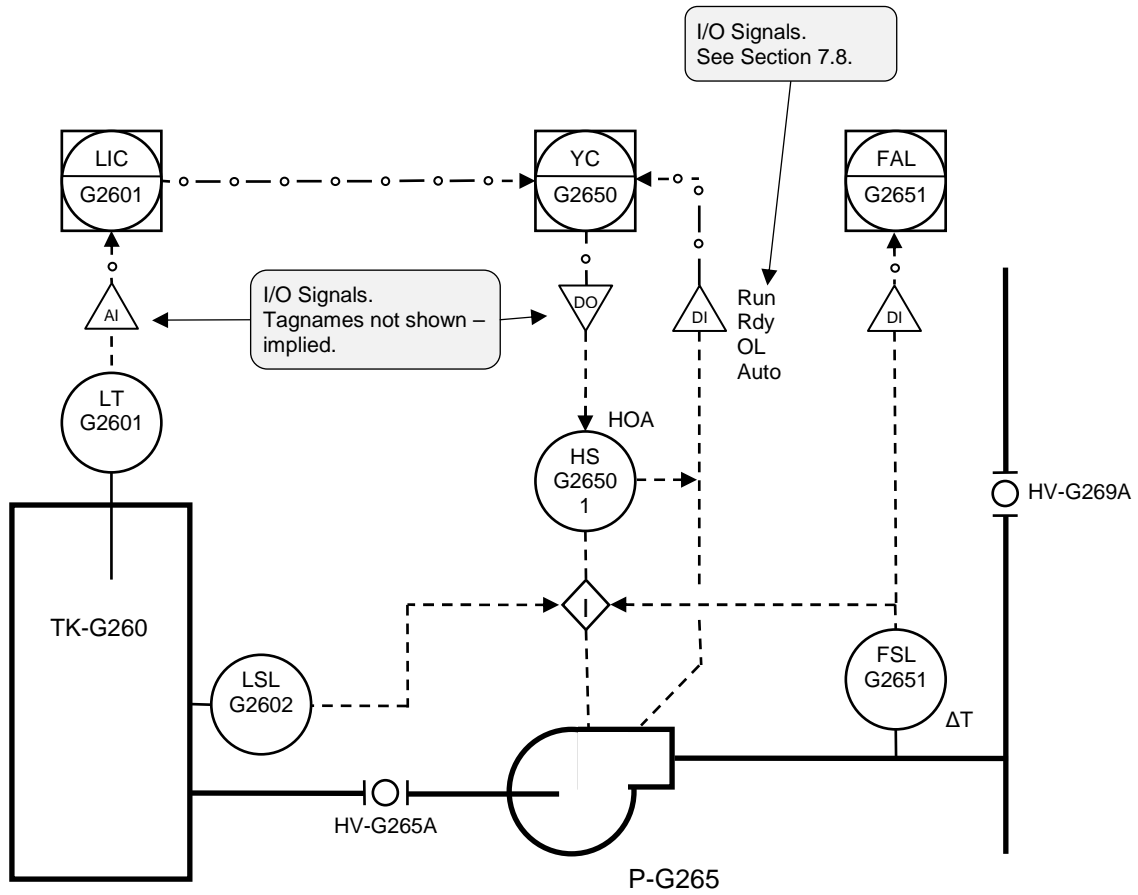

Figure 7-3: Sample Pump P&ID

7.5 Wire Tags

7.5.1 Power Circuits within Control Panels

Power circuits within control panels only require unique identification within the control panel. Where power circuits extend outside the panel, they will typically be based upon the wire tagging scheme identified in Sections 7.5.2 and 7.5.3.

The identification format for power circuit wire tags within control panels is as follows.

D	W
Power Designation	Wire Number

Where,

- D is the *Power Designation*, which is based upon Table 7-5.
W is the *Wire Number*, an incrementing number.

Table 7-5 : Wire Tag Power Designations

Power Designation	Description
C	DC Common (0V)
G	Ground
L	AC Power (Hot)
N	AC Neutral
P	DC Positive
NEG	DC Negative (not grounded)

Note: The Ground designation is not typically required, provided that the ground wire is green.

Examples:

- L1 Main 120VAC circuit within a control panel.
L11 120VAC sub-circuit, after fuse F11.
N1 AC Neutral associated with circuit L1.
P22 24VDC circuit
C1 24VDC common wire (0V)

7.5.2 Control Circuits

The identification format for automation control circuits is as follows:

P	NNN	T	-	W	S
Process Area	Equipment Number	Instrument Number	-	Wire Number	Suffix (Optional)
	Loop Number				

Where,

- P** is the *Process Area*, which is based on Section 2.3.
- NNN** is the *Equipment Number* of the associated equipment. If no equipment is associated, allocate *Equipment Numbers* specific for the applicable instrumentation.
- T** is the *Instrument Number*, where the number increments from the number 1 through 9. Use of the number 0 should be infrequent, except for special instruments, or those where the instrument ending with 0 is a common instrument that serves other instruments.
- NNNT** is the *Loop Number*, comprised of the *Equipment Number* together with the *Instrument Number*.
- W** is the *Wire Number*, which is typically an incrementing number. For power wires the *Wire Number* shall be based on Table 7-5.
- S** is an optional *Suffix*, and is utilized where it is desired to utilize the same wire number, but the signal has changed.

Notes:

1. *It is not required that the Wire Number match the control panel terminal number.*
2. *See Section 6.4.6.4 regarding wire numbering for motor control circuits.*

Examples:

- G6521-11 Control wire 11 associated with TSH-G6521.
- G6521-11A Control wire 11A associated with TSH-G6521.
- G6522-P 24VDC Power wire for FT-G6522.
- G6522-C 24VDC Common wire for FT-G6522.

7.5.3 Analog Signal Circuits - Instruments

The identification format for analog signal circuits associated with instruments is as follows:

P	NNN	T	-	W	A
Process Area	Equipment Number	Instrument Number	-	Wire Number (Optional)	Analog Designation
	Loop Number				

Where,

- P** is the *Process Area*, which is based on Section 2.3.
- NNNT** is the Loop Number, comprised of the *Equipment Number* together with the *Instrument Number*.
- W** is the *Wire Number*, an incrementing number. The wire number may optionally be omitted for two wire control.
- A** is the Analog Designation, which is typically either “+” or “-“. For power wires the designation shall be based on Table 7-5.

Notes:

1. *It is not required that the Wire Number match the control panel terminal number.*
2. *For two-wire signals, use “+” and “-“ designations. Do not utilize a power designation “-P” for two wire signals.*

Examples:

- G6523+ Signal wire + associated with TT-G6523.
- G6523- Signal wire - associated with TT-G6523.
- M4215-1+ Signal wire 1+ associated with FT-M4215
- M4215-P 24VDC power wire associated with FT-M4215 (Four wire signal).

7.5.4 I/O Wiring

I/O wiring within a control panel is designated by the I/O address rather than the connected instrument. This allows for a more straightforward control panel layout, and avoids relabeling internal panel wiring upon reallocation of I/O. The identification format for I/O wiring in a control panel is as follows:

DD	R	.	M	.	N	A
I/O Designation	Rack Number (Optional)		Module Number (Optional)		I/O Number	Analog Designation (Optional)

Where,

- DD** is the *I/O Designation*, which is based on Table.
- R** is the *Rack Number*, which is typically one or two digits. A Rack Number is not applicable to all I/O systems.
- W** is the *Module Number*, which is typically one or two digits. A *Module Number* is not applicable to all I/O systems.
- A** is the Analog Designation, if applicable, and typically is either “+” or “-“.

Table 7-6 : I/O Designations

Power Designation	Description
AI	Analog Input
AQ	Analog Output
I	Discrete Input (AC or DC)
Q	Discrete Output (AC or DC)

Notes:

- The I/O Wiring Designation is to be utilized within a control panel only. Utilize wire designations based upon Sections 7.5.2 and 7.5.3 for wiring outside the control panel.*
- It is acceptable for a wire on one side of a terminal to be designated by an I/O designation and to have an alternate identifier for the wire on the other side of the terminal.*

Examples:

- AI1.0.1+ Analog input + wire associated with rack 1, module 0, point 1.
- AQ5.3- Analog output – wire associated with module 5, point 3. The rack number is not applicable.
- I52 Discrete input 52. The rack number and module number are not applicable.
- I5.3.31 Discrete input associated with rack 5, module 3, point 31.
- Q2.1.5 Discrete output associated with rack 2, module 1, point 5.

7.6 Subcomponents

As described in Section 2.6, devices that are an inherent component of a larger unit of equipment or instrumentation are designated as subcomponents. With a strict implementation of ISA 5.1, these subcomponents would potentially be given full identifiers. However, in assigning full identifiers for these signals, the relationship between the subcomponent and its parent piece of equipment is not always clear. Additionally, more identifiers are used as a result of having to assign an identifier to each subcomponent. A good example of instrumentation subcomponents is a valve with limit switches. The limit switches are typically deemed to be a subcomponent of the valve.

As described in Section 2.6, subcomponents can be identified by extending the containing equipment name with a suffix. The parent equipment identifier and suffix are to be separated by a period. This system creates a hierarchy, allowing for rapid identification of subcomponents and reduces programming efforts when integrating these signals into an automation system.

A good example for a mechanical piece of equipment that contains subcomponents is a valve actuator with integrated open and closed limit switches. The limit switches would not typically be labelled separately in the field, as there is no specific discrete equipment to attach the label to, other than the valve actuator as a whole. The suffix would be based upon the subcomponent's functional identification. For example:

A P&ID example with a subcomponent is shown in Figure 7-4. Note that the subcomponents of the valve are the limit switches, identified as follows.

XV-G381.ZSO The open limit switch of the valve XV-G381

XV-G381.ZSC The closed limit switch of the valve XV-G381

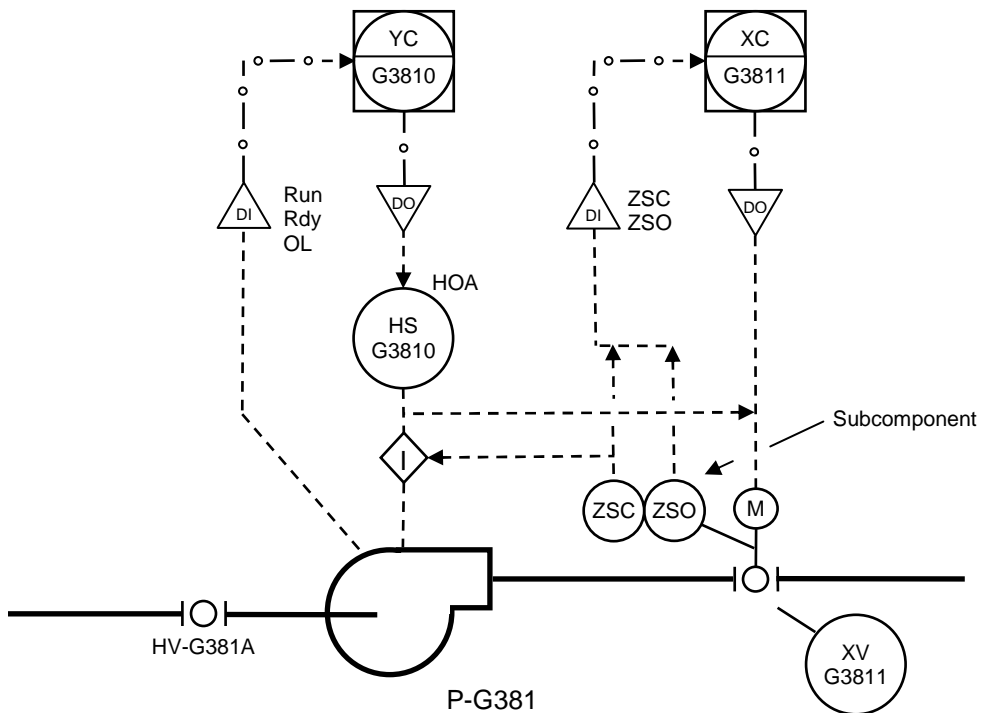

Figure 7-4 : Subcomponents – Mechanical and Process Equipment

7.7 Software Configuration File Naming

Where software to configure automation equipment does not include integral version management, software configuration file names shall be composed as follows.

FFFF		E*		YYYY	MM	DD	-	X
Facility Code (Optional)	-	Equipment Identifier	-	Year	Month	Day	-	Revision Modifier (Optional)
						Date		

Where,

- FFFF is the *Facility Code*, from Appendix A. The *Facility Code* will typically be implied, and would only be included in the filename where required.
- E* is the unique *Equipment Identifier*, as identified by other sections of this document.
- YYYYMMDD is the date of the last edit.
- X is the *Revision Modifier*, which a letter beginning with A, B, C.... used to indicate intra-day revisions.

Examples:

- | | |
|---------------------|--|
| PLC-G250-20120819 | A PLC program for PLC-G250 last edited on August 19, 2012. |
| LT-M1011-20120501-B | A configuration file for level transmitter LT-M1011, dated May 1, 2012, second revision. |
| NSW-C901-20121231 | A network switch configuration file dated December 31, 2012. |

7.8 I/O and Signal Tags

7.8.1 Discrete Input Signals

Identification of discrete input signals (I/O) will be as follows:

E*	.	F	-	S
Source Equipment / Instrument Identifier	.	Functional Signal Designation	-	Suffix (Optional)

Where,

- E* is the *Source Equipment / Instrument Identifier*, based upon other parts of this document.
- F is the *Functional Signal Designation*, which represents the type of discrete signal. The *Functional Signal Designation* shall utilize ISA-5.1 style naming convention where applicable, but if not applicable, shall be based on Table 7-7.
- S is the optional *Suffix*, which is a number utilized to differentiate between multiple similar signals.

Examples:

- HSS-G1050 Stop pushbutton signal from HSS-G1050, which is associated with pump P-G105. Note that no Functional Signal Designation is required, as only a single, unambiguous signal is provided from the switch.
- HS-G1050.Rem The switch in *Remote* signal from the *Hand-Off-Remote* switch HS-G105, which is associated with pump P-G105. A Functional Signal Designation is required to clarify the indicated specific switch position.
- VFD-G101.Fl_t VFD fault signal for pump P-G101. As the fault is associated with the VFD, the VFD is deemed to be the *Source Equipment / Instrument Identifier*.
- AHU-M602.Run Running signal from AHU-M602 motor starter. As the air handling unit is deemed to be the functional source of the running signal, it is deemed to be the *Source Equipment / Instrument Identifier*.
- FT-S6021.Fl_t Fault signal associated with flow transmitter FT-S6021.
- XV-S3810.ZSC Closed limit switch signal from valve XV-S3810.
- XV-S3810.HS_Auto Hand switch in auto signal from valve XV-S3810. This signal name would be appropriate if the valve actuator has an integrated *hand-off-auto* switch. In the event that the *hand-off-auto* switch was independent of the valve actuator, it would have an instrument identifier, and the *Source Equipment / Instrument Identifier* would be based on the switch identifier.

TSH-G1051 A high temperature signal from TSH-G1051.
TSH-G1052-1 A high temperature signal from TSH-G1052-1.
TY-G1053.TSH A high temperature output signal from a temperature relay.

Table 7-7 : Discrete Input Functional Signal Designations – Non ISA

Signal	Description
.Auto	Hand Switch Auto Position
.Byp	Hand Switch Bypass Position
.Flt	Faulted
.HS_*	Signal from Hand Switch Integrated into Equipment. See Note 4.
.Loc	Hand Switch Local Position
.Man	Hand Switch Manual Position
.Occ	Hand Switch Occupied Position
.Off	Hand Switch Off Position
.Rdy	VFD / Motor Starter Ready
.Rem	Hand Switch Remote Position
.Rst	Hand Switch Reset Pushbutton
.Run	Motor Running
.Start	Hand Switch Start Pushbutton
.Stop	Hand Switch Start Pushbutton

Notes:

1. *The above list does not indicate ISA 5-1 style functional designations, based upon Table 7-1, where applicable. This table is to be utilized only when an ISA 5-1 style designation is not appropriate or clear.*
2. *The above list is not exhaustive, and the designer is expected to follow a similar convention to the above when assigning new signal names. Commonly used signal names should be added to the table.*
3. *ISA 5.1 style designations are to utilize capital letters only. Non ISA-5.1 designations are to use a first capital letter, followed by lowercase letters.*
4. *A combination of ISA and non-ISA designations is permissible, provided they are connected via an underscore. For example: HS_Rem represents a hand switch remote position for a non-identified switch on a piece of equipment.*

7.8.2 Discrete Output Signals

Identification of discrete output signals (I/O) will be as follows:

E*	.	Cmd	F	-	S
Controlled Equipment / Instrument Identifier	.	Output Designation	Functional Signal Designation	-	Suffix (Optional)

Where,

- E*** is the *Controlled Equipment / Instrument Identifier*, based upon other parts of this document.
- Cmd** Is the *Output Designation*, utilized to identify all outputs signals.
- F** is the *Functional Signal Designation*, which represents the type of discrete signal. The *Functional Signal Designation* shall be based on Table 7-8.
- S** is the optional *Suffix*, which is a number utilized to differentiate between multiple similar signals.

Examples:

- AHU-M602.CmdRun Motor run output signal for AHU-M602.
- VFD-M602.CmdEnb Enable command to the VFD-M602, which is associated with AHU-M602. The *Controlled Equipment / Instrument Identifier* is deemed to be the VFD, as the enable command is deemed to be specific to the VFD.
- YL-M6011.CmdOn Output signal to turn on pilot light YL-M6011.
- XV-S3810.CmdCls Close signal command to valve XV-S3810.

Table 7-8 : Discrete Output Functional Signal Designations

Signal	Description
.CmdRun	Run Command
.CmdRst	Fault Reset Command
.CmdCls	Close Command
.CmdOpn	Open Command
.CmdEnb	Enable Command

Notes:

- The above list is not exhaustive, and the designer is expected to follow a similar convention to the above when assigning new signal names. Commonly used signal names should be added to the table.
- All discrete outputs are to be prefixed with the Cmd designation.

7.8.3 Analog Signals Generated From Equipment

Identification of analog control system software I/O and signal tags, where the source of the signal is not identified as an instrument, will be as follows:

E*	.	F	_	S
Equipment Identifier	.	Functional Variable		Suffix (Optional)

Where,

- E*** is the *Equipment Identifier*, based upon other parts of this document.
- F** is the *Functional Variable*, which represents the type of analog signal. This field is only required for multivariable transmitters. The *Functional Variable* shall be based on the first column of Table 7-1, with an optional character from the second column. Note that the *Functional Variable* is based upon ISA 5.1.
- S** is the optional *Suffix*, which can be any short designation appropriate to represent the specific signal. Ideally the suffix will be four characters or less. The *Suffix* is separated from the Functional Variable by an underscore.

Note:

1. Do not use this format for analog signals from identified instruments. Refer to Section 7.8.4.

Examples:

UPS-G702.E_Bat	UPS-G702 Battery Voltage Level
UPS-G702.E_In	UPS-G702 Input Voltage Level
UPS-G702.E_Out	UPS-G702 Output Voltage Level
VFD-G101.T	VFD-G101 internal temperature.
CB-M01.RLY.E_An	The voltage signal between phase A and neutral for the protection relay associated with circuit breaker CB-M01.
MS-S501.I_A	The phase A current associated with motor starter MS-S501.

7.8.4 Analog Measured Signals Generated From Instruments

Identification of analog control system software I/O and signal tags, where the source of the signal is an instrument, will be as follows:

I*	.	F	_	S
Instrument Identifier	.	Functional Variable (Optional)	_	Suffix (Optional)

Where,

- I* is the *Instrument Identifier*, based upon other parts of this document.
- F is the *Functional Variable*, which represents the type of analog signal. This field is only required for multivariable transmitters. The *Functional Variable* shall be based on the first column of Table 7-1, with an optional character from the second column. Note that the *Functional Variable* is based upon ISA 5.1.
- S is the optional *Suffix*, which can be any short designation appropriate to represent the specific signal. Ideally the suffix will be four characters or less. The *Suffix* is separated from the *Functional Variable* via an underscore.

Examples:

MT-G6231	Moisture signal of MT-G6231
FT-S5122.P	Pressure signal of differential pressure based flow transmitter FT-S5122.
FT-S5122.F	Flow signal of multivariable transmitter FT-S5122.
FT-S5122.T	Temperature signal of multivariable transmitter FT-S5122.
FV-G6821.Z	Position of damper FV-G6821.
PDT-G4231.P_H	High side pressure of differential pressure transmitter PDT-G4231.
PDT-G4231.P_L	Low side pressure of differential pressure transmitter PDT-G4231.
PDT-G4231.PD	Differential pressure of differential pressure transmitter PDT-G4231.
TT-M613	TT-M613 temperature signal

7.8.5 Analog Output Signals

Identification of analog control system software I/O and signal tags, where the source of the signal is a controller such as a PLC, will be as follows:

E*	.	Cmd	F	-	S
Controlled Equipment / Instrument Identifier	.	Output Designation	Functional Variable	-	Suffix (Optional)

Where,

- E*** is the *Controlled Equipment / Instrument Identifier*, based upon other parts of this document. The *Controlled Equipment / Instrument Identifier* should be the ultimate controlled equipment.
- Cmd** Is the *Output Designation*, utilized to identify all outputs signals.
- F** is the *Functional Variable*, which represents the type of analog signal. The *Functional Variable* shall be based on the first column of Table 7-1, with an optional character from the second column. Note that the *Functional Variable* is based upon ISA 5.1.
- S** is the optional *Suffix*, which can be any short designation appropriate to represent the specific signal. Ideally the suffix will be four characters or less. The *Suffix* is separated from the *Functional Variable* via an underscore.

Examples:

- FV-M215.CmdZ Valve position command signal.
- P-M210.CmdS Pump speed command signal. Note that the pump is the ultimate controlled equipment and not the variable speed drive.
- BLR-B610.CmdT Boiler temperature command signal. This would be appropriate when the boiler has an integral dedicated controller, that is the destination of this signal.
- TC-B610.CmdT Temperature command / setpoint signal to an external temperature controller TC-B610.
- TV-G6822.CmdZ Temperature valve position command signal.

7.8.6 Control System Software Implementation

Where a control system software implementation does not support the use of the “.” character used in the signal identification, it is recommended to replace the period “.” character with an underscore (“_”). For example:

P-G101.FlT would become P-G101_FlT

8 COMMUNICATION EQUIPMENT

8.1 Identifier Format

The identification format for communication equipment is as follows.

FFFF	-	EEEE	-	P	NNN	-	S
Facility Code (Optional)	-	Equipment Functional Designation	-	Process Area	Equipment Number	-	Suffix (Optional)

Where,

- FFFF** is the *Facility Code*, from Appendix A. The *Facility Code* will typically be implied, and would only be fully written where required.
- EEEE** is the *Equipment Functional Designation*, which is comprised of 2 to 4 characters from Section 8.2.
- P** is the *Process Area*, which is based on Section 2.3.
- NNN** is the *Equipment Number*. Select numbers consistent with the ranges in Appendix D.
- S** is the *Suffix*, an optional numeric or letter code to distinguish between multiple pieces of equipment with a common equipment number. Generally, numbers are utilized for equipment in series, and letters for equipment in parallel.

Examples:

- NSW-G901 An Ethernet switch located in the G process area.
- JBN-G110 A networking junction box associated with pump P-G110.
- NJ-G901-1 A networking jack associated with NSW-G901.

8.2 Functional Designations

Table 8-1 : Communication Equipment Functional Designations

Functional Designation	Description	Notes
ANT	Antenna	
CN	Network Cable	
JBN	Junction Box - Network	
MDM	Modem	
NAP	Network Access Point	
NFW	Network Firewall	
NGW	Network Gateway	
NJ	Network Jack	
NJT	Network Jack – Telephone	
NMC	Network Media Converter	
NP	Networking Panel	
NPP	Networking Patch Panel	
NRD	Network Radio	
NRT	Network Router	
NSW	Network Switch, Ethernet	

Notes:

1. *Avoid overlap of Communication Equipment Functional Designations with Electrical, Mechanical, and Automation Functional Designations*

8.3 Network Cables

The identification format for network cables is as follows.

CN	-	P	NNN	-	S
Cable Designation	-	Process Area	Equipment Number of Associated Equipment	-	Suffix (Optional)

Where,

- CN** is the *Cable Designation*, which for network cables is comprised of the letters CN.
- P** is the *Process Area*, which is based on Section 2.3.
- NNN** is the *Equipment Number* of the associated equipment. Where the cable connects two pieces of equipment, identify by the downstream, or serviced piece of equipment.
- S** is the *Suffix* utilized to identify the specific cable associated with the equipment. The Suffix is not required if a single cable is associated with the equipment. Utilize sequential numbers for cables in series, or for different purposes, and letters for cables in parallel. Utilize the letter T to designate tie connections.

Examples:

- CN-G901-1 An uplink network cable for NSW-G901.
- CN-M2531 A network cable that connects level transmitter LT-M2531.
- CN-M801 A network cable that connects PLC-M801 to NSW-M910.

Appendix A Facility Codes

Facility Code	Facility
0001 - 0099	Unused – Future
0100 - 0109	Wastewater Treatment Facilities
0101	North End Water Pollution Control Centre (NEWPCC)
0102	South End Water Pollution Control Centre (SEWPCC)
0103	West End Water Pollution Control Centre (WEWPCC)
0110 - 0399	Collections Facilities – Lift, Flood Pumping, CSO & Diversion Stations
0111	DISCONTINUED – Was Perimeter Road Pumping Station. Utilize WEWPCC Facility Code for the Perimeter Road Pumping Station.
0112	Alexander Diversion Station
0113	Armstrong Diversion Station
0114	Ash Lift and Flood Pumping Stations
0115	Assiniboine Flood Pumping Station
0116	Aubrey Lift and Flood Pumping Stations
0117	Baltimore Lift and Flood Pumping Stations
0118	Bannatyne Flood Pumping Station
0119	Barker Lift Station
0120	Bournais / Mission Gardens Lift Station
0121	Burrows Lift Station
0122	Camiel Lift Station
0123	Chataway Lift and Flood Pumping Station
0124	Clarence Lift Station
0125	Clifton Lift and Flood Pumping Stations
0126	Cloutier Lift Station
0127	Cockburn Lift and Flood Pumping Station
0128	Colony Flood Pumping Station and Diversion Chamber
0129	Spare
0130	Community Lift Station
0131	Conway Lift Station
0132	Cornish - Pumping Station - Flood
0133	Cornish Lift Station
0134	Crane Lift Station
0135	Darcy Lift Station
0136	Despins Lift and Flood Pumping Stations
0137	Dublin Lift Station
0138	Dugald Road Lift Station
0139	Dumoulin Lift and Flood Pumping Stations

	Identification Standard	Revision: 00	Page 96 of 120
		Document Code: 510276-0000-40ER-0002	

Facility Code	Facility
0140	Elmhurst Lift Station
0141	Ferry Road Lift Station
0142	Galt Flood Pumping Station
0143	Grandmont Lift Station
0144	Hart Lift and Flood Pumping Stations
0145	Hawthorne Lift and Flood Pumping Station
0146	Heritage Lift Station
0147	Holland Lift Station
0148	Jefferson Flood Pumping Station (and Diversion Chamber)
0149	Jessie Lift and Flood Pumping Stations
0150	Spare
0151	Kilkenny Lift Station
0152	King Edward Lift Station
0153	Larchdale Lift Station
0154	Laverendrye - Pumping Station - Flood
0155	Linden Lift and Flood Pumping Stations
0156	Louelda Lift Station
0157	Mager Dr. Lift and Flood Pumping Stations
0158	Manitoba Lift Station
0159	Marion Lift and Flood Pumping Stations
0160	Mayfair Lift and Flood Pumping Stations
0161	Metcalfe Flood Pumping Station
0162	Metcalfe Lift Station
0163	Mission Flood Pumping Station
0164	Montcalm Lift Station
0165	Munroe Diversion Chamber
0166	Newton Flood Pumping Station and Diversion Chamber
0167	Notre Dame Lift Station
0168	Oakgrove Lift Station
0169	Olive Lift Station
0170	Pandora Lift Station
0171	Parklane Lift Station
0172	Parkwood Lift Station
0173	Polson Flood Pumping Station and Diversion Chamber
0174	Portsmouth Lift Station
0175	Pulberry Lift Station
0176	Future (Was Ravelston Land Drainage Pumping Station → moved to 0447)
0177	Ridgedale Lift Station

	Identification Standard	Revision: 00	Page 97 of 120
		Document Code: 510276-0000-40ER-0002	

Facility Code	Facility
0178	Riverbend Lift Station
0179	Roland Flood Pumping Station
0180	Ryan Lift Station
0181	Selkirk Flood Pumping Station (and Diversion Chamber)
0182	Somerville Lift Station
0183	<i>Future</i>
0184	St. Charles Lift Station
0185	St. Johns Flood Pumping Station (and Diversion Chamber)
0186	St. Norbert / X-Kaley Flood Pumping Station
0187	St. Norbert Lift Station
0188	Strathmillan Diversion Chamber
0189	Syndicate Lift and Flood Pumping Stations
0190	Thibault Lift Station
0191	Trappiste Lift Station
0192	Tuxedo Lift Station
0193	Tylehurst Lift Station
0194	Westwood Lift Station
0195	Wexford Lift Station
0196	Willow Lift Station
0197	Windsor Park Lift Station
0198	Woodhaven Lift Station
0199	Assiniboine Park Lift Station
0200	Canora Flood Pumping Station
0201	Crescent Drive Lift Station
0202	Ducharme High Level Site
0203	Enfield Crescent Lift Station
0204	Fort Rouge Park Flood Pumping Station
0205	Irving Place Lift Station
0206	Kildare & Floodway Flood Pumping Station
0207	Kildonan Park Lift Station
0208	Perimeter West Lift Station
0209	Rainbow Stage Lift Station
0210	Saskatchewan Lift Station
0211	University of Manitoba Lift Station
0212	University of Winnipeg CSO Storage
0213	Victoria Crescent Lift Station

	Identification Standard	Revision: 00	Page 98 of 120
		Document Code: 510276-0000-40ER-0002	

Facility Code	Facility
0300 – 03xx	Land Drainage – Pumping Sites
0301	Archibald Underpass Station
0302	Bishop Grandin Underpass Station
0304	Keewatin Underpass Station
0305	Kenaston Underpass Station
0306	Kilkenny & Rice (600 LDS) Pumping Station
0308	McPhillips Underpass Station
0309	Metro Route 20 Underpass Station
0310	Metro Route 90 Underpass Station
0311	Osborne Underpass Station
0314	St. James Underpass Station
0316	Turnbull Drive
0400 - 0599	Land Drainage – Storm Retention Basins
0401	1-1 Weston South of Alexander Ave
0412	2-2 St. James, Off Isbister Street north of Hamilton Avenue
0413	2-3 St. James, Southwest of Lumsden Ave and Lake Ridge Rd
0414	2-4 St. James North of South Lake Drive
0415	2-5 Omand's Creek Industrial, North of Whitfield Ave in Omand's Creek Industrial Park
0421	3-1 Maples South-east corner of King Edward St and Selkirk Ave
0422	3-2 Maples North-east corner of King Edward St and Burrows Ave
0423	3-3 Maples North of Burrows Avenue at Benbow Road
0424	3-4 Maples North-east corner of Garton Avenue and Belton Street
0425	3-5 Riverbend North-west of Red River Boulevard and Riverstone Rd
0426	3-6 Maples North of Templeton Avenue and west of McPhillips St
0428	3-8 Maples East of Keewatin St and south of Adsum Dr
0429	3-9 Maples Foxwarren Drive west of Ritchie Street
0430	3-10 Amber Trails West of Amber Trail and Ambergate Dr.
0431	3-11 North Inkster Industrial East of Meridian Dr and Inksbrook Dr
0432	3-12 North Inkster Industrial East of Meridian Dr and north of Commercial Ave
0433	3-13 Amber Trails East of Strasbourg Dr and south of Thorn Dr
0434	3-14 Amber Trails West of Massalia Dr.
0442	4-2 East Kildonan Off Gateway Rd north of Springfield Rd (Bunn's Creek)
0443	4-3 Transcona Cordite Ditch
0444	4-4 Kilcona Park Northeast Park recreation area (Harbourview Complex)
0445	4-5 Transcona North-west corner of Devonshire Dr and Clouston Dr
0446	4-6 Transcona South-east of Devonshire Dr and Kildonan Meadow Dr
0447	4-7 Transcona Deep Pond south-west Ravelston Ave
0448	4-8 Kilcona Park Northeast corner of Lagimodiere Blvd and Springfield

	Identification Standard	Revision: 00	Page 99 of 120
		Document Code: 510276-0000-40ER-0002	

Facility Code	Facility
0449	4-9 Harbourview South South of McMahon Place off McLellan Drive
0450	4-10 East Kildonan North of Ragsdill between East Spring and West Spring
0451	4-11 Eaglemere South of Eaglemere Drive
0452	4-12 East Elmwood North-west of Lagimodiere Blvd and Callsbeck Ave
0454	4-14 Arrowwood South of Headmaster Row and west of Mitchelson Way
0455	4-15 Harbourview South East of Lagimodiere Blvd and north of Concordia Ave
0461	5-1 St Boniface Industrial West of Beghin Ave at Paquin Rd
0462	5-2 St Boniface Industrial East of Paquin Rd
0463	5-3 St Boniface Industrial South of Camiel Sys. St, east of Ray Marius Rd
0464	Waterside Estates West of Plessis south of Dugald
0465	5-5 Southdale North-east corner of Lakewood Blvd and Edgewater Dr
0466	5-6 Southdale West of Beaverhill Blvd and north of Edgewater Dr
0467	5-7 Southdale North-west corner of Lakewood Blvd and Beaverhill Blvd
0468	5-8 Southdale South of Edgewater between Sweetwater and Beaverhill
0469	5-9 Southdale East corner of Shamrock Dr and Newcroft Rd
0470	5-10 Southdale South of Willowlake Cr at Willow Point Rd
0471	5-11 North St Vital North of Bishop Grandin at Kearney St
0472	5-12 North St Vital North of Bishop Grandin at Glen Meadow Street
0473	5-13 North St Vital North of Bishop Grandin at River Rd
0475	5-15 Island Lakes South of Island Shore Blvd
0476	5-16 St Vital South-west of Burland and Healy Cr
0477	5-17 St Vital South-east of Burland and Westbourne Cr
0478	5-18 St Vital East of Dakota St and south of John Forsythe Ave
0479	5-19 Island Lakes South of Island Lakes Drive
0480	5-20 Island Lakes Northwest of Island Lakes Dr of Blvd de la seigneurie
0481	5-21 Southland Park East and North of Royal Mint Dr
0482	5-22 Royalwood South-west corner of Shorehill Drive and Aubin Drive
0483	5-23 South Transcona North-west of St. Boniface Rd and Murdock Rd
0484	5-24 Royalwood Along Westwater Dr
0485	5-25 Royalwood East of Shorehill Dr and Bridgetown Dr
0488	5-28 Sage Creek North of Warde east of Lagimodiere
0489	5-29 Sage Creek West of Des Hivernants Blvd. north of Woodsage Cr.
0490	5-30 Sage Creek North of Tallgrss Cres. east of Des Hivernants Blvd.
0491	5-31 Sage Creek East of hydro ROW , north of Red Lily Rd. South of Blue Sun Dr.
0492	5-32 Sage Creek North of Warde, west of Blue Sun Dr. and east of Red Lily Rd.
0493	5-33 Sage Creek East of Lagimodier Blvd. west of Burning Glass Rd.

	Identification Standard	Revision: 00	Page 100 of 120
		Document Code: 510276-0000-40ER-0002	

Facility Code	Facility
0494	5-34 Sage Creek North of David Friesen Rd.between Des Hivernants Blvd and Burning Glass Rd.
0495	5-35 Sage Creek East of Des Hivernants Blvd and west of Hydro ROW
0496	Sage Creek Lake 9- West of Wild Iris Wk & North of Prarie Smoke Dr.
0497	Sage Creek Lake 10- East of Wild Iris Wk & South of Vireo Ln.
0498	Sage Creek Lake 12-South of Warde Av. & East of Robert Bockstael Dr.
0511	6-1 Assiniboine Forest Assiniboine Forest Grant and Chalfont
0514	6-4 West Fort Garry Business Lot 16 Drain west of Waverley
0515	6-5 Fort Garry Industrial Ditch along Bishop Grandin
0516	6-6 Waverley Heights North of Chancellor between Swan Lake and Lake Grove
0517	6-7 Waverley Heights Along Lake Lindero Rd
0518	6-8 Waverley Heights South of Markham Rd at Forest Lake Dr
0519	6-9 Waverley Heights North of Markham Rd west of Forest Lake Dr
0520	6-10 Fort Richmond North of Dalhousie Dr and east of Pembina Hwy
0521	6-11 Fort Richmond South of Dalhousie Dr and east of Pembina Hwy
0522	6-12 St Norbert North of Grandmont Blvd and west of Nolin Ave
0523	6-13 St Norbert South of Grandmont Blvd and west of Delorme Bay
0524	6-14 West Fort Garry Business East of Kenaston Blvd and south of Scurfield Blvd
0525	6-15 Lindenwoods West of Shorecrest Dr
0526	6-16 Richmond WestPoint West Dr
0527	6-17 Whyte Ridge South-west of Scurfield Blvd and Columbia Dr
0528	6-18 Lindenwoods North of Shoreline Dr and south of Queens Park Cr
0529	6-19 Tuxedo West South of West Taylor Dr and west of Dumbarton Blvd
0530	6-20 Whyte Ridge West of Scurfield Dr and south of Vanderbilt Dr
0531	6-21 St Norbert South of Bellemer Dr (Grandmont Park)
0532	6-22 Lindenwoods North of Wilkes Ave and west of Waverly St
0533	6-23 Tuxedo Industrial West of Kenaston Blvd
0534	6-24 Lindenwoods East of Lindenwoods Drive W
0535	6-25 Linden Ridge East of Dovercourt Drive
0539	6-29 Fairfield Park South of Lee Blvd and west of Raphael St
0542	6-32 Waverley West (South Pointe) WW Lake #1, west of Autumn View and east of Cypress Ridge Rd
0543	6-33 Waverley West (South Pointe) WW Lake #2, west of York Valley & north of Kirkbridge Dr.
0544	6-34 Waverley West (South Pointe) WW Lake #3, south of Kirkbridge Dr and west of Waterstone

	Identification Standard	Revision: 00	Page 101 of 120
		Document Code: 510276-0000-40ER-0002	

Facility Code	Facility
0545	6-35 Waverley West (South Pointe) WW Lake #4, south of Northern Lights Dr & north of Turnstone
0546	6-36 Waverley West (Bridgewater Forerst) WW Lake #1, south of Bridgeland Dr and east of Prominence Pt
0547	6-37 Waverley West (Bridgewater Forerst) WW Lake #2, west of Highland Creek Rd and north of Hunterbrook Rd
0548	6-38 Waverley West (Bridgewater Forerst) WW Lake #3, west of Park Valley Rd and south of North Town Rd
0550	6-40 Waverley West (South Pointe) WW Lake #5, west of Waverly & east of Stan Baile Dr.
0551	Bridewood Estates East of Edward Schreyer opposite Condordia

	Identification Standard	Revision: 00	Page 102 of 120
		Document Code: 510276-0000-40ER-0002	

Facility Code	Facility
0600 - 0799	Water System Facilities
0600	Shoal Lake Intake Facility
0601	Water Treatment Plant
0620	DISCONTINUED (was Deacon Booster Pumping Station, now part of the Water Treatment Plant)
0630	MacLean Water Pumping Station
0640	McPhillips Water Pumping Station, Control Centre, and Collections Building
0650	Hurst Water Pumping Station
0660	Taché Booster Pumping Station
0701	General Shoal Lake Aqueduct & GWWD
0702	St. Boniface Shops
0703	M17.05 Boathouse
0704	M22.53 RTU
0705	M29.76 RTU
0706	M34.40 RTU
0707	Ross (Yard and Backbone Repeater)
0708	M39.39 Boathouse
0709	M42.05 Boathouse
0710	M56.71 RTU
0711	Hadashville (Yard and Backbone Repeater)
0712	M64.08 Boathouse
0713	M69.51 RTU
0714	M73.63 Boathouse
0715	M77.63 Boathouse
0716	East Braintree
0717	M82.06 Boathouse
0718	M82.44 Backbone Repeater
0719	M83.02 Boathouse
0720	M88.64 RTU
0721	M93.69 RTU
0722	M96.69 Boathouse
0751	Branch 1 Aqueduct
0752	Branch 2 Aqueduct

	Identification Standard	Revision: 00	Page 103 of 120
		Document Code: 510276-0000-40ER-0002	

Facility Code	Facility
0801	Standpipe Water Service – 1539 Waverly Street
0802	Standpipe Water Service – Portage Avenue at Perimeter Highway (McCarthy St. and Oxbow Bend Rd.)
0812	Pressure Monitoring Location – Gateway Rd and Springfield Rd
0814	Pressure Monitoring Location – Inkster Blvd and Brookside Blvd
0816	Pressure Monitoring Location – John Black Ave and Main St
0818	Pressure Monitoring Location – Lagimodiere Blvd at Offtake to Smuggler’s Cove
0820	Pressure Monitoring Location – Paddington Rd and Charing Cross Cres
0822	Pressure Monitoring Location – Pembina Hwy and Chancellor Matheson Rd
0824	Pressure Monitoring Location – Plessis Rd and Devonshire Dr
0826	Pressure Monitoring Location – Redonda St and Kildare Ave
0828	Pressure Monitoring Location – Redonda St and Kildare Ave
0830	Pressure Monitoring Location – Rue Des Trappistes and Villeneuve Blvd
0832	Pressure Monitoring Location – Sargent Ave and St. James St
0900 - 0999	Unused - Future

Appendix B Facility Process Area Codes

Process Area Codes – Shoal Lake Intake Facility

Process Area	Description
A	General or process area is not applicable
C	Chlorine Area
D	Dechlorination Building
E	Engine Shed
H	Electrical Shed
G	Gatehouse
P	Pumphouse (including Electrical & Control Room)
R	Residences
S	Staff Houses

Process Area Codes – Shoal Lake Aqueduct

Process Area	Description
A	Aqueduct and Related Small Facilities including Boathouses and RTU Sites
R	GWWD Railway

Process Area Codes – Water Treatment Plant

Process Area	Description
A	Administration
B	Main Treatment Plant Building
C	Chemical Feed Systems (Polymer, SBS, Hydrogen Peroxide)
D	Deacon Booster Pumping Station (includes Ultraviolet Light Disinfection)
E	Electrical Substation
F	Filtration
G	Standby Power Generation
H	Plant Utilities
I	Inlet Works and Raw Water Pumping
J	Hypochlorite Generation and Feed Building
K	Enclosed Bridge
L	Dewatering Cells (Freeze Thaw Pond) / Forcemain
M	General Plant Services / Miscellaneous (incl. Fire Pump Room and Electrical Room)
N	Aqueduct Bridges
O	Ozone
P	Flocculation and DAF
R	Residuals Handling
S	Bulk Chemical Storage and Feed Building
T	Treatment Water Storage (Clearwell)
U	<i>Future</i>
V	Civil Maintenance and Aqueduct Storage Building
W	<i>Future</i>
X	Pilot Plant
Y	Yard Piping and Valve Chamber
Z	Deacon Chemical Feed Building

Note: The current application of process areas does not meet the intent of this standard, in that it is not based upon a physical location. For example, the H process area is for all plant utilities across the entire building.

Process Area Codes – Regional Water Pumping Stations

Process Area	Description
A	General or process area is not applicable
B	Collections Building (McPhillips only)
C	Chlorine Building / Area
M	Main Pumping Station Building
R	Reservoir
S	Control Centre Building (McPhillips Only)
Y	Yard Piping and Valve Chambers

Process Area Codes – Wastewater Collections

Process Area	Description
A	General or process area is not applicable
F	Flood Pumping Stations
L	Wastewater Lift Stations
S	Sewer

Process Area Codes – Land Drainage

Process Area	Description
A	General or process area is not applicable
B	Storm Retention Basin (SRB)
L	Pumping Station
U	Underpass Pumping Station
W	Deep Well Pump

Process Area Codes – NEWPCC

Process Area	Description
A	General or process area is not applicable
B	Boilers
C	Centrate Treatment
D	Digesters
F	Phosphorous Removal Facility
G	Pre-Aeration and Grit Removal
H	<i>HOLD – Potentially reserve for Headworks process area. Decision to be made under the sewage treatment upgrade program.</i>
M	Main Building
P	Primary Clarifiers
R	Oxygen Reactors
S	Secondary Clarifiers
U	UV Disinfection Facility
W	Sludge Dewatering
X	Leachate Receiving Facility
Y	Hauled Wastewater Receiving Facility

Process Area Codes – SEWPCC

Process Area	Description
A	General or process area is not applicable
B	Service Building, Boilers, Chemical Storage Building
G	Pump & Screen Building, Grit Building, Standby Generator Building
H	<i>HOLD – Potentially reserve for Headworks process area. Decision to be made under the sewage treatment upgrade program.</i>
M	Administration Building and Septage Facility
P	Primary Clarifiers
R	Oxygen Reactors
S	Secondary Clarifiers
U	UV Disinfection Facility (See Note 1)
Y	<i>HOLD – Possible use for Yard. Decision to be made under the sewage treatment upgrade program.</i>
Z	UV Disinfection Facility (Historical, See Note 1)

Notes:

1. *Most of the existing equipment within the SEWPCC UV Disinfection facility is identified with the Z process area. It is desired that all new work and modifications in this facility utilize the U process letter.*

Process Area Codes – WEWPCC

Process Area	Description
A	General or process area is not applicable
F	Primary Sludge Fermenters
H	Headworks
L	General and Site Works
M	Perimeter Road Pumping Station
P	Primary Clarifiers
S	Secondary Clarifiers and BioReactors
T	DAF (Dissolved Air Flotation) Thickeners
U	Utility Building HOLD – Possible re-allocation for future UV Disinfection
V	HOLD – Possible re-allocation as the Utility Building. (See Note 1)
Y	<i>HOLD – Possible use for Yard. Decision to be made under the sewage treatment upgrade program.</i>

Notes:

1. *Some equipment in the WEWPCC Utility Building has already been re-identified as V.*

Process Area Codes – Solid Waste

Process Area	Description
A	General or process area is not applicable
B	Biosolids and LYW Composting

Appendix C Master Equipment Functional Designations

Functional Designation	Description	Type	Notes
AD	Air Dryer	Mechanical	
ACP	Access Control Panel	Security	
ADP	Automation Device Panel	Automation	
AF	Aeration Fan	Mechanical	
AG	Agitator	Mechanical	
AHU	Air Handling Unit	Mechanical	Includes Make-Up Air Units
ANT	Antenna	Communication	
ATS	Automatic Transfer Switch	Electrical	
B	Blower	Mechanical	
BAT	Battery	Electrical	
BC	Battery Charger	Electrical	
BD	Balance Damper	Mechanical	See Section 4.3.
BFP	Back Flow Preventer	Mechanical	
BLR	Boiler	Mechanical	
BS	Bar Screen	Mechanical	
BUS	Busway	Electrical	
C	Cable (Power)	Electrical	
CA	Cable (Automation)	Automation	
CAL	Calibration Column	Mechanical	
CAP	Capacitor	Electrical	Typically individual unit. See PFC.
CB	Circuit Breaker	Electrical	Includes air, vacuum, SF6, and moulded case circuit breakers
CBUS	Cable Bus	Electrical	
CC	Cooling Coil	Mechanical	
CDR	Condensor	Mechanical	
CE	Centrifuge	Mechanical	
CHLR	Chiller	Mechanical	
CM	Clarifier Mechanism	Mechanical	
CMP	Compressor	Mechanical	
CN	Network Cable	Communication	
CNV	Conveyor	Mechanical	Includes skimmers
CON	Contactora	Electrical	
CP	Control Panel	Electrical	
CP	Control Panel	Automation	

Functional Designation	Description	Type	Notes
CPR	Cathodic Protection Rectifier	Electrical	
CRN	Crane	Mechanical	
CS	Computer Server	Automation	
CSTE	Customer Service Termination Equipment	Electrical	
CT	Cooling Tower	Mechanical	
CU	Condensing Unit	Mechanical	
CV	Check Valve	Mechanical	
CW	Computer Workstation - General	Automation	
CWD	Computer Workstation - Development	Automation	
CWO	Computer Workstation - Operator	Automation	
DCS	Distributed Control System	Automation	
DP	Distribution Panel	Electrical	
DS	Disconnect Switch (non-fusible)	Electrical	
EF	Exhaust Fan	Mechanical	
ELB	Emergency Lighting Battery Pack	Electrical	May have integrated lights.
F	Fan - General	Mechanical	
FA	Flame Arrestor	Mechanical	
FAAP	Fire Alarm Annunciator Panel	Electrical	
FACP	Fire Alarm Control Panel	Electrical	
FAS	Fire Alarm System	Electrical	
FC	Fan Coil	Mechanical	
FD	Fire Damper	Mechanical	Utilize same equipment number as air handler.
FDP	Field Device Panel	Automation	
FDR	Feeder	Mechanical	Examples: screw feeder, chlorinator, glycol make-up unit
FDS	Fusible Disconnect Switch	Electrical	
FEX	Fire Extinguisher	Mechanical	
FG	Flap Gate	Mechanical	
FIL	Filter	Mechanical	
FU	Fuse	Electrical	
GDC	Gas Detection Controller	Automation	
GEN	Generator	Electrical	

	Identification Standard	Revision: 00	Page 112 of 120
		Document Code: 510276-0000-40ER-0002	

Functional Designation	Description	Type	Notes
GR	Grille – General	Mechanical	See Section 4.3.
GRD	Grille – Diffuser	Mechanical	See Section 4.3.
HC	Heating Coil	Mechanical	
HCC	Heater Coil Controller	Electrical	Includes SCR and contactor based controllers.
HCE	Heating Coil, Electric	Mechanical	Duct based
HE	Heat Exchanger	Mechanical	
HF	Harmonic Filter	Electrical	
HMI	Standalone Human Machine Interface (HMI) Terminal	Automation	
HO	Hoist	Mechanical	
HOP	Hopper	Mechanical	
HP	Heat Pump	Mechanical	
HRC	Heat Recovery Coil	Mechanical	
HTR	Heater	Mechanical	General heaters, radiant, convectors, etc.
HUM	Humidifier	Mechanical	
HV	Hand/Manual Valve	Mechanical	See Section 5.2
INJ	Injector	Mechanical	
JB	Junction Box	Electrical	
JBA	Junction Box (Automation)	Automation	
JBN	Junction Box - Network	Communication	
K	Interlocking Key (Kirk Key)	Electrical	
LC	Lighting Contactor	Electrical	
LCP	Local Control Panel	Automation	
LDB	Load Bank	Electrical	
MCC	Motor Control Centre	Electrical	
MCP	Motor Circuit Protector	Electrical	
MCS	Moulded Case Switch	Electrical	
MDM	Modem	Communication	
MMS	Manual Motor Starter	Electrical	
MS	Motor Starter	Electrical	
MSP	Motor Starter Panel	Electrical	
MTR	Motor	Electrical	
MTS	Manual Transfer Switch	Electrical	
MXR	Mixer	Mechanical	
NAP	Network Access Point (Wireless)	Communication	
NFW	Network Firewall	Communication	

	Identification Standard	Revision: 00	Page 113 of 120
		Document Code: 510276-0000-40ER-0002	

Functional Designation	Description	Type	Notes
NGR	Neutral Grounding Resistor	Electrical	
NGW	Network Gateway	Communication	
NJ	Network Jack	Communication	
NJT	Network Jack - Telephone	Communication	
NMC	Network Media Converter	Communication	
NP	Networking Panel	Communication	
NRA	Network Radio	Communication	
NRT	Network Router	Communication	
NSW	Network Switch, Ethernet	Communication	
OD	Overhead Door	Mechanical	
P	Pump	Mechanical	
PB	Pull Box	Electrical	
PFC	Power Factor Correction Unit	Electrical	Bank of capacitors. May contain reactors.
PLC	Programmable Logic Controller	Automation	
PM	Power Meter	Electrical	
PNL	Panelboard	Electrical	
PRN	Printer	Automation	
PS	Power Supply	Electrical	24VDC power supply
PSP	Power Supply Panel	Electrical	Panel containing 24VDC power supplies, fire alarm booster power supply
R	Reactor (various processes)	Mechanical	
RCPT	Receptacle	Electrical	
RCTR	Reactor	Electrical	
RES	Reservoir	Mechanical	Large water containment structure.
RIO	Remote I/O	Automation	
RTU	Remote Terminal Unit	Automation	
S	Skid Package	Mechanical	
SA	Sampler	Mechanical	
SCBR	Scrubber	Mechanical	
SCP	Security Control Panel	Security	
SCR	Silicon Controlled Rectifier	Electrical	
SF	Supply Fan	Mechanical	
SGR	Switchgear	Electrical	
SL	Stop Logs	Mechanical	
SLG	Sluice Gate	Mechanical	

	Identification Standard	Revision: 00	Page 114 of 120
		Document Code: 510276-0000-40ER-0002	

Functional Designation	Description	Type	Notes
SPL	Splitter	Electrical	
SS	Soft Starter	Electrical	
STR	Strainer	Mechanical	See Section 5.2
SVM	Security Video Monitor	Security	
SVR	Security Video Recorder	Security	
SW	Switch	Electrical	
TBC	Travelling Bridge Collector	Mechanical	
TK	Tank	Mechanical	
TU	Terminal Unit	Mechanical	Includes CAV/VAV/Dual Duct boxes. Dampers to be identified as per Section 7.1 – Instrumentation.
TVSS	Transient Voltage Surge Suppressor	Electrical	
U	Miscellaneous Equipment Not In List	Mechanical	Example: Water Softener
UH	Unit Heater	Mechanical	
UPS	Uninterruptible Power Supply	Electrical	
UVR	Ultra-Violet (UV) Reactor	Mechanical	
V	Vessel, Pressure Vessel	Mechanical	e.g. air receiver, glycol expansion tank
VFD	Variable Frequency Drive	Electrical	
W	Weir	Mechanical	
WGB	Waste Gas Burner	Mechanical	
XFMR	Transformer	Electrical	

Appendix D Equipment Number Ranges

Equipment Number Ranges – Shoal Lake Intake Facility

Process Area	Range	Description
All Process Areas	001 - 049	Major Pumping
	050 - 099	Future
	100 – 499	Process Equipment
	500 – 599	Misc Building Equipment – Air Compressors, Sump Pumps, etc.
	600 - 699	HVAC Equipment
	700 - 799	Electrical Equipment
	800 – 899	Automation Equipment
	900 – 999	Misc, including communication and security

Equipment Number Ranges – Shoal Lake Aqueduct

Process Area	Range	Description
All Process Areas	TBD	Needs to be developed.

	Identification Standard	Revision: 00	Page 116 of 120
		Document Code: 510276-0000-40ER-0002	

Equipment Number Ranges – Water Treatment Plant

Process Area	Range	Description
C – Chemical Feed	001 - 099	Process – Polymer
	100 – 899	Process – Future
	700-799	Electrical Equipment
	800 – 999	Chemical Systems
	900 – 949	Chemical Systems – Hydrogen Peroxide
	950 – 979	Chemical Systems – Sodium Bisulphite
D - Deacon Booster Pumping Station	001 - 049	Major Pumping
	050 - 099	Future
	100 - 499	Process Equipment
	500 – 599	Misc Building Equipment – Air Compressors, Sump Pumps, etc.
	600 – 699	HVAC
	700-799	Electrical Equipment
	800-899	Automation Equipment
	900 – 999	Misc, including communication and security
F - Filtration	001 – 999	Process
H – Plant Utilities	001 - 099	HVAC
	100 - 199	Fire Pumps
	200 - 299	Auxiliary Building HVAC
	300 - 399	Building Safety and Security
	400 - 499	Process Pumps
	500 - 599	Sanitary Sumps
	600 - 699	Electrical Distribution
	700 - 799	Potable Water
	800 - 899	Unallocated
	900 - 950	Emergency Generator
	951 - 999	Electrical Substation
I – Inlet and Raw Water	001 - 999	Process
J – On-Site Hypochlorite Generation	001 - 999	Process
L – Freeze Thaw Pond	001 - 999	Process
O - Ozone	001 - 999	Process
P – Flocculation and DAF	001 - 999	Process
R – Residuals Handling	001 - 999	Process
S – Bulk Chemical Storage	001 - 999	Process
T – Treated Water Storage and Handling (Clearwell)	001 - 999	Process
U – Ultraviolet Light Disinfection	001 - 999	Process

Process Area	Range	Description
Y – Yard Piping and Valve Chambers	001 - 099	Surge Towers
	100 - 199	Yard Piping
	200 - 299	Yard Lighting
Z – Deacon Chemical Feed Building	001 – 099	Process Equipment
	100 - 199	Chemical Systems – Hydrofluosilicic Acid
	200 - 299	Chemical Systems – Phosphoric Acid
	300 - 499	Process Equipment
	500 - 599	Misc Building Equipment – Air Compressors, Sump Pumps, etc.
	600 - 699	HVAC
	700 - 799	Electrical Equipment
	800 - 899	Automation Equipment
	900 - 999	Misc, including communication and security

Note: The above WTP process ranges are largely based upon existing designations. In the event of future significant upgrades, some realignment may be required to fully align with this standard.

Equipment Number Ranges – Regional Water Pumping Stations

Process Area	Range	Description
All Process Areas	001 - 049	Major Pumping
	050 - 099	Future
	100 – 499	Process Equipment
	500 – 599	Misc Building Equipment – Air Compressors, Sump Pumps, etc.
	600 - 699	HVAC Equipment
	700 - 799	Electrical Equipment
	800 – 899	Automation Equipment
	900 – 999	Misc, including communication and security

Equipment Number Ranges – Collections Facilities

Process Area	Range	Description
L – Wastewater Lift Stations or F – Flood Pumping Station or U – Underpass Pumping Station	01 – 49	Reserved for Process Equipment
	01 - 09	Pumps
	10 – 19	Wet Well / Intake Equipment
	20 - 39	Misc Process
	40 - 49	Discharge / Forcemain
	50 - 59	Misc Building Equipment – Air Compressors, Backflow Preventer, etc.
	60 - 69	HVAC Equipment
	70 - 79	Electrical Equipment
	80 – 89	Automation Equipment
	90 - 99	Misc, including communication and security
S – Sewer	01 – 79	Sewer – Misc.
	80 - 89	Sewer – Before Outfall
	90 - 99	Sewer - Outfall

Note: The Collections facilities utilize two digit equipment numbers due to the limited amount of equipment located within each facility. Instrumentation loop numbers within Collections facilities have three digits.

Equipment Number Ranges – Wastewater Treatment Facilities

Process Area	Range	Description
All Process Areas	001 - 099	Major Process Equipment
	100 – 499	Process Equipment
	500 – 599	Misc Building Equipment – Air Compressors, Backflow Preventer, etc.
	600 - 699	HVAC Equipment
	700 - 799	Electrical Equipment
	800 – 899	Automation Equipment
	900 – 999	Misc, including communication and security

Appendix E Sample Drawings

The following process and instrumentation diagram drawings were created as sample drawings.

South End Water Pollution Control Centre

City Drawing Number	Sheet	Rev	Project / Area	TITLE
1-0102A-SK01	001	00		PROCESS & INSTRUMENTATION DIAGRAM, LEGEND AND DETAILS
1-0102A-SK01	002	00		PROCESS & INSTRUMENTATION DIAGRAM, LEGEND AND DETAILS
1-0102A-SK01	003	00		PROCESS & INSTRUMENTATION DIAGRAM, LEGEND AND DETAILS
1-0102S-SK02	001	00	SECONDARY CLARIFIERS	PROCESS & INSTRUMENTATION DIAGRAM, CLARIFIER 1, PROPOSED IDENTIFICATION
1-0102S-SK03	001	00	SECONDARY CLARIFIERS	PROCESS & INSTRUMENTATION DIAGRAM, CLARIFIER 2, PROPOSED IDENTIFICATION
1-0102S-SK04	001	00	SECONDARY CLARIFIERS	PROCESS & INSTRUMENTATION DIAGRAM, CLARIFIER 3, PROPOSED IDENTIFICATION
1-0102S-SK05	001	00	SECONDARY CLARIFIERS	PROCESS & INSTRUMENTATION DIAGRAM, SECONDARY CLARIFIER EFFLUENT & SAMPLE SYSTEM, PROPOSED IDENTIFICATION
1-0102S-SK06	001	00	SECONDARY CLARIFIERS	PROCESS & INSTRUMENTATION DIAGRAM, RETRUN ACTIVATED SLUDGE PUMP P-S101, PROPOSED IDENTIFICATION
1-0102S-SK07	001	00	SECONDARY CLARIFIERS	PROCESS & INSTRUMENTATION DIAGRAM, REPURN ACTIVATED SLUDGE PUMPS P-S102 & P-S103, PROPOSED IDENTIFICATION
1-0102S-SK08	001	00	SECONDARY CLARIFIERS	PROCESS & INSTRUMENTATION DIAGRAM, REPURN ACTIVATED SLUDGE PUMPS P-S108 & P-S109, PROPOSED IDENTIFICATION
1-0102S-SK09	001	00	SECONDARY CLARIFIERS	PROCESS & INSTRUMENTATION DIAGRAM, RAS HEADER, PROPOSED IDENTIFICATION
1-0102S-SK10	001	00	SECONDARY CLARIFIERS	PROCESS & INSTRUMENTATION DIAGRAM, WASTE ACTIVATED SLUDGE PUMPS P-S202 & P-S203, PROPOSED IDENTIFICATION

Marion Wastewater Pumping Station

City Drawing Number	Sheet	Rev	Project / Area	TITLE
1-0159L-SK01	001	00		PROCESS & INSTRUMENTATION DIAGRAM, WASTEWATER PUMPING
1-0159L-SK02	001	00		PROCESS & INSTRUMENTATION DIAGRAM, VENTILATION

MacLean Water Pumping Station

City Drawing Number	Sheet	Rev	Project / Area	TITLE
1-0630A-SK01	001	00		PROCESS & INSTRUMENTATION DIAGRAM, LEGEND & DETAILS
1-0630A-SK01	002	00		PROCESS & INSTRUMENTATION DIAGRAM, LEGEND & DETAILS
1-0630A-SK01	003	00		PROCESS & INSTRUMENTATION DIAGRAM, LEGEND & DETAILS
1-0630C-SK01	001	00		PROCESS & INSTRUMENTATION DIAGRAM, CHLORINE CYLINDER SHUTOFF VALVES
1-0630C-SK02	001	00		PROCESS & INSTRUMENTATION DIAGRAM, CHLORINATION

	Identification Standard	Revision: 00	Page 120 of 120
		Document Code: 510276-0000-40ER-0002	

City Drawing Number	Sheet	Rev	Project / Area	TITLE
				SYSTEM
1-0630M-SK02	001	00		PROCESS & INSTRUMENTATION DIAGRAM, SUCTION HEADER
1-0630M-SK03	001	00		PROCESS & INSTRUMENTATION DIAGRAM, PUMP P-M021
1-0630M-SK04	001	00		PROCESS & INSTRUMENTATION DIAGRAM, PUMP P-M022
1-0630M-SK05	001	00		PROCESS & INSTRUMENTATION DIAGRAM, PUMP P-M023
1-0630M-SK07	001	00		PROCESS & INSTRUMENTATION DIAGRAM, PUMP P-M025
1-0630M-SK08	001	00		PROCESS & INSTRUMENTATION DIAGRAM, PUMP P-M026
1-0630M-SK09	001	00		PROCESS & INSTRUMENTATION DIAGRAM, DISCHARGE HEADER
1-0630M-SK10	001	00		PROCESS & INSTRUMENTATION DIAGRAM, COMPRESSED AIR SYSTEM
1-0630M-SK11	001	00		PROCESS & INSTRUMENTATION DIAGRAM, GEN-M751 & GEN-M752
1-0630M-SK12	001	00		PROCESS & INSTRUMENTATION DIAGRAM, MISCELLANEOUS
1-0630R-SK01	001	00		PROCESS & INSTRUMENTATION DIAGRAM, RESERVOIR FILL VALVES
1-0630R-SK02	001	00		PROCESS & INSTRUMENTATION DIAGRAM, RESERVOIR CELLS
1-0630Y-SK01	001	00		PROCESS & INSTRUMENTATION DIAGRAM, DISCHARGE TO FEEDERMANS