

NOTE: CHAINAGES SHOWN ARE ALONG S. R. OF ASHBURY BAY (SLEG)

ASHBURY BAY (S-LEG)

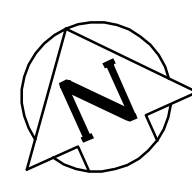

FOR CONTINUATION SEE DWG D-13913

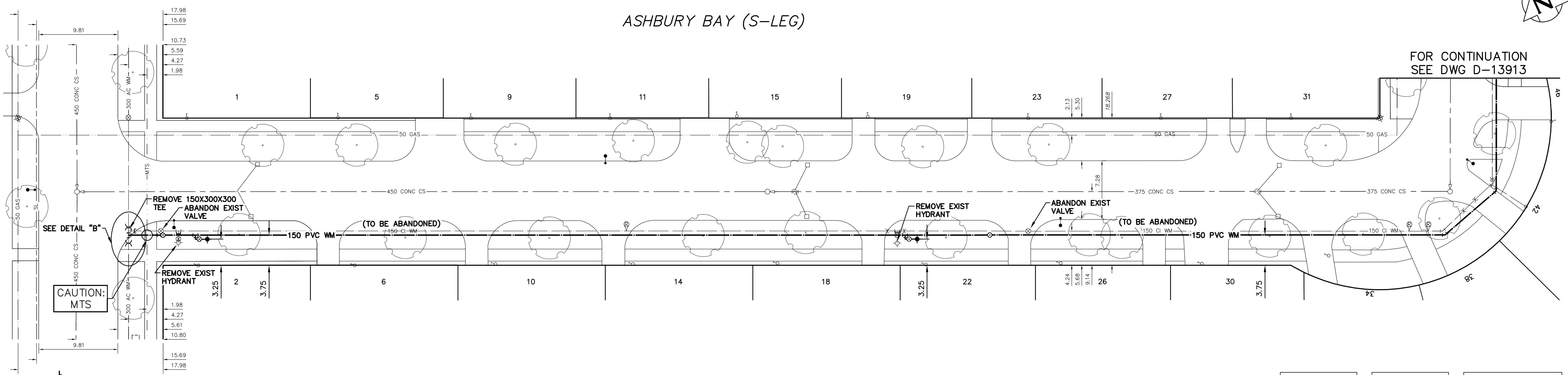

FOR INDEX SEE D-13913      FOR WATER SERVICE TABLE SEE DWG D-13910      VALVES COUNTER-CLOCKWISE TO CLOSE (RED OPERATING NUT)

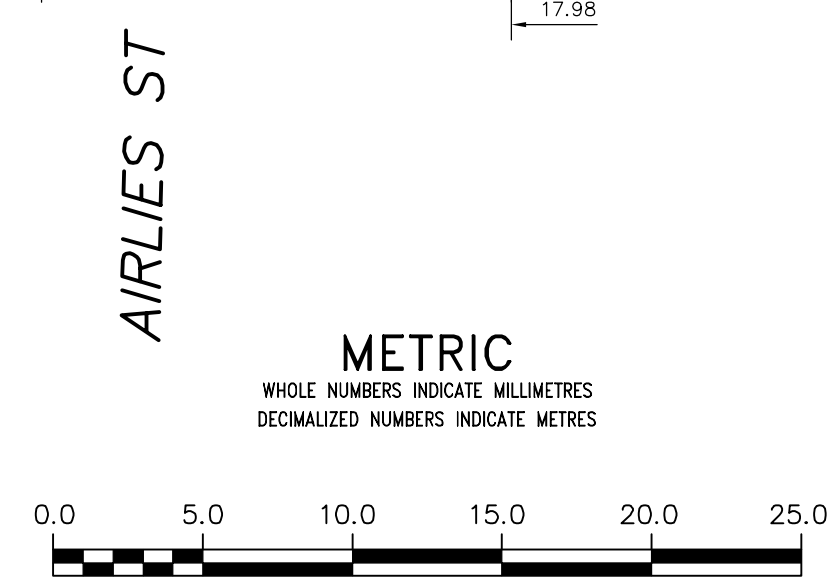

<p><b>WARNING</b></p> <p>IF POWER EQUIPMENT OR EXPLOSIVES ARE TO BE USED FOR EXCAVATION ON THIS PROJECT THE CONTRACTOR MUST:</p> <ol style="list-style-type: none"> <li>1) NOTIFY THE GAS COMPANY OF THE PROPOSED LOCATION OF EXCAVATION.</li> <li>2) TAKE PRECAUTION TO AVOID DAMAGE TO GAS COMPANY INSTALLATIONS.</li> </ol> <p>SEE PROVINCIAL REGULATION 21072 FOR DETAILS</p>	<p>LOCATION APPROVED UNDERGROUND STRUCTURES</p> <p>SUPV. U/G STRUCTURES COMMITTEE      DATE</p> <p>NOTE:</p> <p>LOCATION OF UNDERGROUND STRUCTURES AS SHOWN ARE BASED ON THE BEST INFORMATION AVAILABLE BUT NO GUARANTEE IS GIVEN THAT ALL EXISTING UTILITIES ARE SHOWN OR THAT THE GIVEN LOCATIONS ARE EXACT. CONFIRMATION OF EXISTENCE AND EXACT LOCATION OF ALL SERVICES MUST BE OBTAINED FROM THE INDIVIDUAL UTILITIES BEFORE PROCEEDING WITH CONSTRUCTION.</p>	<p>B.M. ELEV.</p> <p>CONSTRUCTION COMPLETION DATE: YYYY MM DD</p> <table border="1"> <tr><td>NO.</td><td>REVISIONS</td><td>DATE</td><td>BY</td></tr> <tr><td> </td><td> </td><td> </td><td> </td></tr> <tr><td> </td><td> </td><td> </td><td> </td></tr> <tr><td> </td><td> </td><td> </td><td> </td></tr> </table>	NO.	REVISIONS	DATE	BY													<p>DESIGNED BY: JF</p> <p>DRAWN BY: RS/CN</p> <p>SCALE: HORIZONTAL 1:250, VERTICAL 1:50</p> <p>DATE: 2015 05 22</p> <p>PLOT DATE: 2015 05 22</p>	<p>CHECKED BY: SC</p> <p>APPROVED BY: KZ</p> <p>RELEASED FOR CONSTRUCTION</p> <p>DATE:      DATE</p>	<p>ENGINEER'S SEAL</p> <p>ORIGINAL SIGNED BY S.R.J COURNOYER 15/05/21</p> <p>CONSULTANT DRAWING NUMBER: -</p>	<p><b>THE CITY OF WINNIPEG</b></p> <p>WATER AND WASTE DEPARTMENT</p> <p>ENGINEERING DIVISION</p> <p>2015 WATERMAIN RENEWALS</p> <p>ASHBURY BAY (S-LEG)</p> <p>AIRLIES STREET (E R) TO ASHBURY BAY (E-LEG) (W R)</p>	<p>SHEET 4 OF 9</p> <p>CITY DRAWING NUMBER</p> <p>D-13913</p>
			NO.	REVISIONS	DATE	BY																	
<p>BID OPPORTUNITY: XXX-2015</p> <p>CONTRACT NUMBER: 4</p>		<p>FILE PATH: R:\DRAWINGS\WATER\RENEWAL\2015 RENEWAL\CONTRACT 4\ASHBURY.dwg</p>																					