

**FORM A: BID**  
(See B8)

1. Contract Title SUPPLY AND DELIVERY OF SPECIALIZED UTILITY VEHICLES

2. Bidder

\_\_\_\_\_  
Name of Bidder

\_\_\_\_\_  
Usual Business Name of Bidder as it appears on Invoice (if different from above)

\_\_\_\_\_  
Street

\_\_\_\_\_  
City

\_\_\_\_\_  
Province

\_\_\_\_\_  
Postal Code

(Mailing address if different)

\_\_\_\_\_  
Email Address of Bidder

\_\_\_\_\_  
Facsimile Number

\_\_\_\_\_  
Street or P.O. Box

\_\_\_\_\_  
City

\_\_\_\_\_  
Province

\_\_\_\_\_  
Postal Code

(Choose one)

\_\_\_\_\_  
GST Registration Number (if applicable)

The Bidder is:

a sole proprietor

a partnership

a corporation

carrying on business under the above name.

3. Contact Person

The Bidder hereby authorizes the following contact person to represent the Bidder for purposes of the Bid.

\_\_\_\_\_  
Contact Person

\_\_\_\_\_  
Title

\_\_\_\_\_  
Telephone Number

\_\_\_\_\_  
Facsimile Number

\_\_\_\_\_  
Email Address

4. Definitions

All capitalized terms used in the Contract shall have the meanings ascribed to them in the General Conditions and D3.

5. Offer The Bidder hereby offers to perform the Work in accordance with the Contract for the price(s), in Canadian funds, set out on Form B: Prices, appended hereto.

6. Commencement of the Work The Bidder agrees that no Work shall commence until he/she is in receipt of a notice of award from the Award Authority authorizing the commencement of the Work.

7. Contract The Bidder agrees that the Bid Opportunity in its entirety shall be deemed to be incorporated in and to form a part of this offer notwithstanding that not all parts thereof are necessarily attached to or accompany this Bid.

8. Addenda The Bidder certifies that the following addenda have been received and agrees that they shall be deemed to form a part of the Contract:

No.	Dated
_____	_____
_____	_____
_____	_____

9. Time This offer shall be open for acceptance, binding and irrevocable for a period of sixty (60) Calendar Days following the Submission Deadline.

10. Signatures The Bidder or the Bidder's authorized official or officials have signed this \_\_\_\_\_ day of \_\_\_\_\_, 20\_\_\_\_.

Signature of Bidder or  
Bidder's Authorized Official or Officials

\_\_\_\_\_  
\_\_\_\_\_  
(Print here name and official capacity of individual whose signature appears above)

\_\_\_\_\_  
\_\_\_\_\_  
(Print here name and official capacity of individual whose signature appears above)

**FORM B: PRICES**  
 (See B9)

**SUPPLY AND DELIVERY OF SPECIALIZED UTILITY VEHICLES**

**UNIT PRICES**

ITEM NO.	DESCRIPTION	SPEC. REF.	UNIT	QUANTITY	UNIT PRICE
1.	Utility Vehicle Diesel with Cab	15043	Each	2	
1a.	Option 1: Attachments	15043	Each		
	60" Angle Broom,			1	_____
	60" Snow Blower,			1	_____
	62" Low Profile Bucket,			1	_____
	90" Mower Deck			1	_____
1b.	Option 2: Attachments	15043	Each		
	68" Angle Broom,			1	_____
	60" Snow Blower,			1	_____
	68" Combination Bucket,			1	_____
	90" Mower Deck			1	_____

\_\_\_\_\_  
 Name of Bidder

## FORM N: DETAILED SPECIFICATIONS 15043

### SPECIALIZED UTILITY VEHICLE

#### **1.0 DESCRIPTION OF EQUIPMENT**

- 1.1 These specifications describe a **Specialized Utility Vehicle** and other equipment and features as specified herein.
- 1.2 The **Specialized Utility Vehicle** shall be a new 2015 model year or newer.
- 1.3 The **Specialized Utility Vehicle** and all other items/components shall be the manufacturer's latest model. The equipment shall be furnished complete and ready for operation. Any parts or accessories not specifically mentioned, but which are required to complete and place the equipment and associated attachments in successful operation shall be furnished as though specifically mentioned in these specifications. The equipment and associated attachments, and all parts thereof, shall conform in strength and quality of material and workmanship, to the best standards and engineering practice of the industry.
- 1.4 It will be the responsibility of the Bidder to inform the City of any errors or omissions in these specifications, for under this Contract the Contractor shall be held responsible for the satisfactory operational function of the equipment.

#### **2.0 OTHER SPECIFICATIONS AND STANDARDS**

- 2.1 All applicable SAE standards form an integral part of these specifications and shall have precedence in any conflict concerning minimum acceptable standards.
- 2.2 The **Specialized Utility Vehicle** shall comply with the applicable regulations:

National Safety Mark, NSM = <http://www.tc.gc.ca/eng/acts-regulations/acts-road.htm>

Manitoba Safety and Health Act, Parts 12, 22 =  
<http://web2.gov.mb.ca/laws/statutes/ccsm/w210e.php> and <http://www.gov.mb.ca/labour/safety/>

Canadian Standards Association, CSA = <http://www.csa.ca/about/Default.asp?language=english>

Under Writers of Canada, U/L = <http://www.ulc.ca/>

Society of Automotive Engineers, SAE = <http://www.sae.org/>

City of Winnipeg Lighting Visibility  
Standard=<http://winnipeg.ca/matmgt/pdfs/PublicWorksEquipLightingVisibility.pdf>.

- 2.3 It will be the responsibility of the Bidder to inform the City of any deficiencies in these specifications, for under this Contract the Contractor shall be held responsible for the design, performance, reliability and satisfactory operational function of the units.

#### **3.0 SERVICE FACILITY**

- 3.1 For the purpose of warranty repairs, the Bidder shall have an authorized service facility located within 10 km of the boundaries of the City of Winnipeg. The facility, or a portion thereof, shall be dedicated to the service and maintenance of the type equipment being offered. Further to B9.1, Bidders shall provide a description of the service facility including, but not limited to, number of qualified service staff, years of service experience, and general service capabilities within three (3) Business Days upon request of the Contract Administrator.

#### **4.0 REFERENCES**

- 4.1 Provide five (5) Canadian references where this equipment is used in a working environment where climatic conditions are similar to the City of Winnipeg.

---

---

---

---

---

#### **5.0 MAKE & MODEL**

- 5.1 **State** make and model of the equipment bid- \_\_\_\_\_

#### **6.0 INSTRUCTIONS FOR COMPLETION OF SPECIFICATIONS**

- 6.1 Each bid will be evaluated based on adherence to all terms, conditions and requirements outlined in the Bid Opportunity package.

- 6.2 All items in these specifications must be answered indicating compliance or non-compliance. **BIDDERS SHALL STATE "YES" FOR COMPLIANCE OR STATE DEVIATION**, or give reply where requested to do so. Deviations shall be clearly stated and fully detailed. Alternatives will be considered subject to evaluation.

- 6.3 **EACH BIDDER IS REQUIRED TO FILL IN EVERY BLANK. FAILURE TO DO SO MAY BE USED AS A BASIS FOR REJECTION OF BID**

#### **7.0 PERFORMANCE RELIABILITY**

- 7.1 The responsibility for the design of the **Specialized Utility Vehicle**, its performance and reliability shall rest upon the Contractor.

- 7.2 The term "repeated failures" as used herein is defined to mean that the same component, subassembly, or assembly develops repeated defects, breakdowns and/or malfunctions rendering the vehicle inoperative, or requiring repeated shop correction, service and/or replacement during the warranty period applicable for said component, subassembly, of assembly. Minor items or ordinary service adjustments are not included, or considered under the scope of "repeated failures", as well as other factors, such as operational damage due to accidents, misuse or lack of proper maintenance, service and lubrication attention by not following the manufacturer's preventative maintenance schedule.

- 7.3 Where the **Specialized Utility Vehicle** develops "repeated failures" in service, the Contractor shall make any necessary engineering changes, repairs, alterations or modifications in order to guarantee reliability of performance.

- 7.4 The equipment shall be capable of consistent top performance in City of Winnipeg Environment. Note: The City of Winnipeg has four seasons with ambient temperatures ranging from approximately 90°F (32°C) to -40°F (-40°C)

#### **8.0 FUEL**

- 8.1 Where applicable, all equipment must be fully fuelled upon delivery (no exceptions).

#### **9.0 QUALIFICATIONS OF MANUFACTURER & CONTRACTOR**

- 9.1 The manufacturer of the **Specialized Utility Vehicle** shall have five (5) years continuous experience manufacturing the equipment.

- 9.2 The manufacturer shall have in effect a documented quality control program ensuring that the quality of materials and workmanship, including welding, conforms to the best standards and engineering practice of the industry.
- 9.3 The Contractor shall have five (5) years continuous experience servicing, repairing and maintaining **Specialized Utility Vehicle** of the type being offered.

10.0 **SPECIFICATIONS:**

10.1	Engine	Diesel rated at 60-65 hp. Cold engine starting will be aided by glow plugs. Control of the glow plugs will be automatic based on engine temperature. Emissions Tier IV Diesel Interim or Final.	_____
10.2	Machine to include a front loader	Lift arm with double acting hydraulic cylinders. Loader Rated Operating Capacity of 1500 lbs. Loader functions controlled by a single pilot-operated hydraulic joystick. Lift-arm "float" feature must be provided and activated by the hydraulic joystick. Loader arm and all attachments must meet all applicable SAE safety standards.	_____
10.3	Seats	Forward facing –operator and passenger	_____
10.4	Front loader	Capable of accepting quick-attach attachments	_____
10.5	Rear cargo box	Cargo box load capacity of 2000 lbs. Hydraulic dump provided by two hydraulic cylinders, and activated by a cab mounted control. An approved cargo box support device is required on the machine to mechanically support the box if raised for service work. Box sides are bolt-on and can be removed to make a flat-bed. A tailgate is provided which includes a quick-latch system, and is capable of supporting at least 300 lbs. of load in the open position. Stake pockets to be provided on the sides and front of the cargo box. Cargo box must meet all applicable SAE safety standards.	_____
10.6	Cargo box liner	Spray in box liner	_____
10.7	Drivetrain	Full-time four wheel drive system	_____
10.8	Differentials front and rear	Limited slip differentials for both axles	_____
10.9	Transmission	Hydrostatic	_____
10.10	Engine and travel speed	Equipped with separate controls for engine speed and travel speed	_____
10.11	Drive speed	Controlled by a single pedal	_____

10.12	Engine RPM control	Controlled by hand lever	_____
10.13	Neutral start feature	A neutral start feature which requires machine be in the "Park" position (parking brake applied) before engine can be started	_____
10.14	Two travel speeds ranges	High and low ranges	_____
10.15	Shift on-the-fly	Ability to shift between travel speed ranges while moving	_____
10.16	Low range travel speed	Variable from 0 to 9 mph	_____
10.17	High range travel speed	Variable from 0 to 18 mph	_____
10.18	Reverse travel speed	Limited to 9 mph	_____
10.19	Cruise control	Preferred	_____
10.20	Crab steering	4 wheel steering	_____
10.21	Tires, 2 sets	Each unit to be delivered with turf tires installed. Also include standard tires mounted on rims.	_____
		The Standard Tire: State Size_____	_____
		The Turf Tire: State Size_____	_____
	<b><u>CAB</u></b>		_____
10.22	Windows	Front and rear windows, made from tempered safety glass	_____
10.23	Windshield wipers	Dual-arm front windshield wipers provided with a windshield washer system	_____
10.24	12 volt power outlet	for accessories provided in the cab	_____
10.25	HVAC System	Heating, ventilation, and air conditioning	_____
10.26	Interior lighting and cup holders	Interior dome light, two cup / beverage holders	_____
10.27	Cab enclosure	Consists of two steel frame doors with locking handles	_____
10.28	Work lights	Four halogen work lights provided on the front which can be positioned independently of each other	_____
10.29	Cab structure	4-post design which is ROPS and FOPS approved per SAE and ISO standards. Retractable seat belts for the operator and passenger, and incorporate a 3-point design which includes a shoulder restraint per SAE J2292.	_____

10.30	Radio	AM/FM radio/CD player or MP3 player with Bluetooth if available, <b>state</b>	_____
10.31	Instrument panel	Gauges-engine temperature and fuel level. Gauges are to be back-lit when the front lights are on. Digital display required display all of the following: Travel Speed (in both mph and km/h), Engine RPM, Engine Hours, and Job Hours (resettable). Display to be back-lit when front lights are on. Warning lights provided to indicate all of the following: Low engine oil pressure, Low fuel level, Low battery voltage, High hydraulic temperature, and High engine temperature. An engine and hydraulic systems monitor will be provided to monitor vital machine conditions.	_____
10.32	Automatic engine shutdown	The engine automatically shuts-down in the event vital conditions exceed acceptable limits. The engine needs the ability to restart in 30 second intervals to move the machine after shut-down occurs.	_____
10.33	Service diagnostic capabilities	The systems monitor will also display a code when warning conditions are encountered, and store these codes for later access.	_____
10.34	Brakes loading	Shared by all wheels. The machine automatically brings itself to a stop when the drive pedal is released.	_____
10.35	Parking brake	Parking brakes equipped in each axle, engaged by mechanical spring force, and released by hydraulic pressure. Drive controls automatically deactivate when the parking brake is applied. The parking brake to engage automatically when the engine is not running.	_____
10.36	Safety	An interlock control system to be provided which automatically disables the loader lift, loader tilt, attachment hydraulics, drive controls, and engages the parking brake when the operator exits the machine. Fire extinguisher 2.5 lb. ABC type, securely mounted and secured, quick release. Slow moving triangle vehicle sign and bracket attached to rear of vehicle.	_____
10.37	Safety lighting	Make and Model Whelen Responder LP (RDLPPAB) Amber/Blue DUO Permanent Mount (LED Mini Light bar) wired directly to the ignition, mounted on top on the cab driver's side (See Appendix A).	_____



**HYDRAULICS and  
TOWING**

10.38	Attachments	To be front mounted. Connections for all attachments to be Quick Attach compatible, and meet SAE J2513 for coupling of attachments.	_____
10.39	Quick hitch	Activation of quick-hitch provided by two over-center locking levers with wear.	_____
10.40	Hydraulic connections	Supplied via hydraulic quick-couplers with a flush-face design	_____
10.41	Hydraulic supply	To attachments "high flow" approx. of 25-30 gpm	_____
10.42	Hydraulic pressure release system	To relieve residual pressure trapped in the attachment hydraulics for safe attachment changes	_____
10.43	Primary attachment hydraulics	Primary attachment hydraulics activated by switches integrated into the loader joystick and ability to lock into continuous flow (detent) in both forward and reverse directions.	_____
10.44	Rear receiver hitch	A rear receiver hitch system will be provided which is capable of accepting 2-inch receiver-style hitches, and meets the "Hitch Strength Requirements".	_____
10.45	Rear remote hydraulics	Supplied via hydraulic quick-couplers with a flush-face design	_____
10.46	Towing capacity	Capable of withstanding 500 lbs. of tongue load and capable of pulling and stopping tow loads of 4,000 lbs.	_____

**OPERATOR STATION  
ERGONOMICS**

- 10.47 Cab or station layout should provide a comfortable seating position for the 5<sup>th</sup> to the 95<sup>th</sup> percentile of personnel. Figure 1 below illustrates the variance between a 5<sup>th</sup> to a 95<sup>th</sup> percentile of North American males and females when seated.

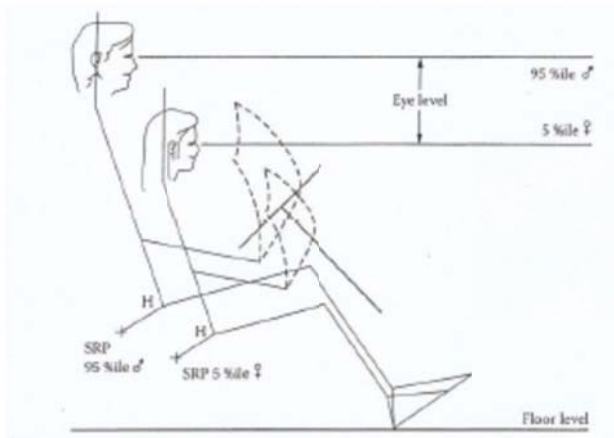

10.48 Figure 2: Use the below diagram to answer the specifications for Operator Station Ergonomics.

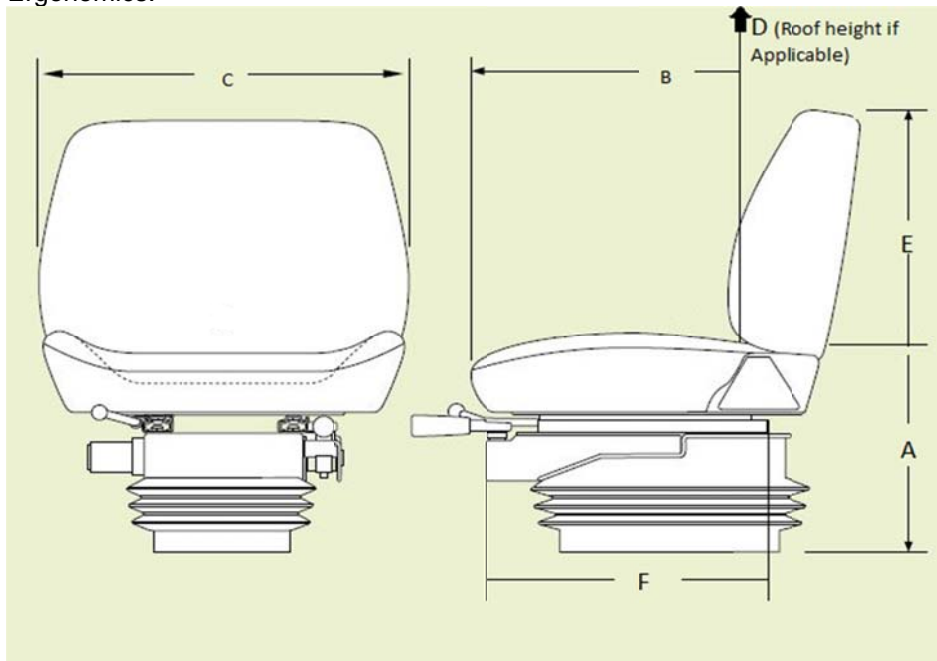

- |       |                                                                                        |                                            |       |
|-------|----------------------------------------------------------------------------------------|--------------------------------------------|-------|
| 10.49 | Sitting height range from floor (where feet rest) (A)                                  | <b>State</b> , seat height range in inches | _____ |
| 10.50 | Seat length/depth (B)                                                                  | <b>State</b> , seat length/depth in inches | _____ |
| 10.51 | Seat width (C)                                                                         | <b>State</b> , seat width in inches        | _____ |
| 10.52 | Cab height from seat to roof (if applicable) (D)                                       | <b>State</b> , cab height range in inches  | _____ |
| 10.53 | Back rest height (E)                                                                   | <b>State</b> , back rest height in inches  | _____ |
| 10.54 | Seat travel range (F)                                                                  | <b>State</b> , seat travel in inches       | _____ |
| 10.55 | Include any other relevant ergonomic specifications and applicable range of adjustment |                                            | _____ |

## **ATTACHMENTS**

Note: Options to be priced only as indicated on Form B: Prices.

### **Option 1: One unit to have the following attachments**

10.56	Front mount angle broom with pickup pan	Width approx. 60 inches	_____
10.57	Front mount high flow snow blower	Width approx. 60 inches	_____
10.58	Front mount low profile bucket w edge	Width approx. 62 inches	_____
10.59	Front mount mower deck	Width approx. 90 inches	_____

### **Option 2: Other unit to have the following attachments**

10.60	Front mount angle broom	Width approx. 68 inches	_____
10.61	Front mount high flow snow blower	Width approx. 60 inches	_____
10.62	Front mount 4-in-1 combination (clam) bucket	Width approx. 68 inches	_____
10.63	Front mount mower deck	Width approx. 90 inches	_____

## 11.0 **WARRANTY**

- 11.1 All warranty information shall be detailed and include all exclusions. The successful bidder shall provide all published warranty information upon delivery of the equipment. Bidder shall state all warranty information. \_\_\_\_\_
- 11.2 The warranty for the Specialized Utility Vehicle shall cover the complete equipment, and all parts thereof against any defects of workmanship, construction and materials, for a period of 12 months Any article that has become defective during said warranty period and has not proven to have been caused by negligence on the part of the user shall be repaired or replaced at no cost to the City. The warranty shall be effective from the date the equipment is put into service by the City of Winnipeg. Please provide complete warranty details with the bid submission \_\_\_\_\_

## 12.0 **DELIVERY**

- 12.1 Delivery Point: The complete unit shall be serviced, ready for operation and delivered F.O.B. with the freight prepaid, including invoice and N.I.V.S. (if applicable) to the WFMA 185 Tecumseh Street, Winnipeg MB. The successful bidder shall be notified by the Contractor Administrator the delivery address prior to issuance of the purchase order \_\_\_\_\_
- 12.2 Delivery Time: **Four to six (4-6) calendar weeks** from the date of award. Equipment shall be delivered between 8:00 am and 3:00 pm on Business Days. \_\_\_\_\_

12.3 Delivery Contact: The Contractor shall contact the Contract Administrator prior to delivery of the equipment. \_\_\_\_\_

12.4 P.D.I: A pre-delivery inspection shall be performed by the Contractor on the equipment. Proof upon inspection including completed check list \_\_\_\_\_

13.0 **MANUALS**

13.1 Manuals supplied under this contract. The manuals shall cover the complete equipment including all components thereof, CD is preferred where available. \_\_\_\_\_

13.2 The following manuals shall be supplied with the units when delivered:

a) Operator's manual – Two (2) per unit (one operator manual shall be sent to the Equipment Operator Training Branch \_\_\_\_\_

b) Parts and service manuals – one (1) complete sets including preventative maintenance schedules. CDs are preferred. \_\_\_\_\_