

A1 SIZE - 594mm x 841mm

© CH2M HILL 2015. ALL RIGHTS RESERVED.

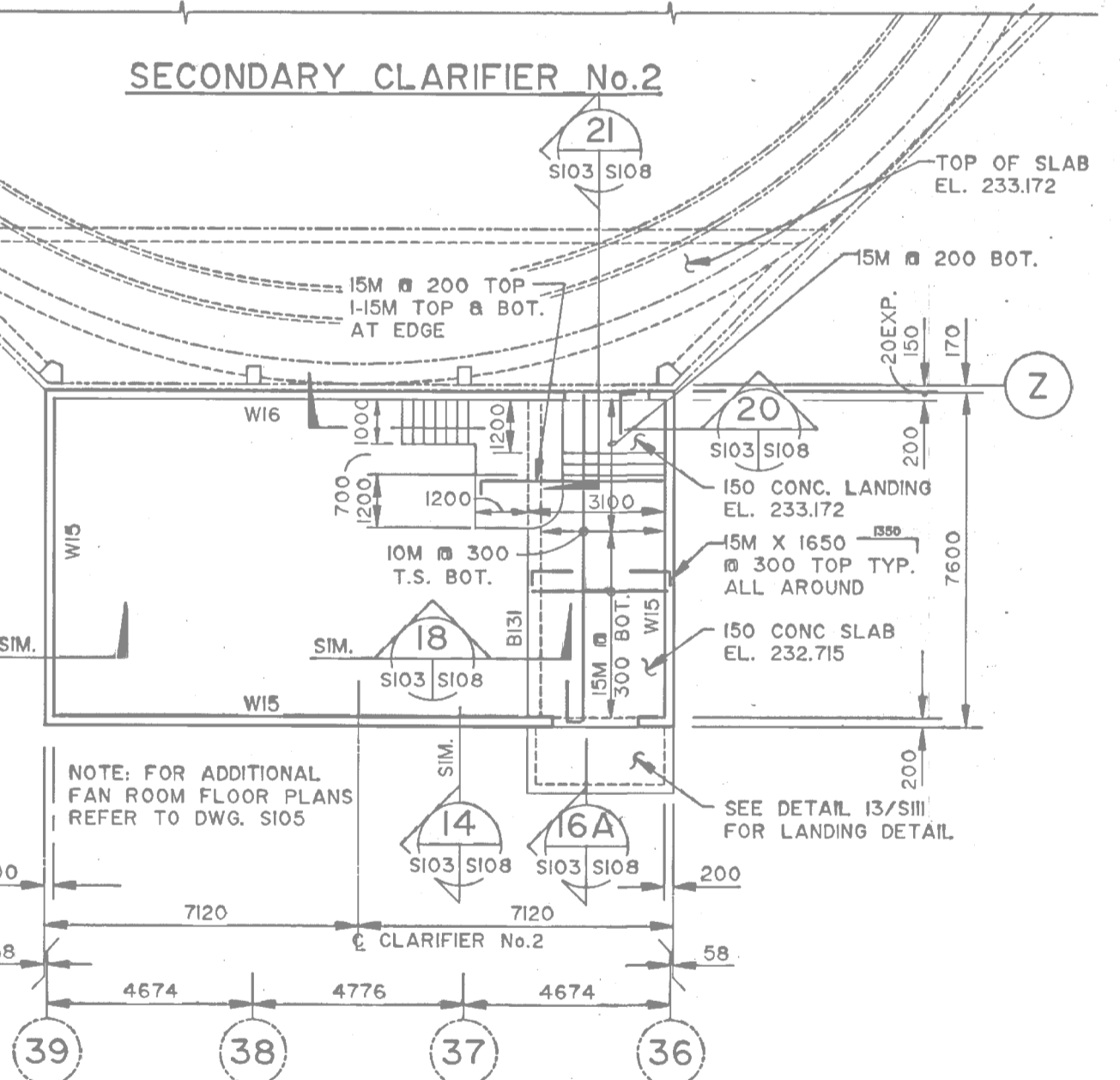
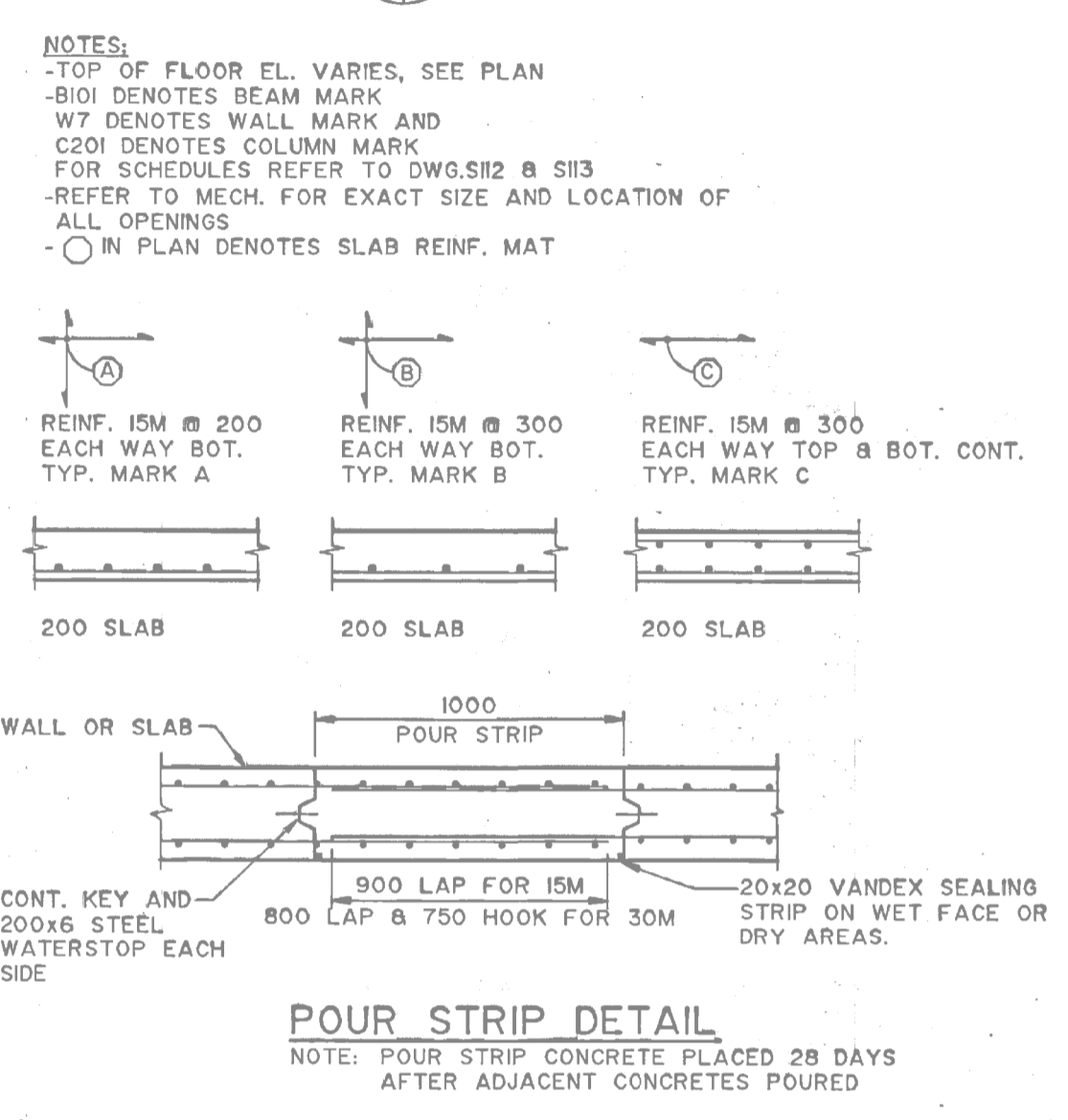
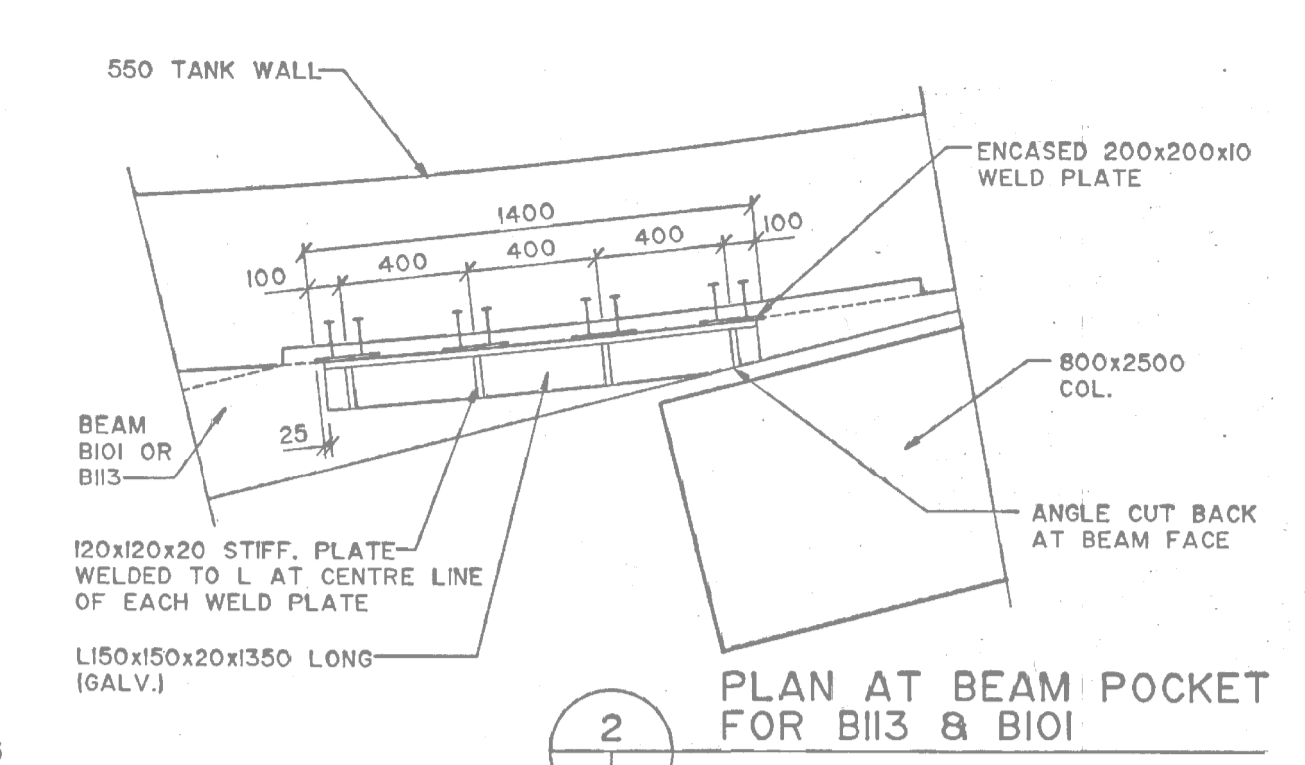
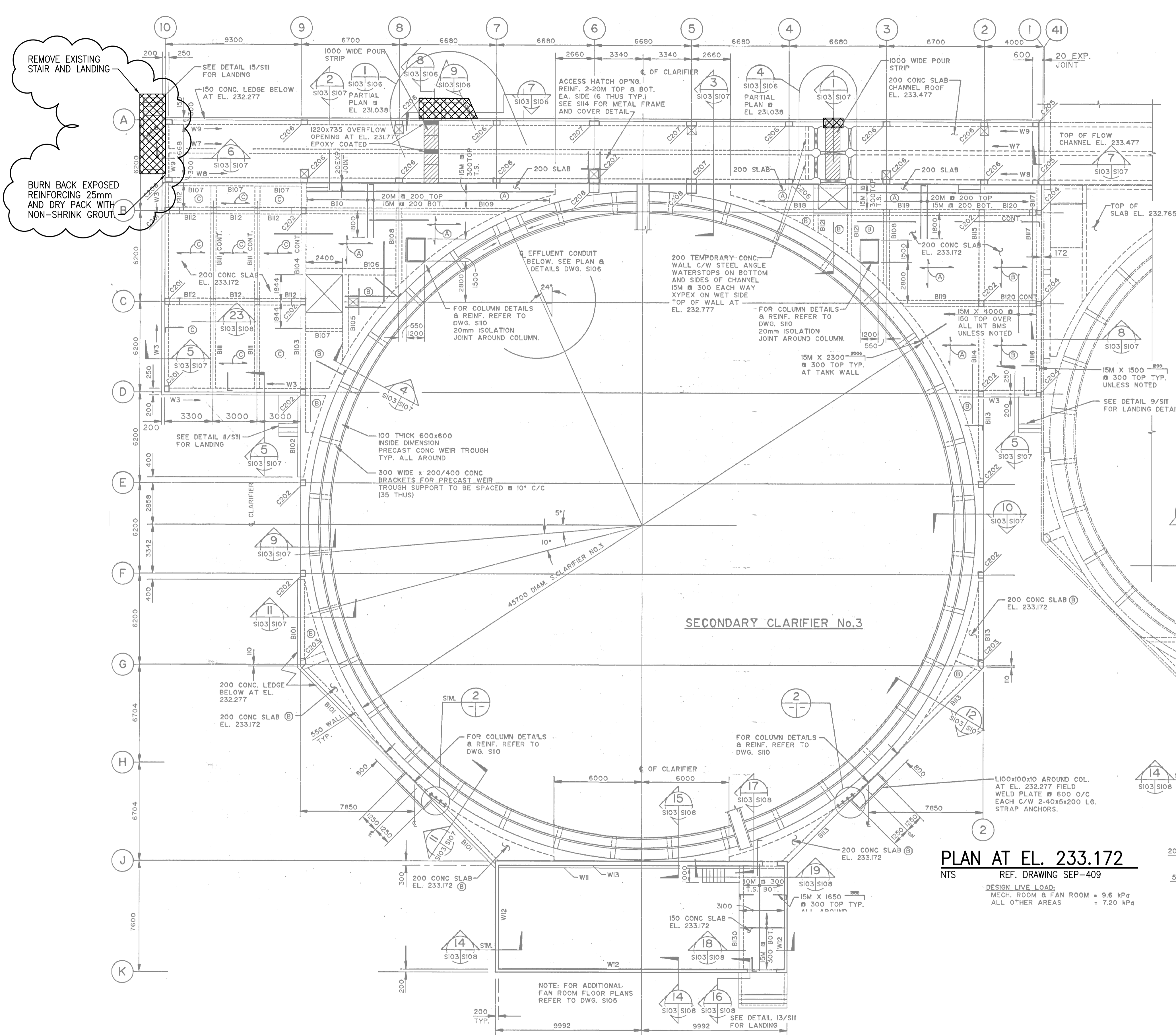

**PLAN AT EL. 233.172**  
 NTS REF. DRAWING SEP-409  
 DESIGN LIVE LOAD:  
 MECH. ROOM & FAN ROOM = 9.6 kPa  
 ALL OTHER AREAS = 7.20 kPa

**NOTES:**  
 1. FOR NEW CONSTRUCTION SEE DRAWING 1-0102-DGAD-S002.  
 2. REFER TO GENERAL DEMOLITION NOTES DRAWING 4-0102-DGAD-A001.

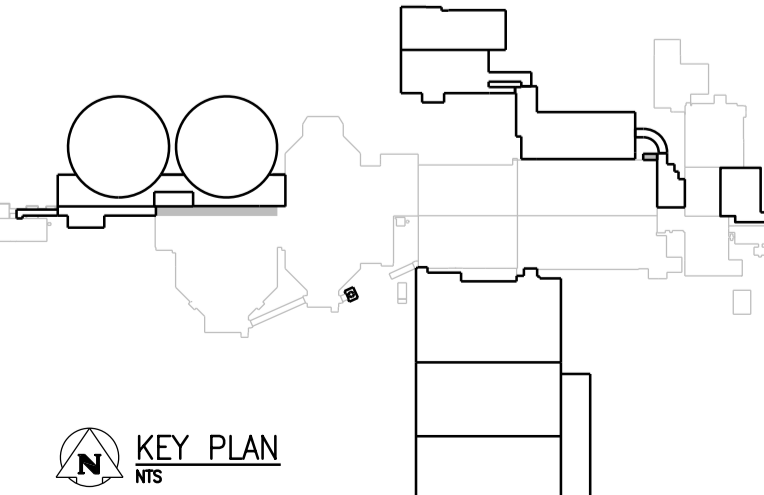

**APEGM**  
 Certificate of Authorization  
 CH2M HILL Canada Ltd.  
 No. 1441

NO.	REVISIONS	DATE	DESIGN	CHECK
00	ISSUED FOR TENDER - B.O. 899-2015	01/2016	G.G. J.C.	

PLOT DATE: 1/28/2016

**CH2MHILL**  
 SNC-LAVALIN  
 DESIGNED BY: E. LUJ  
 DRAWN BY: G. GERMAN  
 SCALE: NTS  
 DATE: 2014/01/17  
 CONSULTANT NO.: 474248

ENGINEER'S SEAL  
**KCS**  
 CHECKED BY: R. PARIKH  
 APPROVED BY: H.T. FREIHAMMER  
 ISSUED FOR CONSTRUCTION BY: T. TURZAK  
 DATE: 2016/01/29

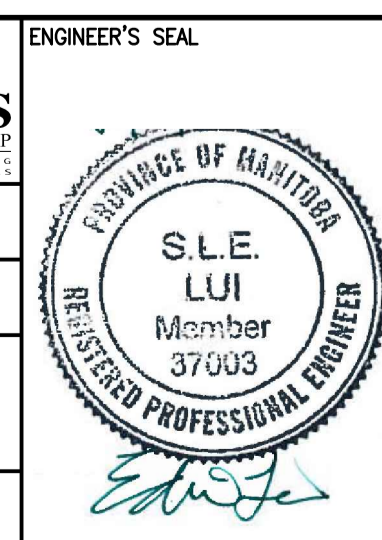

SEALING ARCHITECT OR ENGINEER ACCEPTS RESPONSIBILITY ONLY FOR AREAS IDENTIFIED BY CLOUDING ON THIS DRAWING.

NOTE: THIS DRAWING SUPERSEDES DRAWING SEP-409

**THE CITY OF WINNIPEG**  
 WATER AND WASTE DEPARTMENT

SOUTH END WATER POLLUTION CONTROL CENTRE  
 SEWPCC UPGRADING/EXPANSION PROJECT  
 STRUCTURAL  
 SECONDARY CLARIFIERS - CONCRETE AND CMU REMOVALS PLANS (2)

CITY DRAWING NUMBER: 1-0102-SGAD-S051  
 SHEET: 001  
 REV: 00  
 SIZE: A1

FILE NAME: 1-0102-SGAD-S051.dgn