

1 section detail
a503 1 1/2"=1'-0"

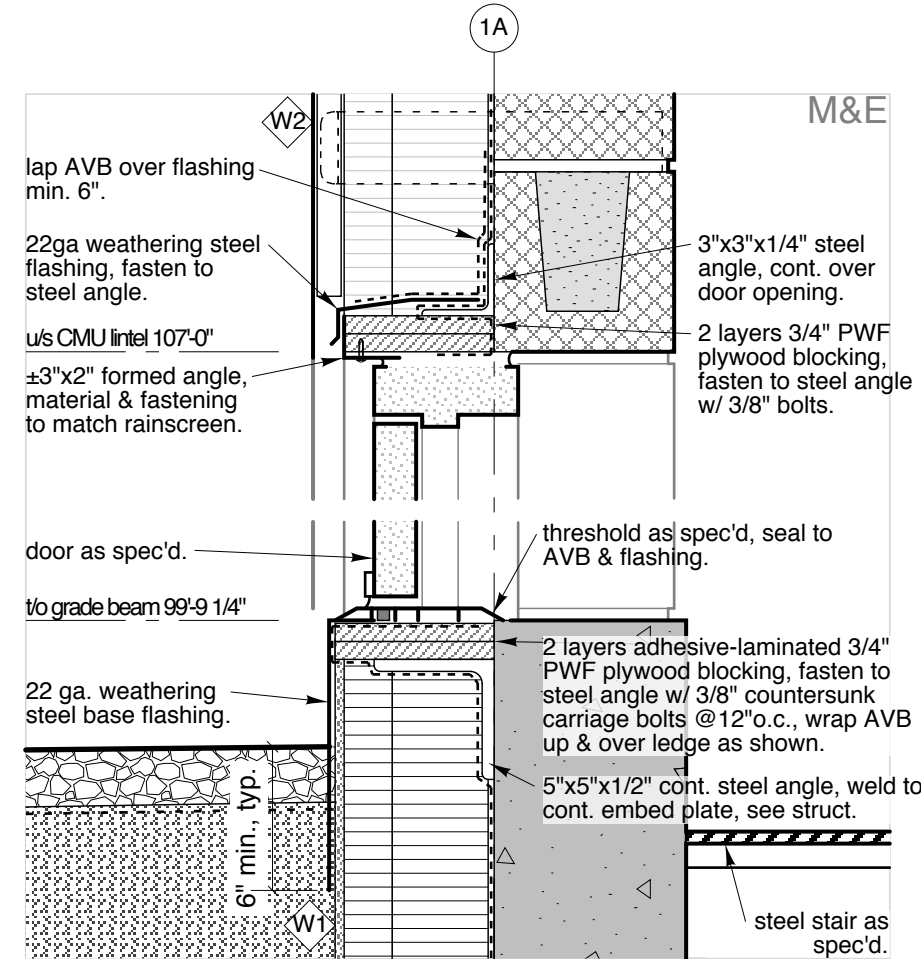

2 section detail
a503 1 1/2"=1'-0"

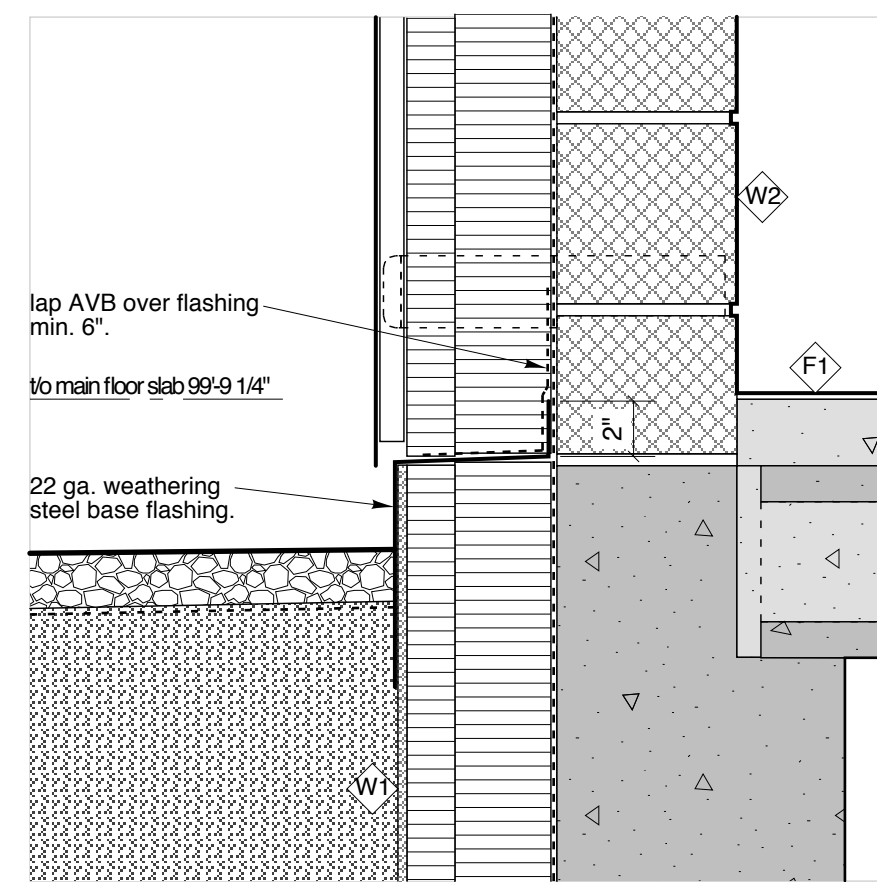

3 section detail
a503 1 1/2"=1'-0"

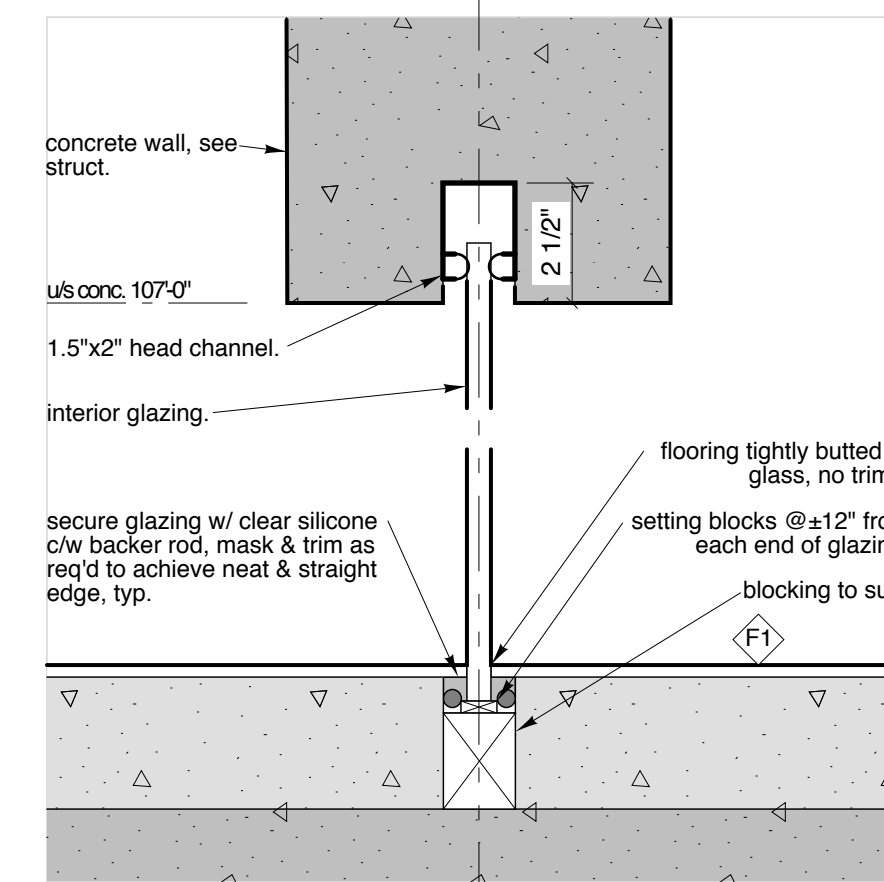

4 section detail
a503 3"=1'-0"

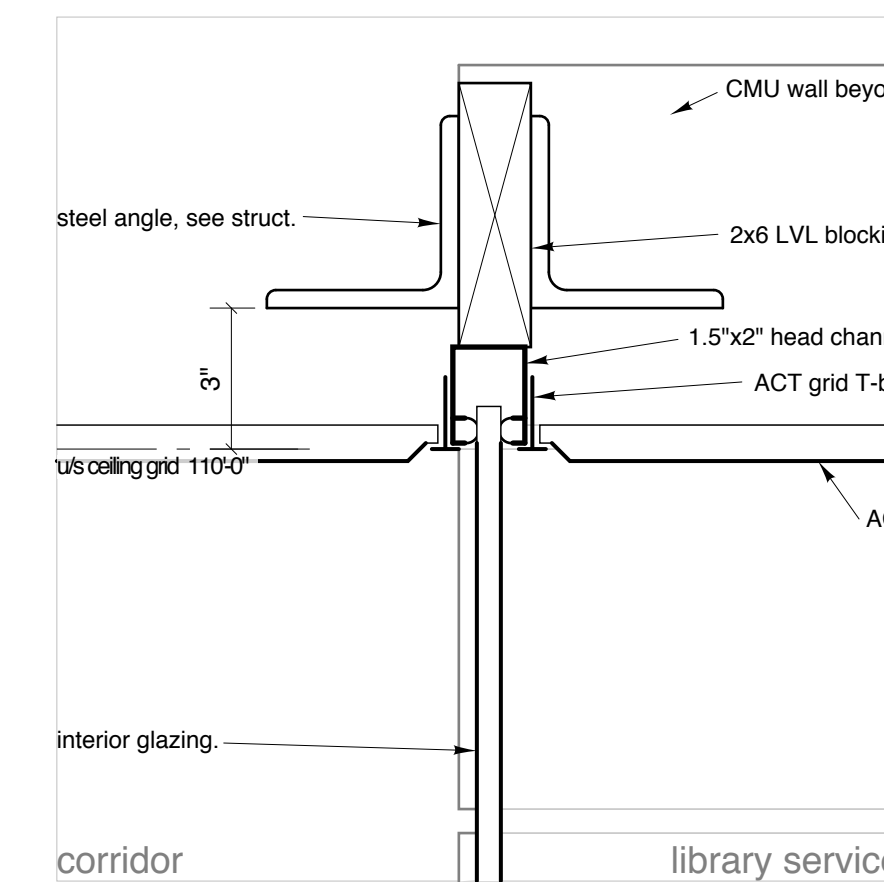

5 section detail
a503 3"=1'-0"

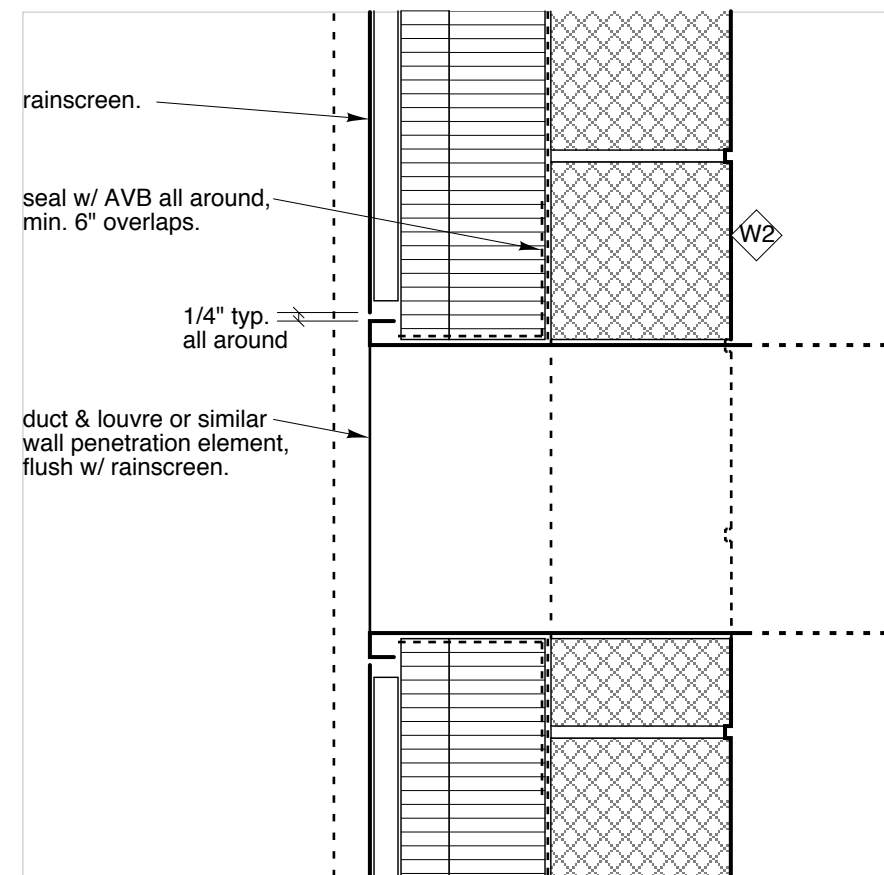

6 section detail
a503 1 1/2"=1'-0"

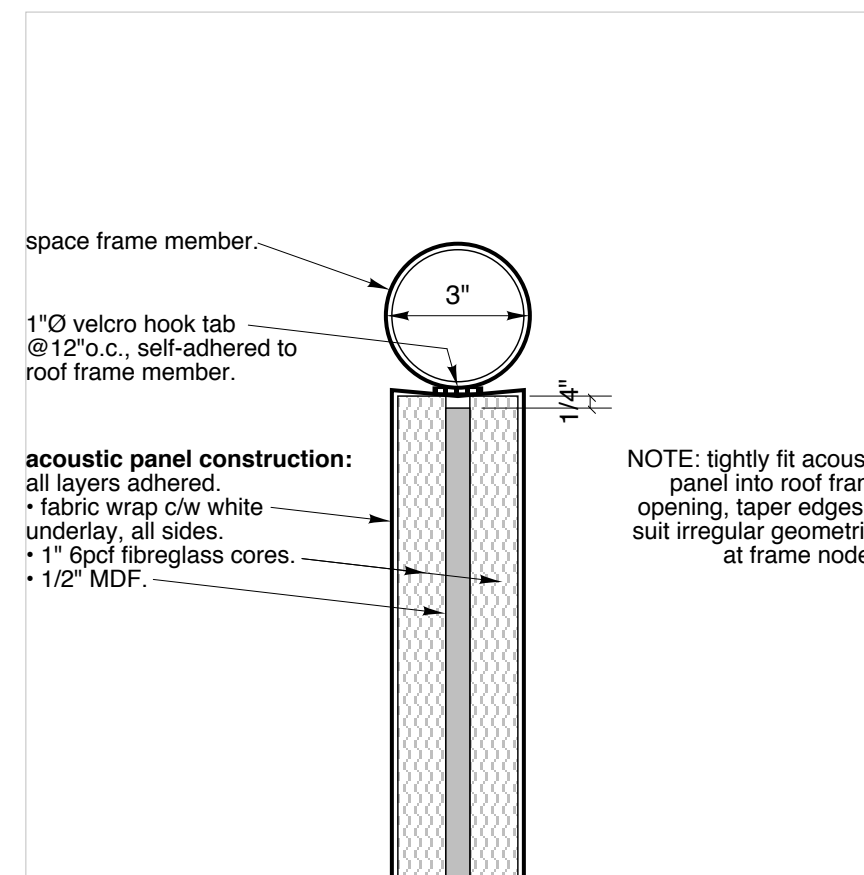

7 section detail
a503 3"=1'-0"

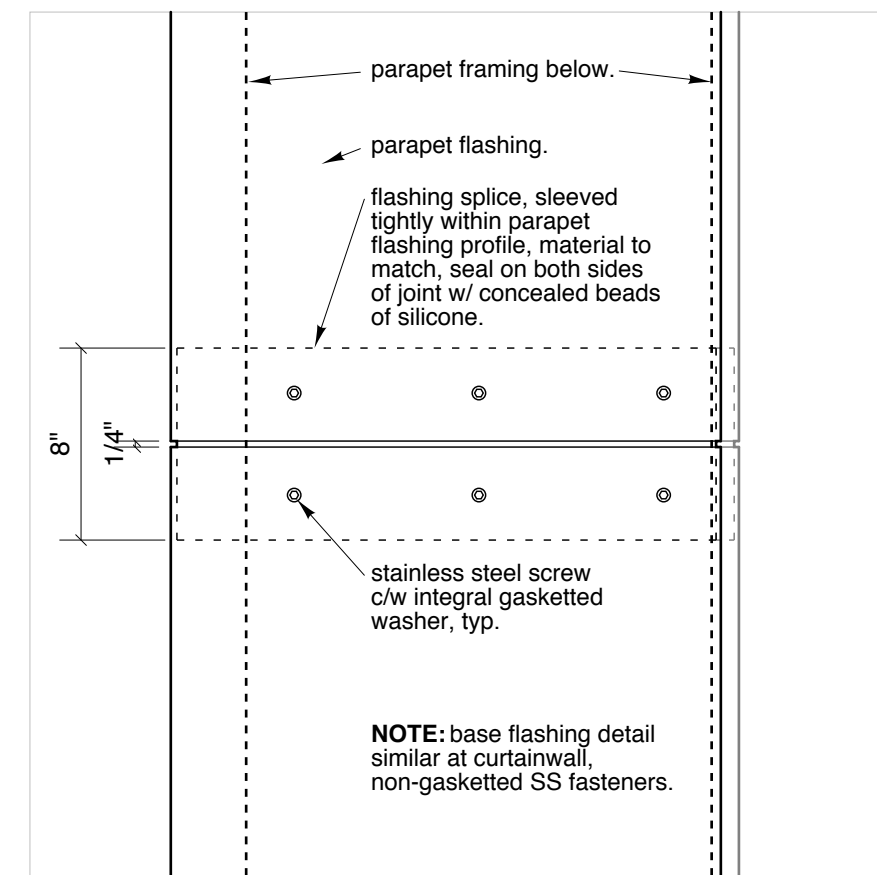

8 plan detail
a503 1 1/2"=1'-0"

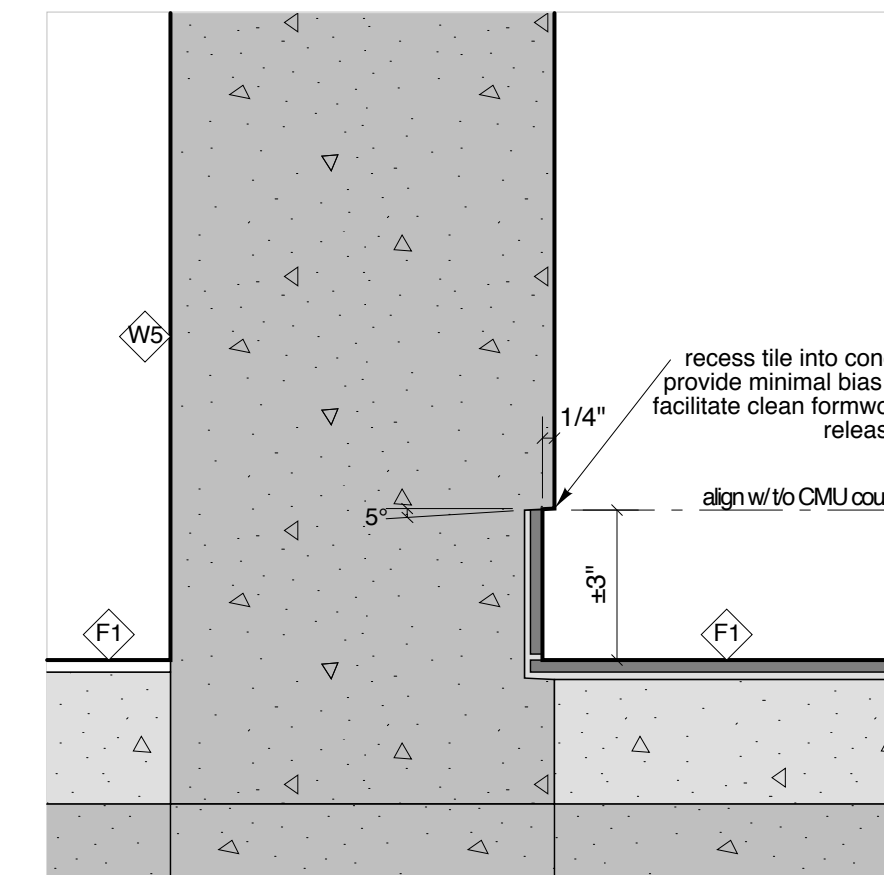

9 section detail
a503 3"=1'-0"

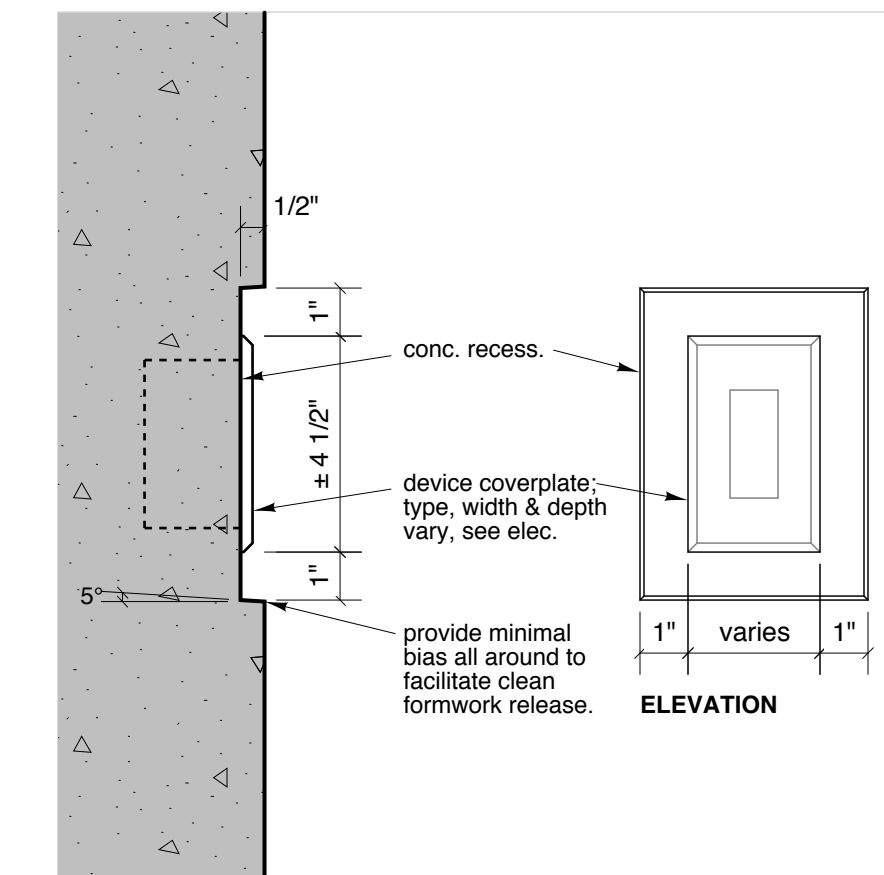

10 section detail
a503 3"=1'-0"

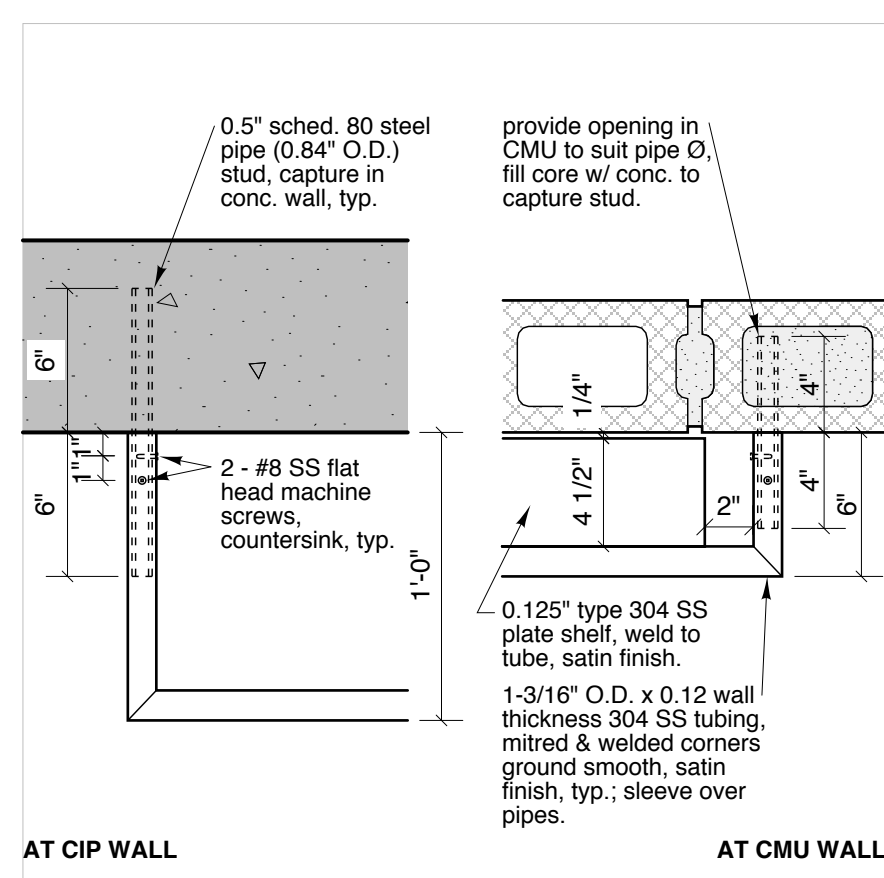

11 plan detail
a503 1 1/2"=1'-0"

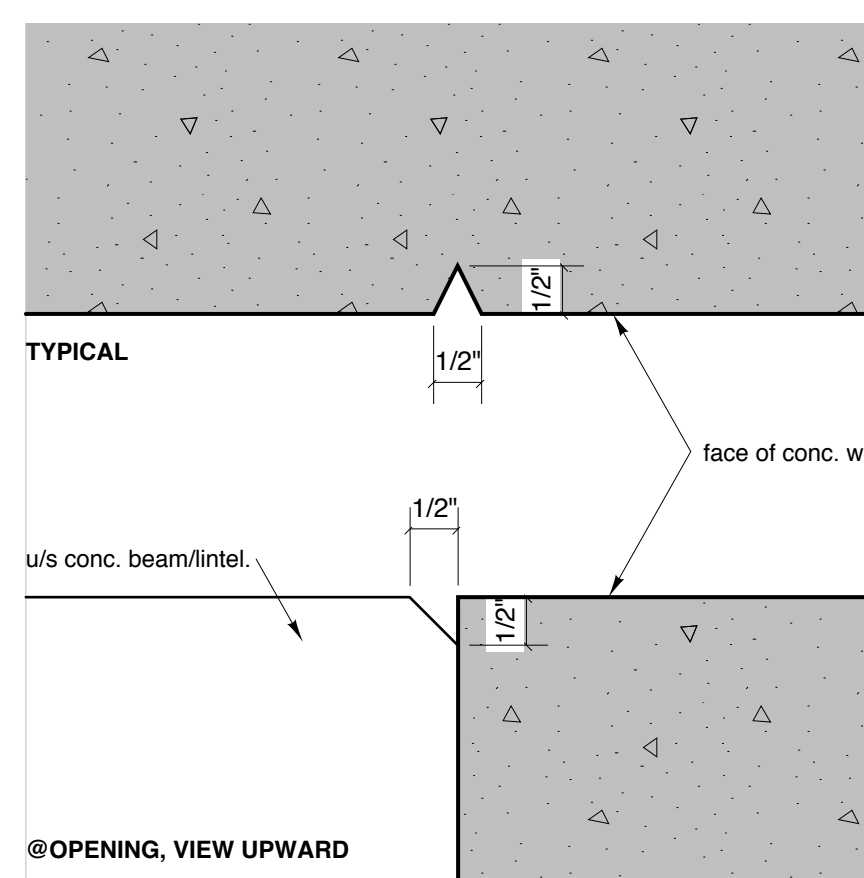

12 section detail
a503 6"=1'-0"

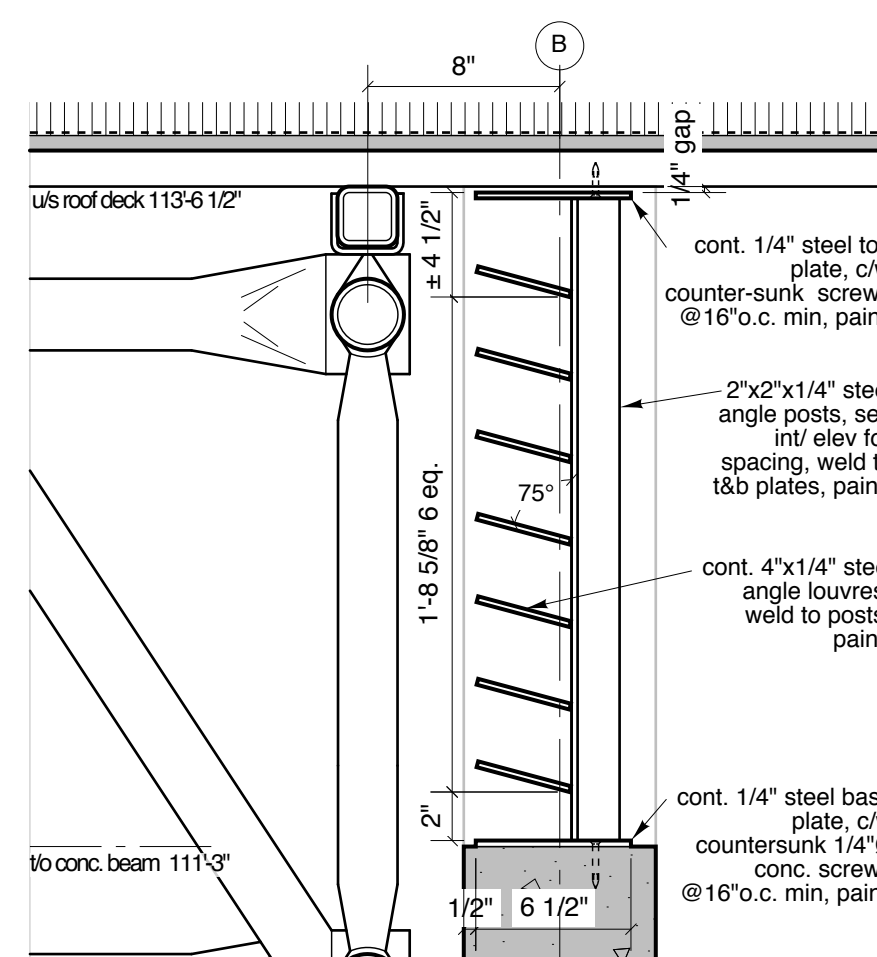

13 section detail
a503 1 1/2"=1'-0"

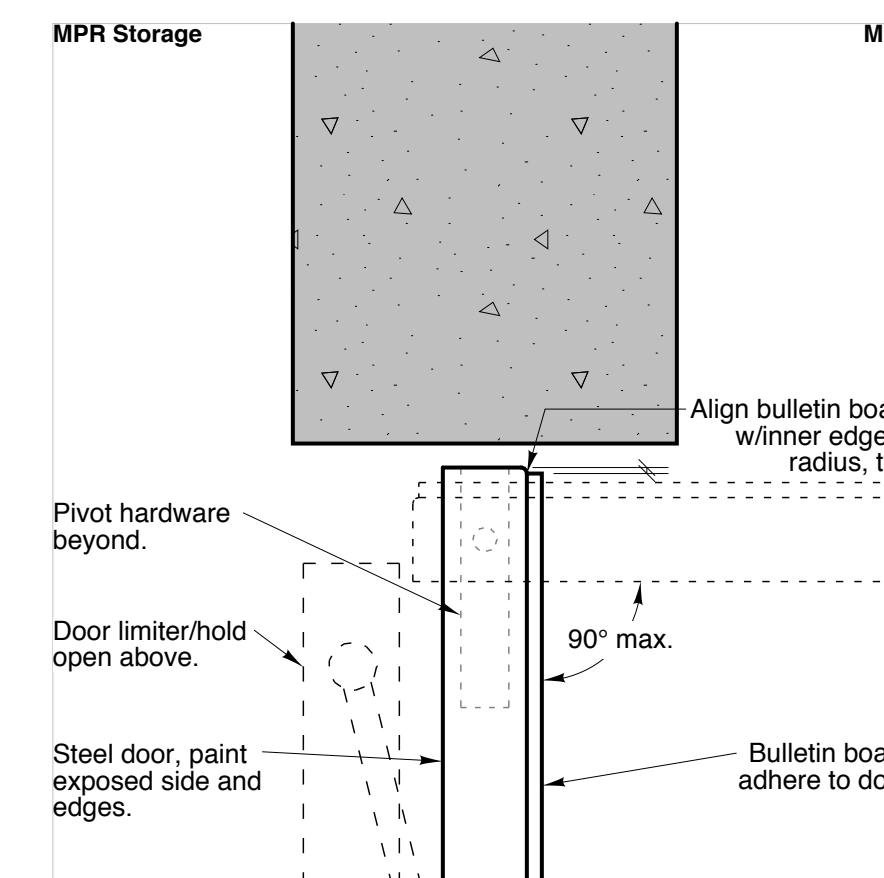

14 plan detail
a503 3"=1'-0"

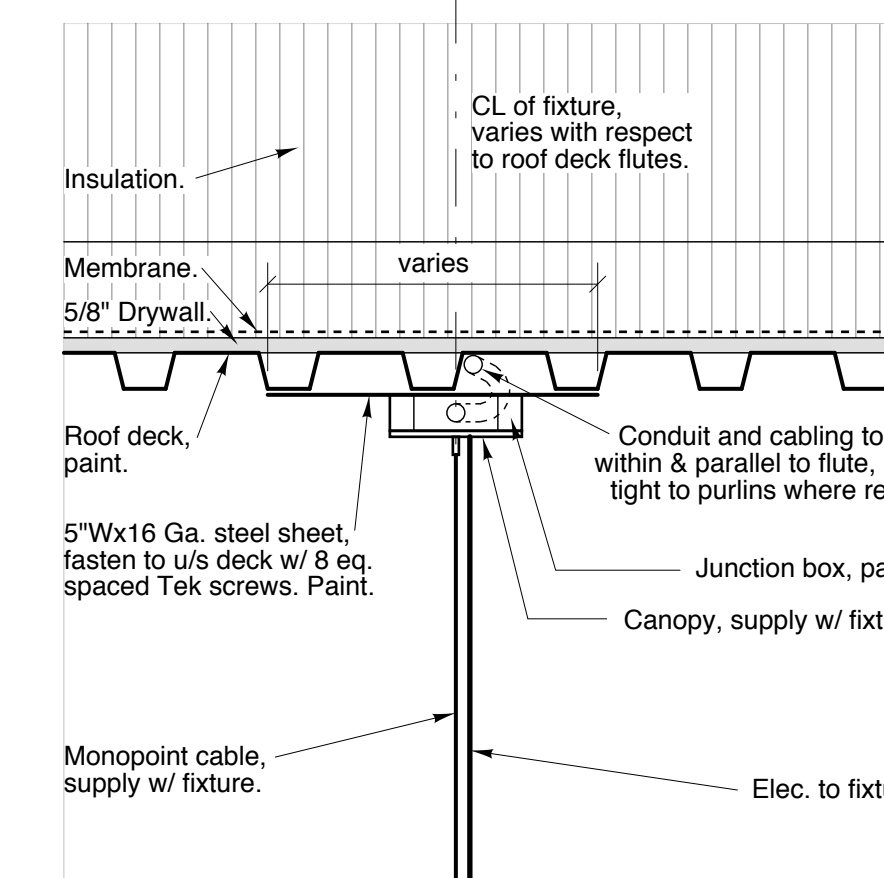

15 section detail
a503 1 1/2"=1'-0"

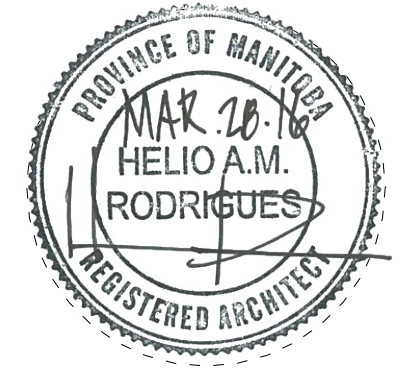

Issued for Construction: March 28, 2016

NOTES:
THIS DRAWING IS THE EXCLUSIVE PROPERTY OF HIS ARCHITECTURE AND DAVID PENNER ARCHITECT AND MAY NOT BE REPRODUCED AND/OR USED IN ANY MANNER WITHOUT THEIR EXPRESSED WRITTEN PERMISSION. THE GENERAL CONTRACTOR AND MATERIALS SUPPLIER'S SHALL CHECK ALL DIMENSIONS AND INFORMATION ON THIS DRAWING AND REPORT ANY DISCREPANCIES PRIOR TO COMMENCEMENT OF WORK. DO NOT SCALE THIS DRAWING.

OWNER
Winnipeg

CITY OF WINNIPEG - PLANNING, PROPERTY & DEVELOPMENT DEPARTMENT
MUNICIPAL ACCOMMODATIONS DIVISION
3rd FLOOR - 65 GARRY ST., WPG, R3C 4K4

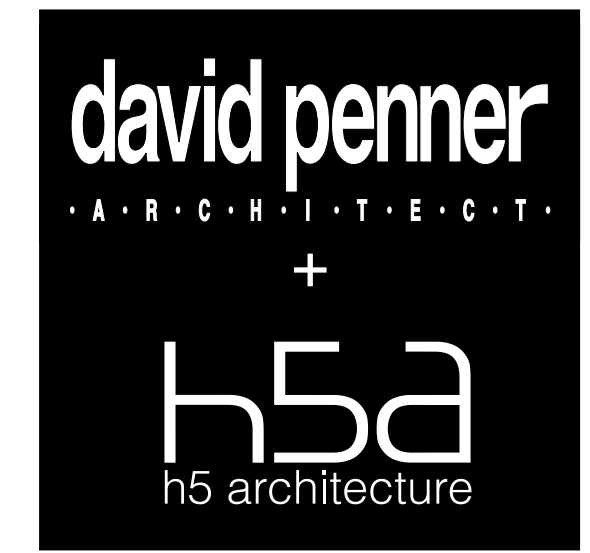

David Penner, 204.475.8978
Helio Rodrigues, 204.774.0012
120 Yale Avenue, Winnipeg, MB, R3M 0L7

PROJECT
Windsor Park Library
ADDRESS
1201 Archibald Street

DATE
March 28, 2016
SCALE
as noted

miscellaneous details
a.503