

TABLE OF CONTENTS

DIVISION 17

Section	Title	No. of Pages
17010	Instrumentation and Control General Requirements	16
17110	Enclosures	3
17124	Instrumentation Cable	3
17130	Power Supplies	2
17216	Switches and Relays	2
17271	Signal Conditioning Modules	1
17274	Panel Instruments	1
17275	Miscellaneous Panel Devices	2
17500	Control and Operator Interface Requirements	2
17600	PLC I/O Index	2
17700	Instrument Index	2
17701	Instrument Specification Sheets	4
17702	Instrument Loop Drawings	5

INSTRUMENTATION AND CONTROL GENERAL REQUIREMENTS

1. GENERAL

1.1 Requirements of Work

- .1 Supply, install, commission, provide warranty and fully document a complete I&C system as shown on the Drawings and as specified herein. The I&C system contains vendor component subsystems specified in this and other Sections of the Specification.
- .2 Component subsystems of the I&C system will include, but are not limited to, the following:
 - .1 Primary elements and transmitters.
 - .2 Final control elements.
 - .3 I&C field devices.
 - .4 I&C junction boxes and marshalling panels.
 - .5 Instrumentation cabling.
 - .6 Instrumentation power supplies.
 - .7 Conduit and cable tray.
- .3 The Contractor's responsibility also includes receiving, uncrating, examining for shortages or damage, assembling, field fitting, installing, mounting, wiring and testing of vendor supplied component subsystems.
- .4 Where packaged, stand-alone control systems are supplied under other Divisions of this Specification, provide cabling to connect to the required remote monitoring and/or control functions. Provide end-to-end Commissioning of all required remote monitoring and/or control functions. Ensure the correct functionality of any equipment supplied under other Divisions of this Specification.
- .5 Documentation referred to in 1.1.1 to include as a minimum:
 - .1 Equipment descriptive data.
 - .2 Equipment installation, service manuals, O&M Manuals and recommended spare parts lists.
 - .3 Schematics and interconnecting wiring diagrams.
 - .4 Records of conductor identification, field terminals, changes, etc.
 - .5 Instrumentation and control panel Shop Drawings, face layouts, schematics and point-to-point wiring diagrams.
 - .6 Records of as-built information for the complete instrumentation system.
- .6 Documentation provided is formatted as follows:

INSTRUMENTATION AND CONTROL GENERAL REQUIREMENTS

- .1 *Piping & Instrumentation Diagrams (P & IDS)* – depict the general intent of the control systems and are to be used as the governing document for the scope of Work.
 - .2 *Instrument Index* – an index of the detailed information for the devices shown on the P & IDS. The index lists the appropriate support documentation for the devices' supply and installation. The instrument index is the controlling document for the supply of materials.
 - .3 *Input/Output (I/O) Index* – an index of the control system I/O points shown on the P & IDS, giving the supporting documentation as per the instrument index.
 - .4 *Instrument Specification Sheets* – detail the relevant data for the supply of devices.
 - .5 *Instrument Loop Diagrams (ILDs)* – show typical interconnections and hook-up of devices. The Contractor is to reproduce an ILD for each device and record all relevant as-built information on each sheet for submission at the completion of the Work. Fill in all terminal and wiring numbers, etc., from the Shop Drawings as they become available. A set of 'B' size (11 x 17) ACAD Drawings and associated files will be made available to the successful tenderer. Where an ILD is not shown for wiring of simple devices provide a legible sketch for as-built information.
 - .6 *Location Drawings* – indicate in plan and/or elevation views where the instrument elements are physically located. These Drawings are provided to assist the Contractor in estimating the amount of cable and ducting required. All instrument locations specified on the location drawings are approximate. Exact locations will be determined during construction. Allow for locations to be up to 3 meters in each direction.
 - .7 *Standard Details* – provide a reference for installation, operation and other instructions pertinent to a particular device.
 - .8 *Detailed Specification* – lists qualifications, quality of materials and workmanship, and supplementary information.
- .7 Definitions
- .1 Interpret specialized terms not explicitly defined herein in accordance with ISA S51.1, NEMA ICS 1, ANSI/IEEE Std 100, and The Communications Standard Dictionary, by Martin H. Weik.
- .8 References
- .1 This Specification contains references to the latest available versions of the following Documents. They are a part of this Section as specified and modified. In case of conflict between the requirements of this Section and those of the listed Documents, the requirements of this Section prevail.

Reference

Title

API RP550

Manual on Installation of Refinery Instruments and Control Systems, Part I – Process Instrumentation and Control Sections 1 Through 13

ASME Section VII

Rules for Construction of Pressure Vessels

ASTM B68

Seamless Copper Tube

INSTRUMENTATION AND CONTROL GENERAL REQUIREMENTS

ASTM D883	Terms Relating to Plastics
IEEE 100	Dictionary of Electrical and Electronic Terms
ISA RP7.1	Pneumatic Control Circuit Pressure Test
ISA RP12.6	Installation of Intrinsically Safe Systems for Hazardous (Classified) Locations
ISA S5.4	Instrument Loop Diagrams
<u>Reference</u>	<u>Title</u>
ISA S18.1	Annunciator Sequences and Specifications
ISA S51.1	Process Instrumentation Terminology
NEMA 250	Enclosures for Industrial Controls and System
NEMA ICS 1	General Standards for Industrial Control and Systems
NEMA ICS 2	Industrial Control Devices, Controllers, and Assemblies
NFPA 70	NEC
SAMA PMC 17-10	Bushings and Wells for Temperature Sensing Elements
UBC	Uniform Building Code
UL 1012	Power Supplies
UL 94	Tests for Flammability of Plastic Materials for Parts in Devices and Appliances
Weik, Martin H.	Communications Standard Dictionary, Van Nostrand Reinhold Co.

.9 Related Work

.1 Process: Division 11.

.10 Qualifications

- .1 The instrumentation Subcontractor shall be a firm normally engaged and fully competent in the type of Work described in this Section of the Specification. The firm shall have been continuously and successfully engaged in this business for at least five years.
- .2 The instrumentation Subcontractor must be experienced in the process and instrument requirements of this Contract.
- .3 The instrumentation Subcontractor must show that it maintains a fully equipped and qualified organization, capable of performing the present Work and of providing warranty service to the system after installation.
- .4 Perform all instrument hook-ups, calibrations and checkouts with qualified journeyman instrument mechanics that are licenced and have CET registration. Instrument mechanics must be familiar with the devices being installed.
- .5 Perform all control wiring installation and connections with qualified journeyman electricians.

INSTRUMENTATION AND CONTROL GENERAL REQUIREMENTS

- .11 Codes, Rules, Permits and Fees
 - .1 Comply with all laws, ordinances, rules, regulations, codes and orders of all authorities having jurisdiction relating to this Work.
 - .2 Comply with all rules of the Electrical Safety Act of the Province, CSA Standards, ULC and the applicable building codes, whether specifically shown on Drawings or not.
 - .3 Give all required notices, submit Drawings, obtain all permits, licenses and certificates and pay all fees required for this Work.
 - .4 Furnish a certificate of final inspection and approvals from an inspection authority to the Contract Administrator.
- .12 Standards of Workmanship
 - .1 Execute all Work in a manner, which will result in the completed installation presenting an acceptable appearance, to a level of quality defined in the general conditions of this Specification.
 - .2 Employ a competent supervisor and all necessary licensed tradesmen to complete the Work in the required time.
 - .3 Arrange and install products to fit properly into designated building spaces.
- .13 Unless otherwise specified or shown, install products in accordance with the recommendations and ratings of the product manufacturers.
 - .1 Supply and execute installation of all instrumentation control tubing in accordance with Division 17.
- .14 Contract Drawings and Specifications
 - .1 Refer to Division 1.
 - .2 Supply and install all items and accessories specified by the Drawings or the Specification in the quality and quantity required. Perform all operations as designated by the Specification according to the methods prescribed, complete with all necessary labour and incidentals.
 - .3 Treat any item or subject omitted from this Division's Specifications or Drawings, but which is mentioned or reasonably specified in other Divisions' Specifications or Drawings and pertains to the instrumentation and control system, as being integral to the overall system. Provide such specified items or subjects.
 - .4 Provide all minor items and Work not shown or specified but which are reasonably necessary to complete the Work.
 - .5 If discrepancies or omissions in the Drawings or Specifications are found, or if intent or meaning is not clear, consult the Contract Administrator for clarification before submitting Bid.

INSTRUMENTATION AND CONTROL GENERAL REQUIREMENTS

- .6 The responsibility to determine which Division provides various products and Work rests with the Contractor. Additional compensation will not be considered because of differences in interpretation of Specifications.

1.2 Equipment

- .1 Receiving, Storing, and Protection of Components During Construction
 - .1 Examine each component upon delivery to Site. Report all damage noted to the Contract Administrator prior to accepting or rejecting delivery. All instrumentation primary elements, control components, panels, etc., shall be placed in a secure, dry, heated storage building. Maintain the space temperature above 10°C and the space relative humidity below 50 percent.
 - .2 Perform a preliminary examination upon delivery to ensure that:
 - .1 All instrumentation and control components supplied for this project under this Section of the Specification comply with the requirements stated in the instrument Specification sheets.
 - .2 All instrumentation and control components supplied under other Sections of this Specification, to be connected to instrumentation and control components supplied under this Section of the Specification, comply with the requirements stated in the Contract Documents.
 - .3 Itemize all non-conformities noted above and forward them to the Contract Administrator. Any delays in construction resulting from the delivery to Site of non-conforming instrumentation and control components to be borne by the Contractor.
 - .4 Do not install primary elements or other sensitive equipment until construction is sufficiently completed to provide an "operating condition" environment. Notify the Contract Administrator prior to installing any equipment of this type.
 - .5 Ensure that covers where required are properly installed on all equipment. Provide all covers, padding, guards, etc., as required to guard any equipment against damage.
 - .6 Return all damaged equipment to the factory for total corrective repairs. If deemed necessary by the Contract Administrator, the damaged equipment shall be replaced with new product. The Contractor shall bear any costs due to construction delays resulting from the delay in delivery of acceptable equipment.

1.3 Documentation

- .1 Bid Submittals
 - .1 Submit a schedule within 30 days of award of Contract to the Contract Administrator showing projected ordering and delivery dates of all products to meet the required construction schedule. Provide all necessary information regarding ordering and delivery dates for whose delivery affects the construction schedule.
 - .2 Submit Shop Drawings for all products supplied by this Division. Submit Shop Drawings for review prior to delivery of any products or equipment to jobsite and sufficiently in advance to allow ample time for checking.

INSTRUMENTATION AND CONTROL GENERAL REQUIREMENTS

- .3 Contractor to review, modify, and approve the Shop Drawings prior to submitting Shop Drawings to the Contract Administrator for review. Contractor approval of a Drawing indicates the following:
 - .1 The Drawing has been checked by the person making the approval.
 - .2 The equipment or material complies in all respects with the requirements of the Specifications and Drawings.
 - .3 The quantities, if indicated on the Drawing, are correct.
 - .4 The physical dimensions of the components are such that they can be installed without interference with the building structure or other equipment, and that, after installation, there are sufficient clearances on all sides for maintenance, servicing and operation of the equipment.
 - .5 The points of attachment are clearly indicated, i.e., TOP, BOTTOM, SIDE, etc.
 - .6 The arrangement and location are properly oriented.
 - .7 The product is suitable for its intended use.
- .4 Stamp and sign the Shop Drawing to show approval, indicating the above has been complied with. If Contractor revisions are too extensive, return the submission to the supplier for revision, then repeat the Shop Drawing approval process before submitting them to the Contract Administrator.
- .5 Manufacture of products shall conform to Shop Drawings marked as reviewed by the Contract Administrator and returned to the Contractor.
- .6 Keep one (1) complete, maintained set of Shop Drawings at the jobsite during the construction period, record Site modifications.
- .7 Refer to Division 1 for further information on Shop Drawing submittals.
- .2 O&M Manuals
 - .1 Refer to Division 1 for general O&M manual submittal information.
 - .2 In addition to the requirements specified in Division 1, provide the following information:
 - .1 Table of Contents – Arrange contents sequentially by systems under Section numbers.
 - .2 Systems Descriptions – A brief synopsis of each system typed and inserted at the beginning of each section. Include sketches and diagrams where appropriate.
 - .3 Maintenance and operating instructions for all equipment and controls – These operating instructions need not be manufacturer's data but may be typewritten instructions in simple language to guide the City in the proper operation and maintenance of his installation.
 - .4 A copy of all wiring diagrams complete with wire coding.

INSTRUMENTATION AND CONTROL GENERAL REQUIREMENTS

- .5 Set of final reviewed Shop Drawings.
- .3 Record Drawings
 - .1 Maintain on-site a complete set of As-built Drawings as listed in Division 1 of this Specification.
 - .2 In addition to the requirements as stated in Division 1, record on the Drawings the following information:
 - .1 Mark all change orders, alterations or additions.
 - .2 Show all instrumentation cable and control tubing.
 - .3 Show all changes to the numbers and location of outlets, motors, panels and end devices that may occur during the course of the Work.
 - .3 Before requesting the Total Performance certificate make any necessary final corrections to the Drawings, sign each print as a certification of accuracy and deliver all sets to the Contract Administrator for approval.

2. PRODUCTS

2.1 General

- .1 Refer to the requirements of Division 1
- .2 Selected Products and Equivalent
 - .1 Provide products and materials that are new and free from all defects.
 - .2 Products and materials called for on the Drawings or in the Specifications by trade names, manufacturer's name and catalogue reference are those, which are to be used as the basis for the Bid.
 - .3 The design has been based on the use of the first named product, where applicable equivalent products are listed.
 - .4 Provide the products specified unless a proposal for an alternative or substitute product has been accepted by the Contract Administrator.
- .3 Review of Products
 - .1 Immediately after notification of award of Contract, review with the Contract Administrator the list of products to be provided by this Division.
 - .2 After agreement on product list has been reached, no subsequent changes will be permitted except as specified hereafter.
- .4 Substitution of Products After Contract Award
 - .1 After acceptance of the list of products, no substitution of any item will be permitted unless the approved item cannot be delivered in time to comply with the Work schedule.

INSTRUMENTATION AND CONTROL GENERAL REQUIREMENTS

- .2 To receive acceptance, proposed substitute products are to equal or exceed the quality, finish, and performance of those specified and/or shown, and not to exceed the physical space requirements allotted, as shown on the Drawings.
- .3 Provide to the Contract Administrator documentary proof of equality, difference in price (if any) and delivery dates, in the form of certified quotations from suppliers of both specified items and proposed substitutions.
- .4 Include costs for any required revisions to other structures and products to accommodate such substitutions.
- .5 Refer to Division 1 for additional information on substitutions.
- .5 Quality of Products
 - .1 All products provided to be CSA Approved, and Underwriters' Laboratories of Canada approved where applicable.
 - .2 If products specified are not CSA approved, obtain approval of the relevant provincial regulatory authority. Pay all applicable charges levied and make all modifications required for approval.
 - .3 Refer to Division 1 of this Specification for further information.
- .6 Uniformity of Manufacture
 - .1 Unless otherwise specifically called for in the Specification, uniformity of manufacture to be maintained for similar products throughout the Work.
- .7 Product Finishes
 - .1 Products to be manufacturers' standard finish.
- .8 Use of Products During Construction
 - .1 Any equipment used for temporary or construction purposes to be approved by the Contract Administrator and in accordance with Division 1 of this Specification. Clean and restore to "as new" condition all equipment prior to the time of Substantial Completion.
 - .2 The warranty period does not begin until the date of Substantial Completion of the Work.

2.2 Instrumentation

- .1 General
 - .1 Instruments to be suitable for the environmental conditions in which they are to be installed.
 - .2 Determine where injurious conditions may be expected to occur and make proper provision to protect the instruments to ensure their proper and reliable operation.

INSTRUMENTATION AND CONTROL GENERAL REQUIREMENTS

- .3 Provide power surge protectors, heating cables and devices to protect instruments, equipment and lines from being functionally impaired or damaged by power surges or environmental conditions such as moisture or freezing.

2.3 Identification

- .1 Provide lamacoid nameplates with 5 mm white lettering on black background. Identify the loop tag number (where applicable) and the device name, function, and instrument range or setpoint value on the nameplate.
- .2 Where it is not possible to attach a lamacoid nameplate to a field instrument component, provide the component with a stainless steel metal tag firmly wired to the device and identified with the loop tag number.
- .3 Identify all wires where they terminate at the marshalling panels, junction boxes and field devices with a heat shrink sleeve with machine printed labeling.
- .4 Clearly mark all panels, pull boxes, junction boxes, etc., to indicate the nature of service.
- .5 Provide neatly typed circuit directories for panel power distribution systems to indicate loops or devices powered by the circuit and the fuse size.
- .6 Identify all exposed control conduits at all pull box locations, where the conduits enter or leave a room, and 13 m on centre throughout the room. This shall apply to conduits above removable ceilings. Use Thomas & Betts TY-RAP 5532-M labels conduit identification.
- .7 For direct current wiring use black for positive and white for negative.
- .8 For thermistor wiring to motors use red and blue coloured, insulated wire.

2.4 Control Circuit Protection

- .1 All control circuits and I/O points shall be individually fused.
- .2 Protection parameters shall match what is currently installed on-site at the NEWPCC.

3. EXECUTION

3.1 Site Examination

- .1 Refer to the requirements of Division 1.
- .2 No additional compensation will be given for extra Work due to existing conditions that a Site examination prior to Bid should have disclosed.

3.2 Coordination With Other Divisions

- .1 Examine the Drawings and Specifications of all Divisions and become fully familiar with the Work. Before commencing Work, obtain a ruling from the Contract Administrator on any conflicting issues between Divisions. No compensation will be made for any costs arising from conflict not identified before Work has commenced.

INSTRUMENTATION AND CONTROL GENERAL REQUIREMENTS

- .2 Coordinate the Work to be performed under this Section of the Specification with all Divisions installing equipment to ensure that there are no conflicts.
- .3 Install anchors, bolts, pipe sleeves, hanger inserts, etc., required in ample time to prevent delays to other Division's installation Work.
- .4 Lay out the Work and equipment with due regard to architectural, structural and mechanical features. Architectural and structural Drawings take precedence over electrical Drawings regarding locations of walls, doors and equipment.
- .5 Structural members shall not be cut without prior approval of the Contract Administrator.
- .6 Examine previously constructed Work and notify the Contract Administrator of any conditions, which prejudice the proper completion of this Work.

3.3 Product Handling

- .1 Use all means necessary to protect the products included in this Division before, during and after installation, and to protect products and installed Work of all other trades.
- .2 Any damage to the products and/or installed Work shall be repaired or replaced by the Contractor at no additional cost to the City, and to the approval of the Contract Administrator.
- .3 Remove advertising labels from all products installed that have such labels attached. Identification or CSA labels are not to be removed.
- .4 Remove dirt, rubbish, grease, etc., resulting from Work performed under this Section of the Contract from all surfaces.

3.4 Separation of Services

- .1 Maintain separation between the electrical wiring system, building piping, ductwork, and the instrumentation cables so that each system is isolated (except at approved connections to such systems) to prevent galvanic corrosion. In particular, contact between dissimilar metals, such as copper and aluminum, in damp or wet locations is unacceptable.
- .2 Do not support wiring from pipes, ductwork, etc. Hangers for suspended ceilings are not to be used for the support of wiring.

3.5 Wire and Cable

- .1 Refer to Section 17124.

3.6 Equipment Connections

- .1 Prior to the connection of signal wiring to process control and instrumentation devices check the device voltage rating and polarity for compatibility with the corresponding loop and/or schematic diagram. Where device and circuit characteristics are found to be incompatible, the connections are not to be made. Report the condition immediately to the Contract Administrator.
- .2 All control-wiring diagrams illustrate typical control circuits applicable to the type of equipment specified. Control circuits may vary with different manufacturer's equipment.

INSTRUMENTATION AND CONTROL GENERAL REQUIREMENTS

Verify all control circuits with the suppliers of the equipment and make any corrections to the control wiring diagrams that may be required.

- .3 Provide power disconnect terminals in the marshalling panels for all devices or PLC/DCS input/outputs sourced from the panel. Provide local power disconnect switches for all 120 VAC power instruments. Mount adjacent to the instrument.
- .4 Provide a disconnecting means in the cable connecting each ultrasonic transponder to the transmitter. This disconnect shall consist of a terminal strip in a local WP junction box within approximately 3 m of cable from the transponder.

3.7 Wiring To Equipment Supplied By Others

- .1 Equipment supplied by the City or by other Divisions, that have external or field mounted control devices, are to be installed, wired and commissioned by this Division.

3.8 Access Panels

- .1 Provide access panels where instrumentation and control system junction boxes are concealed. Panels to be of adequate size for servicing of the concealed junction box and complete with necessary frames and hinged doors held closed with captive fasteners. The type and size of panels are to be coordinated with the Contract Administrator.
- .2 In removable ceiling areas provide markers on ceiling tile to locate equipment requiring access. Use a 25 mm diameter blue circle painted on the access panel to indicate that it is for instrumentation and control system access.

3.9 Instrument Mounting Stands

- .1 Supply and install instrumentation mounting stands as required. Stands are to be either floor or wall mounted. The mounting stands are to be fabricated from aluminum or galvanized steel.
- .2 Supply and install protective drip shields for any exterior stand-mounted instrumentation equipment. Drip shields are to extend 50 mm past the front and side faces of the equipment. Drip shields are to be fabricated from aluminum.

3.10 Sealing of Wall and Floor Openings

- .1 Seal all conduit and cable entries passing through outside walls of buildings, through partition walls separating electrical rooms from other areas, through fire separations, and through floors above grade.
- .2 Seal openings after all wiring entries have been completed.
- .3 Sealing material shall be fire resistant and shall not contain any compounds that could chemically affect the wiring jacket or insulating material. Cable penetrations through fire separations, if required, are to be sealed. Acceptable methods are Canstrut "Fire Stop", Electrovert "Multi-Cable Transit" or Dow Corning RTV Silicone Foam.

INSTRUMENTATION AND CONTROL GENERAL REQUIREMENTS

3.11 Sleeves

- .1 Provide sleeves of galvanized steel pipe with machine cut ends of ample size to accommodate conduits passing through walls, partitions, ceilings, floors, etc.
- .2 For walls, partitions and ceilings the ends shall be flush with the finish on both sides. For floors the ends shall extend 100 mm above finished floor level.
- .3 Fill the space between the sleeve and the conduit with fire stop material. Caulked around the top and bottom with approved permanently resilient, non-flammable and weatherproof silicone base compound. Ensure that the seal is compatible with the floor and ceiling finishes.
- .4 Locate the sleeves and position exactly prior to construction of the walls and floors.
- .5 Failure to comply with the above requirements shall be remedied at the Contractor's expense.

3.12 Testing of Instrumentation Loops

- .1 After all devices within a loop have been connected, check the loop for correct functioning and interaction with other loops, where applicable. Provide written notice to the Contract Administrator when the loops are going to be tested so that the tests may be witnessed at the Contract Administrator's discretion.
- .2 Check the operation of final control elements such as solenoid valves, actuators, etc., by manual control before checking with automatic control.
- .3 Test all tubing for leaks in compliance with ISA RP7.1 Isolate all instruments when tubing is being tested to protect against over pressure.
- .4 Perform tests and record results on test data forms, which are included in this Section. Develop additional and/or more detailed test forms as necessary to suit more complex instrumentation.
- .5 Sign and date all test reports. Submit the test reports to the Contract Administrator within five working days of testing.
- .6 Coordinate and cooperate with City staff, equipment suppliers, and other contractors to test Control system I/O points during loop testing.

3.13 Calibration

- .1 Instruments to be factory pre-calibrated and the calibration verified in-place after installation. Provide a printed record of the factory calibration parameters for "smart" devices.
- .2 Prior to calibration completely program all "smart" transmitters including entries of the appropriate range and tag number. Provide a printed record of smart device serial numbers against their assigned tag number.
- .3 Instruments to be set up and calibrated by an accredited instrument technician working under the approval of the instrument manufacturer.

INSTRUMENTATION AND CONTROL GENERAL REQUIREMENTS

- .4 Calibrate all instruments to an accuracy of half of 1 percent of full range, or to the manufacturer's stated accuracy of the instrument whenever an accuracy of half of 1 percent is not achievable.
- .5 Prior to instrument installation perform the following applicable calibration for each instrument and its associated signal conditioning equipment:
 - .1 Calibrate all inline flowmeters by a draw-down test.
 - .2 Calibrate all analytical instruments as specified by the manufacturer using manufacturer supplied calibration standards or lab samples as required.
 - .3 Calibrate all vacuum and pressure instruments by certified calibration standard.
 - .4 Calibrate gas detectors using standard gas samples.
 - .5 Calibrate temperature instruments against standard lab thermometers or by certified calibration standard.

3.14 Commissioning

- .1 Refer to the requirements of Division 1 for additional commissioning requirements.
- .2 Inspections
 - .1 Provide two weeks' written notice to the Contract Administrator prior to energizing any system to allow for inspection by the Contract Administrator of the following:
 - .1 Proper mounting.
 - .2 Proper connections.
 - .2 During Commissioning demonstrate to the Contract Administrator proper calibration and correct operation of instruments and gauges.
- .3 Commissioning of the instrumentation and control system to include but not be limited to the following.
 - .1 Supervise installation of components, wiring connections and piping connections.
 - .2 Supervise wiring continuity and pipe leak tests.
 - .3 Verify instrument calibration and provide written report.
 - .4 Function check and adjust under operational conditions the instruments and control equipment.
 - .5 Coordinate instruments and control equipment supplier's service personnel as required for complete system testing.
 - .6 Instruct plant personnel in correct method of operation of instruments and control equipment.

INSTRUMENTATION AND CONTROL GENERAL REQUIREMENTS

- .7 Direct plant personnel at hand-over as to final adjustment of the system for correct operation of plant.
- .8 Ensure that the instrumentation and control equipment suppliers cooperate to complete the Work of this Section.
- .9 Verify signal levels and wiring connections to all instrumentation and control equipment.
- .10 Coordinate and cooperate with City staff, equipment suppliers, and other contractors to commission Control system I/O points during equipment Commissioning.

3.15 Training

- .1 Provide training, described in detail in Division 1, as required by the plant's personnel to become fully competent in the proper operation and maintenance of all control devices, control valves, and ancillary instrumentation described under this Section of the Specification.

3.16 Test Forms

<u>Form No.</u>	<u>Title</u>
.1 ITR	Instrument Test Report
.2 LCR	Loop Check Report

INSTRUMENTATION AND CONTROL GENERAL REQUIREMENTS

LOOP CHECK REPORT

- CHECKED OUT OK
- NOT APPLICABLE
- FURTHER ACTION REQUIRED

	INSTRUMENT TAG NO.							
LOOP NO. _____ SHEET NO. _____ P & I DWG. NO. _____								
INSTALLATION COMPLETE								
Primary Element								
Impulse Lines								
Block and Drain Valves								
Air Supply/Filter/Reg.								
Wiring								
Tracing/Insulation/Housing								
Mounting and Location								
PLC/SCADA I/O & Status								
CALIBRATED								
Impulse Lines Press. Tested								
LOOP CHECKED								
Element To Receiver								
X Mtr. to Receiver								
X Mtr./Trans. to Receiver								
X Mtr./Trans. to Switches								
Switches to Annunciator								
Interlocking Circuit								
Controller to Valve								
Controller Action D or R								

REMARKS:

READY FOR START-UP

DATE: _____

Installed by: _____

Checked by: _____

INSTRUMENTATION AND CONTROL GENERAL REQUIREMENTS

INSTRUMENT TEST REPORT

SYSTEM: _____

SERVICE: _____ TAG NO. _____

LOCATION: _____

MAKE: _____ MODEL: _____

SERIAL NO.: _____ CSA: _____

ELEMENT: _____ RANGE: _____

DESIGN SETTING/RANGE: _____ CONTACT TO: _____ ON: _____

SIGNAL IN: _____ OUT: _____ ASSOCIATED INSTRUMENT: _____

INSTRUMENT CONDITION: _____ CONFORM TO SPEC: _____

PROJECT NO.: _____ DATA SHEET: _____

TEST METHOD	TEST 1				TEST 2			
	INPUT		OUTPUT		INPUT		OUTPUT	
PROCESS	INC.	DEC.	INC.	DEC.	INC.	DEC.	INC.	DEC.
TEST POINT 1								
TEST POINT 2								
TEST POINT 3								
TEST POINT 4								
TEST POINT 5								
COMMENTS								
GRAPHS								

TESTED BY: _____

CHECKED BY: _____

DATE: _____

DATE: _____

END OF SECTION

ENCLOSURES

1. GENERAL

1.1 References – General

- .1 Suppliers, Equipment, Products, and Execution must meet all requirements detailed in Section 17010.

2. PRODUCTS

2.1 General

- .1 Unless otherwise specified, provide outside finishes on all enclosures in ANSI 61 Grey.
- .2 The enclosures must be suitable for carrying the weight of the equipment mounted inside the panel and on the doors without any warpage.

2.2 Enclosures

- .1 Provide EEMAC Type 1A gasketed enclosures in MCC rooms and control rooms.
- .2 All enclosures for mounting outside of MCC rooms and control rooms to be EEMAC Type 4, watertight except where otherwise specified.
- .3 Provide EEMAC 7/3R enclosures for equipment in and around classified areas such as sumps.
- .4 Enclosures for certain equipment in corrosive atmospheres to be EEMAC 4X approved for the classification (e.g., chemical cleaning).
- .5 Enclosures for mounting field control indicator lamps and switches in unclassified areas to be Allen Bradley model 800T-xTZ die cast enclosures.
- .6 Enclosures for electrically hazardous classified areas to be rated for the specified hazard classification.
- .7 All enclosures and field accessories shall be weather proof if installed outdoors.

2.3 Panel Enclosures

- .1 Fabricate panel enclosures from 11 gauge steel panels complete with necessary stiffening to form a rigid free-standing lineup. The structures must be suitable for carrying the weight of the equipment mounted inside the panel and on the doors. Provide removable top and bottom cable entry plates.
- .2 Provide panels with front access only. Doors shall be key lockable and fitted with 3-point heavy duty latching assemblies. Provide a continuous piano hinge and a pneumatic hold open device on each door.
- .3 Finish the interior of the enclosure with white paint. Provide a switched fluorescent light fixture and 120 VAC duplex convenience receptacle inside the enclosure.

ENCLOSURES

2.4 Marshaling and Control Panels

- .1 Supply, fabricate, checkout, layout, document and deliver to Site fully equipped and functional panels.
- .2 Supply all components contained on or within the panels fully wired under this Section of the Specification.
- .3 The Selection of all accessories, materials and methods for fabrication not covered by this Specification, but which are necessary to complete the fabrication of the control panels, is the responsibility of the panel fabricator.
- .4 Marshaling and control panels shall be adequately sized to facilitate a professional, uncluttered arrangement. Provide adequate internal and external space to accommodate a 20 percent increase in each type of component used. Allow space for future installation of at least one (1) additional PLC or DCS rack as appropriate.

2.5 Wiring and Accessories

- .1 Provide wiring inside the panels according to the following Specifications:
 - .1 Control wiring to be a minimum of #16 AWG tinned stranded copper; insulation rated at 600 V.
 - .2 Wiring for power distribution shall be a minimum of #14 AWG tinned stranded copper; insulation rated at 600 V.
 - .3 Refer to Electrical Drawings for cable routing requirements.
- .2 Tag each wire at both ends with a heat shrink sleeve that is machine printed.
- .3 Wiring systems with different voltage levels or types shall be suitably segregated within the panel, according to relevant electrical codes.
- .4 Run all wiring in enclosed plastic wireways such as Panduit. Size all wireways so that the total cross sectional area of the insulated wire and cable does not exceed 40 percent of the cross sectional area of the wireway.
- .5 Provide a minimum clearance of 40 mm between wireways and any point of wire termination.
- .6 Terminate all wiring, incoming and outgoing, at terminal strips mounted inside the panels. Identify each terminal strip with a terminal strip number, defined as follows:
 - .1 Wire identification to use the connected field device tag name with the wire's corresponding terminal number appended to it.
 - .2 Identify every joint and/or terminal of the above wire run with the same identifier until the wire meets another tagged device, at which point the wire identifier will change to use the new device name and terminal number.
 - .3 For example, pressure transmitter K4-PT-100A located in the field has a 2CTPSH cable connected to it. The cable runs through a junction box to a marshaling panel. The wire

ENCLOSURES

identifiers for the pair of wires would be K4-PT-100A all the way to the marshaling panel.

- .4 Identify spare wires by using the destination identifier, i.e., the location and terminal identifier of the opposite end of the wire are combined to form the wire tag.
- .7 Provide a 120 VAC panel power distribution system and a 24 VDC power distribution system in each panel. Provide 12 VAC power for the CCTV fiber converters as required. Provide a thermal magnetic circuit breaker on each main power circuit and a fused terminal block for each branched circuit off the main.
- .8 Provide disconnect type terminal blocks Wieland WK4TSK/U type to isolate field wiring that is powered sourced from the panel.
- .9 Provide sufficient terminals so that not more than two (2) wires are connected under the same terminal. Provide 20 percent spare terminal capacity at each terminal block assembly.
- .10 Provide nameplates for each device on or within the panels and enclosures. Nameplates shall be black lamicaid with white lettering, a minimum of 25 mm x 75 mm in size with up to three lines of 3 mm lettering. Securely fasten nameplates in and situate them in a visible location.

2.6 Panel Grounding

- .1 Provide a ground system for the instrumentation circuits, isolated from the main power system ground to each marshaling panel.
- .2 Provide grounding lugs for each panel, suitable for termination of up to #2 AWG copper grounding conductor.
- .3 Provide in each marshaling panel an isolated grounding bus bar 6 x 25 x 600 mm, equipped with necessary lugs for accepting two (2) #2 AWG grounding conductors.
- .4 Firmly bond all panel-mounted devices on or within the panels to ground. Provide supplementary bonding conductors for backpanels and doors. Attach a separate bonding conductor to all devices that are not firmly fastened to the panels with screws for such devices as case mounted instruments, meters, etc.

3. EXECUTION

3.1 References – General

- .1 Refer to Section 17010, Part 3.

3.2 Mounting Heights

- .1 Unless otherwise specified or a conflict exists, mount all panels, starters and disconnects 2000 mm to top of cover.

END OF SECTION

INSTRUMENTATION CABLE

1. GENERAL

1.1 Product Data

- .1 Submit product data in accordance with Division 1 .

1.2 Related Work

- .1 Refer to Electrical Drawings.

1.3 Inspection

- .1 Provide adequate notice to the Contract Administrator so that all cable installations can be inspected prior to connecting equipment.

1.4 Standards

- .1 All wire and cable shall be CSA approved.

2. PRODUCTS

2.1 Twisted Pair Shielded Cables (TPSH)

- .1 TPSH shall be constructed as follows:
 - .1 Two (2) copper conductors, stranded, minimum #18 AWG, PVC insulated, twisted in nominal intervals of 50 mm.
 - .2 Insulated for 600 V, 90°C.
 - .3 100 percent coverage aluminum foil or tape shield.
 - .4 Separate bare stranded copper drain wire, minimum #18 AWG.
 - .5 Overall flame retardant PVC jacket to CSA-C22.2.
 - .6 The entire cable assembly to be suitable for pulling in conduit or laying in cable tray.
 - .7 Shaw Type 1751-CSA or Beldon equivalent.
- .2 Where multiconductor TPSH cables are called for, each pair shall be individually shielded, continuous number coded, and the cable assembly shall have an overall shield and overall flame retardant PVC jacket.

2.2 RTD and Multi Conductor Shielded Cable

- .1 RTD cables shall be CSA approved and shall be constructed as follows:
 - .1 Three (3) or more copper conductors, stranded, minimum #18 AWG.
 - .2 PVC insulated for 600 V.

INSTRUMENTATION CABLE

- .3 100 percent coverage aluminum foil or tape shield.
- .4 Separate bare stranded copper drain wire.
- .5 Overall flame retardant PVC jacket to CAS-C22.2.

2.3 Fiber Optic Cables

- .1 Provide fiber optic cable assemblies where indicated in the Specification and Drawings.
- .2 Fiber optic cables shall be constructed with specified quantity of 62.5/125 μm multi-mode glass fibers with individual and overall PVC jacket, spiral interlocked armour, and outer PVC jacket FT4 rated.
- .3 Provide terminations for fiber optic cables including; buffer tube fan out kits, connectors, termination panels, and wall mount enclosure.
- .4 Provide fiber optic jumpers 62.5/125 μm multi-mode for inter-cabinet connections.

3. EXECUTION

3.1 Analog Signals

- .1 Use TPSH cable for all low level analog signals such as 4-20 mA, 1-5 VDC, 0-10 VDC, pulse type circuits 24 VDC and under, and other signals of a similar nature.
- .2 Use RTD cable for connections between RTDs and transmitters or control system RTD inputs.

3.2 Digital Signals

- .1 Use TPSH cable for all low level input (24 V and below) and output signals to the control system.
- .2 Use Teck cable or wire and conduit for power to instruments, for 120 V signals other than those mentioned above and as otherwise indicated on the Drawings. Use stranded wire and cable to supply power to instruments.

3.3 Installation

- .1 Install instrumentation cables in conduit systems or in cable trays. Use a minimum of 300 mm length of liquid tight flexible conduit to connect the field sensors to the conduit.
- .2 Where non-armoured instrumentation cables are installed in cable trays, provide barriers in the tray to separate instrumentation cables from power cables.
- .3 At each end of the run leave sufficient cable length for termination.
- .4 Do not make splices in any of the instrumentation cable runs. Where splices are required, obtain approval from the Contract Administrator prior to installing the cable.

INSTRUMENTATION CABLE

- .5 Where splices are necessary in instrumentation cables other than coaxial cables, perform such splices on terminal blocks in terminal boxes. Keep splices in instrumentation cable to a minimum and separated physically from power circuits. Cable shields shall be terminated on insulated terminals and carried through to the extent of the cable.
- .6 Where splices are made to coaxial cables, use standard coaxial cable connectors.
- .7 Ground cable shields at one end only. Unless otherwise specified, ground the shields at the marshalling panel.
- .8 Protect all conductors against moisture during and after installation.

3.4 Conductor Terminations

- .1 All equipment supplied shall be equipped with terminal blocks to accept conductor connections.
- .2 Instrumentation conductors, where terminated at equipment terminals other than clamping type terminal blocks, shall be equipped with Burndy-YAE-2 or STA-KON, self-insulated, locking type terminators, sized as required to fit conductors and screw terminals.
- .3 Terminations of fiber optic cables shall be performed by factory trained technicians with appropriate tools and testing equipment.

3.5 Testing

- .1 Test all conductors for opens, shorts, or grounds. Resistance values shall not be less than those recommended by the cable manufacturer.
- .2 Test all fiber optic cables and terminations for signal integrity and manufacturer's specifications.

3.6 Identification

- .1 Identify all instrumentation cables.
- .2 Identify each conductor with wire numbers using a machine printed heat shrink wire marker, similar to Raychem TMS or equivalent in accordance with B7.

END OF SECTION

POWER SUPPLIES

1. GENERAL

1.1 References – General

- .1 Refer to Section 17010.

2. PRODUCTS

2.1 Power Supply and Conditioning Equipment

.1 General

- .1 Provide all DC power supplies as required for all instrument circuits. All circuits to be powered from the marshalling panels. Power supplies to be equal to Hammond or G.F.C., complete with an overvoltage protection module.
- .2 Provide redundant configurations for power supply equipment serving more than one (1) instrument loop, so that failure of a single unit will not disable all or any shared part of the instrumentation and communication system. Provide diode isolation for redundant direct current supply units, and ground the negative terminal of the power supply.
- .3 Power supplies and transmitters feeding circuits that run in non-armoured cable in cable tray shall meet the requirements for Class 2 circuits as defined under Section 16 of the CEC Part I.
- .4 Unless otherwise required, all DC power supplies to be rated 28 VDC, adjustable ± 5 percent, and set to provide 26.4 V on the panel direct current bus. Size the power supply for two (2) times the connected load, minimum size is 2 amps.

2.2 Noise Suppression

- .1 Provide power conditioners in each panel to power AC instrumentation and control loads. Power conditioners are Oneac Series CX.

2.3 UPS Power Supply

- .1 Provide an UPS for each marshalling panel to power the control system equipment and all I/O systems.
- .2 Provide a UPS for each computer workstation. Connect the workstation and its associated peripherals such as network concentrators, printers, etc., to the UPS.
- .3 Size UPS standby capacity for 30 minutes at full load rating.
- .4 Provide true on-line units from Exide, Oneac, Toshiba or Best.

POWER SUPPLIES

3. EXECUTION

3.1 References – General

- .1 Refer to Section 17010, Part 3.

END OF SECTION

SWITCHES AND RELAYS

1. GENERAL

1.1 References – General

- .1 Refer to Section 17010.

2. PRODUCTS

2.1 General

- .1 Use normally closed contacts for alarm actuation which open to initiate the alarm.
- .2 Use normally open contacts to control equipment. The contacts close to start the equipment.
- .3 Contacts monitored by solid state equipment to be hermetically sealed and adequately rated for the connected load.
- .4 Contacts monitored by electro-magnetic devices such as mechanical relays to be rated NEMA ICS 2, designation B300.
- .5 Provide double barriers between switch elements and process fluids such that failure of one (1) barrier will not permit process fluids into electrical enclosures.
- .6 Switch electrical enclosures to be rated EEMAC 4, minimum.

2.2 Indicators, Pushbuttons and Selector Switches

- .1 All control indicator lamps, pushbutton switches and selector switches in unclassified or non-corrosive areas to be Allen Bradley 800T or 800E series items.
- .2 All control indicator lamps, pushbutton switches and selector switches in classified or corrosive (includes outdoors) areas to be Allen Bradley 800H series items.
- .3 Enclosures to be as specified under Section 17110.

2.3 Relays

- .1 The Quality and type of relays shall be based on Omron types.
- .2 120 VAC relays to be Model LY 4PDT, plug-in, complete with test button and operation indicator, and surge suppressor.
- .3 24 VDC relays to be Model MY 2PDT plug-in, complete with test button and operation indicator, and surge suppressor diode.
- .4 Time delay relays for behind panel mounting to be Model H3BA, 2PDT, plug-in, and programmable for sixteen (16) time ranges and four (4) operation modes.
- .5 Time delay relays for flush panel mounting and operator accessible timing range modifications to be Model H5BR, SPDT, screw terminals, programmable for five (5) timing

SWITCHES AND RELAYS

ranges and eight (8) operation modes, complete with digital display, module for time settings and flexible protective cover.

- .6 Where the contact ratings of the relays listed are insufficient for the application select an appropriate type from an approved manufacturer with the same quantity of contacts as was originally specified.
- .7 Provide relay plug-in sockets for DIN mounting complete with stacked screw clamp terminals.

3. EXECUTION

3.1 References – General

- .1 Refer to Section 17010.

END OF SECTION

SIGNAL CONDITIONING MODULES

1. GENERAL

1.1 References – General

- .1 Refer to Section 17010.

2. PRODUCTS

2.1 Signal Conditioning Modules

- .1 Where required, provide signal conditioning modules which comply with the following requirements, unless otherwise specified:
 - .1 Analog signal inputs: 4-20 mA DC into 500 ohms.
 - .2 Analog signal outputs: 4-20 mA DC into 500 ohms.
 - .3 Discrete output contacts: SPDT rated 5A.
 - .4 Arrange electronic trips so that output contact opens in case of loss of signal or loss of power supply.
 - .5 Modules to be rated for continuous operation in an ambient temperature of 0 to 80°C. Ambient temperature effect not to exceed plus or minus 0.01 percent per degree Celsius within that range.
 - .6 Span and zero adjustments to be made by front accessible multi-turn potentiometers or keypad.
 - .7 Provide electronic trip modules with LED indicators for relay status.
 - .8 Modules to withstand 30 V per meter radio frequency radiation between 200 and 500 MHz with not more than 0.25 percent calibration effect. Provide modules with traps on the terminals to shunt conducted radio frequency interference to ground.
 - .9 Galvanically isolate signal and power supply terminals from the case.
- .2 All modules specified in this Section to be the product of a single manufacturer.

3. EXECUTION

3.1 References – General

- .1 Refer to Section 17010, Part 3.

END OF SECTION

PANEL INSTRUMENTS

1. GENERAL

1.1 References – General

- .1 Equipment, Products and Execution must meet all requirements detailed in Section 17010.

2. PRODUCTS

2.1 Electronic Panel Instruments

- .1 Provide panel instruments with the following requirements, unless otherwise specified:
 - .1 Analog instruments to be miniature-case drawout type nominally 150 mm high by 75 mm wide by not more than 350 mm deep.
 - .2 Make the operator, tuning and configuration adjustments accessible without disconnecting the instrument from the process.
 - .3 Analog signal indicators to be solid-state, LED or gas-discharge type, including bar-graph displays with not less than 200 segments. Backlit LCD indication is also acceptable.
 - .4 Analog signal inputs to be 4-20 mA VDC.
 - .5 Analog signal outputs to be 4-20 mA VDC into 500 ohms.
 - .6 Galvanically isolate the signal and power supply from the instrument case.
- .2 Panel instruments specified in this Section are to be the product of a single manufacturer, and to match and line up to form an integrated appearance and operator interface strategy.

3. EXECUTION

3.1 References – General

- .1 Refer to Section 17010.

END OF SECTION

MISCELLANEOUS PANEL DEVICES

1. GENERAL

1.1 References – General

- .1 Equipment, Products and Execution must meet all requirements detailed in Section 17010.

2. PRODUCTS

2.1 Miscellaneous Panel Devices

- .1 Pilot Lights:
 - .1 Provide pilot lights of the LED transformer type for extended lamp life, oil tight, push to test, complete with appropriate colour lenses. Normal colours used are run=red, stop=green unless otherwise depicted elsewhere.
 - .2 Terminals:
 - .1 Provide strap screw type terminal blocks rated for 600 V.
 - .2 Identify each terminal block within an enclosure with a unique machine printed terminal block number. Cabinet chassis grounding terminal blocks to be identified by the electrical ground symbol.
 - .3 Connections to screw terminals to be locking fork tongue insulated crimp type wire connectors.
 - .4 Terminals to be Wieland or approved equal.
 - .5 Provide a group of terminals for each of 120 VAC hot and neutral and 24 VDC positive and negative power. Distribution wiring to have a thermal magnetic circuit breaker upstream of all major blocks of loads, adequately sized to protect the connected load while not causing nuisance tripping.
 - .6 Provide Wieland disconnect type terminal blocks for each load or loop powered from the marshalling panels.
 - .3 Nameplates:
 - .1 Refer to Section 17010 for nameplate Specification.

2.2 Signal Current Isolator

- .1 Isolator to provide galvanic isolation of milliampere transmission signals from transmitters with inadequately isolated output circuits.
- .2 Isolator to be housed in a National Electrical Manufacturers Association (NEMA) 250, Type 4/7 conduit body and derive its operating power from the signal input circuit.
- .3 Input and output signals to be 4 to 20 mA, with an error not exceeding 0.1 percent of span. Input resistance will not exceed 550 ohms with an output load of 250 ohms.

MISCELLANEOUS PANEL DEVICES

- .4 Isolator to be Moore Industries.

2.3 Intrinsic Safety Barriers and Relays

- .1 Provide intrinsic safety barriers where required for two-wire transmitters of the active, isolating, loop powered type; MTL Type MT3042, Stahl 9005/01-252/100/00, P+F ZG series, or equivalent in accordance with B7.
- .2 Provide dual type intrinsic safety barriers for process switches; MTL 787, Panalarm 201-BR2.
- .3 Intrinsic safety relays to be Gems, or Warrick.

2.4 Industrial Ethernet Switches

- .1 Switches shall comply with IEEE 802.3, 802.3u, 802.3x, 802.1D.
- .2 Switches shall include a minimum of six 10/100 Base T(x) RJ45 Ports and two multimode 100 Base FX Fiber ports.
- .3 Switches shall include one (1) relay output alarm contact rated for 1A at 24 VDC.
- .4 Input power shall be capable of ranging from 9 to 32 VDC with redundant inputs.
- .5 Switches shall be fast spanning for a sub-second recovery in a ring configuration.
- .6 Switches shall be Moxa Technology ED6008 Series or approved equal.

2.5 NTSC Fiber Transmitters/Receivers

- .1 Models shall have a minimum of four (4) NTSC compliant channels and one (1) multimode fiber channel.
- .2 Transmitters and receivers shall be supplied with a regulated switching power supply with a 120 VAC input.
- .3 Transmitters and receivers shall be Pelco FT8304MSTR and FR8304MSTR respectively.

3. EXECUTION

3.1 References – General

- .1 Refer to Section 17010, Part 3.

END OF SECTION

CONTROL AND OPERATOR INTERFACE REQUIREMENTS

1. GENERAL

1.1 General Requirements

- .1 Connection of new input and output wiring terminations to an existing ABB Harmony based control system for the Nitrogen Removal facility that will control and monitor the system in accordance with the requirements defined by the Contract Documents.
- .2 The ABB Harmony system is currently housed in a central free standing multiple cabinet assembly located in the nitrogen removal building control room.
- .3 Cooperate with the process equipment vendors, other contractors, and City staff to interface and test the new DCS inputs and outputs.
- .4 Start-up and Commission the control system and associated field devices and wiring.

2. PRODUCTS

2.1 ABB Harmony System

- .1 General
 - .1 All new control system equipment (if required) to be based on the ABB Harmony family as applicable (no substitutions allowed).
 - .2 Control system logic configuration shall be done on the existing Plant DCS system by City personnel.

2.2 System Integration Requirements

- .1 Cooperate and coordinate activities with other contractors, City of Winnipeg (City) staff, and consultants to facilitate installation, testing, validation, and commissioning of the upgraded Nitrogen Removal Facility.
- .2 Supply, install, test and commission the central control system equipment as specified in this Division and as shown on the Drawings.
- .3 All equipment testing and commissioning responsibilities must be carried out while at the same time maintaining availability of the main Plant DCS. Any equipment outage requirements are to be kept to a minimum and are to be scheduled with the Contract Administrator prior to implementation.

3. EXECUTION

3.1 Performance – General

- .1 Refer to Section 17010, Part 3.

3.2 Installation

- .1 Provide hardware in accordance with the foregoing requirements in sufficient quantity to satisfy the performance requirements defined in this and other Divisions of the Specification.

CONTROL AND OPERATOR INTERFACE REQUIREMENTS

- .2 Provide all necessary documentation to define the control system including details for all hardware.
- .3 Commission and start up the system as defined herein.
- .4 Provide all documentation and training as defined herein.
- .5 Maintain existing plant operation during entire Construction Period. Refer to the requirements of Division 1.

END OF SECTION

DCS INPUT/OUTPUT INDEX

1. GENERAL

1.1 References – General

.1 Refer to Section 17010.

1.2 PLC I/O Index

.1 The following spreadsheet gives an itemized list of the I/O between the DCS and the field devices. It is intended to serve as an aid for determining the cabling requirements for the Work specified in this Division.

.2 Refer to Division 17 Section 17500 for required I/O spare requirements for each type of I/O.

.3 All control circuits and I/O points shall be individually fused.

2. PRODUCTS (NOT USED)

3. EXECUTION (NOT USED)

DISTRIBUTED CONTROL SYSTEM INPUT/OUTPUT LIST

NO.	REV. NO.	TAG NAME					DESCRIPTION		P&ID DRAWING	I/O SPECIFICATION					
		PCU		DEVICE			FUNCTION	SERVICE		ENG. UNITS	SCALE / SP LOW-HIGH	ALARMS		I/O POINT TYPE	I/O POINT NO.
		AREA	PNL	TAG								LO / 0	HI / 1		
1	0	C	A	C185	AT	11	Dissolved Oxygen Reading	SBR 1 Aeration Zone 1	P6.01	mg/l	0 - 8	tba	tba	AI	1-5B-AI4
2	0	C	A	C185	AT	12	PH Reading	SBR 1 Aeration Zone 1	P6.01	PH	4 - 10	tba	tba	AI	1-5B-AI5
3	0	C	A	C185	AF	1	DO/PH Analyzer Fault	SBR 1 Aeration Zone 1	P6.01	n/a	0 = Fault	Alarm	Normal	DI	4-3B-DI3
4	0	C	A	C185	AT	21	Dissolved Oxygen Reading	SBR 1 Aeration Zone 2	P6.01	mg/l	0 - 10	tba	tba	AI	1-5B-AI6
5	0	C	A	C185	AT	22	PH Reading	SBR 1 Aeration Zone 2	P6.01	PH	4 - 11	tba	tba	AI	1-5B-AI7
6	0	C	A	C185	AF	2	DO/PH Analyzer Fault	SBR 1 Aeration Zone 2	P6.01	n/a	0 = Fault	Alarm	Normal	DI	4-3B-DI4
7	0	C	A	C185	AT	31	Dissolved Oxygen Reading	SBR 1 Aeration Zone 3	P6.01	mg/l	0 - 10	tba	tba	AI	1-5B-AI8
8	0	C	A	C185	AT	32	PH Reading	SBR 1 Aeration Zone 3	P6.01	PH	4 - 11	tba	tba	AI	1-5B-AI9
9	0	C	A	C185	AF	3	DO/PH Analyzer Fault	SBR 1 Aeration Zone 3	P6.01	n/a	0 = Fault	Alarm	Normal	DI	4-3B-DI9
10	0	C	A	C185	AT	41	Ammonia (NH ₃) Reading	SBR 1 Decanter Zone	P6.01	mg/l	0 - 100	tba	tba	AI	1-5B-AI10
11	0	C	A	C185	AT	42	Nitrite (NO ₂) Reading	SBR 1 Decanter Zone	P6.01	mg/l	0 - 750	tba	tba	AI	1-5B-AI11
12	0	C	A	C185	AF	4	NH ₃ /NO ₂ Analyzer Fault	SBR 1 Decanter Zone	P6.01	n/a	0 = Fault	Alarm	Normal	DI	4-3B-DI0
13	0	C	A	C285	AT	11	Dissolved Oxygen Reading	SBR 2 Aeration Zone 1	P6.02	mg/l	0 - 10	tba	tba	AI	1-5B-AI12
14	0	C	A	C285	AT	12	PH Reading	SBR 2 Aeration Zone 1	P6.02	PH	4 - 11	tba	tba	AI	1-5B-AI15
15	0	C	A	C285	AF	1	DO/PH Analyzer Fault	SBR 2 Aeration Zone 1	P6.02	n/a	0 = Fault	Alarm	Normal	DI	4-3B-DI13
16	0	C	A	C285	AT	21	Dissolved Oxygen Reading	SBR 2 Aeration Zone 2	P6.02	mg/l	0 - 10	tba	tba	AI	1-6A-AI2
17	0	C	A	C285	AT	22	PH Reading	SBR 2 Aeration Zone 2	P6.02	PH	4 - 11	tba	tba	AI	1-6A-AI3
18	0	C	A	C285	AF	2	DO/PH Analyzer Fault	SBR 2 Aeration Zone 2	P6.02	n/a	0 = Fault	Alarm	Normal	DI	4-3B-DI14
19	0	C	A	C285	AT	31	Dissolved Oxygen Reading	SBR 2 Aeration Zone 3	P6.02	mg/l	0 - 10	tba	tba	AI	1-6A-AI4
20	0	C	A	C285	AT	32	PH Reading	SBR 2 Aeration Zone 3	P6.02	PH	4 - 11	tba	tba	AI	1-6A-AI5
21	0	C	A	C285	AF	3	DO/PH Analyzer Fault	SBR 2 Aeration Zone 3	P6.02	n/a	0 = Fault	Alarm	Normal	DI	4-3B-DI15
22	0	C	A	C285	AT	41	Ammonia (NH ₃) Reading	SBR 2 Decanter Zone	P6.02	mg/l	0 - 100	tba	tba	AI	1-6A-AI6
23	0	C	A	C285	AT	42	Nitrite (NO ₂) Reading	SBR 2 Decanter Zone	P6.02	mg/l	0 - 750	tba	tba	AI	1-6A-AI7
24	0	C	A	C285	AF	4	NH ₃ /NO ₂ Analyzer Fault	SBR 2 Decanter Zone	P6.02	n/a	0 = Fault	Alarm	Normal	DI	4-3B-DI16
25	0	C	A	C626	XN		Enable/Disable Command	Soda Ash Silo Air Cannon System	P10.02	n/a	1 = Enable	n/a	n/a	DO	4-2C-DO5
26	0	C	A	C627	MM		Run Indication	Soda Ash Silo Dehumidifier	P10.02	n/a	1 = Run	n/a	n/a	DI	4-4B-DI9
27	0	C	A	C627	UA		Fault	Soda Ash Silo Dehumidifier	P10.02	n/a	0 = Fault	Alarm	Normal	DI	4-4B-DI10
28	0	C	A	C645	AT	1	Conductivity Reading	Soda Ash Solution Tank C645	P10.03	mho/cm	0 - 0.15	tba	tba	AI	1-6A-AI8
29	0	C	A	C645	AF	1	Conductivity Analyzer Fault	Soda Ash Solution Tank C645	P10.03	n/a	0 = Fault	Alarm	Normal	DI	4-4B-DI11
30	0	C	A	C661	YS		Computer Selected	Lime Metering Pump	P10.03	n/a	1 = Computer	n/a	n/a	DI	4-4B-DI12
31	0	C	A	C661	MN		Start/Stop Command	Lime Metering Pump	P10.03	n/a	1 = Run	n/a	n/a	DO	4-2C-DO10
32	0	C	A	C661	UA		Fault	Lime Metering Pump	P10.03	n/a	0 = Fault	Alarm	Normal	DI	4-4B-DI13

INSTRUMENT INDEX

1. GENERAL

1.1 References – General

.1 Refer to Section 17010.

1.2 Instrument Index

.1 The following spreadsheet gives an itemized list of the instrumentation included as part of this Work.

.2 All equipment supplied under this division and by other divisions shall be installed under Division 17.

2. PRODUCTS

.1 Not used.

3. EXECUTION

.1 Not used.

END OF SECTION

INSTRUMENT INDEX

RECORD NO.	REV. NO.	TAG NAME				DESCRIPTION		REFERENCES				
						INSTRUMENT TYPE	SERVICE	SPEC. SHEET or SECTION	P&ID DRAWING	WIRING REF.	LOCATION DWG	SUPPLY CODE
1	0	C	185 285	AT	1	2 Channel Analytical Transmitter	SBR 1 or 2 Aeration Zone 1	Existing	P6.01	ILD-001	E-0001	City
2	0	C	185 285	AE	11	PH Probe	SBR 1 or 2 Aeration Zone 1	Existing	P6.01	ILD-001	E-0001	City
3	0	C	185 285	AE	12	Dissolved Oxygen Probe	SBR 1 or 2 Aeration Zone 1	Existing	P6.01	ILD-001	E-0001	City
4	0	C	185 285	AT	2	2 Channel Analytical Transmitter	SBR 1 or 2 Aeration Zone 2	Existing	P6.01	ILD-001	E-0001	City
5	0	C	185 285	AE	21	PH Probe	SBR 1 or 2 Aeration Zone 2	Existing	P6.01	ILD-001	E-0001	City
6	0	C	185 285	AE	22	Dissolved Oxygen Probe	SBR 1 or 2 Aeration Zone 2	Existing	P6.01	ILD-001	E-0001	City
7	0	C	185 285	AT	3	2 Channel Analytical Transmitter	SBR 1 or 2 Aeration Zone 3	17701	P6.01	ILD-001	E-0001	CON
8	0	C	185 285	AE	31	PH Probe	SBR 1 or 2 Aeration Zone 3	17701	P6.01	ILD-001	E-0001	CON
9	0	C	185 285	AE	32	Dissolved Oxygen Probe	SBR 1 or 2 Aeration Zone 3	17701	P6.01	ILD-001	E-0001	CON
10	0	C	185 285	AT	4	2 Channel Analytical Transmitter	SBR 1 or 2 Decant Zone	17701	P6.01	ILD-001	E-0001	CON
11	0	C	185 285	AE	41	Nitrite Probe (NO ₂)	SBR 1 or 2 Decant Zone	17701	P6.01	ILD-001	E-0001	CON
12	0	C	185 285	AE	42	Ammonia Probe (NH ₃)	SBR 1 or 2 Decant Zone	17701	P6.01	ILD-001	E-0001	CON
13	0	C	626	LCP		Silo Air Cannon System	Soda Ash Silo	11800	P10.02	ILD-004	P18.02	CON
14	0	C	627	AD		Silo Dehumidifier system	Soda Ash Silo	11800	P10.02	ILD-003	P18.02	CON
15	0	C	645	AT	1	2 Channel Analytical Transmitter	Soda Ash Solution Tank C645	17701	P10.03	ILD-001	P18.02	CON
16	0	C	645	AE	11	Conductivity Probe	Soda Ash Solution Tank C645	17701	P10.03	ILD-001	P18.02	CON
17	0	C	661	P		Metering Pump	Soda Ash Makedown Lime Clear System	11363	P10.03	ILD-002	P18.02	CON

INSTRUMENT SPECIFICATION SHEETS

1. GENERAL

1.1 References - General

- .1 Refer To Section 17010.

1.2 Instrument Specification Sheets

- .1 The following data sheets provide information for instruments included as part of this Work.

I-101	Instrument Specification Sheet – DO & PH Measuring System
I-102	Instrument Specification Sheet – Conductivity Measuring System
I-103	Instrument Specification Sheet – NO ₂ & NH ₃ Measuring System

- .2 All instruments described on each instrument Specification sheet are to be from a single source. Design has been based on the first named Product.

2. PRODUCTS (NOT USED)

3. EXECUTION (NOT USED)

INSTRUMENT SPECIFICATION SHEETS

INSTRUMENT SPECIFICATION NUMBER:	I101
DEVICE:	Dissolved Oxygen and PH Measuring System
TAGS:	Refer to Instrument Index
PROBE TYPE:	Submersible optical DO probe Submersible glass electrode PH probe
OPERATING PRINCIPLE:	DO: Fluorescence Quenching digital probe PH: Ion Selective Glass Electrode digital probe
PROBE HOLDER LENGTH:	Overall probe holder length will be approximately 5 m. To be confirmed on site.
SERVICE:	SBR Tanks Centrate. Refer to Process for characteristics
SELF CLEANING/CALIBRATION:	Air blast cleaning
TEMPERATURE COMPENSATION:	Integral
CABLE LENGTH:	10 m pre-terminated cables complete with quick connectors for each sensor.
RANGE:	DO: 0-10 mg/L PH: 4-11 PH units
INACCURACY:	±0.5% of span or better
TRANSMITTER TYPE:	2 Channel digital transmitter suitable for connection of digital process sensors.
OUTPUT:	Isolated 4 to 20 mA analog output(s) for each channel. 2 configurable Form C alarm contacts N/O
COMMUNICATIONS:	Profibus PA preferred, Profibus DP alternate
POWER SUPPLY:	120 VAC, 60 HZ
ENCLOSURE:	EEMAC/NEMA 4X transmitter housing
MOUNTING:	(SENSORS) NPT thread for 2" vertical pipe mount. Refer to drawing E-0001 for probe mounting details. (TRANSMITTER) Wall mount
ACCESSORIES:	Sensor air blast cleaning heads for each sensor probe. 10 m air blast supply tubing for each sensor probe. Solenoid valves for air blast control of each sensor probe. Calibration kit.
MANUFACTURER AND MODEL:	E&H Hach ATi or approved equal

INSTRUMENT SPECIFICATION SHEETS

INSTRUMENT SPECIFICATION NUMBER:	I102
DEVICE:	Conductivity Measuring System
TAGS:	Refer to Instrument Index
PROBE TYPE:	Submersible Toroidal Conductivity Probe
OPERATING PRINCIPLE:	Inductance type digital conductivity probe
PROBE HOLDER LENGTH:	Overall probe holder length will be approximately 1 m. To be confirmed on site.
SERVICE:	Soda Ash Slurry Batching Tank
TEMPERATURE COMPENSATION:	Integral
CABLE LENGTH:	5 m complete with quick connectors for the sensor.
RANGE:	2uS/cm to 2000mS/cm
INACCURACY:	±0.2% of reading or better
TRANSMITTER TYPE:	2 Channel digital transmitter suitable for connection of digital process sensors.
OUTPUT:	Isolated 4 to 20 mA Analog Output(s) for each channel. 2 configurable Form C alarm contacts N/O
COMMUNICATIONS:	Profibus PA preferred, Profibus DP alternate
POWER SUPPLY:	120 VAC, 60 HZ
ENCLOSURE:	EEMAC/NEMA 4X transmitter housing
MOUNTING:	(SENSORS) NPT thread for 2" pipe mount. (TRANSMITTER) Wall mount
ACCESSORIES:	Calibration kit.
MANUFACTURER AND MODEL:	E&H Hach ATi or approved equal

INSTRUMENT SPECIFICATION SHEETS

INSTRUMENT SPECIFICATION NUMBER:	I103
DEVICE:	Nitrite (NO ₂) and Ammonia (NH ₃) Measuring System
TAGS:	Refer to Instrument Index
PROBE TYPE:	Submersible Nitrite - NO ₂ Probe Submersible Ammonia - NH ₃ Probe
OPERATING PRINCIPLE:	NO ₂ : UV light absorbance digital probe NH ₃ : Ion Selective Electrodes digital probe
PROBE HOLDER LENGTH:	Overall probe holder length will be approximately 5 m. To be confirmed on site.
SERVICE:	SBR Tanks Centrate, Refer to process for characteristics.
TEMPERATURE COMPENSATION:	Integral
CABLE LENGTH:	10 m pre-terminated cables complete with quick connectors for each sensor.
RANGE:	NO ₂ : 0.0 to 100 mg/l NH ₃ : 0.0 to 750 mg/l
INACCURACY:	±2.5% of span or better for NO ₂ probe ±3.0% of span or better for NH ₃ probe
TRANSMITTER TYPE:	Multi - Channel digital transmitter suitable for connection of digital process sensors.
OUTPUT:	Isolated 4 to 20 mA analog output(s) for each channel. 2 configurable Form C alarm contacts N/O
COMMUNICATIONS:	Profibus PA preferred, Profibus DP alternate
POWER SUPPLY:	120 VAC, 60 HZ
ENCLOSURE:	EEMAC/NEMA 4X transmitter housing Submersible sensor probes
MOUNTING:	(SENSORS) Mounting adaptor for vertical 2" pipe mount. Refer to drawing E-0001 for probe mounting details. (TRANSMITTER) Wall mount
ACCESSORIES:	Sensor air blast cleaning fittings, tubing (2x10 m), and solenoids for use with customer supplied air source.
MANUFACTURER AND MODEL:	S::CAN <ul style="list-style-type: none">• Spectro::lyser NO₂ probe c/w calibration• Ammo::lyser NH₃ probe c/w calibration• Con::Cube multi - channel digital transmitter• Accessories as noted above or approved equal

END OF SECTION

INSTRUMENT LOOP DRAWINGS

1. GENERAL

1.1 References - General

- .1 Refer to Section 17010.

1.2 Instrument Loop Drawings

- .1 The following Drawings show typical instrument loop wiring diagrams. One (1) Drawing per loop will be completed and submitted for approval after award of Contract. The following drawings are an integral part of this Specification Section:

ILD-01	Typical Analytical Transmitter
ILD-02	Typical Chemical Metering Pump
ILD-03	Typical Dehumidifier
ILD-04	Typical Silo Air Cannon

- .2 All control circuits and I/O points shown on the instrument loop wiring diagrams shall be individually fused.
- .3 The instrument loop wiring diagrams are intended to be typical. For instruments being supplied by Vendor Packages or under other Divisions refer to detailed wiring schematics and documentation provided by the supplier.

2. PRODUCTS (NOT USED)

3. EXECUTION (NOT USED)

Analytical Transmitter - Instrument Loop Diagram

Loop No. 001

FIELD PROCESS AREA

CONTROL PANEL

DCS

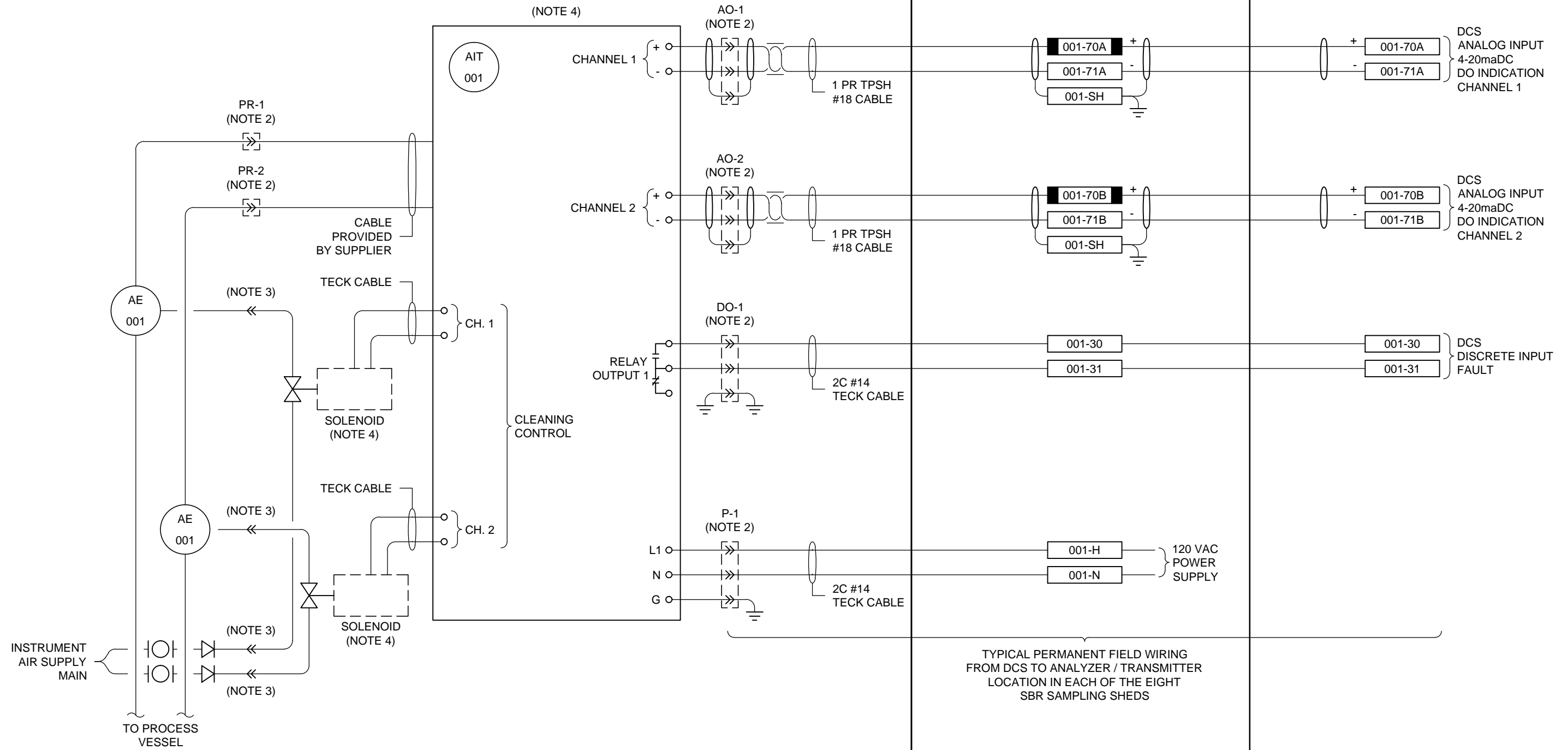

NOTES:

1. THIS DRAWING IS TYPICAL FOR ONE OR MORE APPLICATIONS, REFER TO INSTRUMENT INDEX.
2. USE AMPHENOL ROUND STYLE MULTI-PIN QUICK CONNECTORS WITH NEMA 4X RATING & OPTIONAL THREADED DUST CAPS. CONNECTOR FITMENTS FOR PROBES, ANALOG I/O, DISCRETE I/O & POWER SHALL ALL BE UNIQUE. PROVIDE UNIQUE TAGGING AT ALL CONNECTIONS.
3. USE BARBED FITTINGS WITH STAINLESS STEEL LCLAMPS FOR ALL PNEUMATIC CONNECTIONS. PROVIDE UNIQUE TAGGING AT ALL CONNECTIONS.
4. MOUNT ANALYZER / TRANSMITTER AND SOLENOID VALVES TO A COMMON BACKBOARD TO FACILITATE RAPID RELOCATION.

ISSUE/REVISION

I/R	DATE	DESCRIPTION
1	16/04/05	ISSUED FOR TENDER: BID OP 145-2016

CONSULTANT

AECOM Canada, Ltd.
 99 Commerce Drive
 Winnipeg, Manitoba R3P 0Y7
 204.477.5381 tel 204.284.2040 fax
 www.aecom.com



PROJECT

2016 NEWPCC
 SBR UPGRADES

2230 MAIN ST.
 WINNIPEG, MB
 R2V 4T8

SHEET TITLE

TYPICAL ANALYTICAL TRANSMITTER
 INSTRUMENT LOOP DIAGRAM

SHEET NUMBER

ILD-001

Small Metering Pump - Instrument Loop Diagram

Loop No. 002

ELECTRICAL ROOM

CONTROL PANEL

DCS

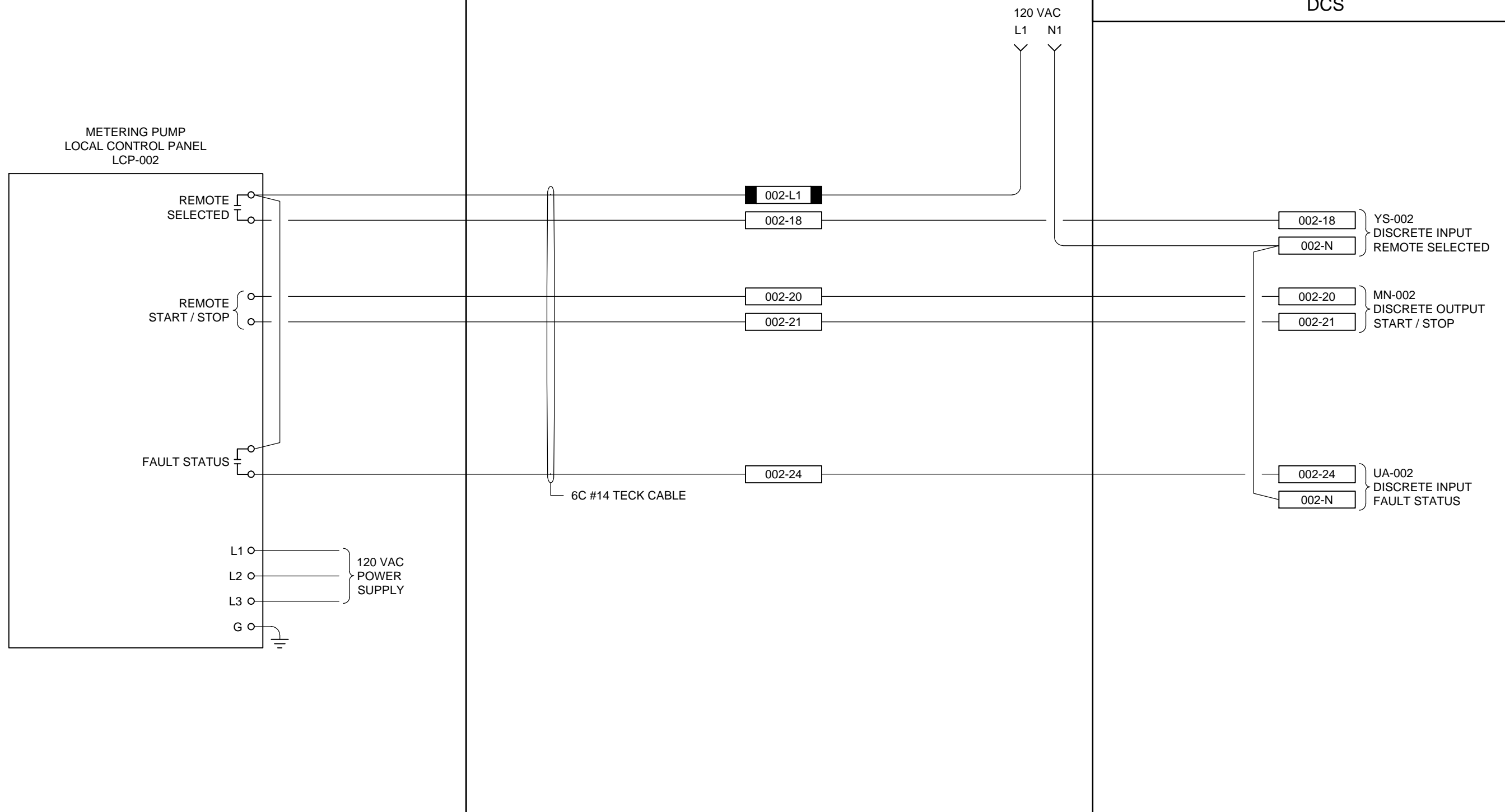

NOTES:

1. THIS DRAWING IS TYPICAL FOR ONE OR MORE APPLICATIONS, REFER TO INSTRUMENT INDEX.
2. REFER TO SHOP DRAWING FOR POWER REQUIREMENTS.

ISSUE/REVISION

I/R	DATE	DESCRIPTION
1	16/04/05	ISSUED FOR TENDER: BID OP 145-2016

CONSULTANT

AECOM Canada, Ltd.
 99 Commerce Drive
 Winnipeg, Manitoba R3P 0Y7
 204.477.5381 tel 204.284.2040 fax
 www.aecom.com



PROJECT

**2016 NEWPCC
 SBR UPGRADES**

2230 MAIN ST.
 WINNIPEG, MB
 R2V 4T8

SHEET TITLE

TYPICAL SMALL METERING PUMP
 INSTRUMENT LOOP DIAGRAM

SHEET NUMBER

ILD-002

Project Management Initials: DES: AAA CHK: BEB APP: CCC
 Last saved by: GALBICHKAS(2016-04-05) Last Plotted: 2016-04-05
 Filename: P:\60338393\900-WORK\910-CAD\20-SHEETS\ILD-001.DWG

Dehumidifier - Instrument Loop Diagram

Loop No. 003

ELECTRICAL ROOM

CONTROL PANEL

DCS

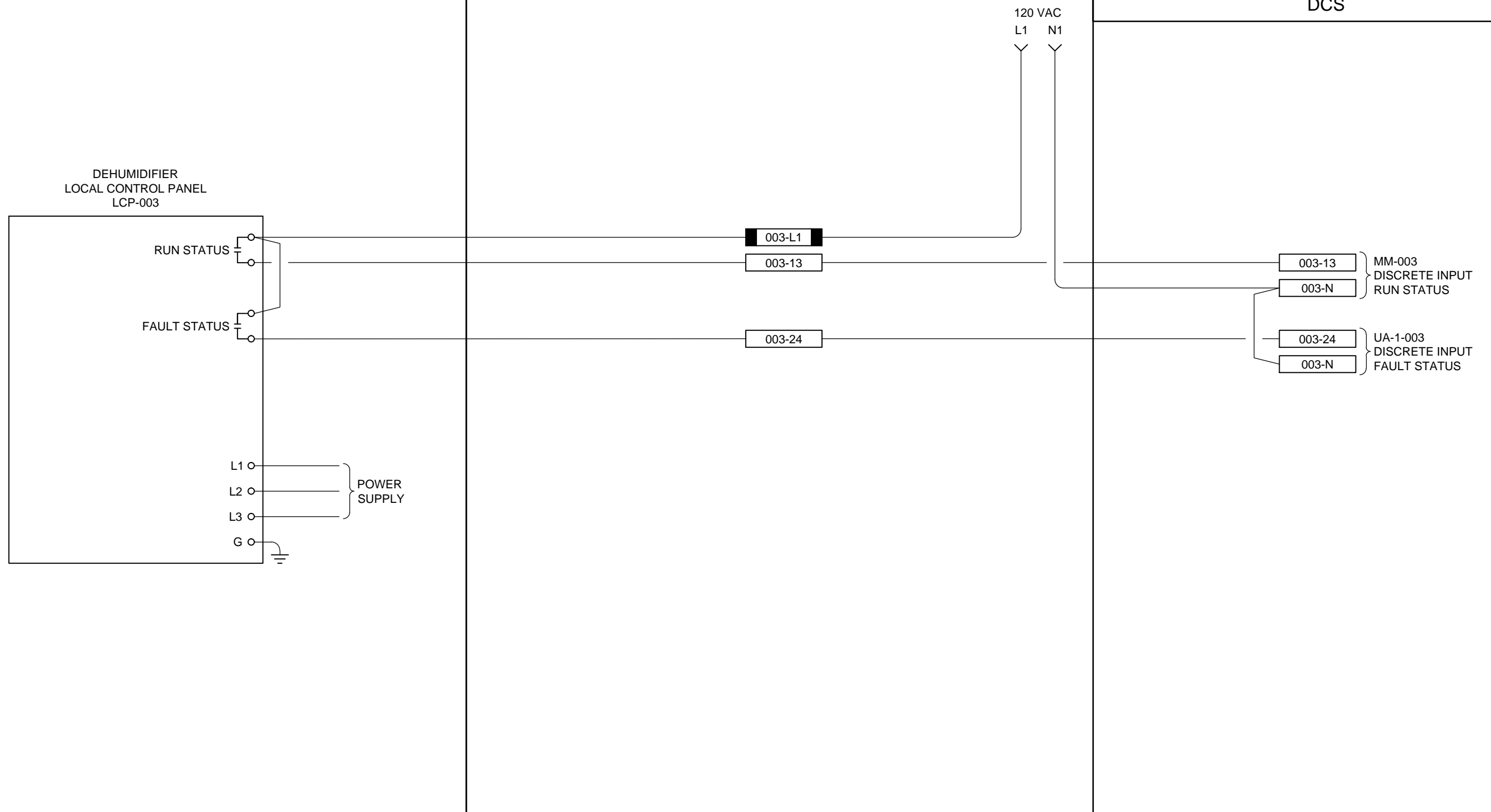

Project Management Initials: DES: AAA CHK: BEB APP: CCC
 Last saved by: GALBICHKAS(2016-04-05) Last Plotted: 2016-04-05
 Filename: P:\60338393\900-WORK\910-CAD\20-SHEETS\ILD-001.DWG

NOTES:

- THIS DRAWING IS TYPICAL FOR ONE OR MORE APPLICATIONS, REFER TO INSTRUMENT INDEX.

ISSUE/REVISION

I/R	DATE	DESCRIPTION
1	16/04/05	ISSUED FOR TENDER: BID OP 145-2016

CONSULTANT

AECOM Canada, Ltd.
 99 Commerce Drive
 Winnipeg, Manitoba R3P 0Y7
 204.477.5381 tel 204.284.2040 fax
 www.aecom.com



PROJECT

**2016 NEWPCC
 SBR UPGRADES**

2230 MAIN ST.
 WINNIPEG, MB
 R2V 4T8

SHEET TITLE

TYPICAL DEHUMIDIFIER
 INSTRUMENT LOOP DIAGRAM

SHEET NUMBER

ILD-003

Silo Air Cannon - Instrument Loop Diagram

Loop No. 004

ELECTRICAL ROOM

CONTROL PANEL

PLC

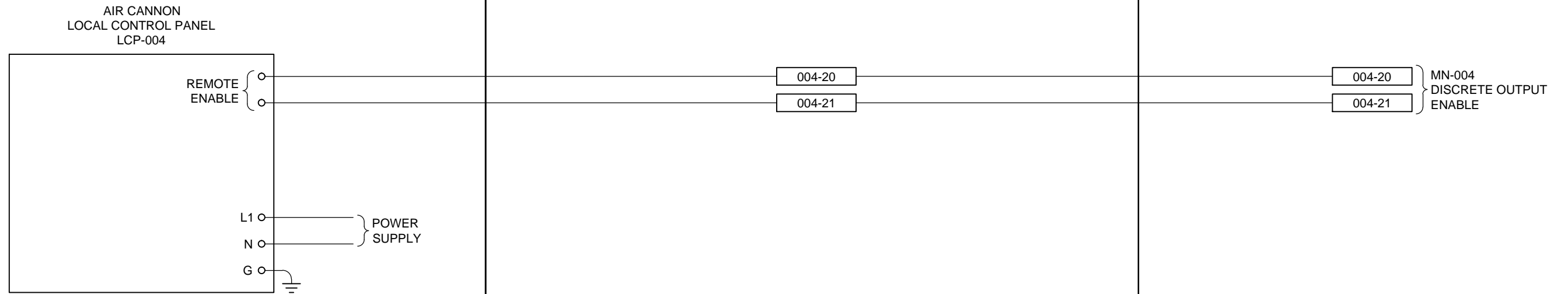

NOTES:

- THIS DRAWING IS TYPICAL FOR ONE OR MORE APPLICATIONS, REFER TO INSTRUMENT INDEX.

ISSUE/REVISION

I/R	DATE	DESCRIPTION
1	16/04/05	ISSUED FOR TENDER: BID OP 145-2016

CONSULTANT

AECOM Canada, Ltd.
99 Commerce Drive
Winnipeg, Manitoba R3P 0Y7
204.477.5381 tel 204.284.2040 fax
www.aecom.com



PROJECT

**2016 NEWPCC
SBR UPGRADES**

2230 MAIN ST.
WINNIPEG, MB
R2V 4T8

SHEET TITLE

TYPICAL SILO AIR CANNON
INSTRUMENT LOOP DIAGRAM

SHEET NUMBER

ILD-004

Project Management Initials: DES: AAA CHK: BEB APP: CCC

Last saved by: GALBICHKAS(2016-04-05) Last Plotted: 2016-04-05
Filename: P:\60338393\900-WORK\910-CAD\20-SHEETS\ILD-001.DWG