

# **APPENDIX 'C'**

## **CONSTRUCTION DETAIL**

### **SCD-106**

**PRODUCT #:**

**SILVER POWDERCOATED -**  
(Metal suitably cleaned to remove any grease, wax etc. for proper paint bonding to occur. Base coat Zinc rich primer. Baked with a final thickness of paint between 5-8 mil - # 52501051

**Galvanized Finish: #**  
**52501051GLV**

Drawing Title:

**WASTE RECEPTACLE  
EXPANDED METAL BASKET**

Drawing No:

**SCD-106**

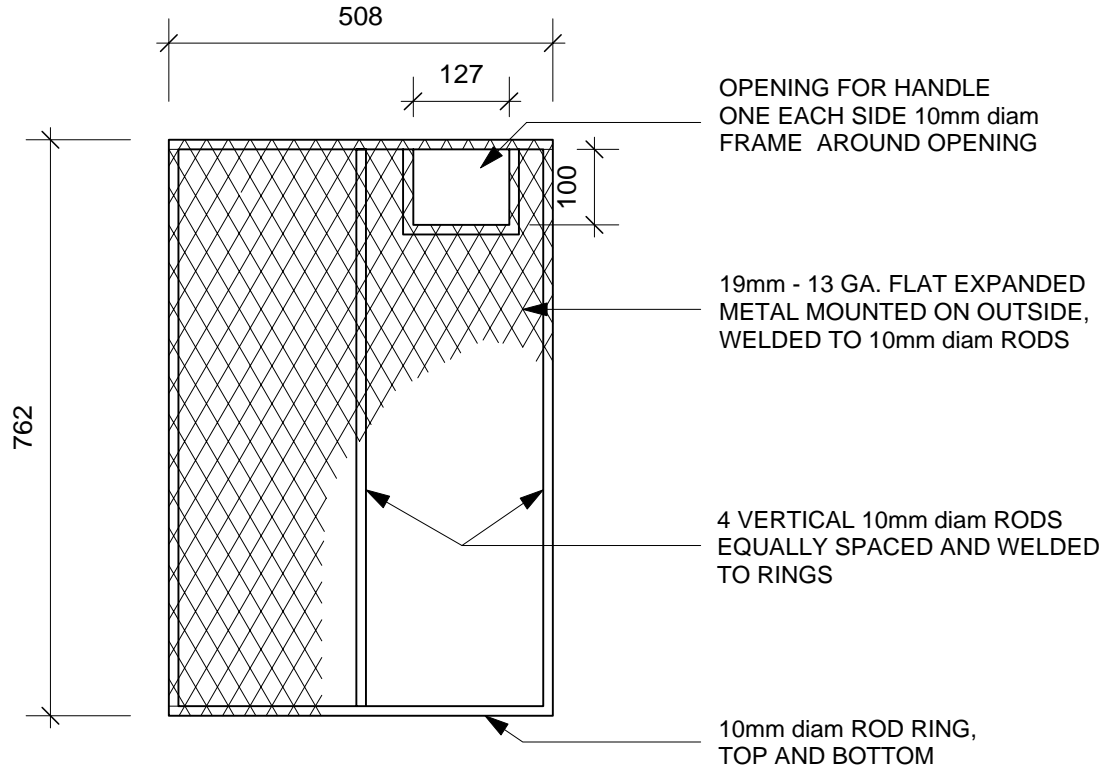

**SIDE VIEW**

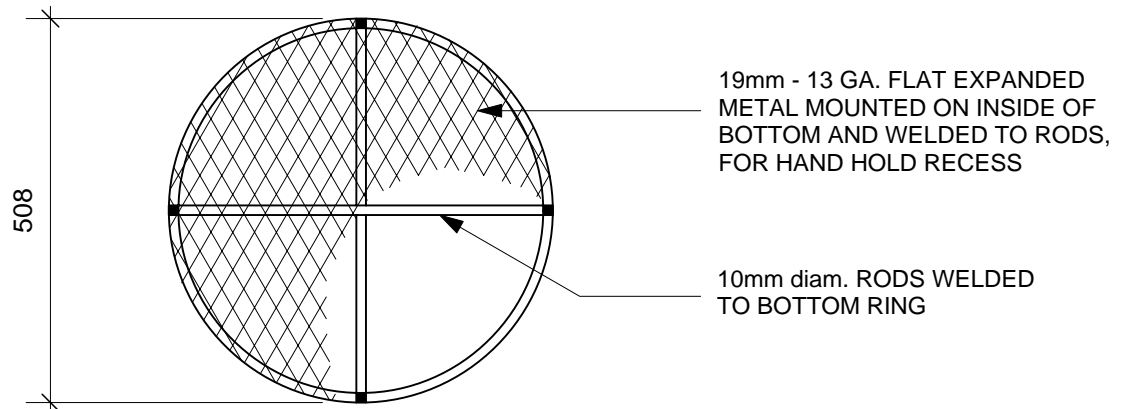

**BOTTOM VIEW**

DIMENSIONS SHOWN ARE IN MILLIMETRES UNLESS OTHERWISE SPECIFIED

REVISION: 1  
DATE: January 12, 2012  
SCALE: N.T.S.  
DRAWN BY: SP

The City of Winnipeg  
Planning, Property and Development Department  
Planning and Land Use Division  
Unit 15 - 30 Fort Street, Winnipeg, MB, R3C 4X5

