

July 4, 2016

Doug Berg
Project Coordinator
Engineering, Water and Waste Department
City of Winnipeg
110-1199 Pacific Ave.

RE: Bid# 445-2016 Shop Drawings-

Supply and Delivery of Large Diameter Butterfly Valves complete with Actuators.

Sincerely,

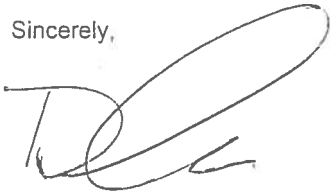

Dan Gilkes
Account Manager
Corix Water Products, Winnipeg

July 8, 2016

Left message with
CORIX to provide
Material list for
the BV components.

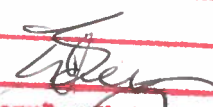
CITY OF WINNIPEG WATER AND WASTE DEPARTMENT DRAWING REVIEW	
<input checked="" type="checkbox"/>	REVIEWED - NO COMMENTS
<input type="checkbox"/>	PROCEED PER COMMENTS, REVISE AND RESUBMIT
<input type="checkbox"/>	REVISE PER COMMENTS AND RESUBMIT BEFORE PROCEEDING
<input type="checkbox"/>	REJECTED
DATE: <u>July 11/16</u>	BY: 
Reviewed only as to general conformity with the design concept, subject to satisfactory installation and performance in place. Responsibility for correct design, details and dimensions remains with the party submitting the drawing.	

K-FLO

BUTTERFLY VALVES FROM



PO BOX 411, BERWICK PA 18603

July 8, 2016

To: Corix
Attn: Bruce James, National Valve Specialist

Project: City of Winnipeg

To Whom It May Concern:

This letter is to certify that K-Flo Series 500 and 47 butterfly valves are manufactured in accordance with the latest edition of AWWA C504 Standard for Rubber-Seated Butterfly Valves.

Kind regards,

Brian J. Lewis

Brian J. Lewis
Vice President/Director of Engineering

Phone: 570-752-4524
Fax: 570-752-4962
e-mail: lewisb@crispinvalve.com

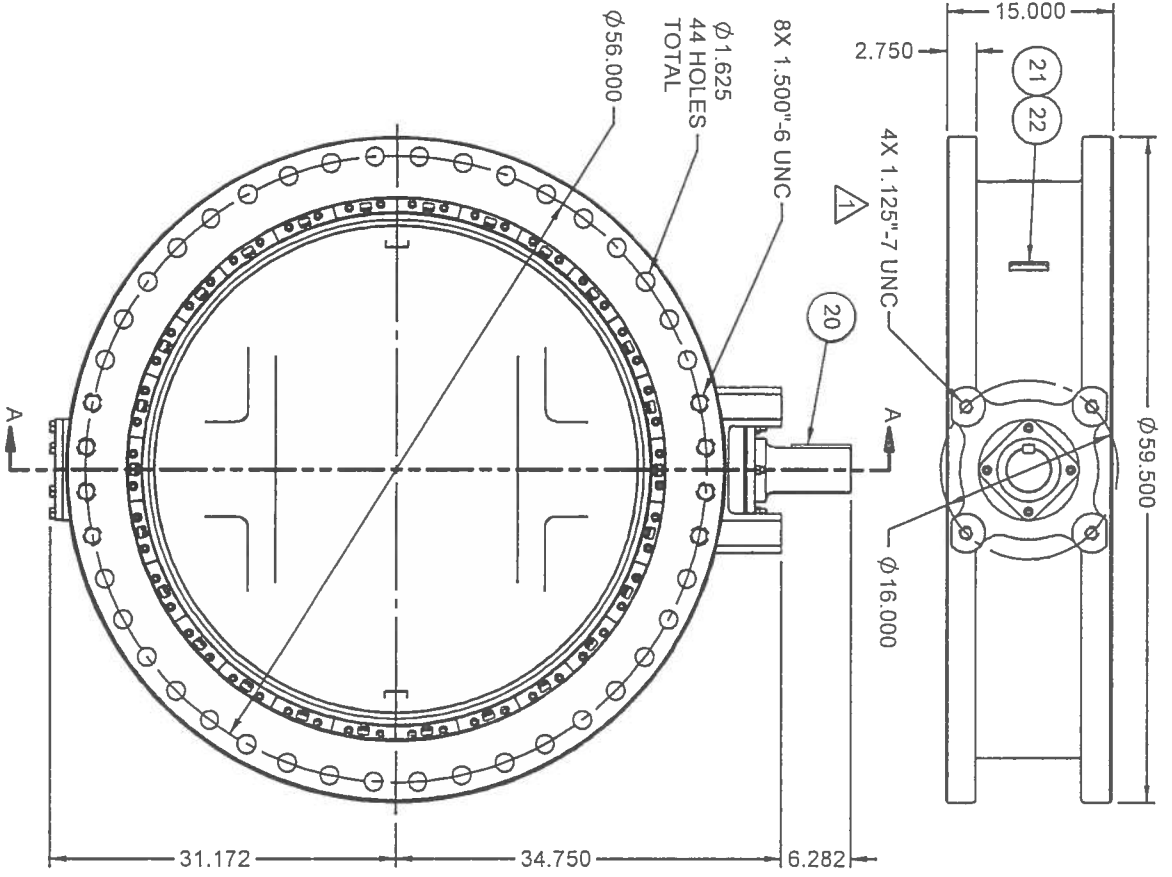

- NOTES:
1. 150 PSIG MAXIMUM WORKING PRESSURE.
 2. THIS VALVE CONFORMS TO AMWA C504.
 3. FLOW RECOMMENDED IN DIRECTION SHOWN.
 4. VALVE MAY BE INSTALLED WITH SHAFT IN EITHER HORIZONTAL OR VERTICAL POSITION.
 5. ALL DIMENSIONS ARE IN INCHES.

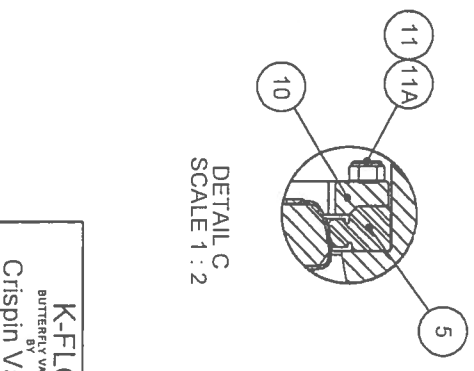
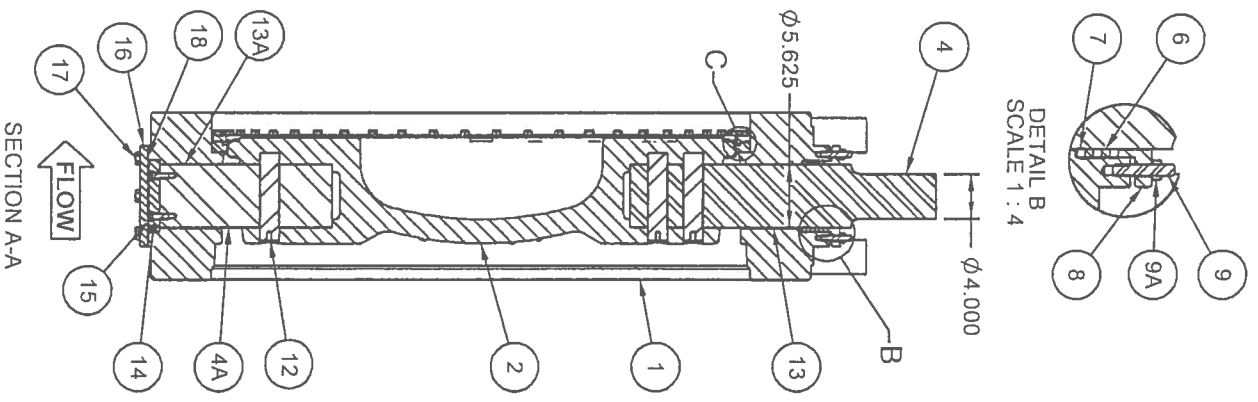

ITEM	QTY	DESCRIPTION
1	1	BODY
2	1	DISC ASSEMBLY
4	1	UPPER SHAFT
4A	1	LOWER SHAFT
5	1	SEAT
6	4	SQUARE-PACKING
7	1	V-TYPE COMPRESS PACKING
8	1	GLAND PLATE
9	4	GLAND STUD
9A	4	GLAND LOCKNUT
10	26	RETAINING RING SEGMENTS
11	52	STUD (RING)
11A	52	HEX NUT (RING)
12	3	SHAFT PIN
13	1	UPPER BUSHING
13A	1	LOWER BUSHING
14	1	THRUST COLLAR
15	2	SCREWS (THRUST COLLAR)
16	1	COVER PLATE (BOTTOM)
17	6	SCREW (COVER PLATE)
18	1	SEAL O-RING
20	1	KEY 1" X 3/4"
21	1	NAMEPLATE
22	2	DRIVE SCREW

REV	DESCRIPTION	DATE	APPROVED
1	WAS 1.500" 7 UNC	12/11/12	

DO NOT SCALE DRAWING
PROPORTIONS SHOULD
MATCH DIMENSIONS SPECIFIED

SCALE: 0.125:1

K-FLO
BUTTERFLY VALVES
BY
Crispin Valves

48"-473 BARE STEM
FLANGED BUTTERFLY
VALVE

REV 1

SHEET 1 OF 1

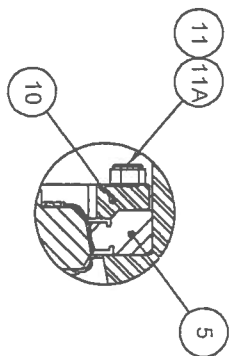
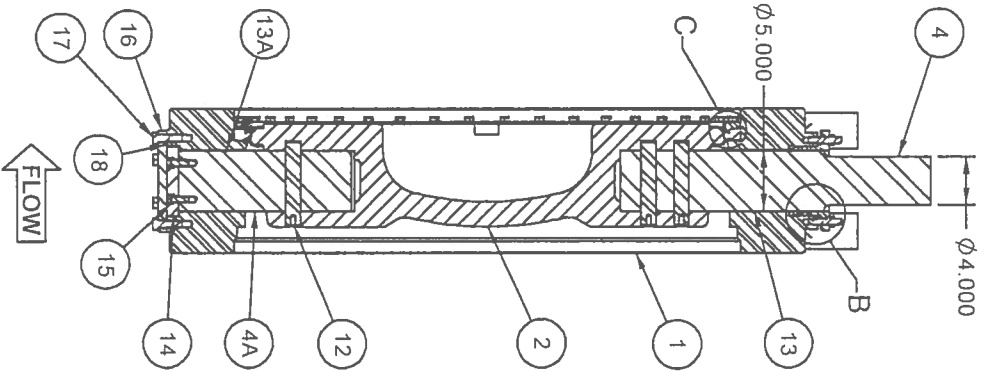
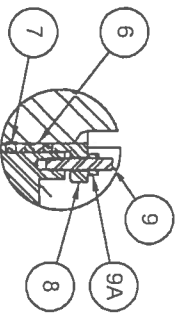
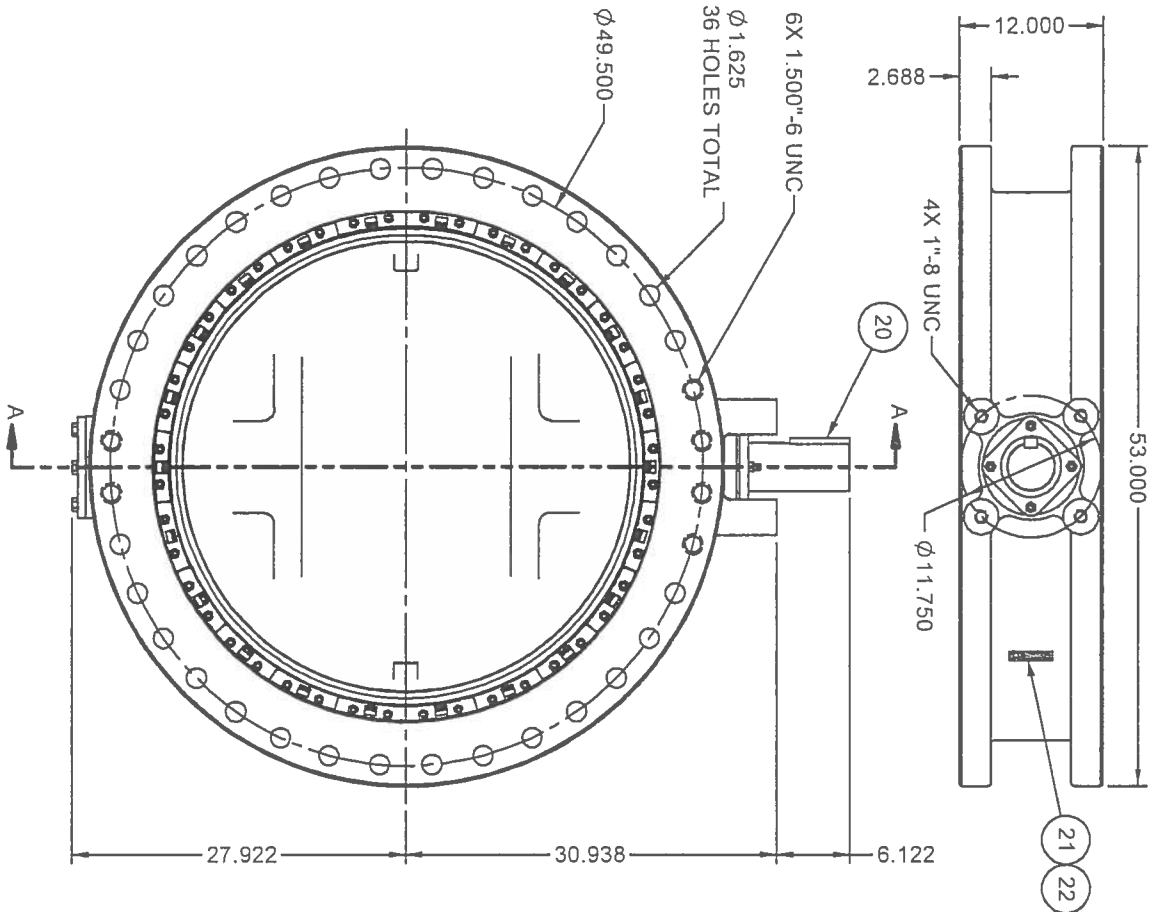

ITEM	QTY	DESCRIPTION
1	1	BODY
2	1	DISC ASSEMBLY
4	1	UPPER SHAFT
4A	1	LOWER SHAFT
5	1	SEAT
6	4	SQUARE-PACKING
7	1	V-TYPE COMPRESS PACKING
8	1	GLAND PLATE
9	4	GLAND STUD
9A	4	GLAND LOCKNUT
10	12	RETAINING RING SEGMENTS
11	24	STUD (RING)
11A	24	HEX NUT (RING)
12	3	SHAFT PIN
13	1	UPPER BUSHING
13A	1	LOWER BUSHING
14	1	THRUST COLLAR
15	2	SCREWS (THRUST COLLAR)
16	1	COVER PLATE (BOTTOM)
17	4	SCREW (COVER PLATE)
18	1	SEAL O-RING
20	1	KEY 1" X 3/4"
21	1	NAMEPLATE
22	2	DRIVE SCREW

- NOTES:
1. 150 PSIG MAXIMUM WORKING PRESSURE.
 2. THIS VALVE CONFORMS TO AWWA C504.
 3. FLOW RECOMMENDED IN DIRECTION SHOWN.
 4. VALVE MAY BE INSTALLED WITH SHAFT IN EITHER HORIZONTAL OR VERTICAL POSITION.
 5. ALL DIMENSIONS ARE IN INCHES.

REV	DESCRIPTION	DATE	APPROVED	DESIGNED	DRAWN	CHECKED	SCALE	SHEET	REV

DO NOT SCALE DRAWING
DIMENSIONS ARE IN INCHES
UNLESS OTHERWISE SPECIFIED

42"-473 BARE STEM
FLANGED BUTTERFLY
VALVE

K-FLO
BUTTERFLY VALVES
BY
Crispin Valves

SCALE: 0.125:1
C 42-473 BS 0
SHEET 1 OF 1

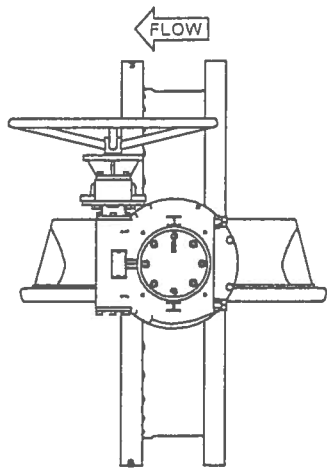

ASS'Y: "B1" (STD. MOUNTING)

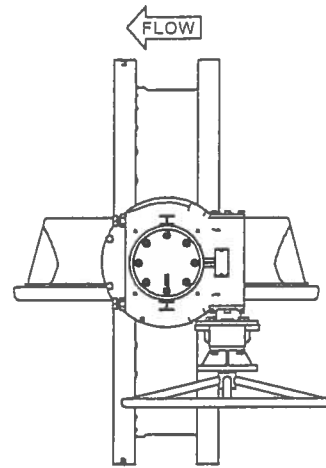

ASS'Y: "B3"

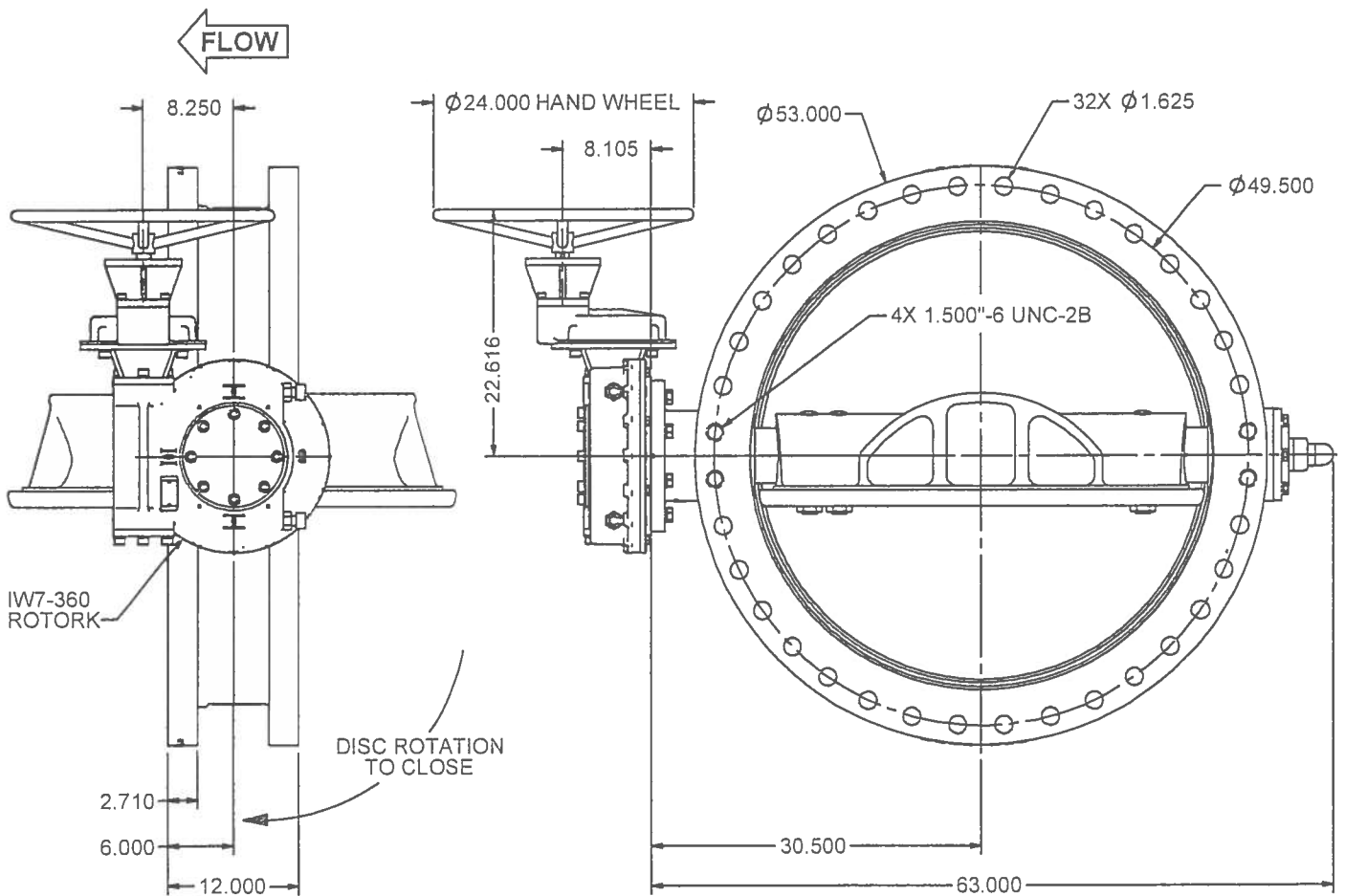

NOTES:

1. 150 PSIG MAXIMUM WORKING PRESSURE.
2. THIS VALVE CONFORMS TO AWWA C504.
3. FLANGE DIMENSIONS & DRILLING COMPLIES TO ASME B16.1 CL. 125.
4. FLOW RECOMMENDED IN DIRECTION SHOWN. (SEAT DOWNSTREAM)
5. VALVE MAY BE INSTALLED WITH SHAFT IN EITHER HORIZONTAL OR VERTICAL POSITION.
6. ROTATE HAND WHEEL CLOCKWISE TO CLOSE VALVE.
7. ALL DIMENSIONS ARE IN INCHES.

K-FLO
 BUTTERFLY VALVES
 BY
 CRISPIN VALVES
 42"-474 FLANGED
 DOVETAIL SEAT BFV WITH
 ROTORK IW7R-360
 AND 24" HAND WHEEL

REV	DATE	BY	APPD	REVISION	REDRAWN:	CHECKED:	DRAWN:	DATE	SIZE	DWG. NO.	REV
							C GEARY	04/29/10	C	42-474 IW7 HW 300	0

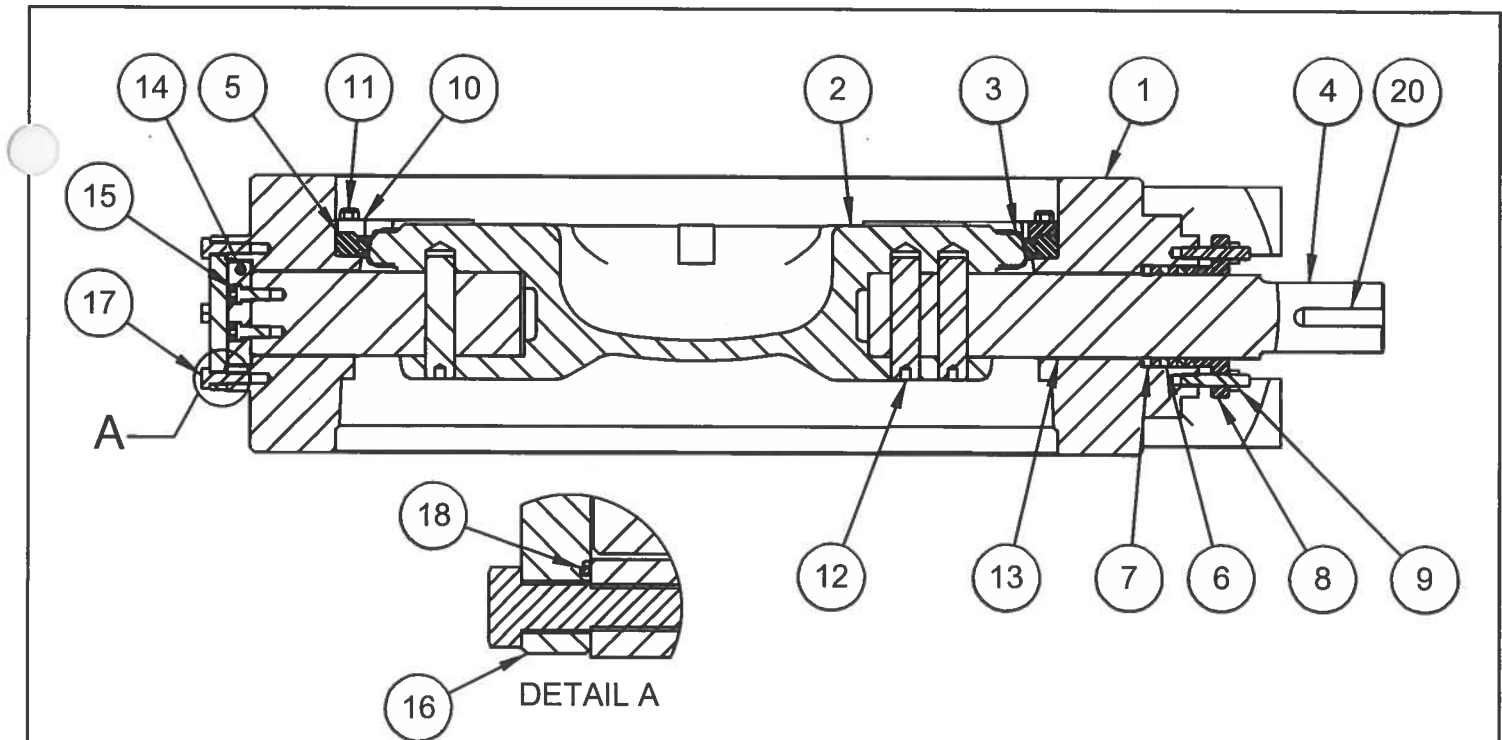

ITEM	DESCRIPTION	MATERIAL	REMARKS
1	BODY	CAST IRON	ASTM A126 CLASS B
2	DISC	DUCTILE IRON	ASTM A536 GR. 65-45-12
3	DISC EDGE	316 STAINLESS STEEL	ASTM A240 TYPE 316
4	UPPER & LOWER SHAFT	304 STAINLESS STEEL	ASTM A276 TYPE 304
5	SEAT	BUNA-N	ASTM D2000
6	PACKING	TEFLON COMPOSITE FIBER	PALMETTO NO. 1392-H OR EQUIV.
7	V-TYPE COMPRESS PACKING	BUNA-N	ASTM D2000
8	GLAND PLATE	RED BRASS	ASTM B62 UNS C83600
9	STUDS & NUTS (GLAND)	304 STAINLESS STEEL	ASTM A276 TYPE 304
10	RETAINING RING SEGMENTS	316 STAINLESS STEEL	ASTM A743 GRADE CF8M
11	STUDS & NUTS (RING)	304 STAINLESS STEEL	ASTM A276 TYPE 304
12	SHAFT PIN	410 STAINLESS STEEL	ASTM A276 TYPE 410
13	BEARING	TFE - 316 STAINLESS STEEL BACKING	TFE/ASTM A240 TYPE 316
14	THRUST COLLAR	304 STAINLESS STEEL	ASTM A240 TYPE 304
15	SCREWS (THRUST COLLAR)	304 STAINLESS STEEL	ASTM F594 GRADE 1
16	COVER PLATE (BOTTOM)	410 STAINLESS STEEL	ASTM A240 TYPE 410
17	SCREW (COVER PLATE)	304 STAINLESS STEEL	ASTM A193 GRADE B8
18	SEAL O-RING	BUNA-N	ASTM D2000
20	KEY	CARBON STEEL	ASTM A108 UNS G10180

K-FLO AWWA BUTTERFLY VALVES FROM CRISPIN VALVES		TITLE: CROSS-SECTION & MATERIAL LIST FOR 24" TO 72", FLANGED BUTTERFLY VALVE FIGURE 473	
DWN. BY: BJL	DATE: 2005 8-11		DWG. NO. 101473-ML
DATE:	APPD BY:		REV. 1
SIZE: A		SHEET 1 OF 1	

1	2009 06-18	CTG		REVISED PARTS LIST AND MATERIALS
REV.	DATE	BY	APPD	REVISION

Drawing Number
GA-00399-R-1

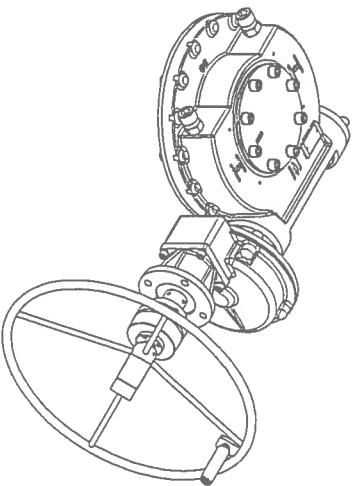
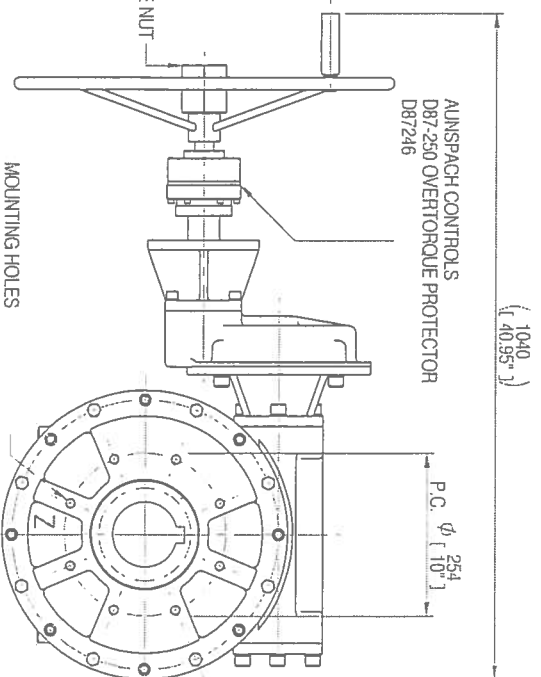
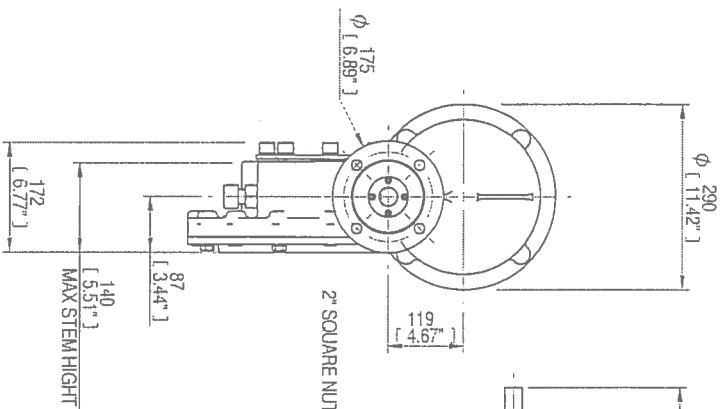
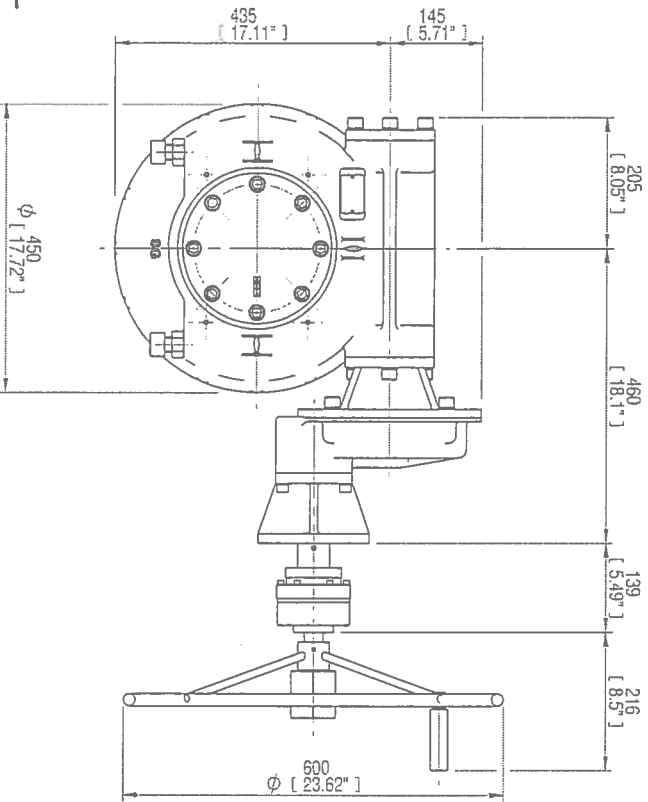

ISOMETRIC VIEW
1:1:1

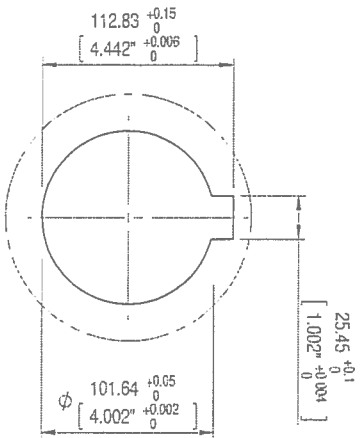

Z
1:3

Iss.	01	EC	Revised	Checked	Approved	Date	6/16/2016	Change Description	FIRST ISSUE
Iss.									

53 PART OF CCHINAKOS PRODUCT DEVELOPMENT. ALL DETAILS SUBJECT TO CHANGE WITHOU PRIOR NOTICE. FOR UP TO DATE DETAILS PLEASE VISIT www.rotork.com

rotork
HOUSTON - USA
www.rotork.com

This drawing is confidential and is the property of Rotork Gears and must not be reproduced either wholly or partly. All rights in respect of patents, designs and copyrights are reserved © 2010

Document Type	GA DRAWING	Mass	14.44 kg	Title	WZ7R AWWA 3001 BALLFLWZ VEST B1 W TORQUE BOSS CRISPER VALVE QUOTE CUS02243-00-2
Dimensions in mm	Scale	1:8		Created	06/16/2016
Checked	Manufacture	06/16/2016		Checked	06/16/2016
Approved				Drawing Number	GA-00399-R-1
				Sheet	1 of 1
				Size	A3

GA-00399-R-1

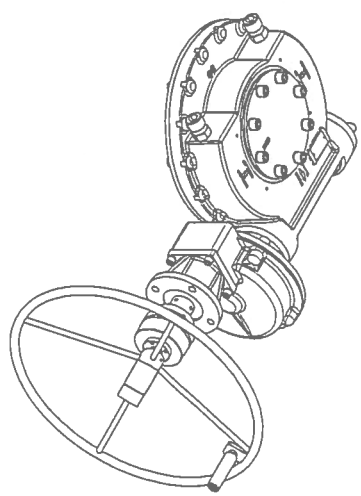
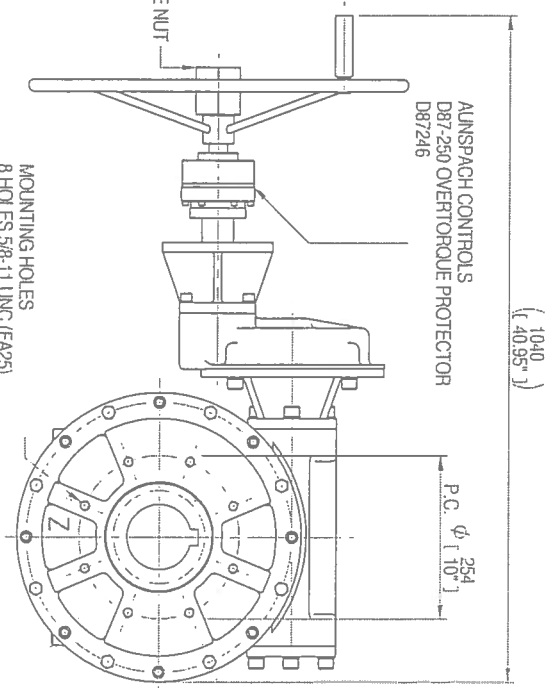
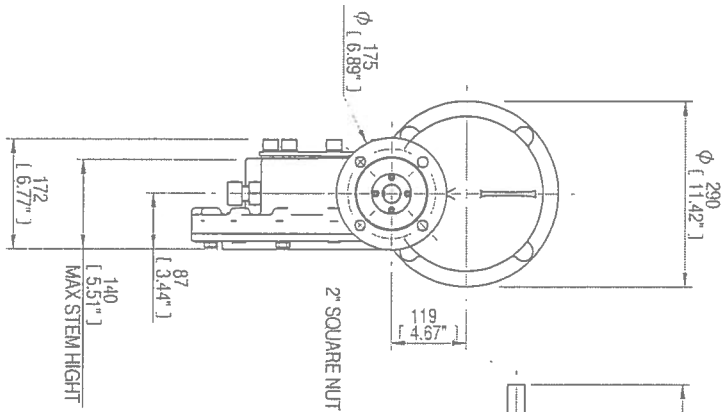
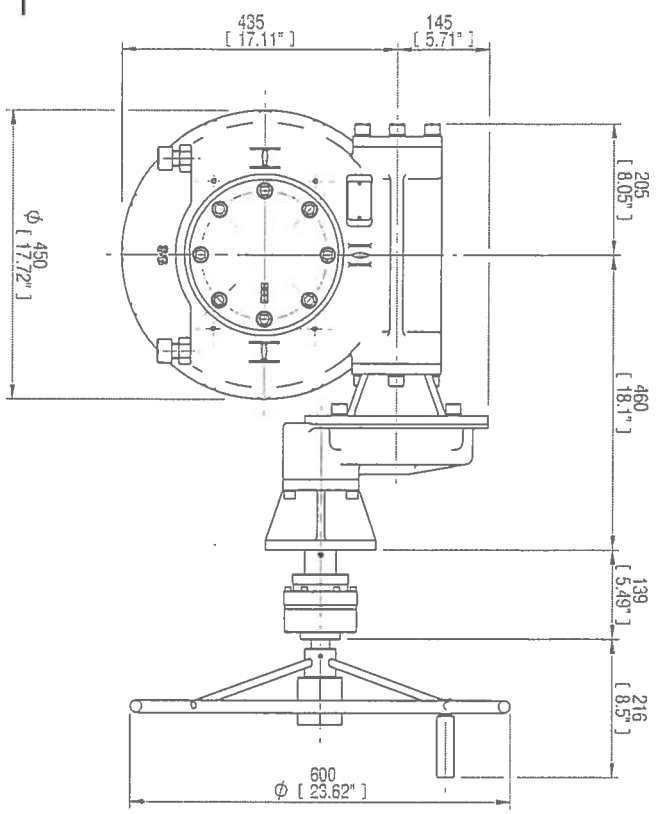

ISOMETRIC VIEW
1:11

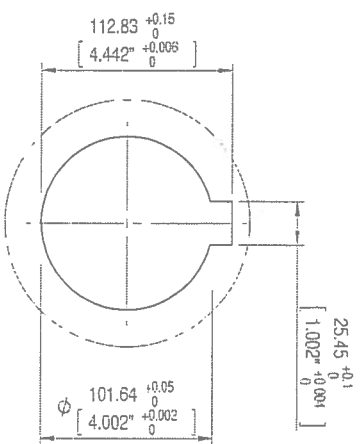

Z
1:3

Rev 05	F		E	D	C	B	A
01	EC	Revised	Checked	Approved	Date	Change Description	
					6/16/2016	FIRST ISSUE	
<p>AS PART OF CONTINUOUS PRODUCT DEVELOPMENT, ALL DETAILS SUBJECT TO CHANGE WITHOUT PRIOR NOTICE. FOR UP TO DATE DETAILS PLEASE VISIT WWW.ROTORK.COM</p>							
<p>rotork GEARTECH HOUSTON - USA www.rotork.com</p>		<p>This drawing is the confidential and is the property of Rotork Gears and must not be reproduced either wholly or partly. All rights in designs and copyrights are reserved. © 2010</p>					
Document Type	GA DRAWING	Mass	144.44 kg	Title			
Dimensions	in mm	Scale		1:8			
Created	06/16/2016	Scan/Revision	06/16/2016	Drawing Number			
Checked	06/16/2016	Date		GA-00399-R-1			
Approved		Sheet	1 of 1	Size	A3		
							Iss. 1

K-FLO

BUTTERFLY VALVES

INSTALLATION AND MAINTENANCE FOR SERIES 47 K-FLO BUTTERFLY VALVES

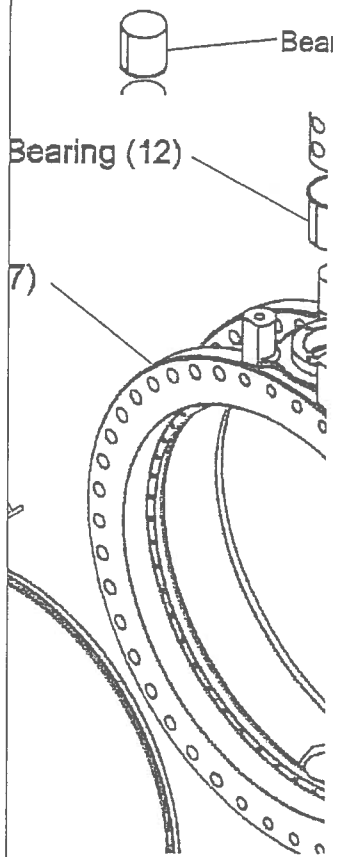
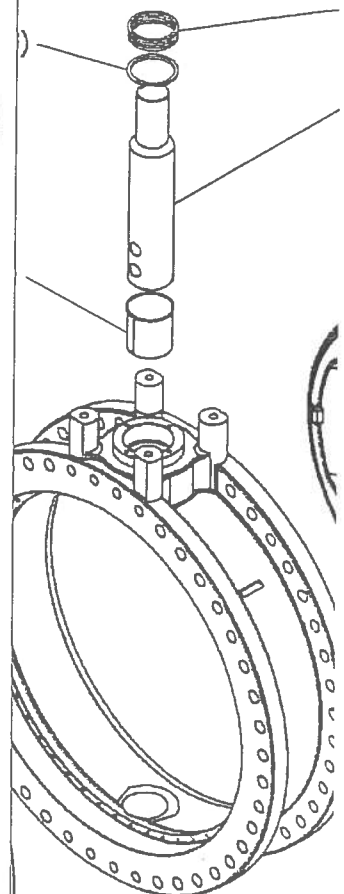
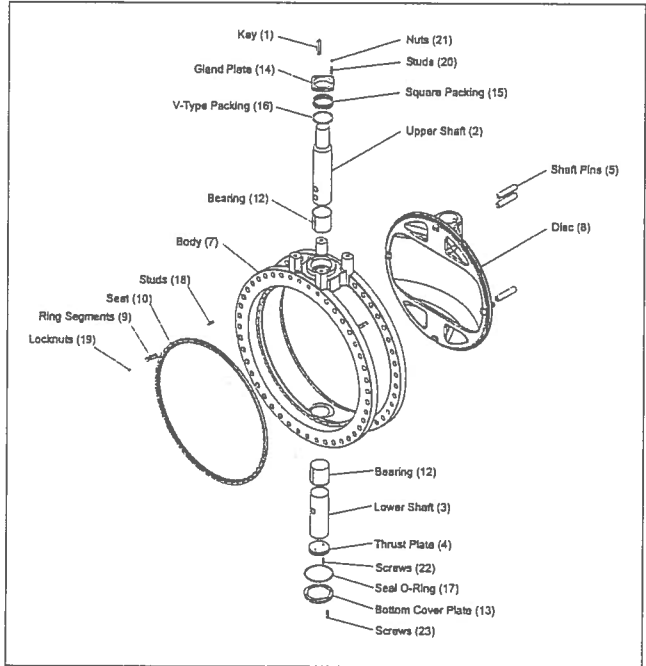
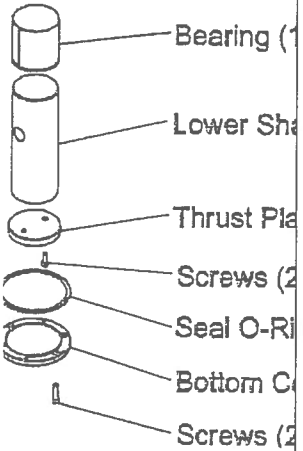
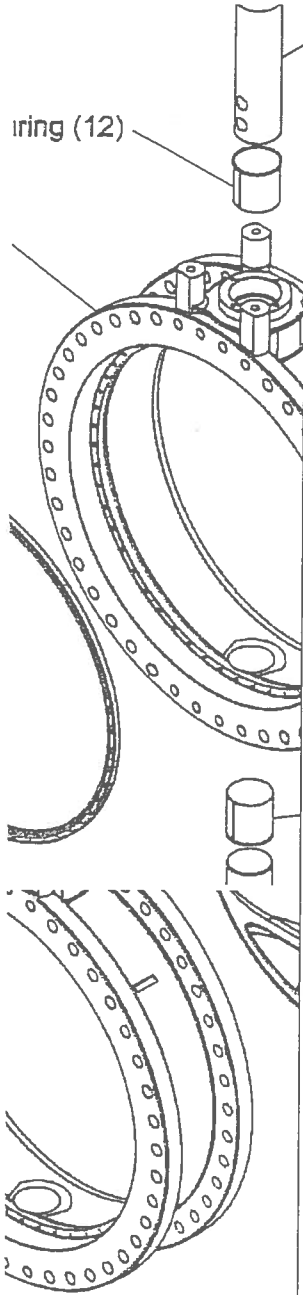

PO Box 411
Berwick PA 18603

800-247-VALV
www.crispinvalve.com

Product Introduction -- K-FLO Series 47: 24"-168"

Instructions

These instructions are intended for personnel who are responsible for the installation, operation and maintenance of your K-FLO AWWA butterfly valve.

Safety Messages

All safety messages herein are flagged with the word Caution, Warning or Danger. These messages must be followed to avoid equipment damage, personal injury or death.

Safety label(s) on the product indicate hazards that can cause equipment damage, personal injury or death. If a safety label becomes difficult to see, or if a label has been removed, please contact Crispin Valve for replacement.

Personnel involved in the installation or maintenance of valves should be constantly alert to the potential emission of process material and take appropriate safety precautions. Always wear suitable protection when dealing with hazardous process materials. Handle valves which have been removed from service with the assumption that process material could be present within the valve.

Inspection

Your AWWA butterfly valve has been packed to provide protection during shipment. Inspect the unit for damage upon arrival and file a carrier claim if damage is apparent.

Parts

Order parts from your local sales representative, or directly from Crispin Valve.

Crispin Valve Service

Crispin service personnel are available to install, maintain and repair all Crispin Valves and products. Crispin also offers customized training programs and consultation services. For more information, contact your local Crispin/K-FLO Valve sales representative or visit our website at www.crispinvalve.com

Table of Contents

Description	A
Flange Requirements	A
Installation Instructions.....	C
Parts Identification.....	B
Installation Adjustments	C
Maintenance and Repair	D
Lubrication.....	D
Seat Replacement	D
Seat Adjustment.....	D
Shaft Bearing Replacement.....	E
Disc/Stem Replacement	F
Recommended Storage Procedures.....	F
Troubleshooting.....	G

Description

K-FLO AWWA Butterfly Valves are heavy-duty, rubber seated butterfly valves in full compliance with AWWA C-504 for use in municipal water treatment, power generation, and industrial applications. K-FLO valves utilize bearings that are of the self-lubricating type which provide strength and low friction for easy operation and lifetime service. No special periodic maintenance is necessary.

Maintenance

This valve is assembled using standard SAE fasteners. To service this valve, you should have a full set of combination wrenches, flat tipped screwdrivers, allen wrenches, a torque wrench, sockets, chisels, a hooked tool for removing the packing and a dead blow hammer. Periodic lubrication is not necessary with the basic valve. See the actuator and accessory instructions for any lubrication requirements these assemblies may have.

Flange Requirements

The K-FLO Butterfly Valves are designed for installation between ANSI B16.1 Class 125# flat faced flanges. Mechanical joint valves are designed for use with AWWA C111 end connections. MJ accessories for the pipe used must be supplied by the installing contractor. Class 250 valves can be ordered with either ANSI B16.1 250# drilling, ANSI B16.1 125# drilling or AWWA C111 MJ ends.

K-FLO Series 47--Installation Instructions

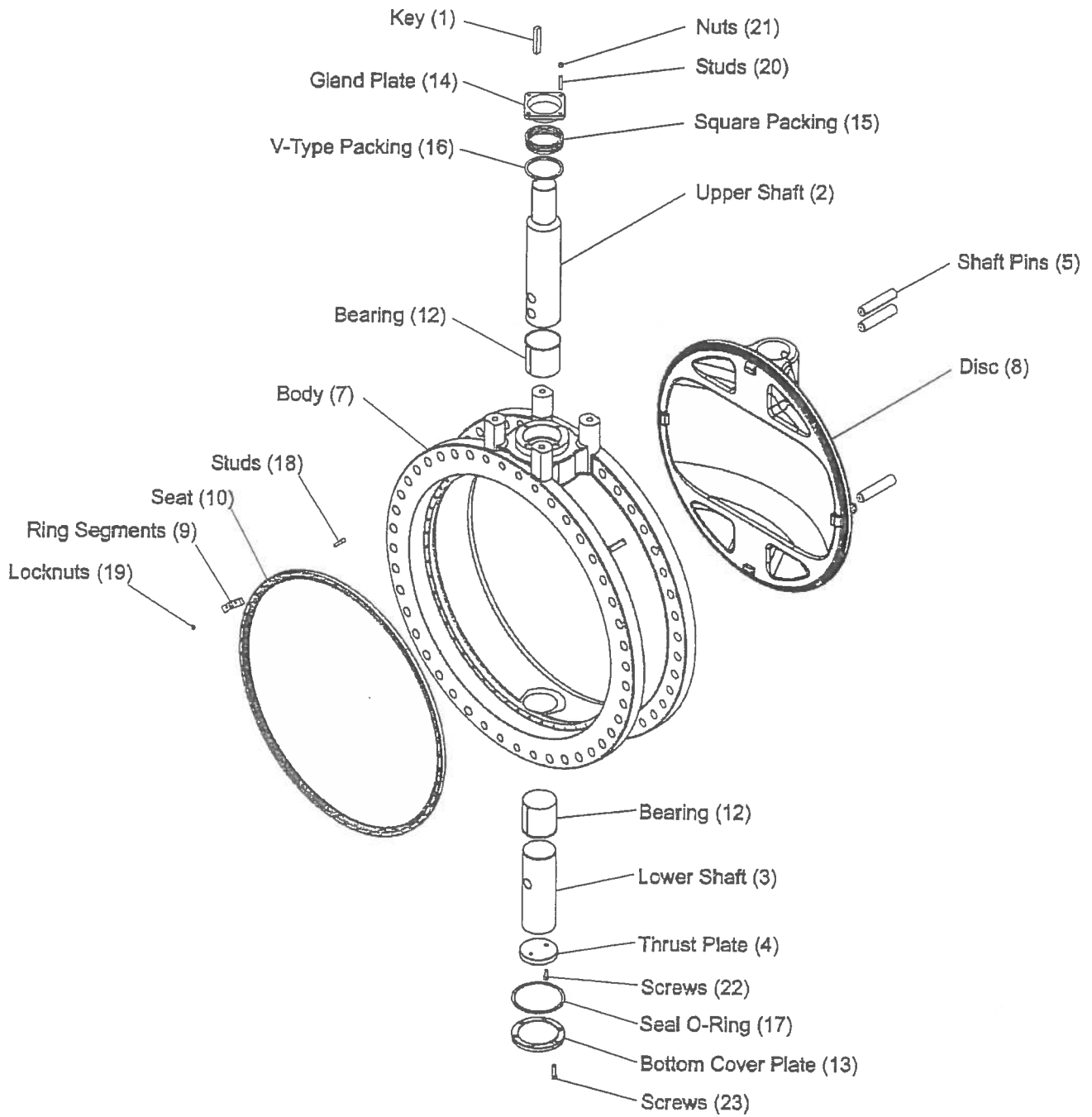

K-FLO Series 47--Installation Instructions

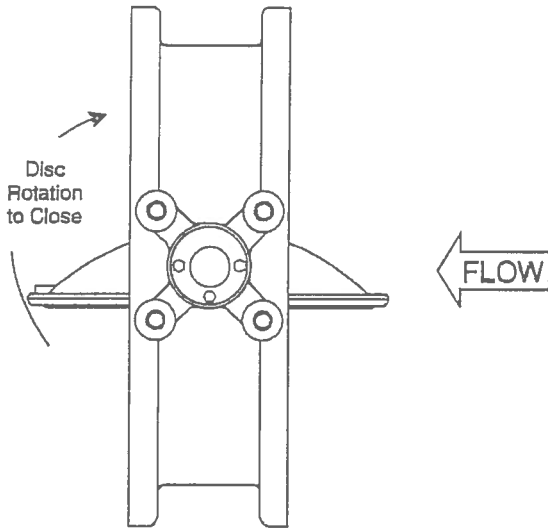

Figure 1--Flow Direction

Installation Instructions

Failure to lift the valve properly may cause damage.

Lift the valve with non-metallic slings fastened around the valve mounting plate, or attach them to bolts or rods run through the flange bolt holes.

Do not fasten lifting devices to the actuator or disc, or through the seat opening in the body.

Note: The Valve disc must be in the closed or nearly closed position, before installation of the valve in the pipeline. This is done to protect the disc seating edge. The valve may be installed with the flow in either direction; however, seat adjustment is facilitated when the flat side of the disc is positioned downstream (see Figure 1).

The valve shaft axis may be either vertical or horizontal. If possible, the valve should be located at least six diameters downstream of all pump, elbows, or tees (see Figure 2).

Installation Adjustments

All Series 47 valves are adjusted and tested at the factory in accordance with AWWA-C-504's latest revision. However, small leaks due to distortion from installation or piping stresses may occur. Such leaks may be stopped by slight tightening (usually a 1/4 turn) of the seat adjusting nut(s) at the leak location (see Figure 4).

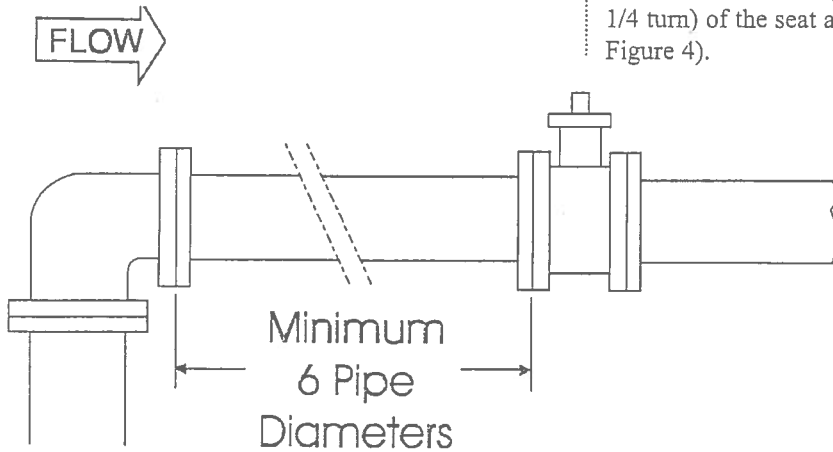

Figure 2--Valve Location

WARNING: Moving Parts from accidental operation of power actuator can cause personal injury or equipment damage. Disconnect and lock out power to actuator before servicing.

WARNING: The valve is a pressure vessel. Good maintenance and practice dictates that the valve must be depressurized prior to performing maintenance. Isolate the valve in the pipeline by closing the valve that is just upstream, and then the valve that is just downstream (in that order) prior to performing maintenance.

Maintenance and Repair

Lubrication:

No routine lubrication is required. The bushings are permanently lubricated. Silicone grease (DOW III or equivalent) is required during seat replacement/adjustment.

Replacement of Shaft Packing

(see Figure 5).

1. Remove the gland nuts (21) and slide the gland plate (14) up along the upper shaft (2)
2. Carefully pry out the old packing rings.
3. Install the new V-Type packing (16).
4. Install new square packing (15), alternating the packing joints on opposite sides of the shaft.
5. Replace the gland plate (14) and gland nuts (21), tightening evenly until the packing is compressed about 1 mm. At this point, you may pressurize the valve and tighten the packing gland until leakage stops.



CAUTION: Do not over-tighten the packing gland nuts. Doing so will increase torque and may cause premature seal failure.

Figure 4--Shaft Adjustment

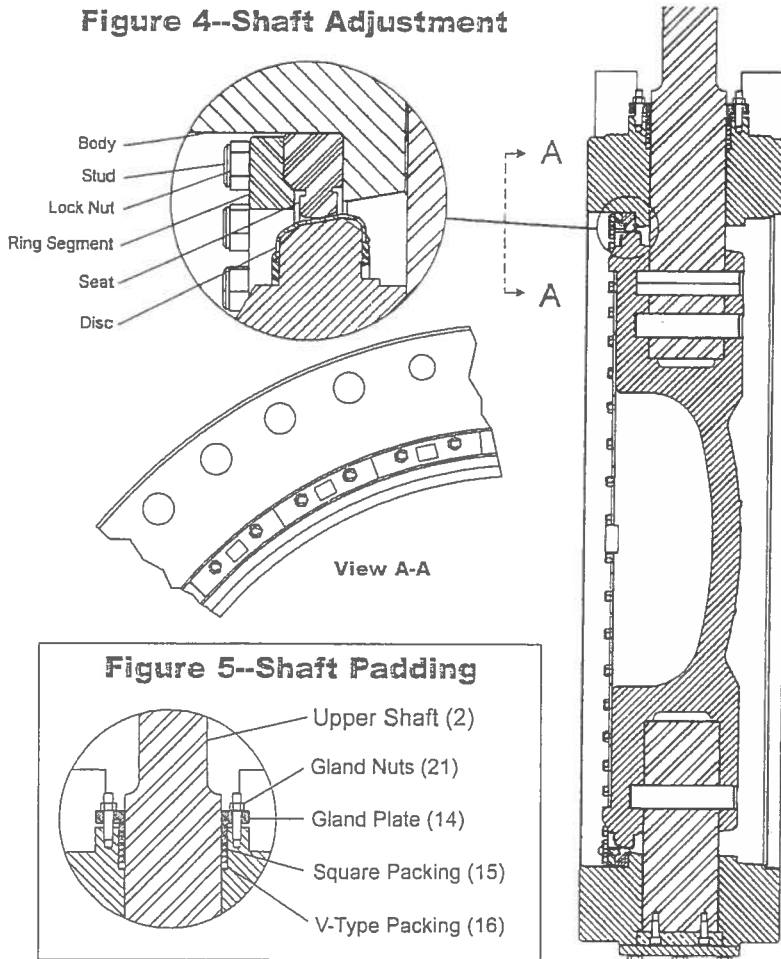

Seat Replacement (see page B)

The seat (10) may be replaced with the valve open or closed and while the valve is in the pipeline.

1. Remove the locknuts (19) and ring-segments (9) from studs (18). A box or open-end wrench is required if the valve is in the pipeline.
2. Pry the old seat (10) off of the studs (18) with a screwdriver or similar tool. Take care not to damage the disc (8) seating edge.
3. Install the replacement seat (10) over the studs (18) with the beveled base toward the ring segments (9).
4. Replace ring segments (9) and install lock-nuts (19). (See "Seat Adjustment" for adjusting the seat.)

Seat Adjustment (New Seat):

1. Replace seat (10) per "Seat Replacement" procedures.
2. Open the valve disc. Clean and lubricate the seat and seat surface on the disc edge with silicone grease (DOW III or equal).
3. Close valve disc completely.

K-FLO Series 47--Maintenance and Repair

Maintenance And Repair Continued

Seat Adjustment (Existing Seat):

4. Torque all locknuts (19) to 75 in/lbs in a clockwise circular pattern and then to 150 in/lbs.
5. Apply water up to test pressure rating.
6. Note location of leakage. Select one locknut (19) where leakage is occurring and tighten by a 1/4 to 1/3 revolution. Bypass locknuts (19) where there is no leakage. Continue clockwise around the valve, tightening each locknut by a 1/4 to 1/3 revolution where leakage is occurring. Continue this process until the last leak has been stopped. See Table A below for locknut torques.

Existing seat with test water pressure.

Note location of leakage. Select locknut (19) where leakage is occurring and tighten by 1/4 to 1/3 revolution, bypassing locknuts (19) where there is no leakage. Continue clockwise around the valve, tightening each locknut by a 1/4 to 1/3 revolution where leakage is occurring. Continue this process until the last leak has been stopped. See Table A below for locknut torques.

Table A
Locknut Torques

Valve Pressure Rating	Locknut Torque Range
Class 150B	150-250 in-lbs
Class 250B	150-300 in-lbs

Note: The minimum torque required to achieve a seal at the seat should be used as it lowers valve operating torque and extends seat life.

Shaft Bearing Replacement

Note: The valve must be orientated with the stem's vertical orientation with the disc open in order to remove the bearings.

Top Shaft Bearing

1. Remove actuator. Remove nuts (21), and slide gland plate (14) off the upper shaft (2).
2. Pry out old square packing (15) and remove V-type packing (16).
3. Using a dental pick or similar tool, catch the lip of the bearing (12) and lift while working the bearing out. The bearing may be pushed out from inside the valve to facilitate reaching under the bearing lip.
4. Slide the replacement bearing (12) in place.
5. Replace square packing (15), V-type packing (16) and gland plate (14) as described for replacement of shaft packing.

Bottom Shaft Bearing

1. Remove bottom cover (13) and seal o-ring (17).
2. Remove screws (22) holding the thrust plate (4) to the lower shaft (3).

Maintenance And Repair Continued

3. Using a dental pick or similar tool, catch the lip of the bearing (12) and lift while working the bearing cut. The bearing may be pushed out from inside the valve to facilitate reaching under the bearing lip.
4. Slide the replacement bearing (12) in place.
5. Fasten thrust plate (4) to the lower shaft (3).
6. Replace seal o-ring (17) with a new one and secure the bottom cover plate (13).

Disc/Shaft Replacement

The disc/shaft assembly is drilled and pinned at the factory as a matched set. If replacement of either the disc or stem should be required, Crispin Valve recommends that the valve be returned to the factory for such service.

Recommended Storage Procedures

Long-Term Storage

1. All resilient seated valves shall be stored in the open (unseated) position.
2. All valves with adjustable packing glands should have the packing gland loosened prior to storage.
3. Valves shall be separately packaged in a sealed polyethylene plastic enclosure with a minimum of one package of dessicant inside, dependent upon valve size.
4. Prepared valves shall be warehoused in a clean, dry, indoor facility on concrete or raised racks, with temperature ranging from 35°F to 95°F (2°C to 35°C).
5. Valves shall not be near electric motors or other equipment which may emit Ozone. This can cause deterioration of elastomer components in the valve and actuator.
6. The valves shall be inspected periodically. Replace the dessicant if required, and repair any damage to the polyethylene plastic enclosures.
7. Valves with cylinder operators and controls that are stored for extended periods may be subject to cylinder blow-by caused by permanent distortion of any of the seals. Valves should be operated prior to installation and damaged seals replaced.
8. Valves with electric motor operators shall be stored in accordance with the individual motor manufacture's recommended long-term storage procedures, in addition to Paragraphs 1, 2 and 3 above.
9. All electrical components, if applicable, should be inspected and all electrical contacts cleaned before operation.
10. Valves shall be enclosed in fully sheathed wooden crates or boxes.

Short-Term Storage

1. Valve should be protected from the weather. Avoid exposure to excessive moisture or dirt. Store at temperatures ranging from 35°F to 95°F (2°C to 35°C).

K-FLO Series 47--Troubleshooting

SYMPTOM	POSSIBLE CAUSE	SUGGESTED REMEDY
Valve opens only a few degrees and stops (it will not open to the full angle desired)	Improper Installation. The valve is improperly aligned.	Loosen the flange bolts. Realign the valve with flanges, and retighten the flange bolts to correct torque per ANSI requirements.
	Mating pipe internal diameter or other obstruction is interfering with disc.	Pipe does not meet standards and spacers may be required. Any pipeline or disc obstruction must be removed.
	Actuator not properly installed	Refer to actuator adjustment.
Leakage past the flange face	Flange bolts are not evenly torqued.	Loosen the flange bolts and tighten the flange bolts to correct torque per ANSI requirements.
	Improper flanges	Refer to "Flange Requirements" on page A.
	Improper flange gaskets	Full face flange gaskets required.
Leakage in the closed position (leakage in the pipeline)	The disc is not closing fully: Actuator is not properly adjusted.	Refer to "Actuator Adjustment" procedures.
	Damaged or improperly aligned valve seat	Follow "Seat Adjustment" procedures on page 5, or replace seat if damaged.
	Line pressure exceeds valve's working pressure	Reduce line pressure to valve working pressure.
	Damaged valve disc	Return valve to factory for disc/stem replacement.
Leakage at the valve stem	Packing failure	<ol style="list-style-type: none"> 1. Fully open and close the valve 3 times. 2. Refer to "Replacement of Shaft Packing" on page F.
Water Hammer	The valve is closing too quickly.	Turn actuator slower.
Excessively high torque	Obstruction in the pipeline	Remove valve from pipeline and remove obstruction.
	Valve shaft or disc bent	Return valve to factory for disc/shaft replacement (check for water hammer or freezing of line material).
	Scale buildup on shaft or seat	Open and close the valve several times. Operate the valve at least once a month. Check the valve seat for deterioration.

K-FLO

BUTTERFLY VALVES

VALVES FROM 3" THRU 168"

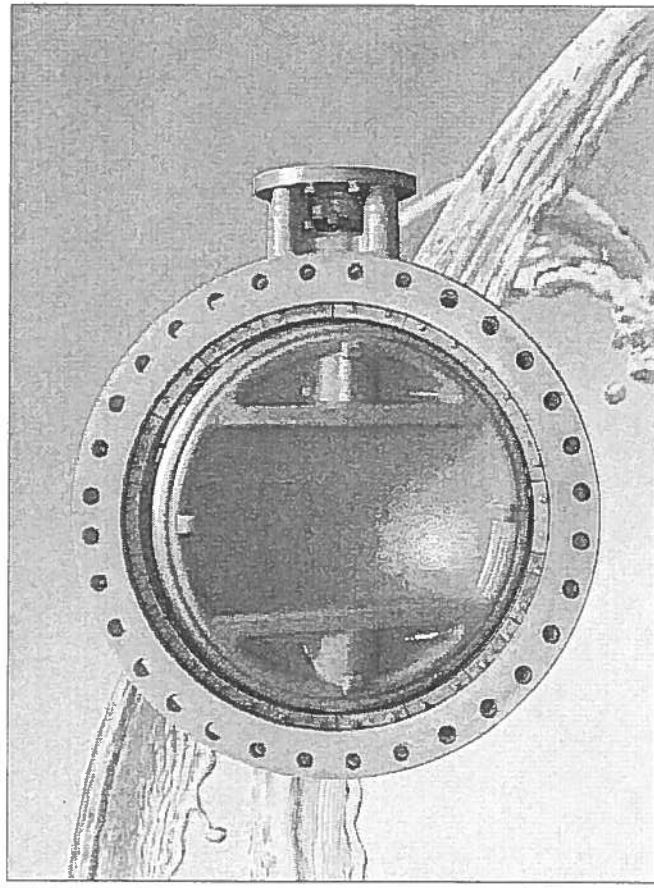

MEETS AND EXCEEDS
THE LATEST AWWA C504 EDITION

Crispin

PO Box 411
Berwick PA 18603

S2 - Shaft Dia., 150B
S3 - Shaft Dia., 250B

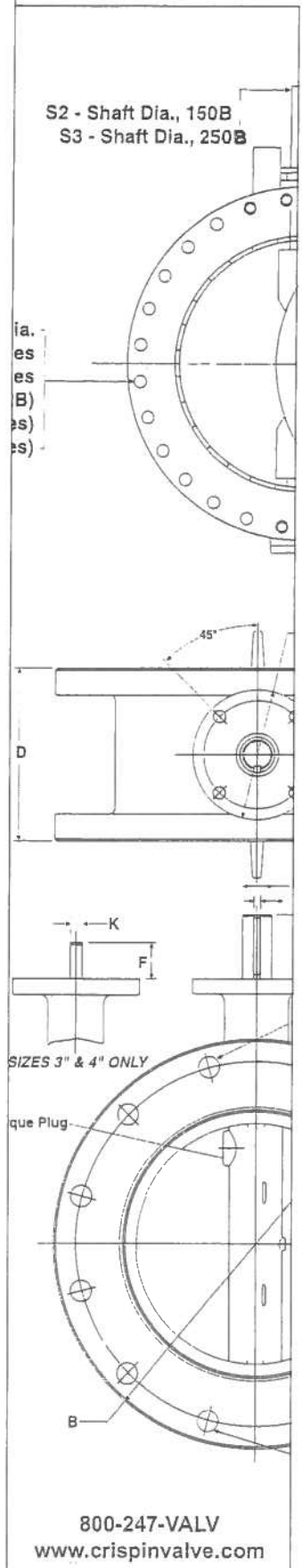
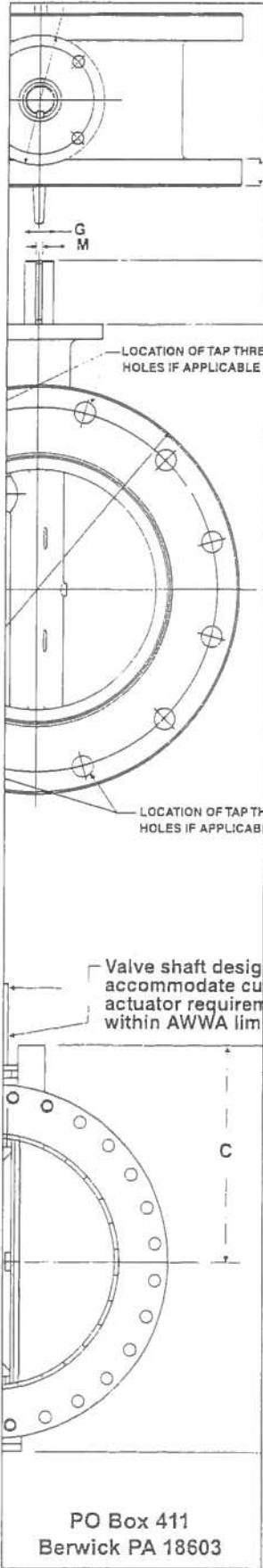

SIZES 3" & 4" ONLY

800-247-VALV
www.crispinvalve.com

500 SERIES: Sizes 3"-20" Available

The K-Flo 500 Series is a heavy-duty resilient seated butterfly valve line in full compliance with AWWA C504 for use in municipal, power and industrial applications. Every K-Flo 500 Series butterfly valve is tested for performance, as well as seat and body leakage; and all of the valves meet or exceed the latest AWWA C504 standards and requirements. The 500 Series valves are available in flanged or mechanical joint configurations.

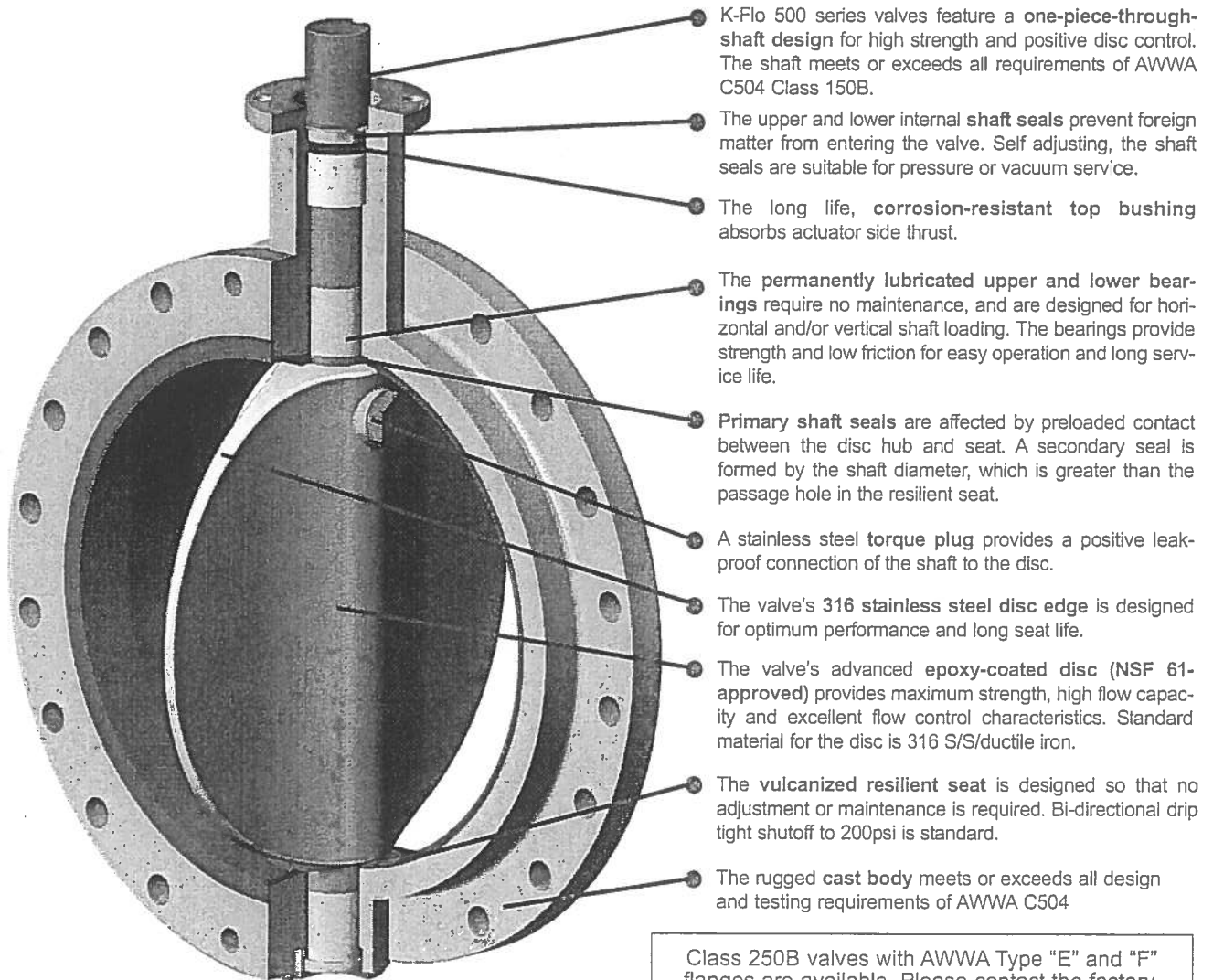

- K-Flo 500 series valves feature a **one-piece-through-shaft design** for high strength and positive disc control. The shaft meets or exceeds all requirements of AWWA C504 Class 150B.
- The upper and lower internal **shaft seals** prevent foreign matter from entering the valve. Self adjusting, the shaft seals are suitable for pressure or vacuum service.
- The long life, **corrosion-resistant top bushing** absorbs actuator side thrust.
- The **permanently lubricated upper and lower bearings** require no maintenance, and are designed for horizontal and/or vertical shaft loading. The bearings provide strength and low friction for easy operation and long service life.
- **Primary shaft seals** are affected by preloaded contact between the disc hub and seat. A secondary seal is formed by the shaft diameter, which is greater than the passage hole in the resilient seat.
- A **stainless steel torque plug** provides a positive leak-proof connection of the shaft to the disc.
- The valve's **316 stainless steel disc edge** is designed for optimum performance and long seat life.
- The valve's advanced **epoxy-coated disc (NSF 61-approved)** provides maximum strength, high flow capacity and excellent flow control characteristics. Standard material for the disc is 316 S/S/ductile iron.
- The **vulcanized resilient seat** is designed so that no adjustment or maintenance is required. Bi-directional drip tight shutoff to 200psi is standard.
- The rugged **cast body** meets or exceeds all design and testing requirements of AWWA C504

Class 250B valves with AWWA Type "E" and "F" flanges are available. Please contact the factory.

MATERIALS

SIZES
3"-20" (meets or exceeds AWWA C504)

BODY
Cast Iron (ASTM A126, Class B); Ductile Iron (optional); (ASTM A536 Grade 65/45/12)

SEAT
Seating of Synthetic Rubber bonded to body. Buna-N standard; EPDM optional (tested in accordance with ASTM D429, Method B)

UPPER STEM BUSHING
Polyester

SHAFT
Stainless Steel (ASTM A276): Grade 304 standard, Grade 316 optional; 17-4pH on Class 250B

DISC
316 Stainless standard on 3"-8". Ductile Iron (ASTM A536, Grade 65-45-12) with a 316 Stainless Steel Edge on sizes 10"-20". Iron discs are coated with an epoxy for extra long product life

BEARINGS
316 Stainless Steel; TFE Lined

500 SERIES: Dimensional Data

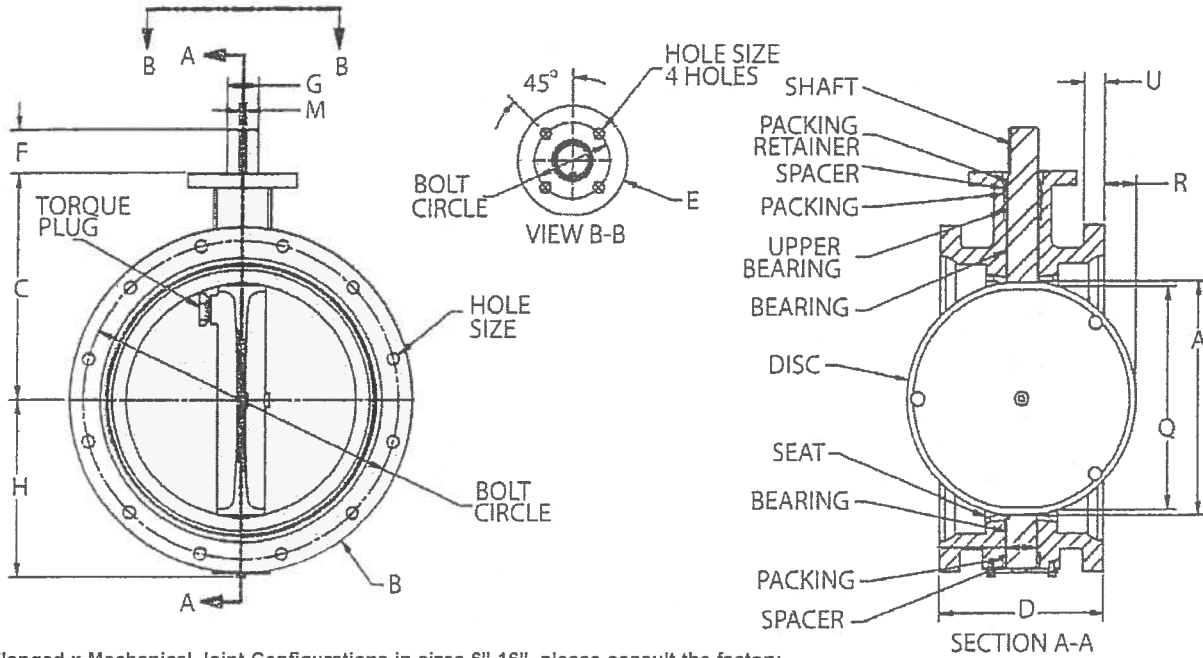

For Flanged x Mechanical Joint Configurations in sizes 6"-16", please consult the factory.

K-FLO Model 504 (Flanged x Flanged)													TOP PLATE		FLANGE DRILLING				Bare Shaft		
All dimensions are in INCHES													Bolt Circle	Hole Size	ISO 5211	Bolt Circle	# of Holes	Hole Size	Tapped Holes	Thread Size	Wt. lbs.
Size	A	B	C	D	E	F	G	H	M Key	Q	R	U									
3	2 ³ / ₄	7 ¹ / ₂	6 ⁵ / ₁₆	5	4	1 ¹ / ₂	9 ⁹ / ₁₆	3 ³ / ₄	1/8sq	n/a	n/a	9 ⁹ / ₁₆	2.756	1 ¹¹ / ₃₂	F 07	6	4	3 ³ / ₄	n/a	n/a	29
4	3 ⁹ / ₁₆	9	7 ¹ / ₁₆	5	4	1 ¹ / ₂	9 ⁹ / ₁₆	4 ¹ / ₂	1/8sq	n/a	n/a	5 ⁵ / ₁₆	2.756	1 ¹¹ / ₃₂	F 07	7 ¹ / ₂	8	3 ³ / ₄	n/a	n/a	48
6	5 ¹ / ₂	11	8 ¹ / ₁₆	5	6	2	1 ¹ / ₈	6	1/4sq	2 ³ / ₄	5 ⁵ / ₁₆	1 ¹ / ₈	4.921	9 ⁹ / ₁₆	F 12	9 ¹ / ₂	8	7 ⁷ / ₈	n/a	n/a	58
8	7 ¹ / ₂	13 ¹ / ₂	9 ⁹ / ₁₆	6	6	2	1 ¹ / ₈	6 ³ / ₄	1/4sq	4 ⁷ / ₈	1 ³ / ₁₆	1 ¹ / ₈	4.921	9 ⁹ / ₁₆	F 12	11 ³ / ₄	8	7 ⁷ / ₈	n/a	n/a	96
10	9 ⁵ / ₈	16	10 ¹³ / ₁₆	8	6	2 ¹ / ₂	1 ³ / ₈	8	5 ⁵ / ₁₆ sq	5 ³ / ₈	1 ³ / ₁₆	1 ³ / ₈	4.921	9 ⁹ / ₁₆	F 12	14 ¹ / ₄	12	1	n/a	n/a	150
12	11 ³ / ₈	19	12 ⁵ / ₁₆	8	6	2 ⁹ / ₁₆	1 ³ / ₈	9 ¹ / ₂	5 ⁵ / ₁₆ sq	8 ³ / ₈	1 ¹¹ / ₁₆	1 ¹ / ₂	4.921	9 ⁹ / ₁₆	F 12	17	12	1	n/a	n/a	204
14	12 ¹⁵ / ₁₆	21	14 ¹ / ₁₆	8	8	2 ³ / ₈	1 ⁵ / ₈	10 ¹ / ₂	3/8sq	10 ¹ / ₂	2 ¹ / ₂	1 ³ / ₄	6.496	1 ³ / ₁₆	F 16	18 ³ / ₄	12	1 ¹ / ₈	n/a	n/a	267
16	15 ¹ / ₈	23 ¹ / ₂	15 ¹ / ₁₆	8	8	2 ¹¹ / ₁₆	1 ⁷ / ₈	11 ³ / ₄	1/2 x 3/8	13 ¹ / ₈	3 ⁵ / ₈	2	6.496	1 ³ / ₁₆	F 16	21 ¹ / ₄	16	1 ¹ / ₈	4	1"-8	354
18	16 ¹⁵ / ₁₆	25	16 ⁹ / ₁₆	8	8	3 ³ / ₁₆	2 ¹ / ₄	13 ¹ / ₁₆	1/2 x 3/8	15 ¹ / ₁₆	4 ⁹ / ₁₆	2 ¹ / ₄	6.496	1 ³ / ₁₆	F 16	22 ³ / ₄	16	1 ¹ / ₄	4	1 ¹ / ₈ "-7	433
20	18 ⁷ / ₈	27 ¹ / ₂	18 ¹ / ₁₆	8	8	3 ³ / ₁₆	2 ¹ / ₄	14 ⁵ / ₁₆	1/2 x 3/8	17 ³ / ₈	5 ¹ / ₂	2 ¹ / ₂	6.496	1 ³ / ₁₆	F 16	25	20	1 ¹ / ₄	4	1 ¹ / ₈ "-7	586

K-FLO Model 506 (Mechanical Joint x Mechanical Joint)													TOP PLATE		FLANGE DRILLING				Bare Shaft		
All dimensions are in INCHES													Bolt Circle	Hole Size	ISO 5211	Bolt Circle	# of Holes	Hole Size	Wt. lbs.		
Size	A	B	C	D	E	F	G	H	M Key	Q	R	U									
6	5 ¹ / ₂	11 ¹ / ₂	8	8 ¹ / ₂	6	2 ¹ / ₁₆	1 ¹ / ₈	6	1/4sq	4 ¹ / ₂	n/a	1 ¹ / ₈	4.921	9 ⁹ / ₁₆	F 12	9 ¹ / ₂	6	7 ⁷ / ₈			80
8	7 ¹ / ₂	13 ³ / ₄	9 ¹ / ₂	8 ⁵ / ₈	6	2	1 ¹ / ₈	8 ⁷ / ₈	1/4sq	6 ³ / ₄	n/a	1 ¹ / ₈	4.921	9 ⁹ / ₁₆	F 12	11 ³ / ₄	6	7 ⁷ / ₈			120
10	9 ⁵ / ₈	16 ¹ / ₁₆	10 ³ / ₄	9 ¹ / ₄	6	2 ⁹ / ₁₆	1 ³ / ₈	8	5 ⁵ / ₁₆ sq	8 ³ / ₄	3 ³ / ₁₆	1 ³ / ₈	4.921	9 ⁹ / ₁₆	F 12	14	8	7 ⁷ / ₈			170
12	11 ³ / ₈	18 ⁵ / ₁₆	12 ¹ / ₄	9 ¹ / ₄	6	2 ⁹ / ₁₆	1 ³ / ₈	9 ³ / ₁₆	5 ⁵ / ₁₆ sq	10 ⁹ / ₁₆	1 ¹ / ₁₆	1 ¹ / ₂	4.921	9 ⁹ / ₁₆	F 12	16 ¹ / ₄	8	7 ⁷ / ₈			230
14	12 ¹⁵ / ₁₆	20 ¹¹ / ₁₆	14	11 ¹ / ₂	8	2 ⁷ / ₁₆	1 ⁵ / ₈	10 ³ / ₈	3/8sq	12 ¹³ / ₁₆	3 ³ / ₄	1 ³ / ₄	6.496	1 ³ / ₁₆	F 16	18 ³ / ₄	10	7 ⁷ / ₈			300
16	15 ¹ / ₈	22 ¹⁵ / ₁₆	15	12	8	3	1 ⁷ / ₈	11 ⁷ / ₁₆	1/2 x 3/8	14 ⁵ / ₁₆	1 ⁵ / ₈	2	6.496	1 ³ / ₁₆	F 16	21	12	7 ⁷ / ₈			390
18	16 ¹⁵ / ₁₆	25 ¹ / ₄	16 ¹ / ₂	12 ¹ / ₄	8	3 ³ / ₁₆	2 ¹ / ₄	13 ¹ / ₁₆	1/2 x 3/8	16 ³ / ₁₆	2 ³ / ₈	2 ¹ / ₄	6.496	1 ³ / ₁₆	F 16	23 ¹ / ₄	12	7 ⁷ / ₈			470
20	18 ⁷ / ₈	27 ⁷ / ₁₆	18	12 ¹ / ₂	8	3 ³ / ₁₆	2 ¹ / ₄	14 ⁵ / ₁₆	1/2 x 3/8	18 ¹ / ₁₆	3 ³ / ₁₆	2 ¹ / ₂	6.496	1 ³ / ₁₆	F 16	25 ¹ / ₄	14	7 ⁷ / ₈			630

FLANGED X FLANGED; MECHANICAL JOINT X MECHANICAL JOINT

• "Q" Dimension is the min. allowable inside pipe diameter at the centered valve body face to protect the disc sealing edge from damage when opening valve.

• Flange drilling per ANSI B16.1 Class 125

47 SERIES: Sizes 24"-168" Available

The K-Flo 47 Series butterfly valve is a large diameter valve line designed for a wide variety of liquid and gaseous applications. With over 50 years of service in the field, the K-Flo 47 series design is fully compliant with AWWA C504 requirements. Series 47 valves are available in flanged connections thru 168", and mechanical joint connections thru 48".

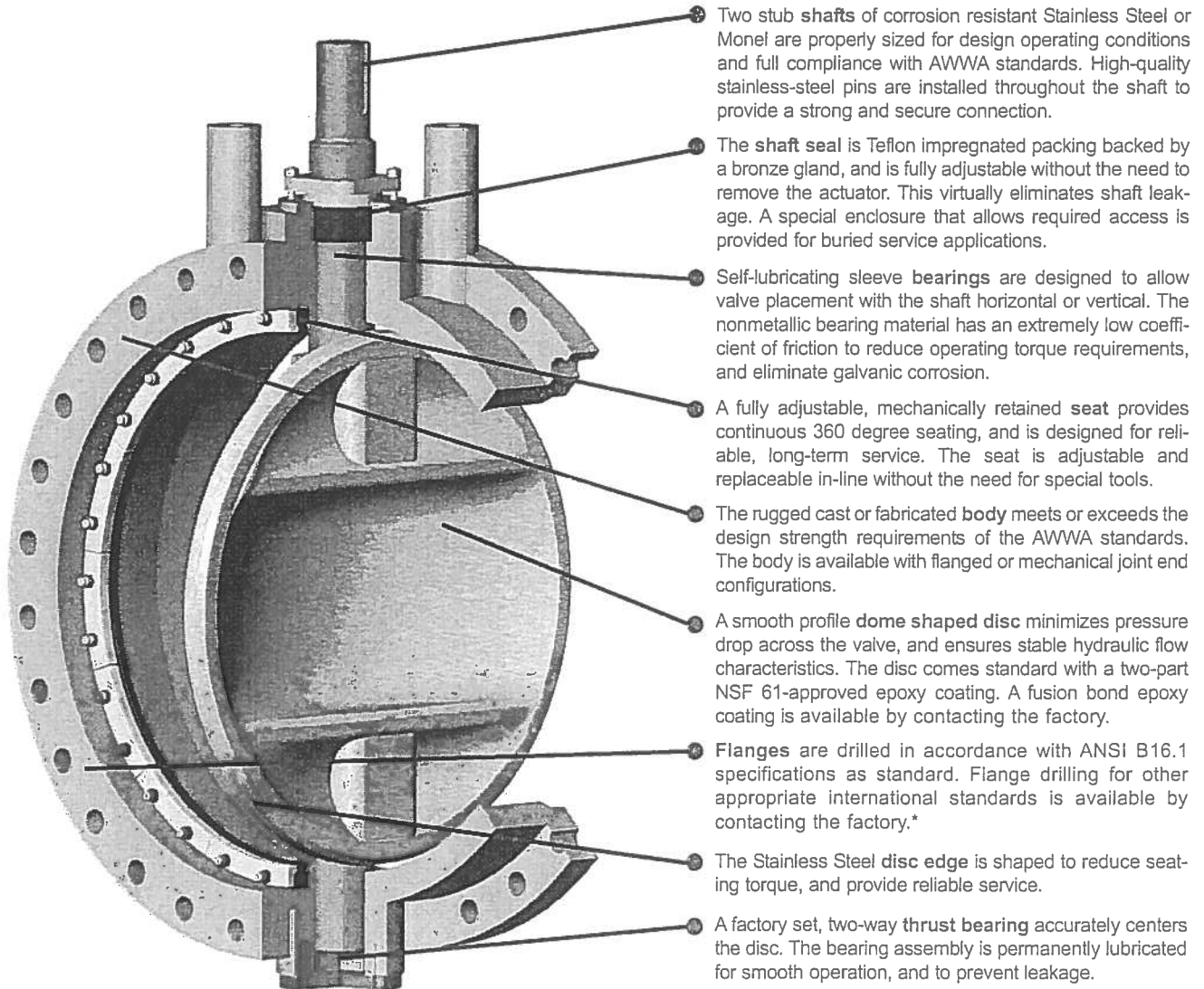

- 1 Two stub shafts of corrosion resistant Stainless Steel or Monel are properly sized for design operating conditions and full compliance with AWWA standards. High-quality stainless-steel pins are installed throughout the shaft to provide a strong and secure connection.
- 2 The shaft seal is Teflon impregnated packing backed by a bronze gland, and is fully adjustable without the need to remove the actuator. This virtually eliminates shaft leakage. A special enclosure that allows required access is provided for buried service applications.
- 3 Self-lubricating sleeve bearings are designed to allow valve placement with the shaft horizontal or vertical. The nonmetallic bearing material has an extremely low coefficient of friction to reduce operating torque requirements, and eliminate galvanic corrosion.
- 4 A fully adjustable, mechanically retained seat provides continuous 360 degree seating, and is designed for reliable, long-term service. The seat is adjustable and replaceable in-line without the need for special tools.
- 5 The rugged cast or fabricated body meets or exceeds the design strength requirements of the AWWA standards. The body is available with flanged or mechanical joint end configurations.
- 6 A smooth profile dome shaped disc minimizes pressure drop across the valve, and ensures stable hydraulic flow characteristics. The disc comes standard with a two-part NSF 61-approved epoxy coating. A fusion bond epoxy coating is available by contacting the factory.
- 7 Flanges are drilled in accordance with ANSI B16.1 specifications as standard. Flange drilling for other appropriate international standards is available by contacting the factory.*
- 8 The Stainless Steel disc edge is shaped to reduce seating torque, and provide reliable service.
- 9 A factory set, two-way thrust bearing accurately centers the disc. The bearing assembly is permanently lubricated for smooth operation, and to prevent leakage.

ITEMS	SIZES	SHAFT
	24"-72" in AWWA Class 75, 150, 250 (meets or exceeds AWWA C504)	ASTM A276, Grade 304 or 316 Stainless Steel.
	Sizes 78" and above are AWWA compliant.	Optional: Monel 17-4pH Stainless Steel on Class 250B
	BODY	DISC
Cast Iron (ASTM A126, Class B)	Ductile Iron (ASTM A536, Grade 65-45-12)	
Ductile Iron (ATM A536, Grade 65-45-12)	w/ 316 Stainless Steel Edge	
SEAT	BEARINGS	
Buna-N; EPDM Optional	316 Stainless Steel; TFE Lined	
	* Class 250B valves with AWWA Type "E" and "F" flanges are available. Please contact the factory.	

- Series 47 valves fully comply w/ AWWA C504's latest edition.
- Series 47 valves have passed the proof of design tests of AWWA C504
- Consult factory for 75B shaft diameters.
- "Q" Dimension is the minimum allowable inside diameter at the centered body face to protect the disc sealing edge from damage when opening the valve.
- Consult factory for valve dimensions in sizes greater than 72" and mech. joint dims.

47 SERIES: Dimensional Data

K-FLO Model 47 (Flanged x Flanged, AWWA Class 150B)

Size in.	A	B in.	C in.	D in.	E	F	G	H	J in.	K in.	L in.	M in.	N in.	P in.	Q in.	Weight in lbs.
24	36	32	18 ¹ / ₂	29 ¹ / ₂	2 ¹ / ₈	8	7 ³ / ₈	3 ¹ / ₂	3	2 ³ / ₄	7 ¹ / ₁₆ X ⁵ / ₈ X2 ¹ / ₂	7 ¹ / ₂	3 ³ / ₄ -10 _{NC} X1 ¹ / ₄ DP	(4)1- ¹ / ₄ -7 _{NC}	(16)1 ³ / ₈	740
30	46 ⁷ / ₈	38 ³ / ₄	25 ⁵ / ₈	36	2 ¹ / ₈	12	8 ³ / ₈	4 ¹ / ₂	3 ⁵ / ₈	3	1 ¹ / ₂ X ³ / ₄ X3 ¹ / ₂	11 ³ / ₄	1-8 _{NC} X1 ¹ / ₂ DP	(6)1- ¹ / ₄ -7 _{NC}	(22)1 ³ / ₈	1650
36	54	46	28 ³ / ₄	42 ³ / ₄	2 ⁷ / ₁₆	12	11 ³ / ₈	4 ⁷ / ₈	4 ³ / ₈	3 ¹ / ₈	1 ¹ / ₂ X ³ / ₄ X3 ¹ / ₂	11 ³ / ₄	1-8 _{NC} X1 ¹ / ₂ DP	(6)1- ¹ / ₂ -6 _{NC}	(26)1 ⁵ / ₈	2380
42	58 ⁷ / ₈	53	30 ¹⁵ / ₁₆	49 ¹ / ₂	2 ¹¹ / ₁₆	12	13 ¹³ / ₁₆	6 ⁵ / ₁₆	5	4	3 ¹ / ₄ X1X5	11 ³ / ₄	1-8 _{NC} X1 ¹ / ₂ DP	(6)1- ¹ / ₂ -6 _{NC}	(30)1 ⁵ / ₈	3260
48	65 ¹⁵ / ₁₆	59 ¹ / ₂	34 ³ / ₄	56	2 ³ / ₄	15	15 ⁷ / ₁₆	6 ⁵ / ₁₆	5 ⁵ / ₈	4	3 ¹ / ₄ X1X5	16	1 ¹ / ₈ -7 _{NC} X2DP	(8)1- ¹ / ₂ -6 _{NC}	(36)1 ⁵ / ₈	4490
54	75 ¹¹ / ₁₆	66 ¹ / ₄	40 ³ / ₁₆	62 ³ / ₄	3	15	18 ³ / ₈	6 ¹⁵ / ₁₆	6 ³ / ₄	5 ¹ / ₂	7 ¹ / ₈ X1 ¹ / ₄ X5 ³ / ₄	16	1 ¹ / ₈ -7 _{NC} X2DP	(8)1- ³ / ₄ -5 _{NC}	(36)2	5970
60	82 ³ / ₄	73	43 ⁵ / ₁₆	69 ¹ / ₄	3 ³ / ₁₆	15	21 ¹ / ₁₆	6 ¹⁵ / ₁₆	7 ¹ / ₄	5 ¹ / ₂	7 ¹ / ₈ X1 ¹ / ₄ X5 ³ / ₄	16	1 ¹ / ₈ -7 _{NC} X2DP	(8)1- ³ / ₄ -5 _{NC}	(44)2	7550
66	89 ⁷ / ₈	80	47	76	3 ³ / ₈	18	23 ³ / ₁₆	8	7 ³ / ₄	6	1X1 ¹ / ₂ X7	18 ³ / ₈	1 ¹ / ₄ -7 _{NC} X2 ¹ / ₄ DP	(8)1- ³ / ₄ -5 _{NC}	(44)2	9920
72	97 ¹ / ₁₆	86 ¹ / ₂	51 ¹ / ₁₆	82 ¹ / ₂	3 ⁹ / ₁₆	18	25 ¹³ / ₁₆	8 ³ / ₁₆	8 ¹ / ₂	6	1X1 ¹ / ₂ X6	18 ³ / ₈	1 ¹ / ₄ -7 _{NC} X2 ¹ / ₄ DP	(10)1- ³ / ₄ -5 _{NC}	(50)2	12,050
78	101 ¹ / ₁₆	93	52 ¹³ / ₁₆	89	3 ³ / ₄	18	29	10 ⁷ / ₁₆	7 ¹ / ₄	7 ¹ / ₄	1 ¹ / ₂ X1 ³ / ₄ X9	18 ³ / ₈	1 ¹ / ₄ -7 _{NC} X2 ¹ / ₄ DP	(10)2-4- ¹ / ₂ _{NC}	(54)2 ¹ / ₄	12,200
84	108 ³ / ₈	99 ³ / ₄	56 ⁷ / ₁₆	95 ¹ / ₂	3 ¹⁵ / ₁₆	18	32	9 ⁷ / ₁₆	7 ³ / ₄	7 ¹ / ₄	1 ¹ / ₂ X1 ³ / ₄ X8	18 ³ / ₈	1 ¹ / ₄ -7 _{NC} X2 ¹ / ₄ DP	(8)2-4- ¹ / ₂ _{NC}	(56)2 ¹ / ₄	16,700
90	116 ³ / ₁₆	106 ¹ / ₂	60 ⁷ / ₁₆	102	4 ³ / ₁₆	21	33 ¹⁵ / ₁₆	10 ³ / ₁₆	8 ¹ / ₂	7 ¹ / ₂	1 ¹ / ₂ X1 ³ / ₄ X9	23	1 ¹ / ₂ -6 _{NC} X2 ¹ / ₂ DP	(20)2- ¹ / ₄ -4- ¹ / ₂ _{NC}	(48)2 ¹ / ₂	22,250
96	122 ⁵ / ₈	113 ¹ / ₄	63 ⁵ / ₈	108 ¹ / ₂	4 ¹ / ₄	21	36 ³ / ₈	12 ¹ / ₄	9	9	1 ¹ / ₂ X2X10	23	1 ¹ / ₂ -6 _{NC} X2 ¹ / ₂ DP	(24)2- ¹ / ₄ -4- ¹ / ₂ _{NC}	(44)2 ¹ / ₂	26,000

K-FLO Model 47 (Flanged x Flanged, AWWA Class 250B)

Size in.	A	B in.	C in.	D in.	E in.	F in.	G in.	H in.	J in.	K in.	L in.	M in.	N in.	P in.	Q in.	WT. lbs.
24	39 ¹ / ₂	36	20 ¹ / ₈	32	2 ³ / ₄	12	5 ⁷ / ₁₆	3 ¹ / ₂	3	2 ³ / ₄	7 ¹ / ₁₆ X ⁵ / ₈ X2 ¹ / ₂	7 ¹ / ₂	3 ³ / ₄ -10 _{NC} X1 ¹ / ₄ DP	(4)1- ¹ / ₂ -6 _{NC}	(20)1 ⁵ / ₈	990
30	50 ⁷ / ₈	43	27 ¹ / ₄	39 ¹ / ₄	3 ¹ / ₈	12	8 ³ / ₈	5 ¹ / ₂	3 ⁵ / ₈	3 ¹ / ₈	1 ¹ / ₂ X ³ / ₄ X3 ¹ / ₂	11 ³ / ₄	1-8 _{NC} X1 ¹ / ₂ DP	(6)1- ³ / ₄ -5 _{NC}	(22)2	1950
36	57 ¹⁵ / ₁₆	50	30 ⁵ / ₈	46	3 ³ / ₈	15	9 ⁷ / ₈	6 ⁷ / ₈	4 ³ / ₈	4	1 ¹ / ₂ X ³ / ₄ X3 ¹ / ₂	16	1 ¹ / ₈ -7 _{NC} X2DP	(6)2-4- ¹ / ₂ _{NC}	(26)2 ¹ / ₄	3000
42	62 ¹¹ / ₁₆	57	32 ³ / ₄	52 ³ / ₄	3 ¹¹ / ₁₆	15	12 ³ / ₈	7 ¹ / ₂	5	5	3 ¹ / ₄ X1 ¹ / ₄ X5	16	1 ¹ / ₈ -7 _{NC} X2DP	(8)2-4- ¹ / ₂ _{NC}	(28)2 ¹ / ₄	4175
48	70 ³ / ₄	65	36 ³ / ₄	60 ³ / ₄	4 ¹ / ₁₆	15	15 ⁷ / ₁₆	8	5 ⁵ / ₈	5 ¹ / ₂	7 ¹ / ₈ X1 ¹ / ₄ X6	16	1 ¹ / ₈ -7 _{NC} X2DP	(8)2-4- ¹ / ₂ _{NC}	(32)2 ¹ / ₄	5475

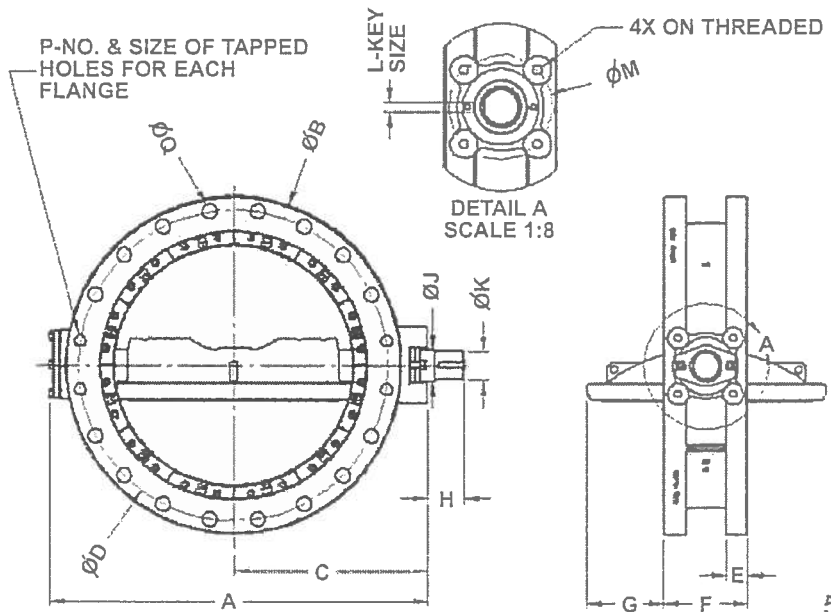
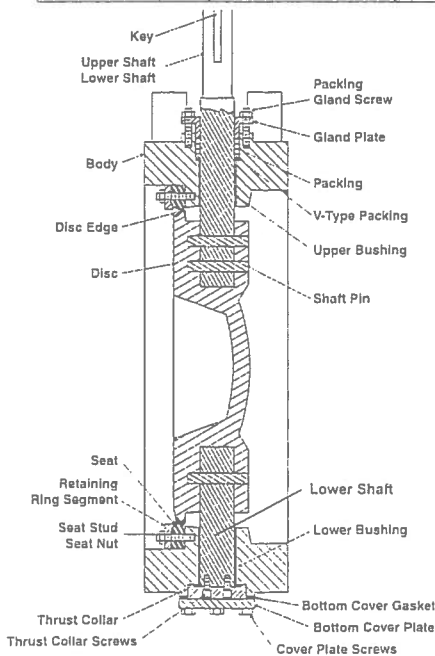

CV VALUES

What is Cv and Why is it Important?

The flow characteristic of a given valve is defined by the valve's Cv value. Cv is defined as the maximum flow (expressed in gallons per minute, or gpm) of water at 60 degrees F, which produces a 1 psig pressure drop across the valve.

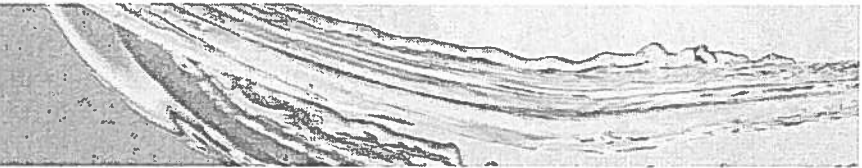

Mathematical Formula for Cv

The mathematical formula for Cv (flow coefficient) is:

$$Cv = Q/\sqrt{\Delta P}$$

Where: Q = Flow rate in gpm;
 ΔP = Pressure Drop across the valve in psig.

Cv can also be used for fluids other than water by using the following formula:

$$Cv = Q/\sqrt{(\Delta P/G)}$$

Where G = Specific gravity of the fluid (water=1.0)
 ΔP = Pressure Drop across the valve in psig.

For example, if the valve must pass water at a flow rate of 300gpm, and the maximum allowable pressure drop is 3psig, the Cv of the valve must be equal to or greater than 173.2.

$$Cv = 300\text{gpm}/\sqrt{3\text{psig}} = 173.2$$

Cv VALUES

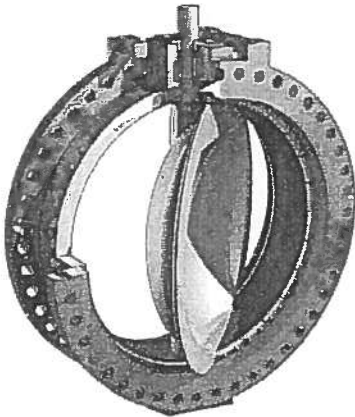

MODEL 47

SIZE	Cv (gpm/ $\sqrt{\text{psi}}$)
24"	27889
30"	42200
36"	62060
42"	78930
48"	107930
54"	131350
60"	169220
66"	212430
72"	255880

Cv VALUES: MODEL 504

SIZE	Cv (gpm/ $\sqrt{\text{psi}}$)
3"	228
4"	463
6"	1069
8"	2372
10"	4380
12"	6515
14"	9574
16"	13356
18"	16898
20"	20421

TNA TRAVELING NUT ACTUATOR

K-Flo provides its 20" and smaller 500 series AWWA Butterfly Valves with the TNA series Traveling Nut Actuator as the standard manual operator. The TNA is designed to exceed the rigorous requirements of AWWA specifications. Unlike other market options like small-sized worm gears, the TNA offers rugged construction and clear design benefits. One key benefit is the variable torque curve generated through the operation stroke. Differing from a worm gear's constant torque production, the TNA traveling nut operator allows the valve to open and close at slower speeds, reducing the potential for line surge from faster valve operation.

The TNA also has many other helpful features including four standard 90-degree key locations to choose from when connecting the operator to the valve. This provides orientation flexibility should the need arise to re-position the actuator due to space confinements.

Available in both Above-Ground (with integral position indicator) and Buried Service configurations.

HOUSING/COVER
Cast Iron ASTM A126

STEM (INPUT SHAFT)
4140 Steel ASTM 434

YOKE
Ductile Iron ASTM A536

CROSSHEAD
4140 Steel, ASTM 434

KEY
4140 Steel, ASTM 434

SQUARE NUT (STOP)
4140 Steel ASTM 434

GUIDE RAIL
4140 Steel ASTM 434

SHAFT COLLAR
4140 Steel ASTM 434

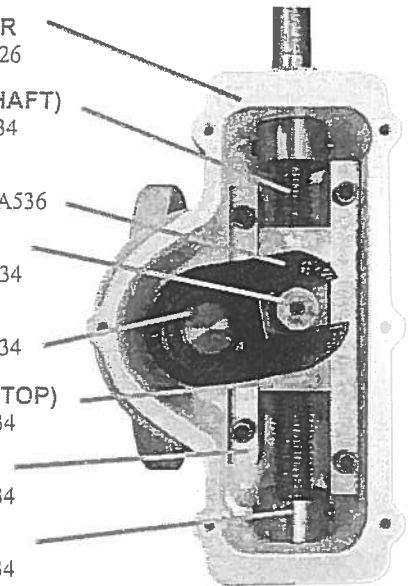

TNA ACTUATOR CHARACTERISTICS

As a butterfly valve disc approaches the closed position, the inherent design characteristics of the traveling nut type actuator cause the disc travel to slow down in relation to the turning of the operating nut or handwheel. This characteristic helps reduce the effects of water hammer caused by sudden valve closure.

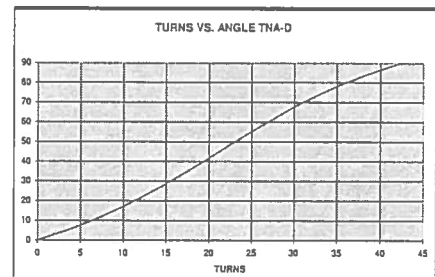
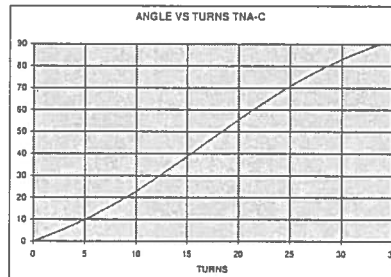
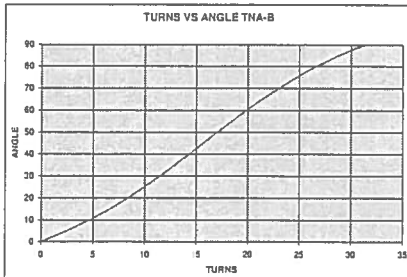

ADDITIONAL ACTUATOR OPTIONS AND EXTENSIONS

K-Flo works with all major actuator manufacturers, and we are capable of mounting any actuators--manual, electric or pneumatic--that our customers may specify. We've listed some of the more traditional actuator options below, and invite you to call us at our factory with any additional requests or questions that you may have.

MANUAL ACTUATION OPTIONS

Above Ground Manual Operators

- Lever operators with ten position selector plate. Available for valve sizes 3" thru 8".

- Handwheel and chainwheel gear operators for all valve sizes. These operators come standard with dial position indicators.

Buried and Submerged Service Gear Operators

- Buried and submerged gear operators are available for all valve sizes. These operators come standard with a 2" AWWA nut and sealed gear housing.

For gears continuously submerged at depths greater than 10 feet, please indicate specifications. This will assure the end user that a gear for the intended service is provided.

POWER OPERATORS

Cylinder Operators

- Cylinder operators are available in pneumatic or hydraulic options. They are available as double acting operators or spring return for a specific failure mode (fail open or fail close). All cylinder accessories are available for on/off or modulating service.

Electric Motor Operators

- Electric motor operators are available in numerous configurations for varied service conditions. Control options for on/off service and modulating service are available.

SUGGESTED K-FLO SPECIFICATIONS

1.00 GENERAL

1.01 WORK INCLUDED

- Furnish labor, materials, equipment and incidentals necessary to install butterfly valves.

1.02 QUALITY ASSURANCE

A. ACCEPTABLE MANUFACTURERS

- Crispin-Kflo (Series 500 for 3" to 20" and Series 47 for 24" and larger)
- Engineer pre-approved equal

B. EXPERIENCE REQUIREMENTS

The Manufacturer shall have had a successful experience in manufacturing tight closing Buna-N or other acceptable synthetic rubber-seated butterfly valves for this type service in the size indicated. The Manufacturer shall have at least 10 years experience in the manufacture of valves. All butterfly valves of the same type shall be the product of one Manufacturer. All materials used shall be new, of high grade, and with properties best suited to the working environment.

C. MANUFACTURER'S REPRESENTATIVE FOR STARTUP AND TESTING

The Valve Vendor or Manufacturer shall provide the services of a competent Manufacturer's representative for a sufficient period of time as required to insure proper adjustment, installation, and operation of the valve.

1.03 SUBMITTALS

A. Certificate of Compliance or complete list of all deviation from the drawings and specifications.

B. Submit installation and assembly drawings complete with seat installation details, showing the manufacturer's dimensions, weights, and loadings.

C. Submit any and all electrical schematic, wiring diagrams, and interconnection diagrams showing wiring, controls, interlocks, and terminals. Label each terminal and wire showing which control or electrical power wire connects to which terminal. Submit manufacturer's catalog data for electrical equipment and enclosures.

D. Submit flow coefficient, Cv, and maximum pressure drop at rated flow rate for each valve size used.

E. Submit manufacturer's installation instructions and certification.

F. Provide O&M manual and spare parts list with descriptive literature, including a cross-section view of valve and all operators, which indicate materials of construction, weights, principal dimensions and other important details.

2.00 PRODUCTS

2.01 BUTTERFLY VALVES

A. All butterfly valves shall be of the tight-closing, rubber-seated type, conforming to the design standards of ANSI/AWWA C504 latest revision, except where noted herein. Valves shall be bubble-tight at the rated pressure in either direction and shall be suitable for throttling service and/or operation after long periods of inactivity. Maximum operating non-shock shut-off pressure and maximum operating non-shock line pressure is 150 psi. Each valve shall be performance and leak tested as specified in AWWA C504 revised as follows: In addition to the testing requirements of AWWA C504, each butterfly valve shall be thoroughly cleaned and opened at least three (3) times prior to testing.

B. All items shall have the name or symbol of the maker, the nominal size, date of manufacture, and the working pressure for which they are designed, cast, stamped, or permanently marked on the body.

C. Butterfly valves shall be Class 150B, unless otherwise indicated and of the flanged short body design. The valve bodies shall be constructed of cast iron ASTM A-126, Class B or ductile iron in accordance with ASTM A-536 with ANSI B16.1 flange drilling or for mechanical joint ends shall conform to ANSI/AWWA C111/A21.11 standard. Flanges shall conform to AWWA Class D standards.

D. Discs for valve sizes 3" - 20" shall be of the concentric design. Valve discs shall be constructed of 316 stainless steel for sizes 3" to 8" and epoxy coated ductile iron ASTM A-536 for sizes 10" to 20". Discs for valve sizes 24" and larger shall be of the offset design to provide a full 360 degree seating surface and shall be constructed from epoxy coated ductile iron ASTM A-536. Valve disc shall have a 316 stainless steel seating edge. Valve disc shall seat at 90 degrees to the access of the pipe and shall require no torque to hold it in the closed position.

E. Valves 3" - 20" shall have a one piece through shaft constructed of stainless steel ASTM A-276, grade 304, corresponding to the requirements of AWWA C504, latest revision. The shaft shall be fastened to the disc by means of a threaded disc pin providing a positive leak proof connection of the shaft to the disc. Valves 24" and larger shall have stub shafts of stainless steel ASTM A-276, grade 304, corresponding to the design requirements of AWWA C504, latest revision. The shafts shall be fastened to the disc by straight pins that provide a .005 interference fit. The use of taper pins for the shaft/disc connection is not acceptable.

F. The resilient seat shall be Buna-N for valves 3" - 20" and shall be simultaneously bonded and vulcanized to body of the valve. All interior surfaces

in contact with water, excluding stainless steel and disc, shall be completely rubber lined. Seats for valves 3"-20" shall be designed so that they will require no internal adjustment or maintenance to seat against a pressure differential of 150 psi on either side of the valve. The resilient seat shall be Buna-N for valves 24" and larger and shall be mechanically retained in the body by means of 316 stainless steel attachment hardware. The seat shall be fully adjustable and replaceable in the field with the use of a standard wrench. No special tools shall be required. Valve seat designs in the body that require the use of epoxy to retain the seat or fillers to increase seat compression are not considered mechanically retained, field replaceable, or adjustable, and will not be accepted. Valves with seat designs that are located on the disc will not be acceptable.

G. All bearings shall be of the self-lubricating, corrosion-resistant, sleeve type. Bearings shall be designed for horizontal and/or vertical shaft loading. The valve assembly shall be furnished with a factory set two-way thrust bearing designed to center the valve disc in the valve seat at all times.

H. Shaft packing shall be of the V-type, self-adjusting type and suitable for pressure and vacuum service. Valves 24" and larger shall be designed with pull down packing which shall be fully adjustable and replaceable without removing the actuator. The packing shall be PTFE, interlocking braid, self compensating type. Stuffing boxes for pull down packing shall have a depth sufficient to accept at least four (4) rings of self-compensating type packing specifically selected for the operating pressure to be encountered.

I. The Manufacturer shall certify that the butterfly valves are capable of operating in continuous duty service under the specified pressures and flow conditions.

J. The interior of valves 3" - 20" shall be completely rubber lined. The valve disc shall either be entirely 316 stainless steel or be ductile iron with epoxy coating from an AWWA NSF-61 coating system. The use of liquid epoxy on body interior surfaces shall not be allowed. Valves 24" and larger: the interior of the valve body and the exterior of the valve disc shall be cleaned and sandblasted and lining shall be applied as per the Manufacturer's instructions. The lining material shall be in compliance with ANSI/NSF Standard 61, for contact with potable water. The lining material shall be "Pota -Pox" as manufactured by Tnemec, or equal. The interior lining shall be applied in a minimum of two coats, at 4-5 mils per coat; the total dry thickness shall be 8 - 10 mils.

K. The exterior surfaces shall be cleaned and sandblasted and coating shall be applied in accordance with the Manufacturer's instructions. Surface face cleanliness shall be inspected and any contaminants on the surface shall be removed prior to the coating operations. The coating material shall be "Pota -Pox" as manufactured by Tnemec, or equal. The coating material shall be applied in a minimum of two coats, at 4-5 mils per coat; the total dry thickness shall be 8- 10 mils.

3.00 EXECUTION

3.01 INSTALLATION

A. Valve installation shall be in strict accordance with the Manufacturer's printed recommendations, and the Contract Documents. Valve shaft shall be truly vertical or horizontal as indicated.

B. Four (4) copies of Final Operations and Maintenance Manuals are to be provided. The manuals shall include but not be limited to the following: installations and adjustment instructions; maintenance procedures and operation parameters; wiring diagrams; control diagrams; control sequence and instructions; lubrication schedule, including type, grade, temperature range, and frequency; diagrams and illustrations; test procedures, performance data; and parts list.

3.02 FIELD QUALITY CONTROL

A. Upon completion of installation of the butterfly valves an acceptance test shall be conducted to verify the satisfactory operation of the valves. The valves must perform in a manner acceptable to the Engineer before final acceptance will be made by the owner.

3.03 WARRANTY

A. The manufacturer warrants the workmanship and materials to be free from defect for a period of one (1) year from the date of shipment from the factory. The manufacturer shall replace any parts deemed defective during the said time period, provided that the product has been properly applied and used for the purpose intended. The manufacturer must be notified of the alleged defect and provided with the proper data as to the application. The manufacturer at its discretion will repair or replace the product, F.O.B. factory. The manufacturer shall not be liable to the buyer or others for any consequential or incidental damage. The unit shall not be disassembled in any way by the buyer, unless written permission and instruction is provided by the manufacturer—otherwise the warranty is void. The buyer agrees that the manufacturer shall not be liable for any loss, cost, expenses, or damages from the product, its uses, installation or replacement, instructions, labeling, technical data, description of the product, its uses or warnings or lack of any of the foregoing. No other warranties, written or oral, expressed or implied, shall apply.