

A1 SIZE - 594mm x 841mm

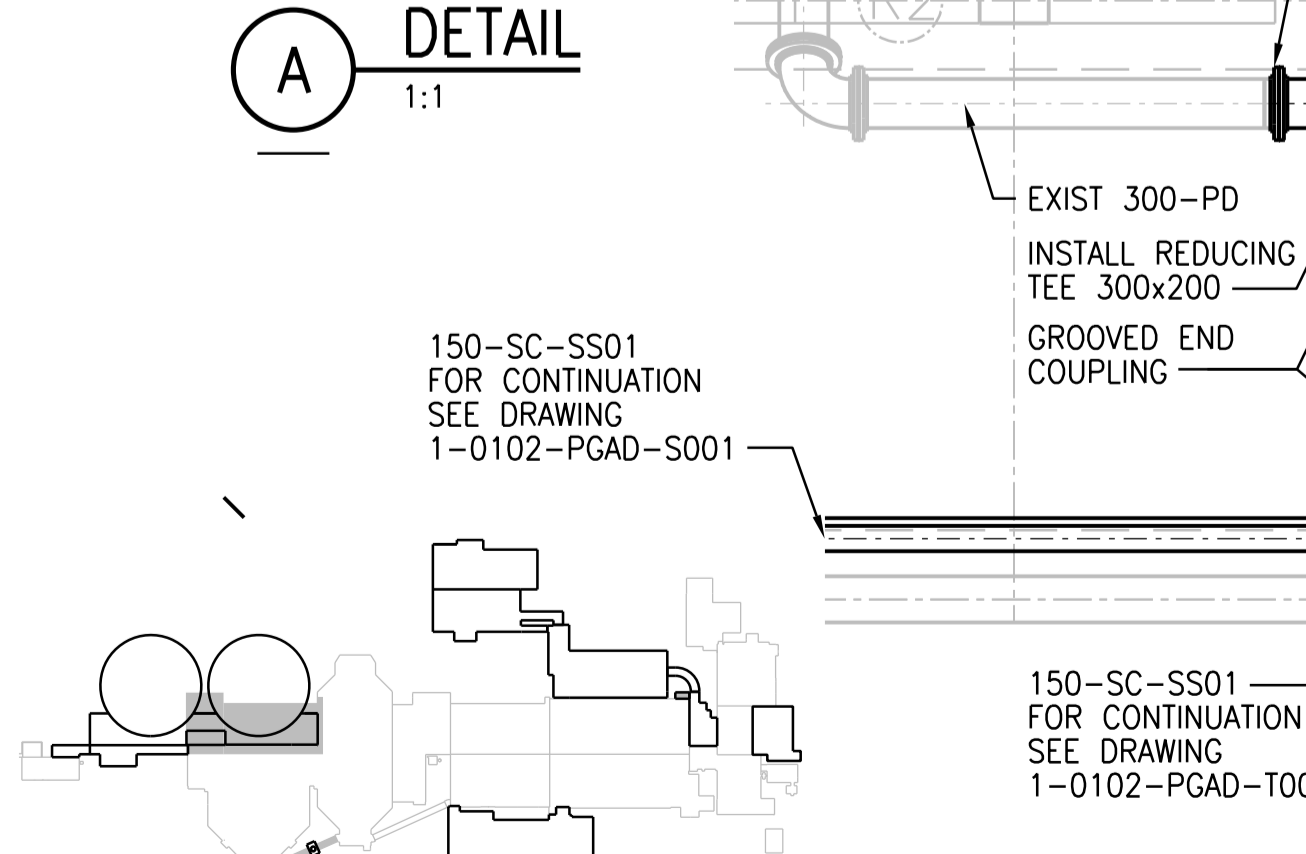
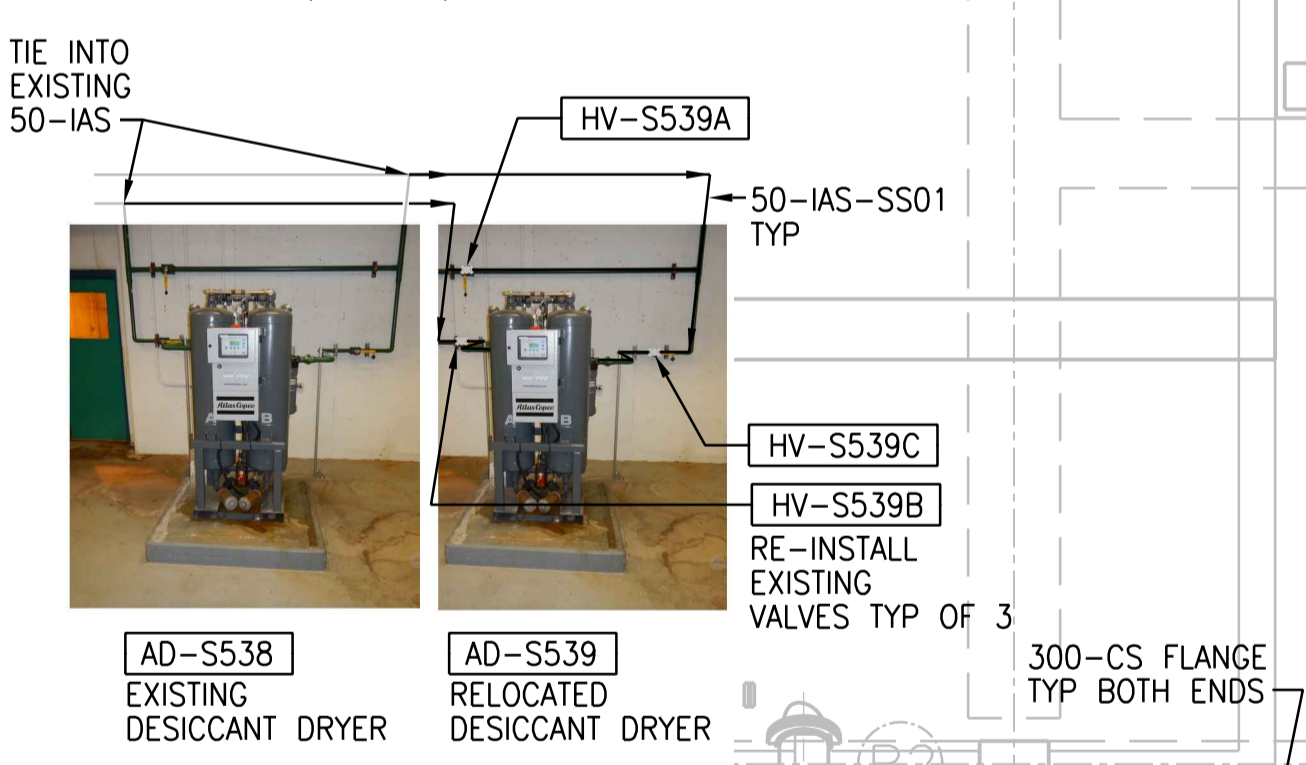
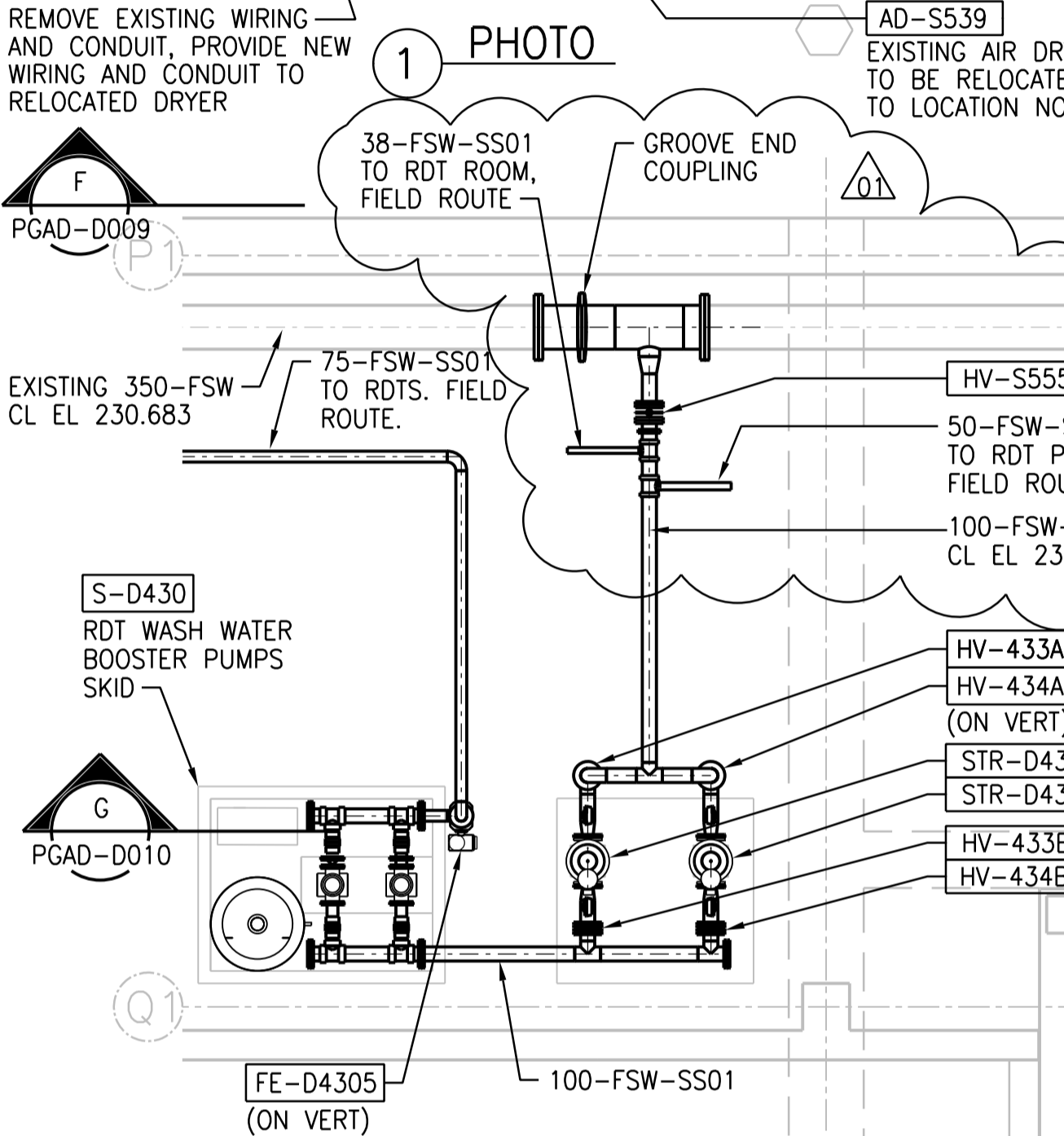
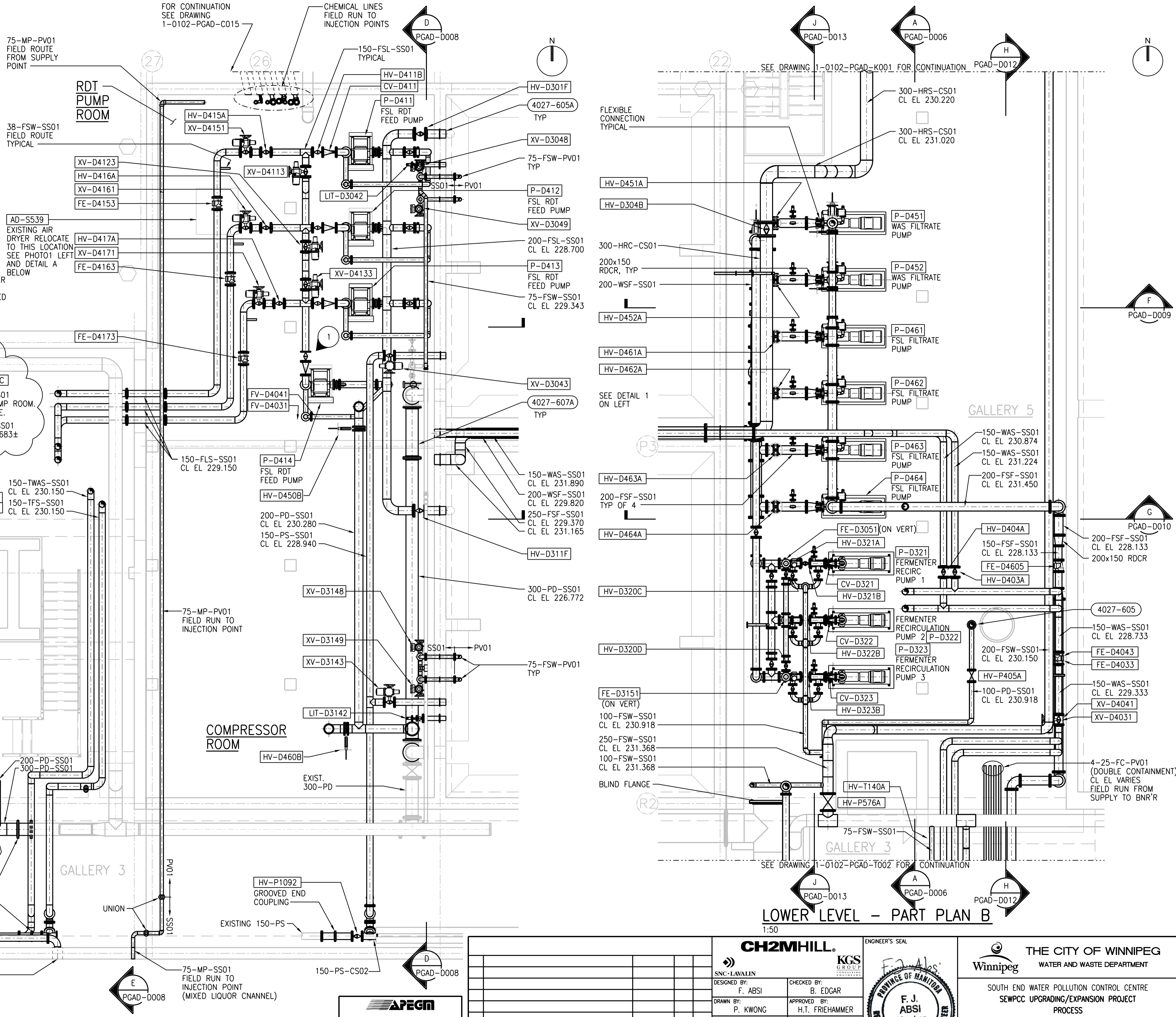

LOWER LEVEL - PART PLAN A
1:50

LOWER LEVEL - PART PLAN B
1:50

APEGM
Certificate of Authorization
CH2M HILL Canada Ltd.
No. 1441

NO.	REVISIONS	DATE	DESIGN	CHECK
01	ISSUED FOR ADDENDUM 4 - 976-2016	2017/06/30	B.C.	J.C.
00	ISSUED FOR CONSTRUCTION - 976-2016	2017/04/05	B.C.	J.C.

CH2MHILL
SNC-LAVALIN
DESIGNED BY: F. ABSI
DRAWN BY: P. KWONG
SCALE: 1:100
DATE: 2017/04/05
CONSULTANT NO.: 474248

ENGINEER'S SEAL
F. J. ABSI
Member
36875
REGISTERED PROFESSIONAL ENGINEER

THE CITY OF WINNIPEG
WATER AND WASTE DEPARTMENT
SOUTH END WATER POLLUTION CONTROL CENTRE
SEWPPC UPGRADING/EXPANSION PROJECT
PROCESS
FERMENTERS/THICKENERS
LOWER LEVEL - PART PLANS
CITY DRAWING NUMBER: 1-0102-PGAD-D004
SHEET: 001
REV: 01
SIZE: A1

©CH2M HILL 2017. ALL RIGHTS RESERVED.