

3 South Elevation
Scale: 1/8" = 1'-0"

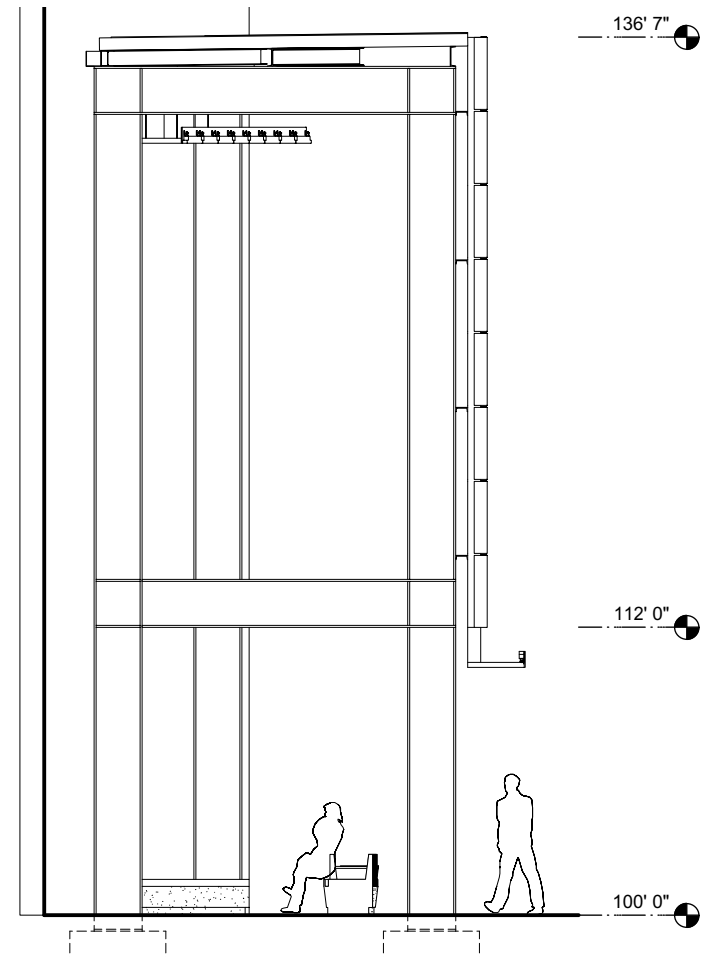

4 North elevation
Scale: 1/8" = 1'-0"

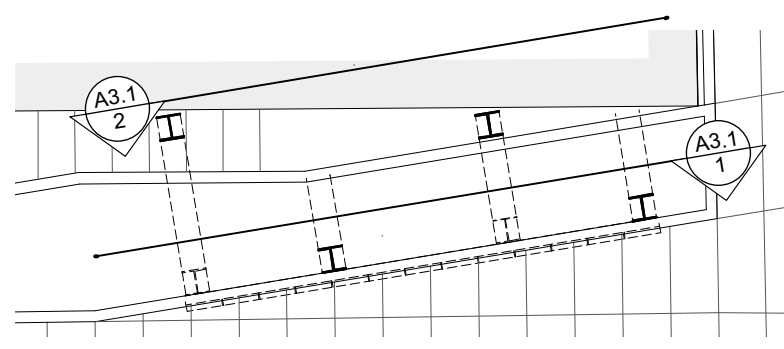

5 Key plan
Scale: 1/16" = 1'-0"

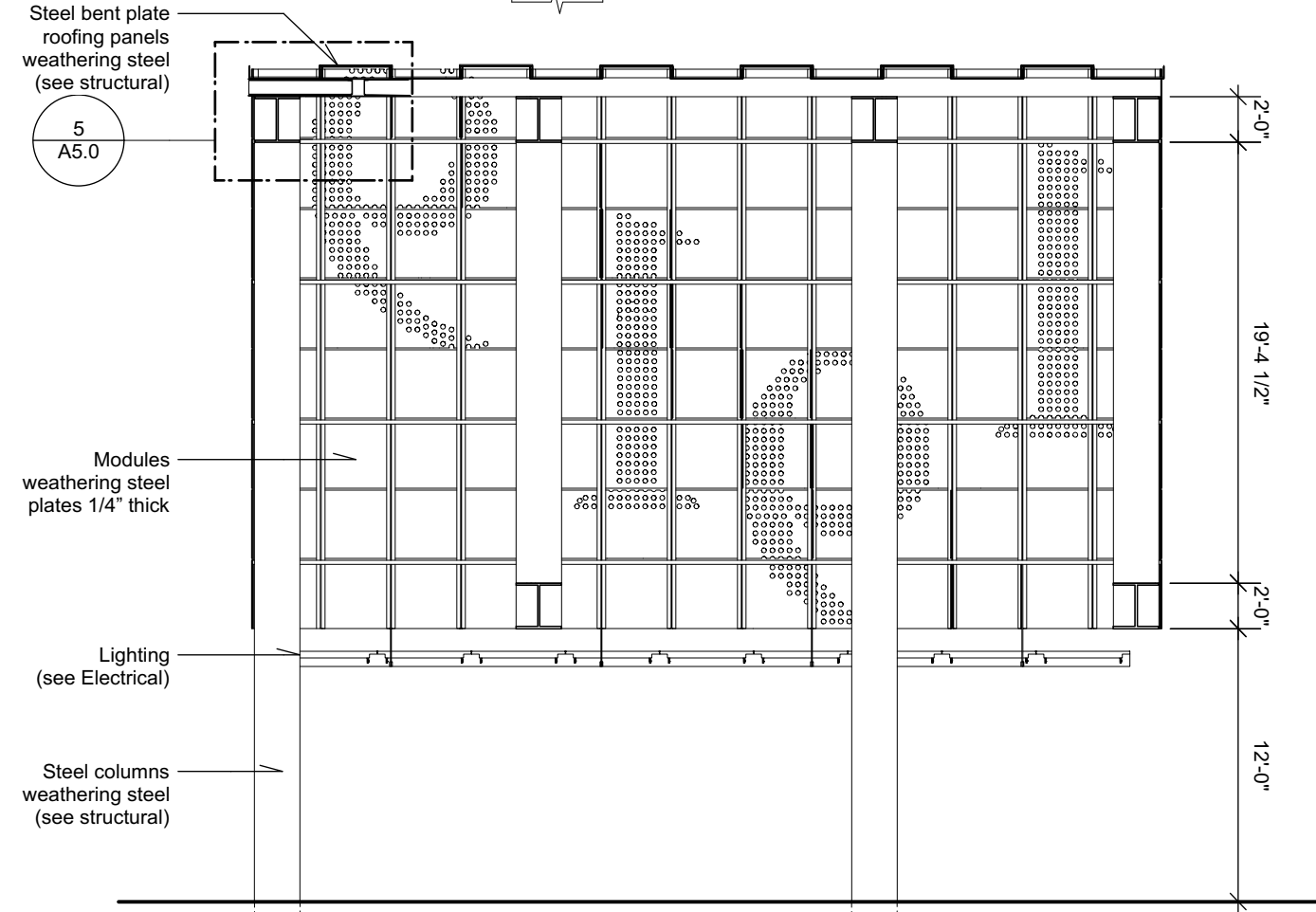

1 Section
Scale: 1/8" = 1'-0"

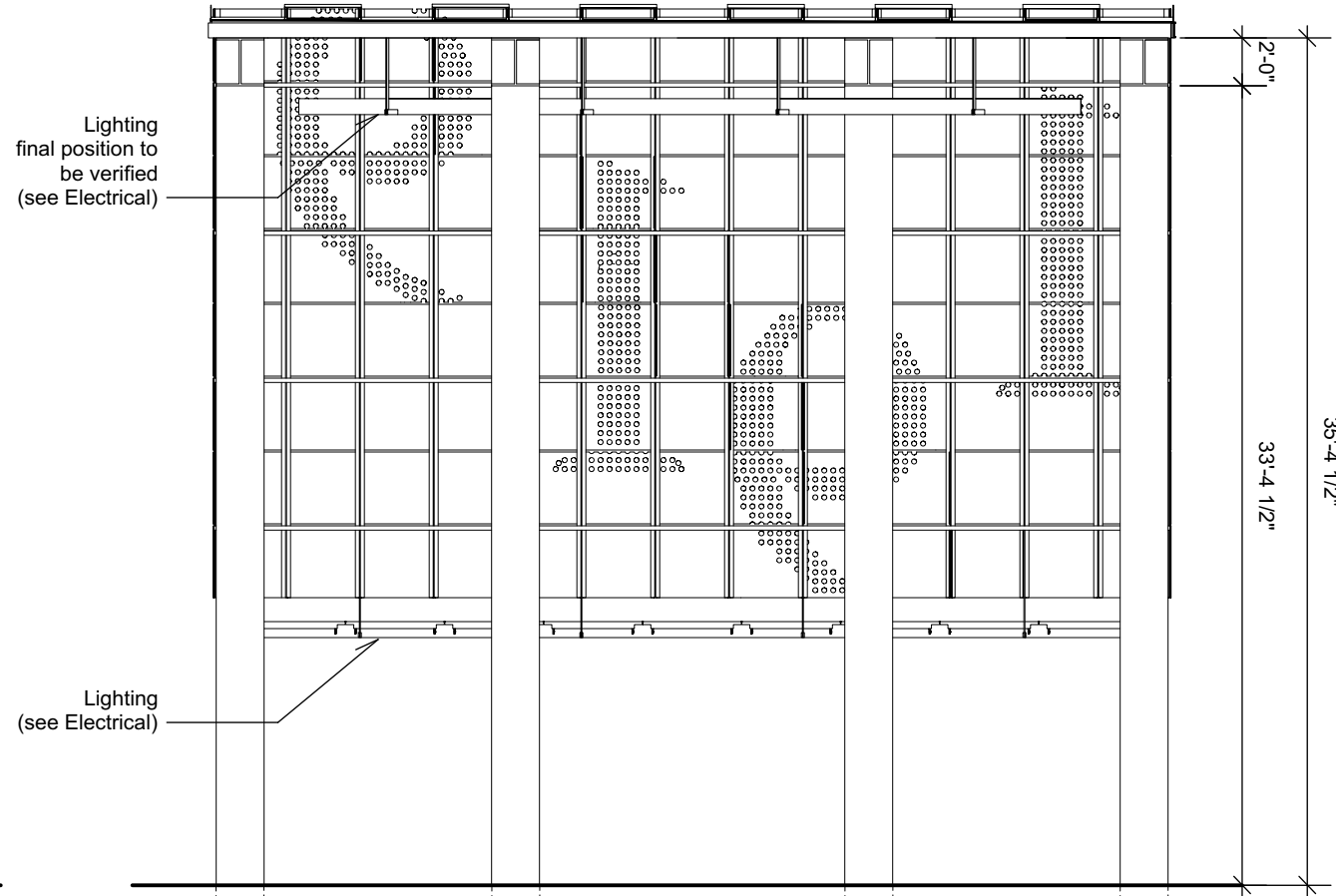

2 Section
Scale: 1/8" = 1'-0"

Interp. Panel Adjustment 2017/01/27
ISSUED FOR CONSTRUCTION 2016/11/28
ISSUED FOR PRICING 2016/10/20

1602	2016/11/28
------	------------

PROVINCE OF MANITOBA
THOMAS MONTEYNE
REGISTERED ARCHITECT

PROVINCE OF MANITOBA
MONTEYNE ARCHITECTURE WORKS INCORPORATED
REGISTERED ARCHITECTURAL FIRM

MONTEYNE
architecture works
INCORPORATED

1919 MARQUEE
Winnipeg, Manitoba
Intersection Lily St & Market Ave

ELEVATIONS MONUMENT