

Part 1 General

1.1 SUMMARY

- .1 Specification covers the design criteria and application requirements for piping insulation systems.

1.2 REFERENCES

- .1 American Society for Testing and Materials (ASTM)
 - .1 ASTM A167, Stainless and Heat Resisting Chromium Nickel Steel Plate, Sheet and Strip
 - .2 ASTM A480, Flat-Rolled Stainless and Heat Resisting Steel Plate, Sheet and Strip
 - .3 ASTM A580, Stainless and Heat Resisting Steel Wire
 - .4 ASTM B209, Aluminum-Alloy Sheet and Plate
 - .5 ASTM C165, Method for Measuring Compressive Properties of Thermal Insulation's
 - .6 ASTM C168, Standard Definitions of Terms Relating to Thermal Insulating Materials
 - .7 ASTM C177, Thermal Conductivity of Materials by Means of the Guarded Hot Plate
 - .8 ASTM C193, Magnesia Thermal Insulating Cement
 - .9 ASTM C411, Hot-Surface Performance of High Temperature Thermal Insulation
 - .10 ASTM C449, Mineral Fibre Hydraulic-Setting Thermal Insulating and Finishing Cement
 - .11 ASTM C450, Prefabrication and Field Fabrication of Thermal Insulating Fitting Covers for NPS Piping, Vessel Lagging and Dished Head Segments
 - .12 ASTM C533, Calcium Silicate Block and Pipe Thermal Insulation
 - .13 ASTM C547, Mineral Fibre Preformed Pipe Insulation
 - .14 ASTM C550, Test for Trueness and Squareness of Block Thermal Insulation
 - .15 ASTM C552, Cellular Glass Block and Pipe Thermal Insulation
 - .16 ASTM C585, Inner and Outer Diameters of Rigid Thermal Insulation for Nominal Sizes of Pipe and Tubing
 - .17 ASTM C592, Mineral Fibre Blanket Insulation and Blanket-Type Pipe Insulation (Metal-Mesh Covered) (Industrial Type)
 - .18 ASTM C612, Mineral Fibre Block and Board Thermal Insulation
 - .19 ASTM C647, Properties and Tests of Mastics and Coatings for Thermal Insulation
 - .20 ASTM C692, Evaluating the Influence of Wicking-Type Thermal Insulations on the Stress Corrosion Cracking Tendency of Austenitic Stainless Steel.
 - .21 ASTM C795, Wicking Type Thermal Insulation for use over Austenitic Stainless Steel
 - .22 ASTM C871, Chemical Analyses of Thermal Insulation Materials for Leachable Chloride, Silicate and Sodium Ions
 - .23 ASTM E84, Surface Burning Characteristics of Building Materials

1.3 DEFINITIONS

- .1 The definitions listed in ASTM C168 shall apply.
- .2 Moisture-Barrier:
 - .1 An inner lining for the aluminum jacket weather-barrier of an insulation installation, which will prevent the alkaline condensate, which normally tends to form on the inner surface of the metal jacket, from contacting the metal jacket.
- .3 Weather-Barrier or Weathercoat:
 - .1 A material or materials, which, when installed on the outer surface of thermal insulation, protects the insulation, protects from rain, snow, sleet, wind, solar radiation, atmospheric contamination, and mechanical damage.
- .4 Weather-Moisture-Barrier:
 - .1 A material which combines the properties of a weather-barrier and a moisture-barrier.
- .5 Sealer:
 - .1 A putty-like substance, composed of various materials, used as a barrier to the passage of water vapour or liquid water into the joint formed by the mating surfaces of jackets and water-and vapour-barriers over insulation. A good sealer will possess relatively little shrinkage. There are several types of sealers, such as nonsetting, setting, and heat resisting.
- .6 Flame Spread:
 - .1 The rate, expressed in distance/time, at which a material will propagate flame on its surface. As this is difficult property to measure in time and distance, the measure is now by flame spread index to enable the comparison of materials by test methods.
- .7 Combustibility:
 - .1 That property of a material which measures its tendency to burn. It is normally expressed in the arbitrary terms of "Flame Spread Index" and "Smoke Density Index", according to ASTM E-84.
- .8 Compressive Strength:
 - .1 That property of a material which enables it to resist any change in dimensions when acted upon by a force tending to squeeze or shorten it. See also ASTM C 165.

1.4 ACTION AND INFORMATIONAL SUBMITTALS

- .1 Submit manufacturer's printed product literature, specifications and datasheet. Include all product specifications, including but not limited to insulation material, cements, mastics, caulking material, jacketing, banding, and fasteners.
- .2 Material storage requirements, including shelf life, storage temperature and any special safety requirements for handling and storing of insulation materials or components.
- .3 Installation details of insulation expansion joints, breather springs.
- .4 Repair procedures for damaged areas of insulation and/or jacketing or weatherproofing.
- .5 Inspection and testing procedures
- .6 Submit copies of Workplace Hazardous Materials Information System (WHMIS) Material Safety Data Sheets (MSDS).

1.5 QUALITY ASSURANCE

- .1 Qualifications:
 - .1 Installer: specialist in performing work of this Section, and have at least 5 years successful experience in this work, qualified to standards and member of TIAC.

1.6 DELIVERY, STORAGE AND HANDLING

- .1 Deliver, store and handle materials in accordance with manufacturer's written instructions.

Part 2 Materials

2.1 GENERAL

- .1 Trade names, as used in Specification, are included solely for the purpose of indicating the quality of material required, and are not intended to exclude equal or better items offered by other Manufacturers. Comparable products may be submitted for approval by the Contract Administrator.
- .2 The recommendations of the insulation vapour barrier manufacturers shall be followed in addition to the requirements of this Section. Where manufacturer's instructions are given in permissive terms, e.g., "should" and "recommended", these shall be considered mandatory.
- .3 Insulation materials and accessories shall be new, undamaged and shall preferably be of domestic origin. Factory or manufacturer's "rejects" or "seconds" will not be acceptable for use under Section.
- .4 Insulation materials, including cements, coverings, shall not contain asbestos.
- .5 No type of insulating material shall crack, sag, delaminate, or show evidence of flaming, glowing, smoldering, or smoking when tested in accordance with ASTM C411 at the temperature on which the insulation requirements are based. In addition, rigid insulation material shall not warp more than 1/4" over a 36" test length.
- .6 All insulating materials, including cements, mastics and adhesives shall have a flame spread classification of not more than 25 per ASTM E84.

2.2 STORAGE AND HANDLING

- .1 General
 - .1 All materials shall be delivered in unopened standard commercial containers, bearing the manufacturer's original label with the following information:
 - .1 Name of Manufacturer.
 - .2 Name of contents.
 - .3 Quantity of contents.
 - .4 Lot or batch number.
 - .5 WHMIS label.
- .2 Storage of Insulation Materials
 - .1 Proper warehousing or other weather protected storage shall be provided for materials and accessory items. Cartons of insulation and accessories shall be stacked in such a manner that cartons in lower levels will not be compressed,

damaging the material within those cartons. Containers shall be stacked in the manner recommended by the manufacturer.

2.3 STORAGE OF METALLIC COMPONENTS

- .1 Aluminum sheets, or coils or other metals, shall be protected from rapid changes of temperature to prevent oxidation or other staining (discoloration) film forming on surface.

2.4 INSULATION MATERIALS FOR AUSTENITIC STAINLESS STEEL

- .1 In cases where the piping to be insulated is constructed of austenitic stainless steel materials, the insulation shall have a chloride content less than 600 ppm.
- .2 Water leaching and chemical tests shall be performed by the seller on three samples from each type of material in contact with the stainless steel piping, in accordance with ASTM C871.
- .3 The leached products shall be tested for stress corrosion cracking (SCC) effects on austenitic stainless steel according to ASTM C692. The Seller shall provide a report of compliance which shows that the samples conform to Section prior to supply of any insulation.
- .4 Acceptance of the insulating materials chemical composition and their effects on SCC of the stainless steel shall be per ASTM C795.

2.5 INSULATION MATERIALS FOR PIPING

- .1 Preformed rigid piping insulation shall be furnished in standard lengths with ends cut square. Dimensions shall conform to ASTM C585. Rigid block insulation shall be furnished true and square in compliance with ASTM C550.
- .2 Insulation for piping shall be sectional, segmental, beveled lag, or scored block.
- .3 Insulation for fittings, flanges and valves may be field fabricated, shop fabricated, or molded. All insulation shall be in compliance with ASTM C450. Insulation thickness shall match the adjacent insulation.
- .4 Materials of insulation for piping shall meet the requirements of the applicable ASTM specification.
 - .1 C533 "Calcium Silicate Block and Pipe Thermal Insulation"
 - .2 C547 "Mineral Fibre Preformed Pipe Insulation."
 - .1 Class 3: For Mineral Wool (6-10 lb/ft³)
 - .2 For service applications above 400°F, mineral wool products with higher nominal densities shall be preferred.
 - .3 Class 2: for Fibrous glass (3-8 lb/ft³)
 - .3 C552 "Cellular Glass Block and Pipe Thermal Insulation"
- .5 The minimum compressive strength of calcium silicate insulation shall be 140 psi to produce 5% compression as per ASTM C165.
- .6 Blanket insulation acceptable product is Thermal Ceramics "Superwool 607". Thermal Ceramics "Kaowool" is acceptable for patching/filling holes.

2.6 THERMAL INSULATING CEMENT

- .1 Thermal Insulating Cement shall meet the requirements of ASTM C449.

2.7 MASTIC SEALER

- .1 Use of Mastics is not acceptable.

2.8 METAL JACKETING

- .1 Aluminum sheet weather jacketing for piping shall be in compliance with ASTM B209. Alloy and temper of aluminum sheet shall be 3003 - H14 or 5005 - H15 with the exception of two piece, die-formed aluminum elbow covers which shall be 1100, dead soft 22 ga thick. Straight aluminum piping jacketing shall be 26 ga thick. Gore sections shall be 24 ga thick.
- .2 Aluminum piping jackets shall have a factory applied epoxy-polyester moisture barrier with a minimum film thickness of .6 mil. The enamel moisture barrier shall face the insulation.
- .3 Stainless steel weather jacketing for piping shall be in compliance with ASTM A480, and shall be supplied in grade 304 (unless otherwise stated) tempered to soft anneal and 2B (dull) finish. The sheet thickness shall be 26 ga. Stainless steel jacketing requires no moisture barrier.

2.9 BANDS, SEALS AND BREATHER SPRINGS

- .1 Banding for piping shall be 24 ga, 300 series stainless steel conforming to ASTM A480, Banding shall have a smooth finish with edges free from burrs. Width of bands for piping shall be 0.5" for lines NPS 2 to NPS 24 inclusive and 0.75" for larger lines. Width of bands for equipment shall be 0.75" or as indicated on the appropriate Standard Drawings.
- .2 Support fittings, such as wing type seals, "S" clips, "J" clips, expansion joints, finger straps, etc., shall be 300 series stainless steel.
- .3 Breather Springs shall be 300 series stainless steel, with tensile strength of 275,571 psi, 4" long.

2.10 CAULKING MATERIAL

- .1 Caulking Material shall be Childers Chil-joint (CP-70) or approved equivalent in accordance with B7. Caulking shall be applied on electric and steam traced lines at the beginning and end of the tracer where passed through insulation. Other caulking shall be applied as per the applicable Standard Drawings.

2.11 TAPES

- .1 Fastening tape shall be a pressure sensitive glass filament tape.
- .2 Aluminum foil tape shall be an adhesive type, 5 mils thick 2" wide with a transparent synthetic adhesive on one side, furnished in rolls.

2.12 TIE AND LACING WIRE

- .1 Wire shall be fully annealed 300 series stainless steel conforming to ASTM A 580, 18 ga for lines up to NPS 6, 16 ga for lines up to NPS 24 and 14 gauge for larger lines.

2.13 FASTENERS

- .1 Screws
 - .1 Screws shall be Stainless steel type 304 or 316 Type A, No. 8 by 0.5" long self tapping with Robertson or hex head. The spacing of screws shall be 6".

- .2 Rivets
 - .1 All blind rivets for aluminum jacketing shall be aluminum with steel mandrels. Rivets for stainless steel jacketing shall be stainless steel with steel mandrels. The spacing of rivets shall be 6".

2.14 ADHESIVES AND SEALERS

- .1 Joint Sealer or Sheet Metal Lap Sealer
 - .1 Joint sealer shall be metallic gray moisture barrier sealant suitable for use with all types of low and dual temperature insulations and remain flexible in service, will not crack or shrink during repeated cycles of high and low temperature. (Benjamin Foster, Foam seal 30-45)
- .2 High Temperature Fabrication Adhesive
 - .1 For calcium silicate insulation with service temperatures up to 700°F, an inorganic adhesive compatible with calcium silicate can be used. The adhesive must be non-flammable in the wet state and totally incombustible in the dry state (Childers CP-97/CP-98, Benjamin Foster 81-27/81-93).
 - .2 For service temperature above 700°F, or with glass or mineral wool insulation, use of adhesives shall not be permitted. Tie wire shall be used to hold the insulation before the application of metal jacketing.

Part 3 Design

3.1 GENERAL

- .1 If insulation thickness required exceeds 3" or the hot face temperature exceeds 600°F, the insulation shall be applied in not less than two layers.
- .2 Items requiring insulation for noise control shall be insulated with fibrous glass or mineral wool with phenolic binder for temperatures up to 392°F and with mineral wool with ceramic binder from 392°F through 1202°F. Insulation thickness requirements for items requiring insulation for process, personnel protection and noise control reasons shall be in accordance with the system requiring the greater thickness. (Fibrous Glass 3-8 lb/ft³; Mineral Wool 5.5-10 lb/ft³).
- .3 Valves and flanges in hydrogen service or toxic service (including hydrogen sulphide, sulphuric acid) shall not be insulated.
- .4 Valves and flanges in steam service shall be insulated.
- .5 Where external flange insulation is specified, it shall be restricted to applications meeting all of the following conditions:
 - .1 Max. Fluid Operating Temp. / Design Pressure: 554°F / 600 psig
 - .1 Steam service flanges shall be insulated for temperatures up to a maximum fluid operating temperature of 752°F and a maximum design pressure of 650 psi (ga).
 - .2 Flange Material : C.S. or Low Alloy Steel: (to 5% Cr)
 - .3 Bolt Material Grade: B7, B16
 - .4 Insulation Details

- .1 Insulation systems around flanged joints shall be provided with a ½" diameter drain tube or vent (tell-tale). For hydrocarbon services, the flange periphery shall, in addition, be fitted with a leak band.
- .2 Metal jacket weatherproofing is required.
- .3 The design shall permit removal of the insulation system without destruction of the insulation on the connective piping.
- .4 Drains and vents shall be piped to a safe location, for operator safety and to prevent direct impingement on adjacent equipment, for the following services:
 - .1 Highly corrosive
 - .2 Flammable and combustible fluids with operating temperatures above their flash points
 - .3 Light hydrocarbons, lighter than 68° API
- .6 Seal pots, vent chambers and drip pots shall be installed outside provided they are not in superheated steam service.
- .7 Inverted bucket type steam traps shall be insulated if installed outside provided they are not in superheated steam service.
- .8 The design of thermal insulation systems, including the selection of paints, adhesives, weather coatings, and joint sealers, shall take into account that piping and equipment may be subject to elevated temperatures during steaming out, cleaning, and flushing operations. Normal operating hot face temperature under 248°F shall be identified by caution signs indicating limitations of the insulation system to elevated temperatures.

3.2 JACKETING

- .1 A weatherproofed insulating cement finish is not an acceptable alternative to a metal jacket.
- .2 Piping at or below grade which is subject to exposure to ground moisture and is insulated with cellular glass insulation shall have an applied coating of an elastomeric material (such as butyl rubber) which shall be reinforced with open weave synthetic fibre fabric 6 x 6 to 10 x 10 mesh.

3.3 INSULATION OF PIPING

- .1 Each line shall be insulated as a single unit.
- .2 Insulation for fittings, flanges, and valves, if required, shall be the same thickness as the insulation on the pipe.
- .3 All traced lines shall be insulated. Valves and flanges shall be insulated as indicated on the drawings.
- .4 Flanges and valves shall be with fixed or removable insulation and jacket in accordance with Standard Details No. PD-6.05, PD-6.06, and PD-6.07. For piping up to 24" NPS, insulation shall be by means of independently removable insulation assemblies, (pre-formed). For sizes greater than 24" NPS, use block insulation, 12" wide by 36" long scored with three v-grooves.
- .5 Insulation that is adjoining to non-insulated flanges shall be beveled back one bolt length to allow easy removal of stud bolts and nuts.
- .6 Insulation on valves shall leave the packing gland accessible, unless otherwise indicated in tracing details.

- .7 Pipe fittings and bends up to NPS 2 shall be insulated by wrapping with ceramic fibre blanket (6 or 8 lb/ft³ density) and jacketing with performed metal covers.
- .8 Fittings larger than NPS 2 shall be insulated with segments of pipe insulation, and voids packed with ceramic fibre. Alternatively, segmented premolded fittings may be used on an economical basis.
- .9 Pipe insulation at piperack module field junction shall be temporarily left off 18" on each side of the weld prior to completion in the field. Butt ends of the insulation shall be protected from the weather.
- .10 Pipe fittings up to NPS 12 shall be weatherproofed with two-piece stamped metal covers. Fittings larger than NPS 12 shall be protected with interlocking gore elbows.
- .11 Tie wires or banding used for piping insulation shall be located on 9" centres. Wires shall be properly tightened, have loose ends cut off and twisted ends bent down flush with the insulation.
- .12 Jacketing shall be overlapped a minimum of 3" and positioned to shed water. To allow for thermal expansion and movement of jacket sections, screws shall not be used in the end laps of jackets.
- .13 Where continuous insulation of piping at support points is specified, and pipe shoes are not specified, the insulation shall be of the load bearing type capable of carrying the piping load.

3.4 ELECTRICALLY TRACED PIPING

- .1 The insulation shall be applied in a manner so that the electrical heating cables do not become embedded in the insulation. Pre-grooved wrap-around insulation shall not be used due to the problem of the heating cable becoming embedded in the grooves and causing cable burnout. Seams in the insulation shall be located as far as possible from the electric tracing cable, to help prevent the cables from becoming embedded in the seam. Extreme care shall be taken during the insulation and weatherproofing, to avoid damage to the heating cable or cold leads.
- .2 Fittings shall not be permitted to be left bare, although this may be inconvenient for maintenance or operations. The only exception shall be due to safety concerns.
- .3 Unless prohibited by 3.1 all flanges shall be completely insulated.
- .4 Insulation on valves shall cover the valve bonnet, unless in services listed in 3.1.
- .5 Additional insulation thickness shall be provided for enclosures on valves/flanges etc. due to the increased heat loss over the larger surface area of the enclosure.

3.5 PIPING INSULATION SCHEDULE

- .1 Service Fluid: Leachate Wastewater
 - .1 Max Operating Temp: 140°F
 - .2 Insulation Material: Mineral Wool
 - .3 Insulation Thickness: 1-1/2"
 - .4 Jacketing: Stainless Steel
 - .5 Heat Tracing: Electric

Part 4 Fabrication and Application

4.1 GENERAL

- .1 All surfaces to be insulated shall be free of all contaminants, including oil, grease, dirt, etc. All piping joints (including welded girth joints) shall be left unpainted and non-insulated until after completion of field pressure testing.
- .2 Insulation and accessory materials, other than cements and mastics, shall be applied only if dry. Stored insulation that has become wet or damaged shall be replaced.
- .3 Cracks, voids, break, and improperly fitted insulation shall be refitted or replaced. Excessive filling of cracks, voids, or holes with mastics or cements shall not be allowed.
- .4 Insulation that has been applied but not finished with weather barrier jackets or coating shall be protected from the weather or other sources of physical damage. If insulation shall become wet it shall be dried before the weather barrier with seal is applied.
- .5 Piping and other surfaces in the vicinity where insulation application is in progress shall be protected from dripping, splashing, or accidental application of coatings, mastics, or cements.
- .6 All insulation joints shall be installed butted together.
- .7 Each layer of insulation shall be installed with transverse and longitudinal joints staggered, and secured in place as specified.
- .8 Where studs, clips or pins are used for securing insulation, spacing shall be on approximately 18" centres for blanket insulation. Block insulation shall be installed with no less than 2 studs (clips or pins) per block. Split pins shall be spread, bent over, and imbedded into the face of the insulation.
- .9 When dual layer insulation systems employing different insulation materials are used for combined thermal and noise control, the insulation for noise control shall be installed as the outer layer. No credit for noise reduction may be taken for any insulation material in the system other than the mineral wool or fibrous glass.
- .10 Insulation systems for equipment and piping shall permit access to parts requiring maintenance without requiring destruction of the entire insulation system.
- .11 Jackets shall be sealed by sandwiching a flexible adhesive between all laps and at all valves, fittings, tracers on piping, to prevent entrance of water for the following insulation systems:
 - .1 The insulation system is considered as fireproofing.
 - .2 The insulation system is used for noise control.
 - .3 Electrically heat traced (EHT) systems.
 - .4 For shop installed insulation subject to exposed transportation to jobsite.
 - .5 Insulating cements shall not be used for sealing purposes.
- .12 All penetrations through the weatherproofing jacket shall be sealed with a flexible caulking compound. For piping, penetrations shall wherever possible, be in the lower 180° segment. Penetrations through the top shall be flashed and caulked.
- .13 For all insulation systems the finished insulation shall be neat in appearance. Vent valves, drain plugs, union, etc. shall be free of insulation to permit removal, unless indicated otherwise in tracing details.
- .14 A minimum clearance of 2" between the outside surface of any insulation and adjacent equipment or structural members shall be maintained.

Part 5 Inspection and Testing

5.1 GENERAL

- .1 Insulation systems shall be inspected periodically during construction for:
 - .1 Damaged or water soaked insulation.
 - .2 Cracks and unsealed joints.
- .2 When insulation is removed for any reason, adjacent surfaces shall be protected with a temporary weather barrier until restored to original condition.

Part 6 Standard Details

6.1 GENERAL

- .1 Refer to the following attached standard details:

Detail No.	Title
PD-6.01	General Arrangement - Insulation and Weatherproofing for Piping.
PD-6.02	Support for Insulation on Vertical Pipe.
PD-6.03	Insulation and Weatherproofing of Pipe Fittings.
PD-6.04	Insulation and Weatherproofing of Flanges and Steam Traced Pipe.
PD-6.05	General Arrangement - Insulation and Weatherproofing for Valves.
PD-6.06	General Arrangement - Removable Insulation Around Flange.
PD-6.07	Removable Insulation Around Valve.
PD-6.08	Insulation Detail at Pipe Supports

SHT. PD-6.01 GENERAL ARRANGEMENT INSULATION & WEATHERPROOFING FOR PIPING

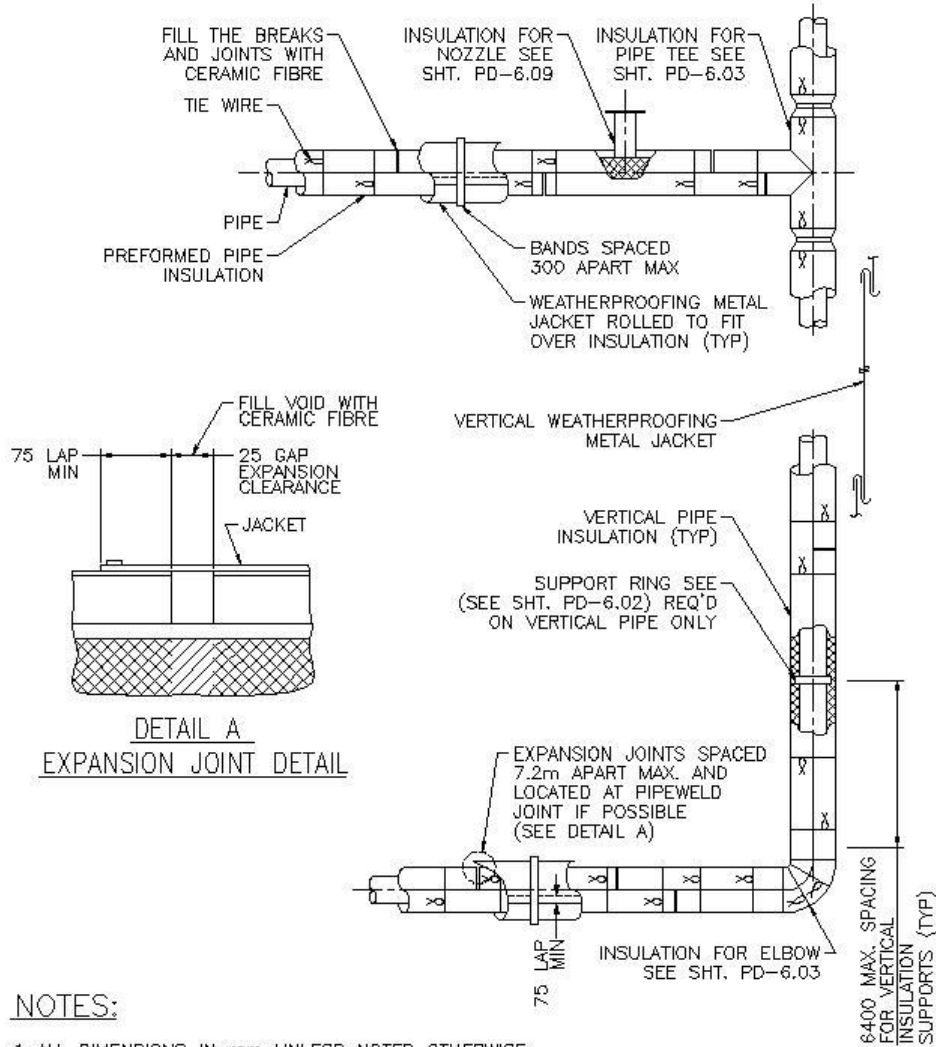

NOTES:

1. ALL DIMENSIONS IN mm UNLESS NOTED OTHERWISE.
2. FOR DETAILS OF VERTICAL JACKETING SEE SHT. PD-6.03

SHT. PD-6.02 SUPPORT FOR INSULATION ON VERTICAL PIPE

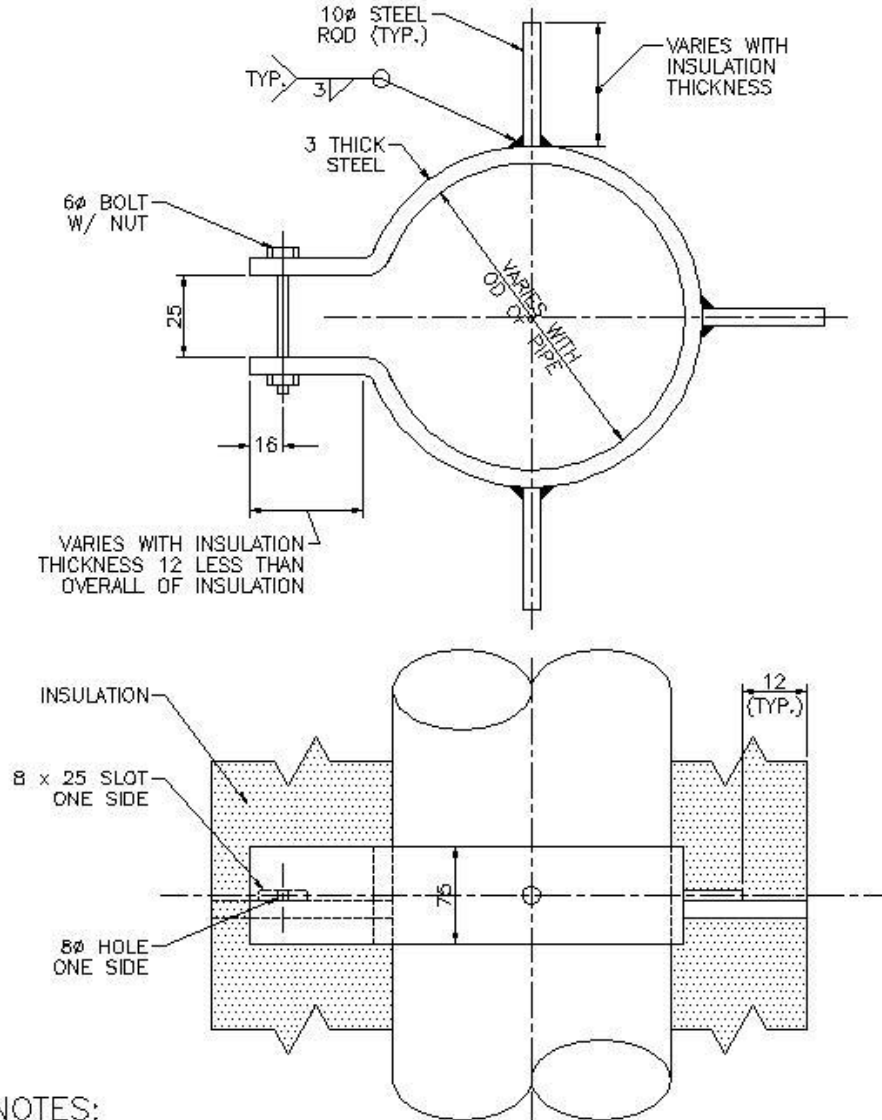

NOTES:

1. ALL DIMENSIONS IN mm UNLESS NOTED OTHERWISE

SHT. PD-6.03 INSULATION & WEATHERPROOFING FOR PIPE FITTINGS

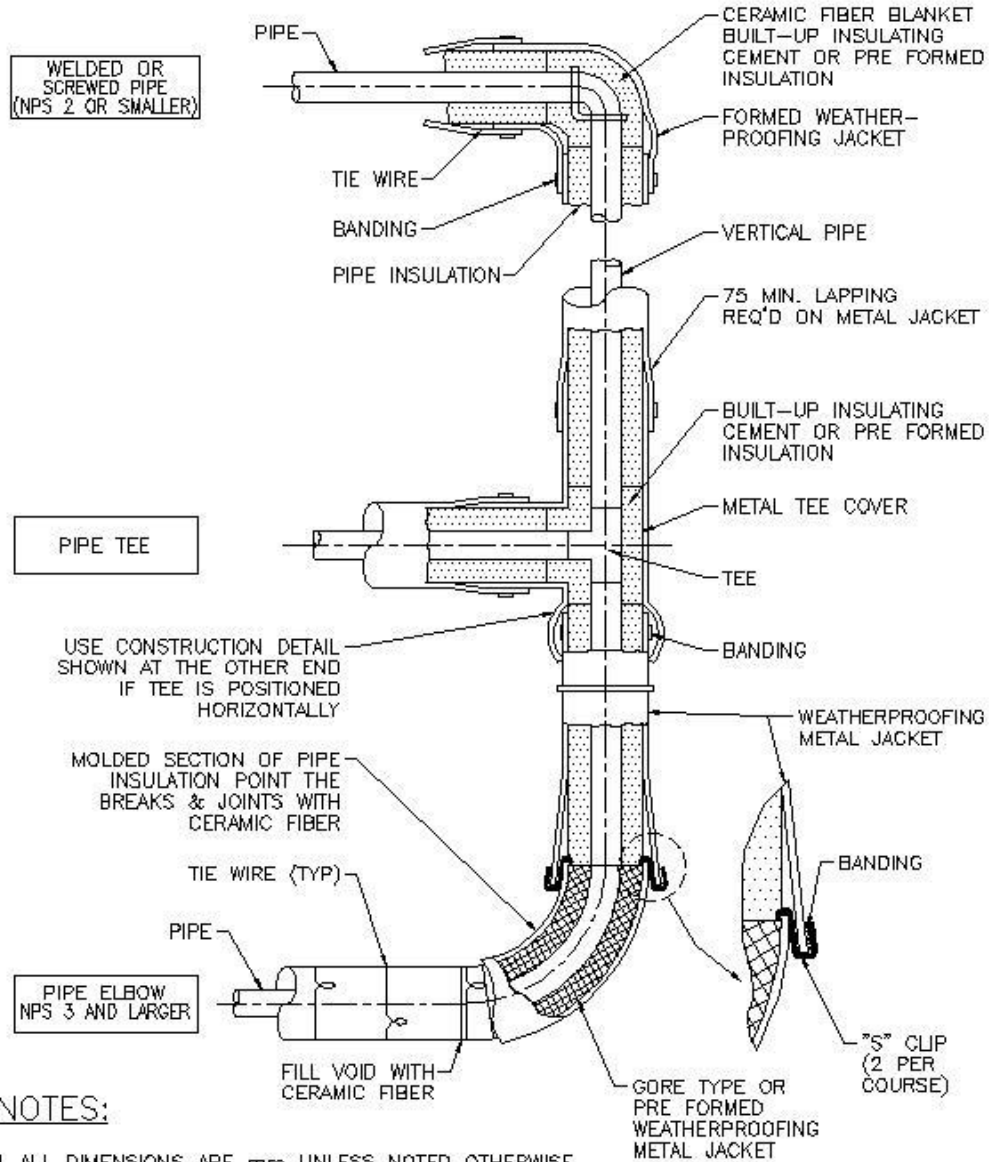

SHT. PD-6.04 INSULATION & WEATHERPROOFING OF FLANGES & STEAM TRACED PIPE

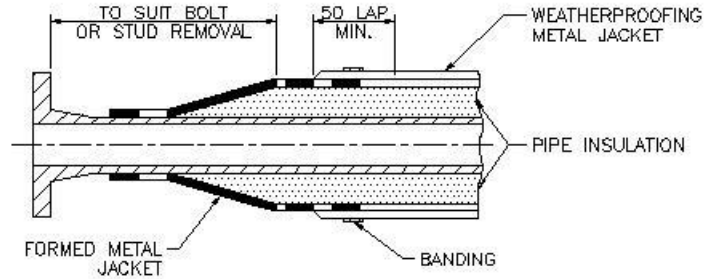

NON-INSULATED FLANGES
FOR INSULATED FLANGES SEE SHT. PD-6.06

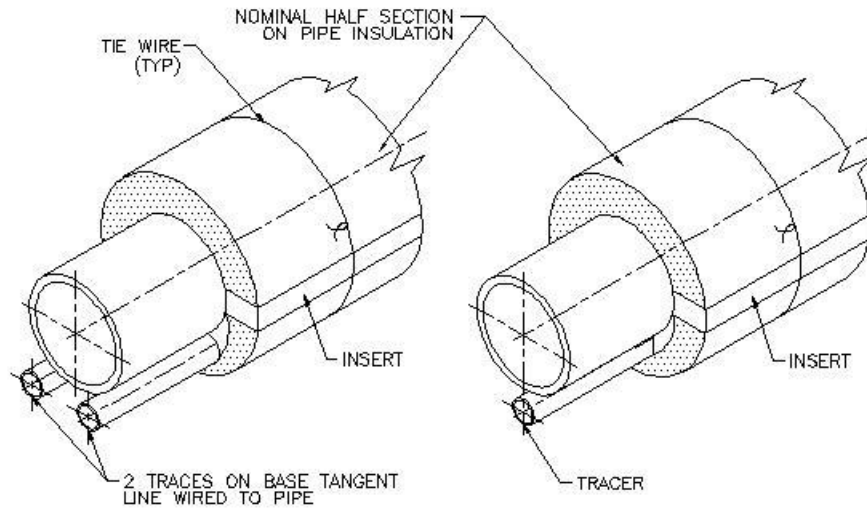

DOUBLE TRACED LINE

SINGLE TRACED LINE

NOTES:

1. TRACER PROTRUSIONS MAY BE INSULATED WITH 3mm THICK THERMO FAB TAPE.
2. INSERTS ADDED TO HALF SECTIONS OR OVERSIZED PREFORMED HALF SECTIONS.
3. ALL DIMENSIONS IN mm UNLESS NOTED OTHERWISE.

SHT. PD-6.05 GENERAL ARRANGEMENT INSULATION & WEATHERPROOFING FOR VALVES

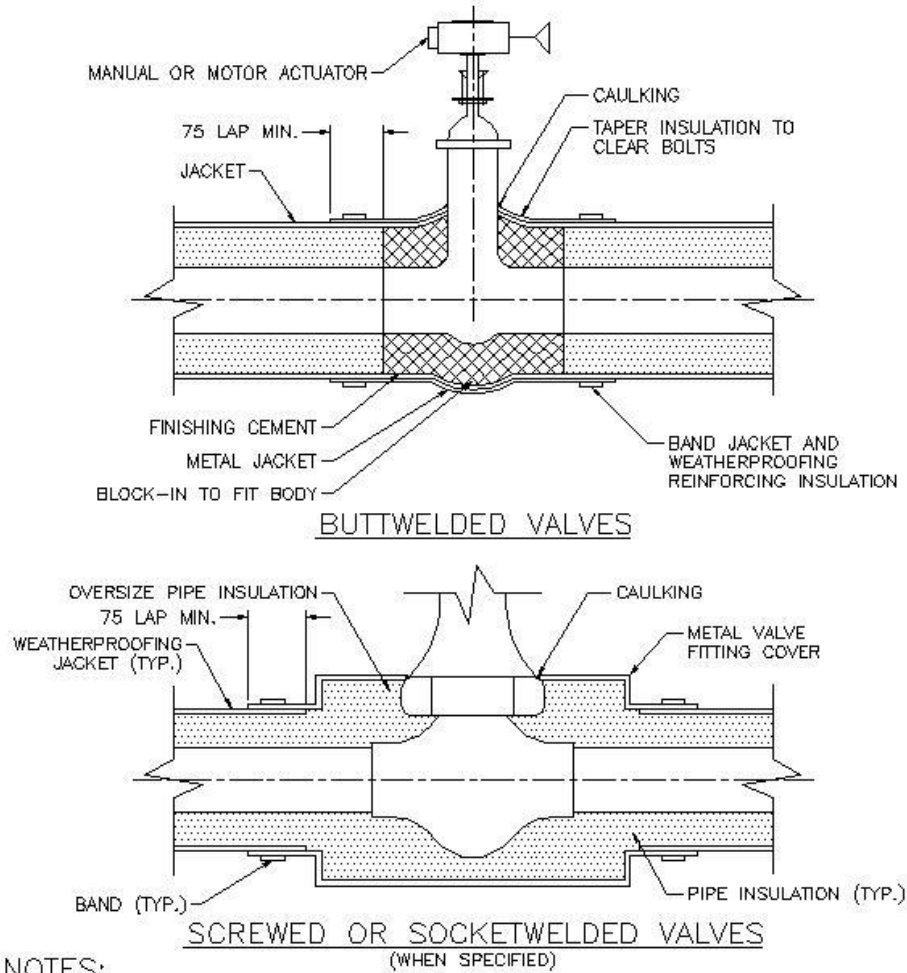

NOTES:

1. ALTERNATIVE INSULATION METHODS MAY BE USED SUBJECT TO PRIOR WRITTEN APPROVAL OF PURCHASER.
2. SEE SHT. PD-8.07 FOR REMOVABLE TYPE VALVE INSULATION FOR FLANGED VALVES.
3. ALL DIMENSIONS IN mm UNLESS NOTED OTHERWISE.

SHT. PD-6.06 GENERAL ARRANGEMENT REMOVABLE INSULATION AROUND FLANGES

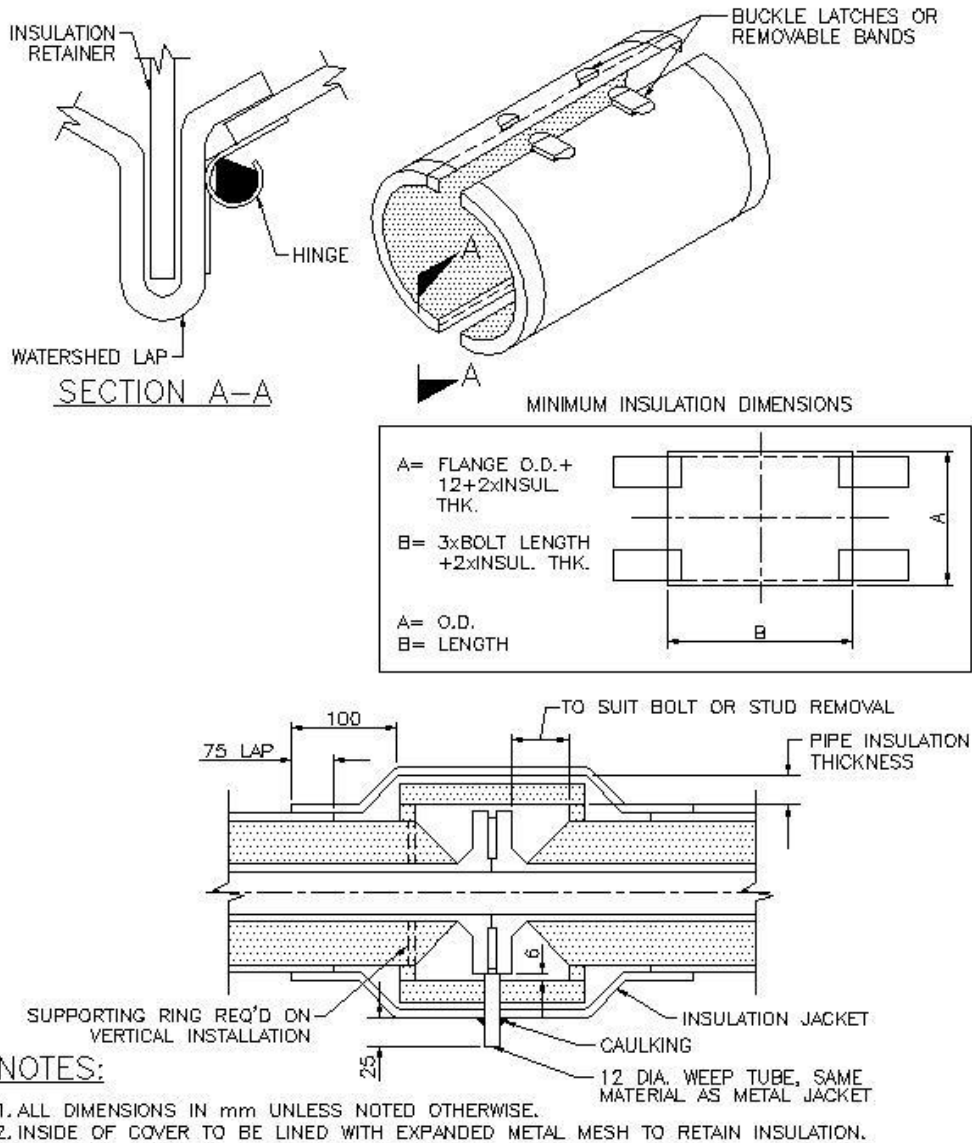

SHT. PD-6.07 REMOVABLE INSULATION AROUND VALVES

MINIMUM INSULATION DIMENSIONS

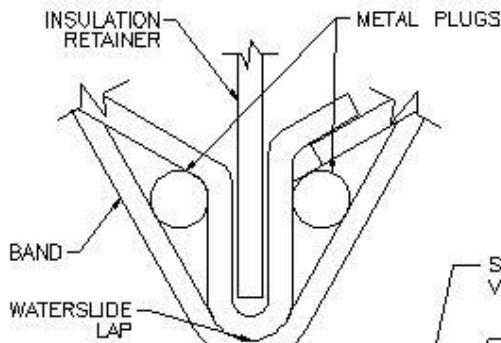
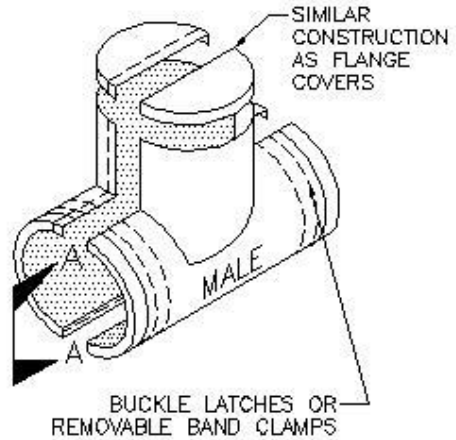
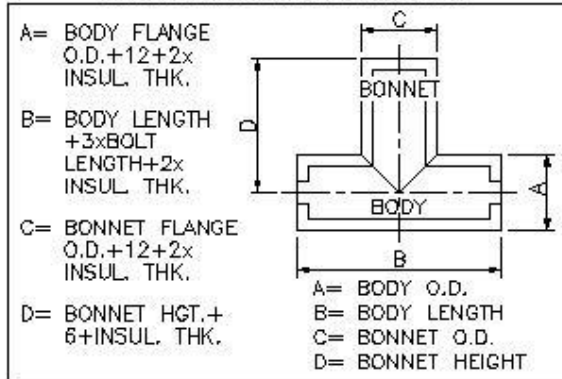

SECTION A-A

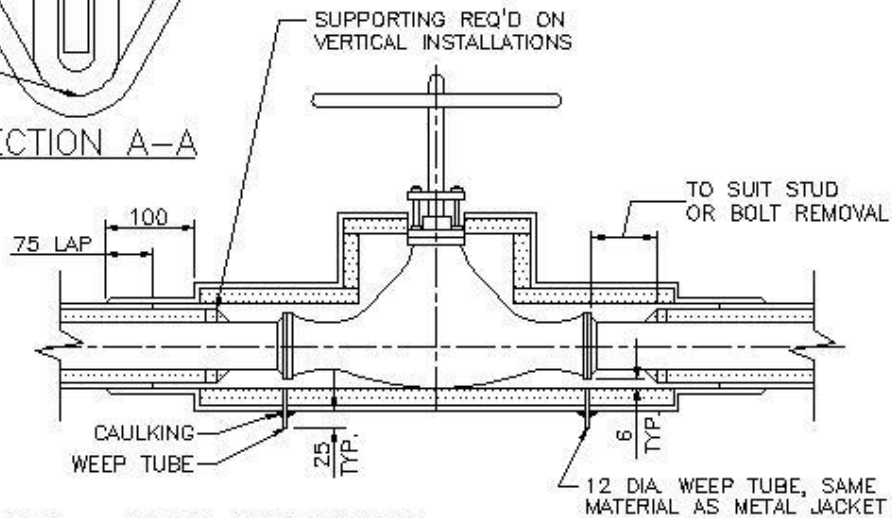

NOTES:

1. ALL DIMENSIONS IN mm UNLESS NOTED OTHERWISE.
2. ALTERNATIVE METAL WEATHER PROOFING COVERS MAY BE USED SUBJECT TO PRIOR WRITTEN APPROVAL OF PURCHASER

SHT. PD-6.08 INSULATION DETAILS AT PIPE SUPPORTS

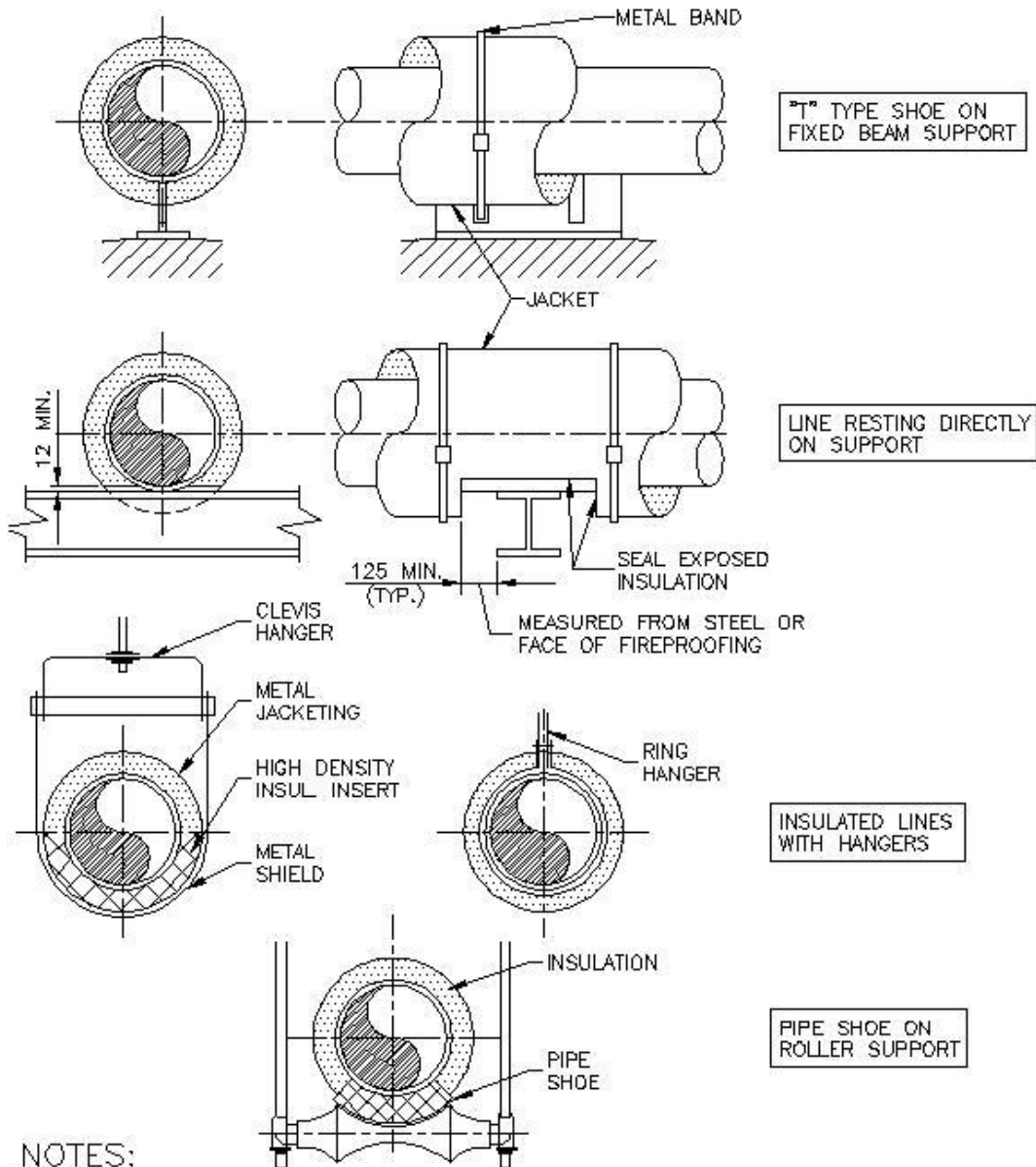

NOTES:

1. ALL DIMENSIONS IN mm UNLESS NOTED OTHERWISE.

END OF SECTION