

EXISTING BRIDGE DECK PLAN
1:100
(ONLY SOFFIT AND INTERIOR DIAPHRAGM REPAIRS SHOWN)

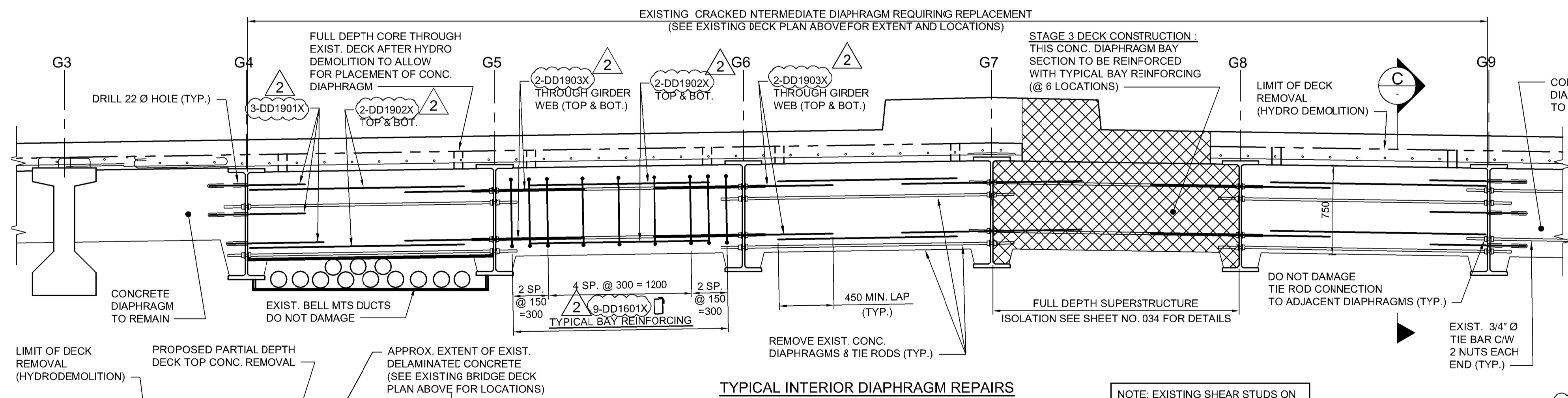

TYPICAL INTERIOR DIAPHRAGM REPAIRS

A SECTION
1:25

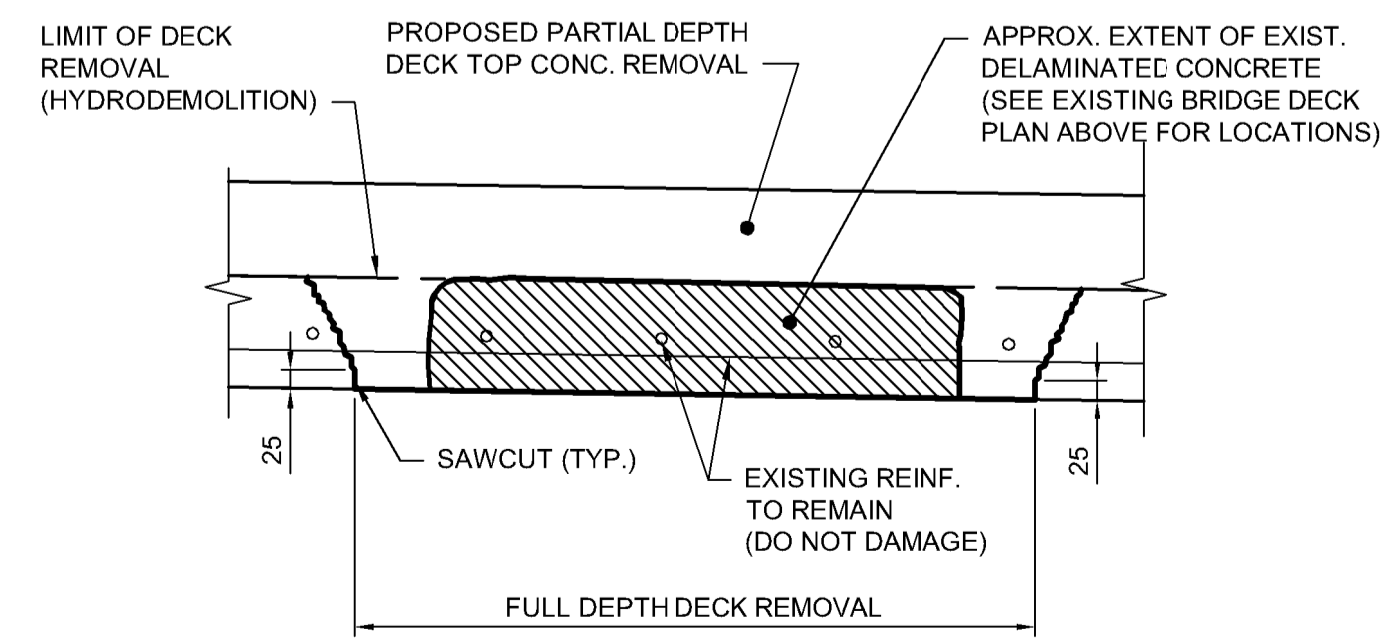

TYPICAL DECK SOFFIT DELAMINATION REPAIR

B SECTION
1:10

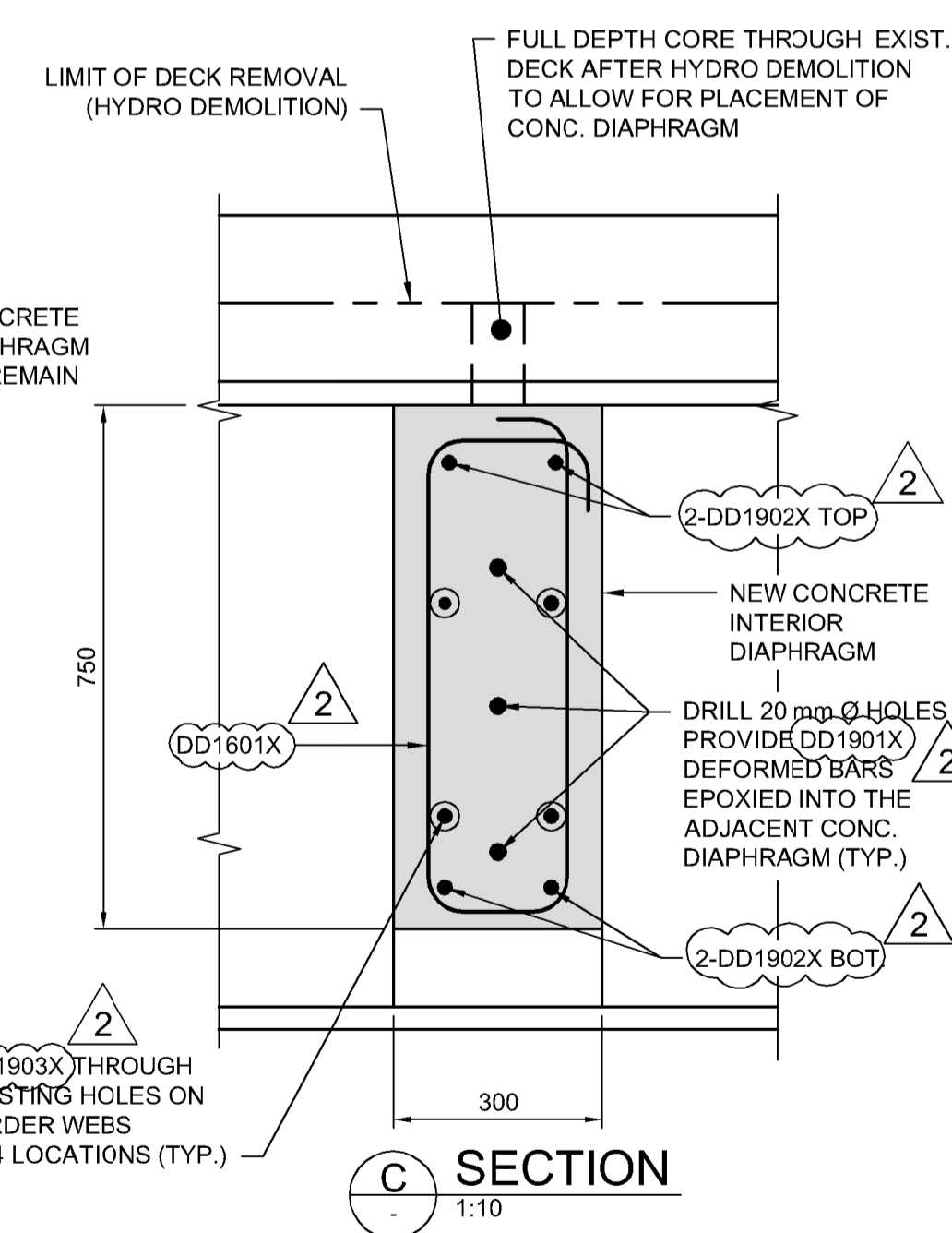

C SECTION
1:10

- LEGEND**
- APPROXIMATE AREA OF DELAMINATION ON DECK SOFFIT REQUIRING FULL DEPTH REPAIR
 - CRACKED INTERMEDIATE DIAPHRAGM REQUIRING REPLACEMENT

- NOTES:**
- FULL DEPTH REPAIRS:**
- AREAS OF SOFFIT DELAMINATION SHOWN ARE APPROXIMATE. DELAMINATED AREAS TO BE MAPPED OUT ON SITE BY THE CONTRACT ADMINISTRATOR PRIOR TO ANY BRIDGE DECK WORKS.
 - DUE TO THE EXISTING CONDITION OF THE DECK AS WELL AS THE PROPOSED EXTENT OF REMOVAL THE CONTRACTOR IS ADVISED THAT THE POSSIBILITY EXISTS FOR BLOW THROUGH TO OCCUR. ANY BLOW THROUGH WILL REQUIRE A FULL DEPTH REPAIR SIMILAR TO THAT SHOWN ON THIS SHEET.
 - AREAS OF DELAMINATION SHALL BE HYDRODEMOLISHED FULL DEPTH OF THE SLAB. EXISTING LOWER REINFORCEMENT MAT TO REMAIN (DO NOT DAMAGE). EDGES OF DELAMINATION TO BE FINISHED WITH A 25 mm SAWCUT.
 - SECURE REPAIR FORMWORK TO DECK SOFFIT.
 - CAST FULL-DEPTH REPAIR AT TIME OF DECK CASTING.
- INTERIOR DIAPHRAGM REPAIRS:**
- COMPLETE PARTIAL DEPTH HYDRO DEMOLITION OF DECK FOLLOWED BY CAREFUL REMOVAL OF THE INTERIOR DIAPHRAGMS DESIGNATED FOR REPLACEMENT.
 - CORE HOLES THROUGH DECK AT EACH DIAPHRAGM (MINIMUM 2 PER DIAPHRAGM) FOR CASTING CONCRETE.
 - INSTALL NEW REINFORCEMENT, FORM DIAPHRAGM AND CAST NEW CONCRETE.
 - IF POSSIBLE, THE CONTRACTOR MAY OPT TO PROVIDE A FULL DEPTH REMOVAL OVER THE INTERIOR DIAPHRAGM (SIMILAR TO AT THE PIER DIAPHRAGMS) TO FACILITATE DIAPHRAGM REPLACEMENT.

APEGM
Certificate of Authorization
Dillon Consulting Limited (MB)
No. 1789 Date: 2018/02/09

NO.	REVISIONS	DATE	BY
1	ADDENDUM #2	18/02/22	DRA
0	ISSUED FOR TENDER	18/02/09	DRA

DESIGNED BY	DRA	CHECKED BY	SSR
DRAWN BY	NBG	APPROVED BY	MBL
HOR. SCALE	AS SHOWN	RELEASED FOR CONSTRUCTION	
VERTICAL	AS SHOWN	DATE	2018/02/09

ENGINEER'S SEAL
PROVINCE OF MANITOBA
D.R.C. AMORIM
Member
33215
REGISTERED PROFESSIONAL ENGINEER
CONSULTANT PROJECT NUMBER
17-5932

THE CITY OF WINNIPEG
PUBLIC WORKS DEPARTMENT

FERMOR AVENUE BRIDGE OVER SEINE RIVER
BRIDGE REHABILITATION, PEDESTRIAN-CYCLIST UNDERPASS STRUCTURE AND ROADWORKS FROM ST. ANNE'S ROAD TO ARCHIBALD STREET

CITY DRAWING NUMBER
B-118-2017-CS-029

SHEET
029 OF 100

CONSULTANT DRAWING NUMBER
CS-029

EXISTING BRIDGE DECK UNDERSIDE REPAIRS

G:\CAD\175932\Drawings\Structural\BRIDGE\CON-CS-EXISTING BRIDGE DECK DELA.dwg