

**1 BARRIER CURB AND GUTTER**

SCALE: 1:10

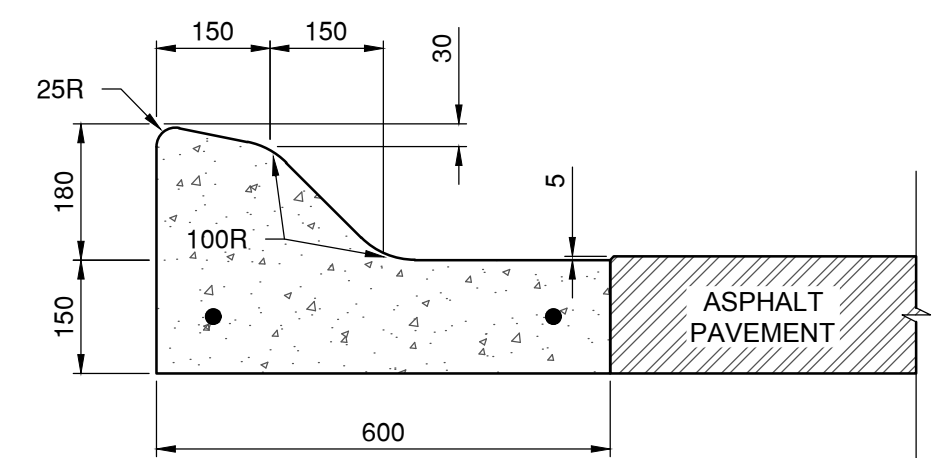

**2 MODIFIED BARRIER CURB AND GUTTER**

SCALE: 1:10

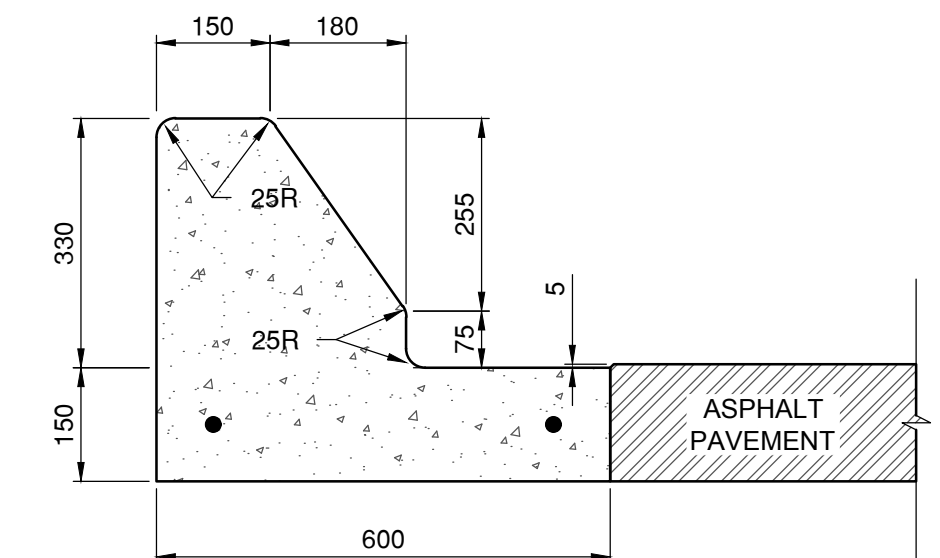

**3 SAFETY CURB AND GUTTER**

SCALE: 1:10

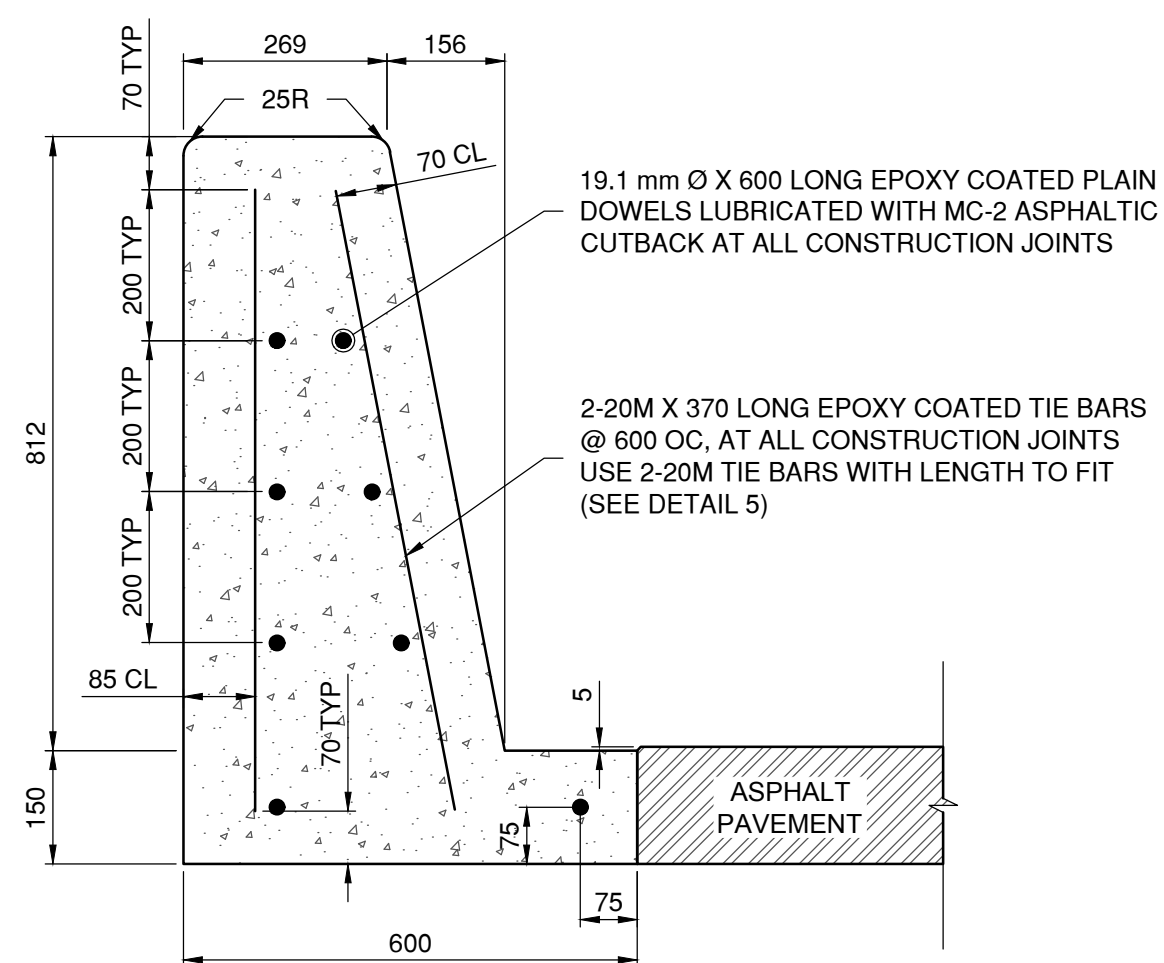

**4 CONSTANT SLOPE BRIDGE BARRIER**

SCALE: 1:10

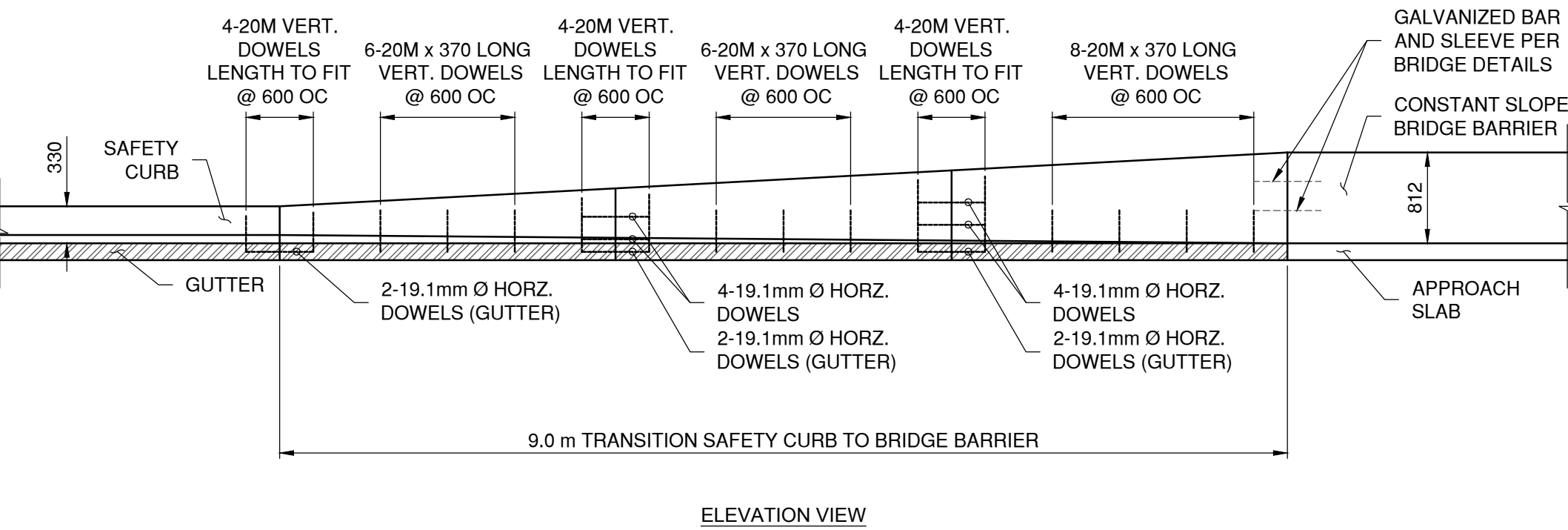
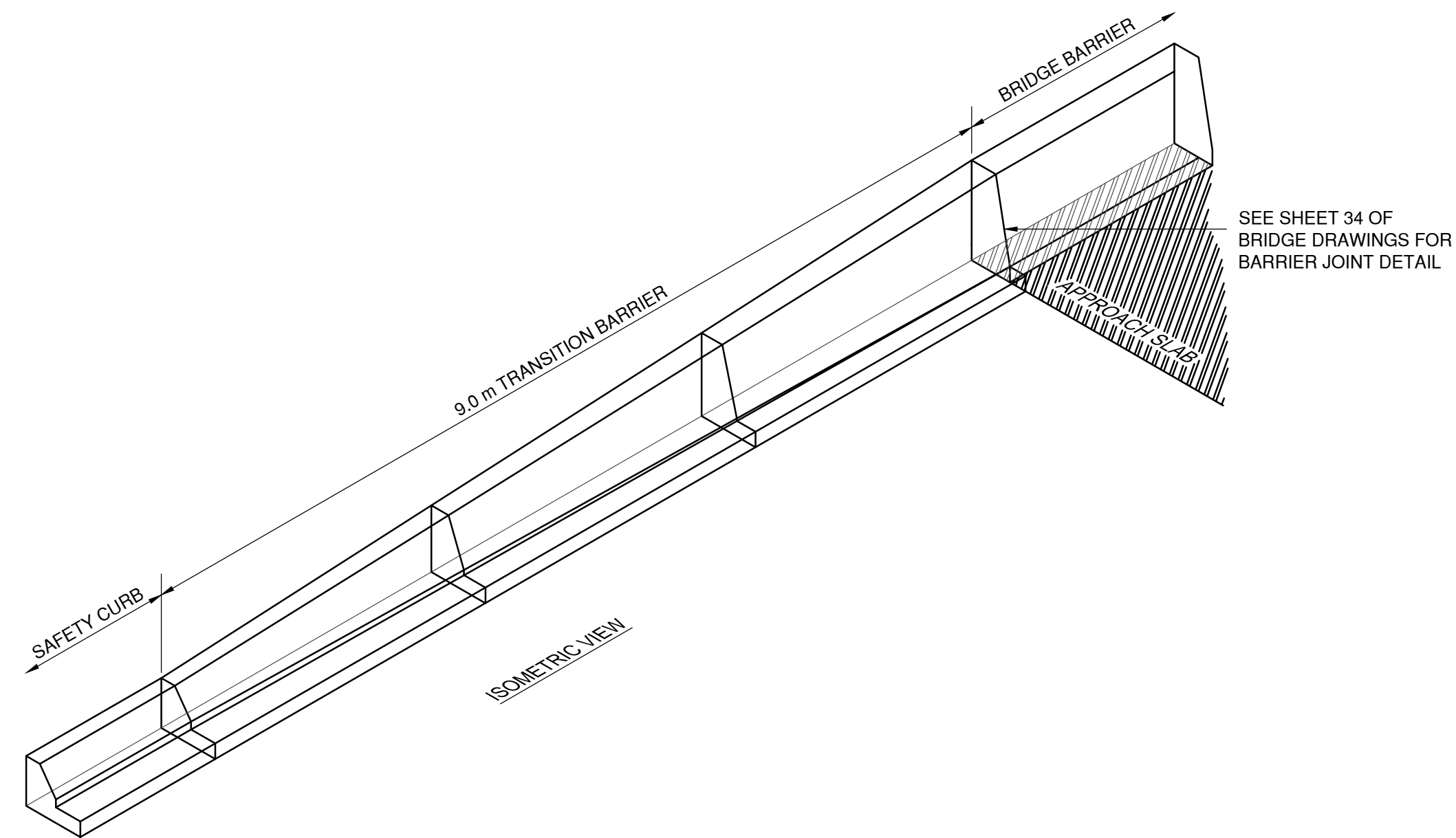

**5 TRANSITION DETAIL: SAFETY CURB TO CONSTANT SLOPE BRIDGE BARRIER**

SCALE: 1:50

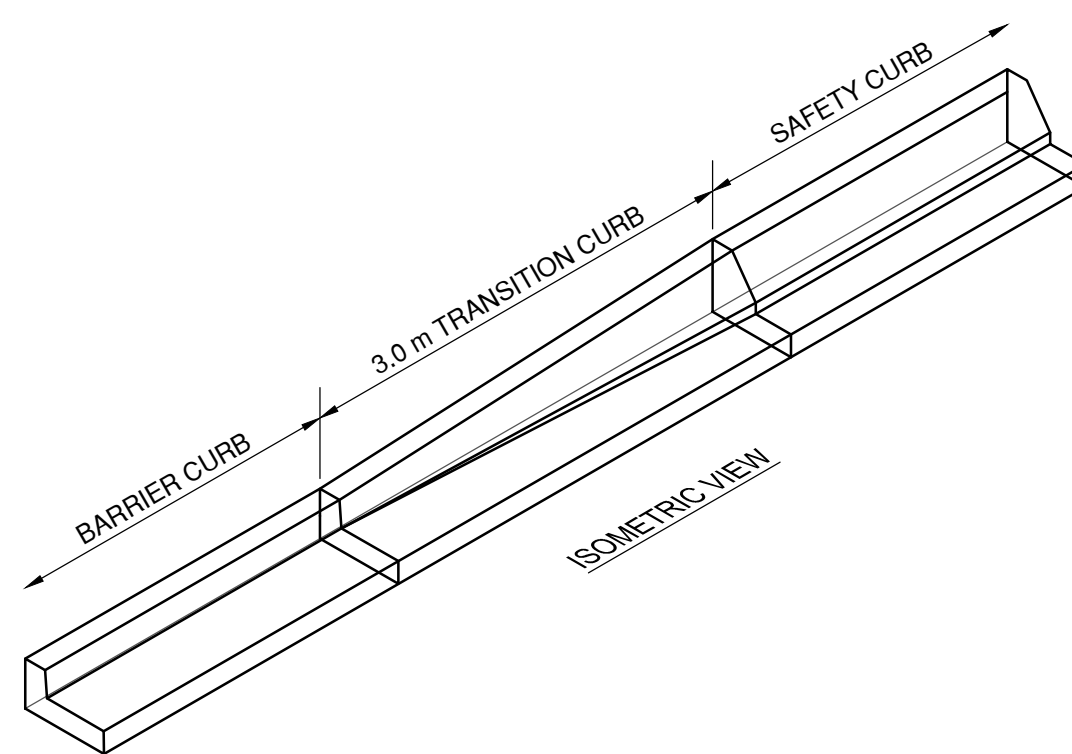

**6 TRANSITION DETAIL BARRIER CURB TO SAFETY CURB**

SCALE: 1:50

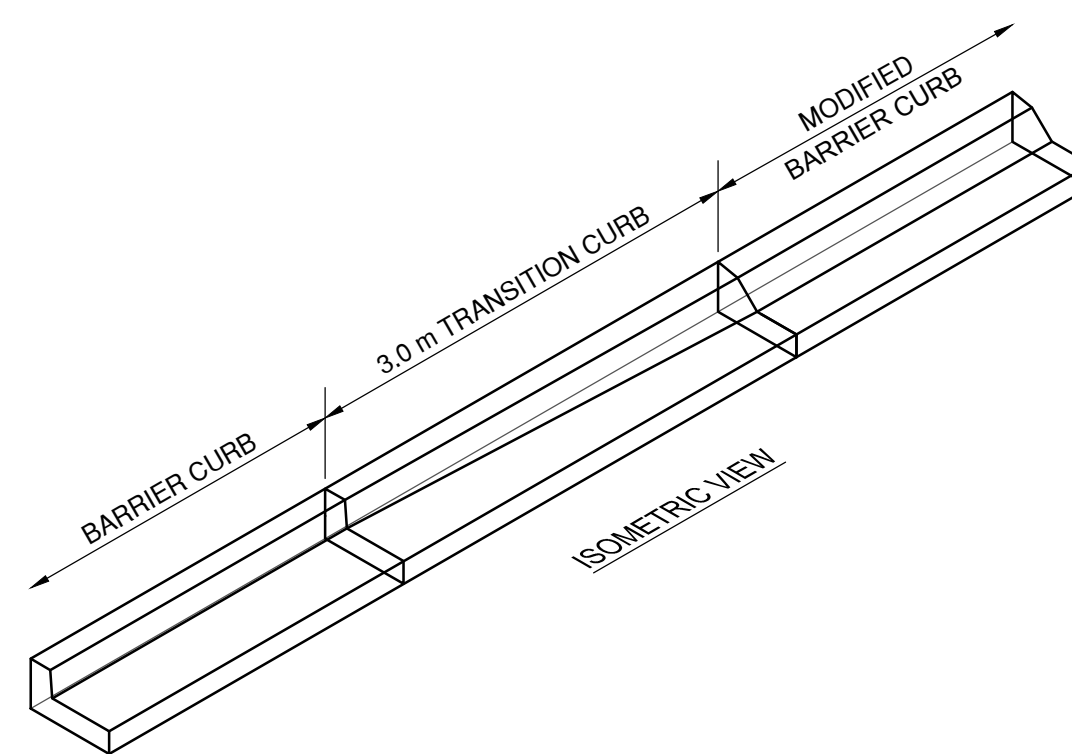

**7 TRANSITION DETAIL BARRIER CURB TO MODIFIED CURB**

SCALE: 1:50

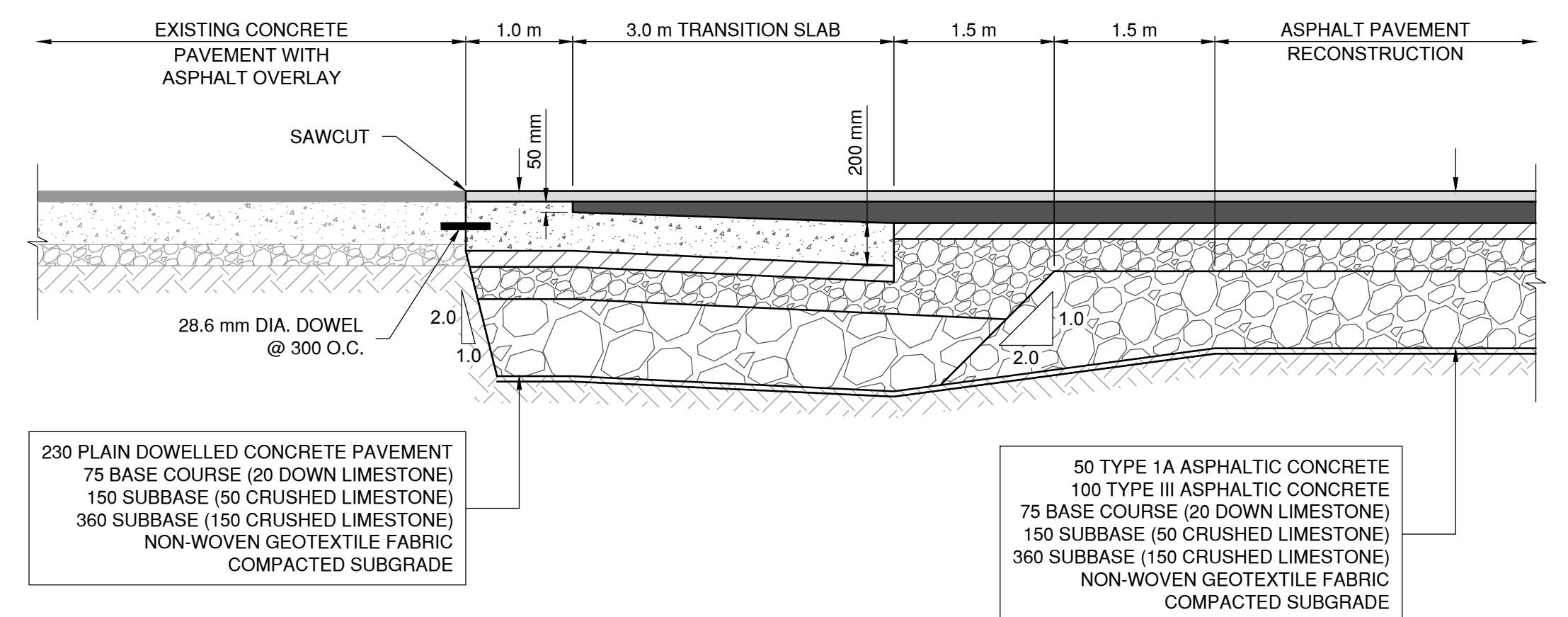

**8 TIE-IN DETAIL: EXISTING CONCRETE WITH ASPHALT OVERLAY TO FULL-DEPTH ASPHALT RECONSTRUCTION**

SCALE: H-1:50 V-1:25

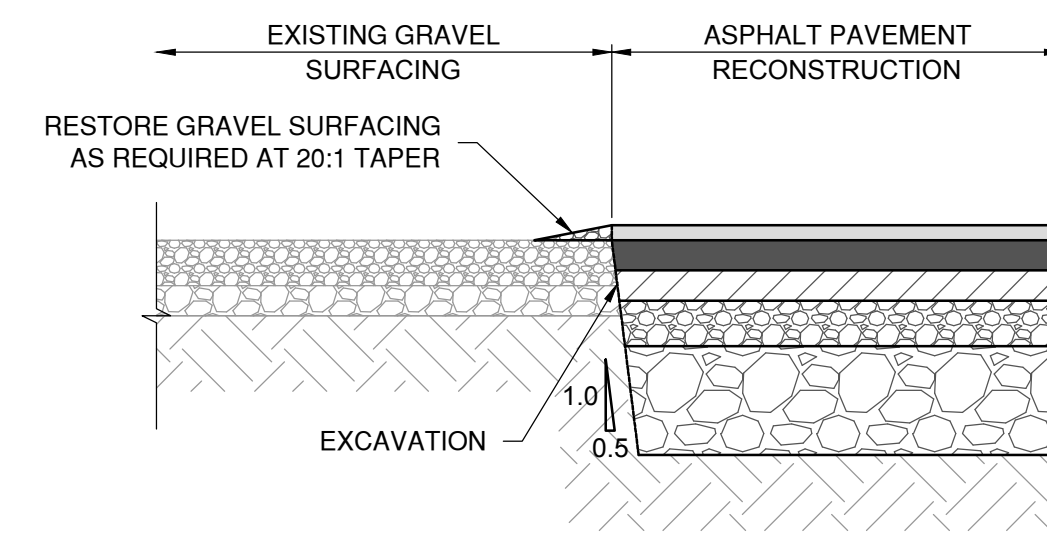

**9 TIE-IN DETAIL: GRAVEL SURFACING TO FULL-DEPTH ASPHALT RECONSTRUCTION**

SCALE: H-1:100 V-1:25

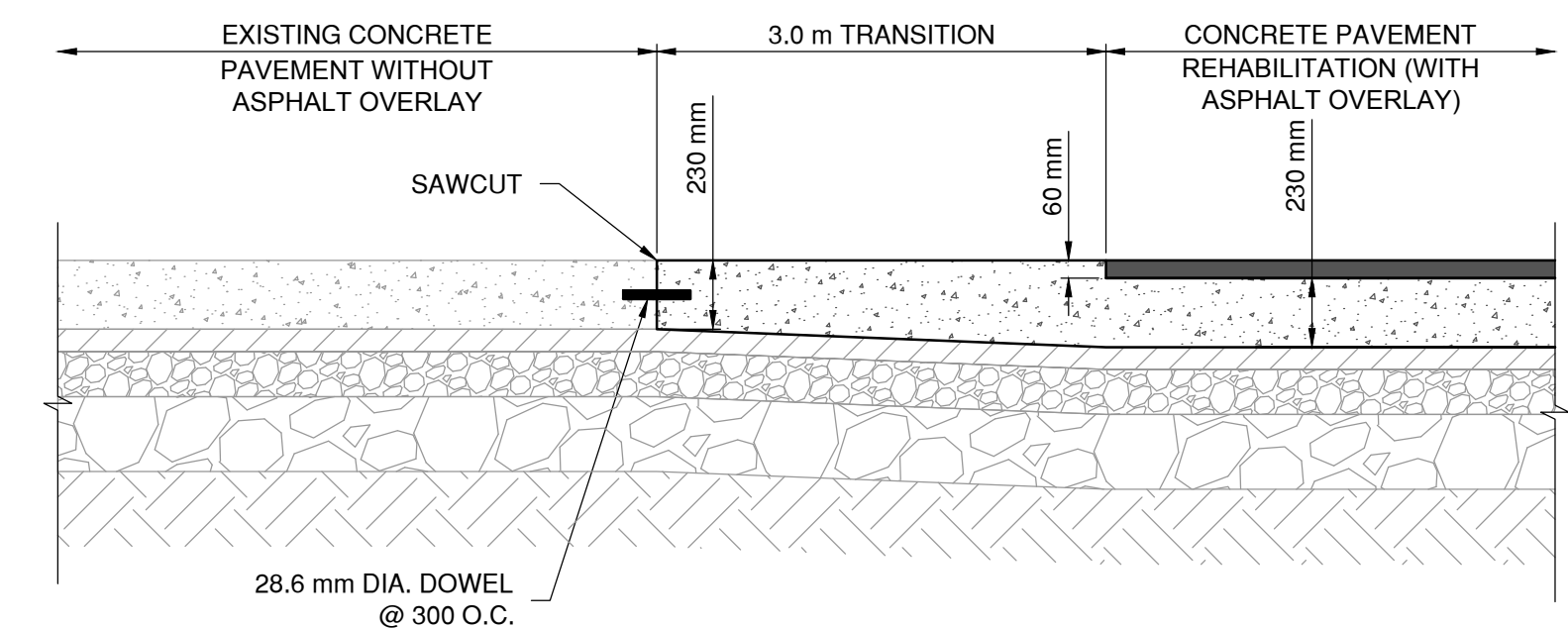

**10 TIE-IN DETAIL: EXISTING CONCRETE PAVEMENT TO CONCRETE REHABILITATION WITH ASPHALT OVERLAY**

SCALE: H-1:50 V-1:25

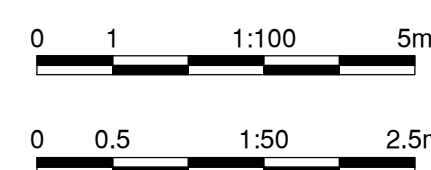

B.M. CITY OF WINNIPEG 40-42  
ELEV. 238.985m



DESIGNED BY	DRA	CHECKED BY	AF
DRAWN BY	MT	APPROVED BY	EFS
HOR. SCALE:	AS SHOWN	ACCEPTED BY	DATE
VERTICAL:	AS SHOWN	ORIGINAL DRAWING SIGNED BY	17.10.04
NO.	ISSUED FOR TENDER	DATE	17.10.04
NO.	REVISIONS	DATE	BY

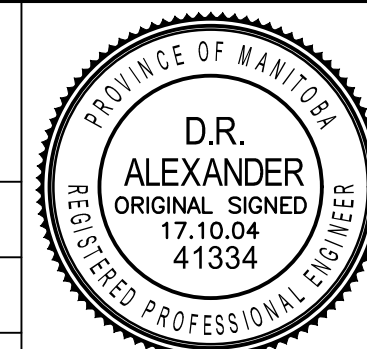

CONSULTANT DRAWING NO. 1600070700-C0058



**THE CITY OF WINNIPEG**  
PUBLIC WORKS DEPARTMENT  
ENGINEERING DIVISION

SASKATCHEWAN AT STURGEON CREEK  
BRIDGE CONSTRUCTION

CITY DRAWING NUMBER

P3487-17-202

SHEET 58 OF 69

SASKATCHEWAN AVENUE ROADWORKS  
TYPICAL ROADWAY DETAILS

58