

Section A-A

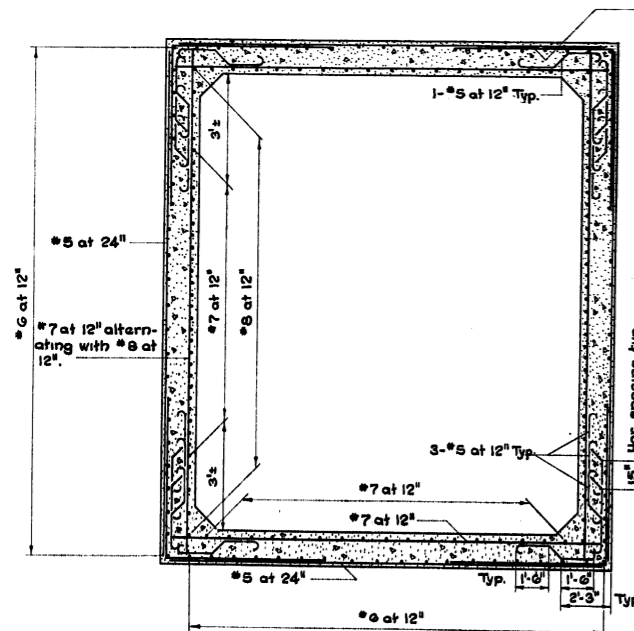

Section B-B

Note: Shear bars are shown made of vert. steel for clarity. For construction, place outside of vert. steel.

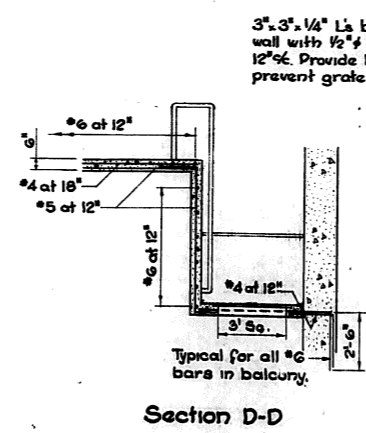

Section D-D

For dowels in Control Room Floor for back wall see Section C-C, Dwg. No. G-217

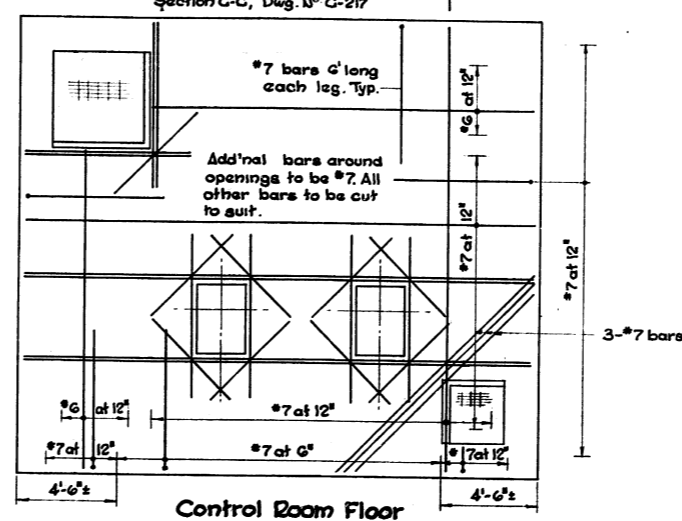

Control Room Floor

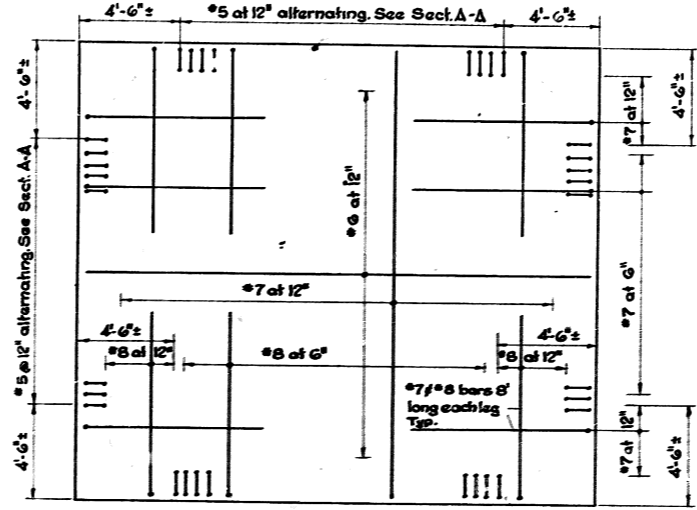

Wet Well Floor

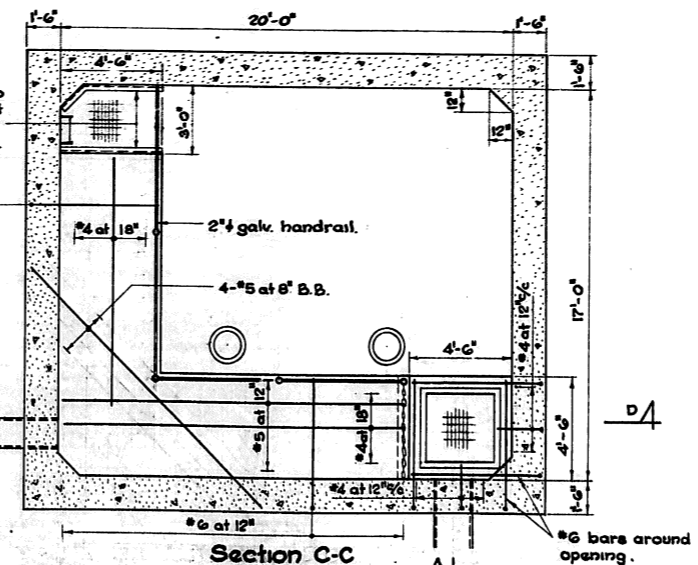

Section C-C

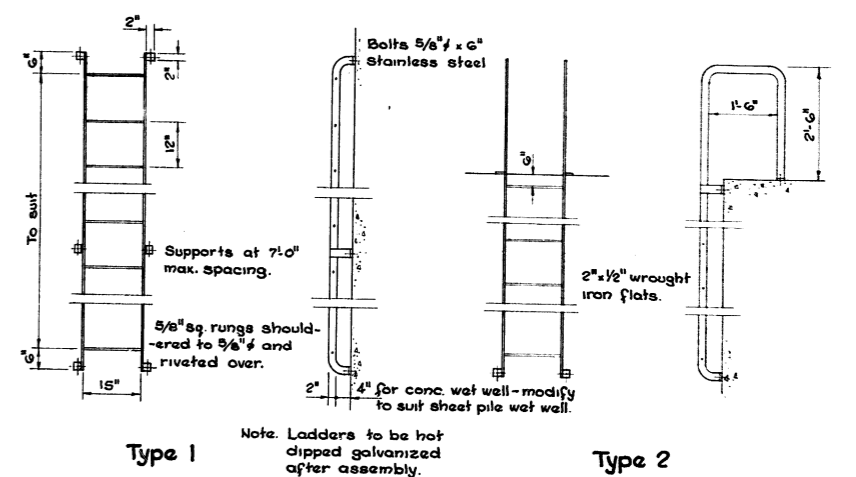

Ladder Details

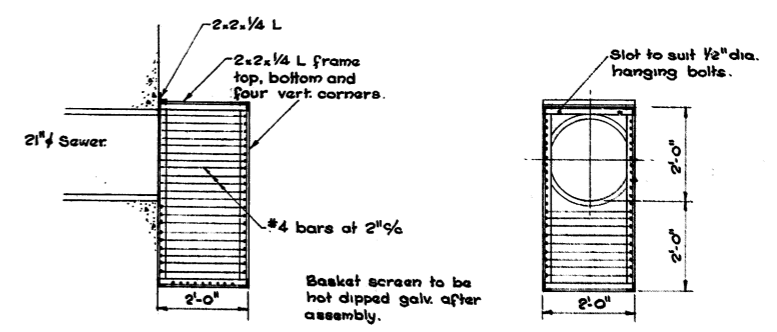

Basket Screen Detail



DAMAS AND SMITH LIMITED
CONSULTING ENGINEERS
TORONTO · LONDON · WINNIPEG

THE METROPOLITAN CORPORATION OF GREATER WINNIPEG
STREETS AND TRANSIT DIVISION

RELOCATION OF ROUTE 20

ALTERNATIVE No. 1
WET WELL LAYOUT - REINFORCED CONCRETE

REV.	BY	DATE	DESCRIPTION	DRAWN	CHECKED	DATE	APPROVED	DRAWING No.
1	R.B.	Oct. 67	BASKET SCREEN REVISED.	RJB		SEPT. 1967	<i>[Signature]</i> Engineer of Streets and Traffic	785-G218

