

APPENDIX 'B'

MANITOBA HYDRO PRECAST BASE DETAILS

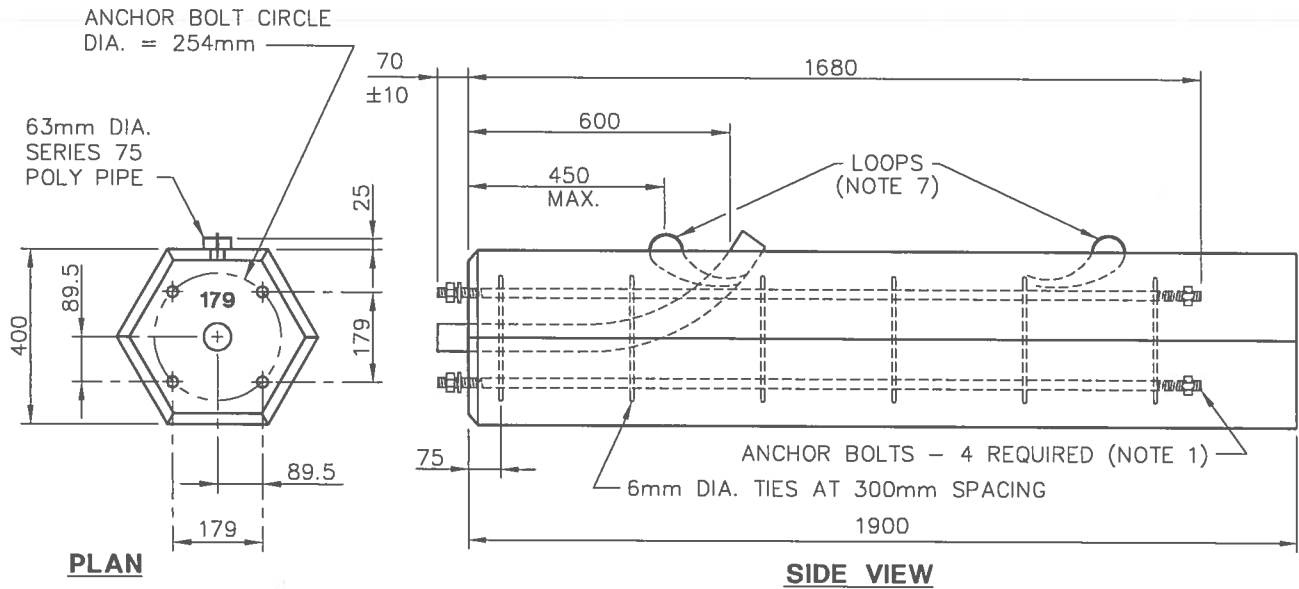

NOTES:

1. ANCHOR BOLTS SHALL BE 25mm x 1750mm LONG GRADE 300W AS PER CSA G40.21M THREADED 100mm AT BOTH ENDS. ONE END OF EACH ANCHOR BOLT SHALL BE GALVANIZED FOR A MINIMUM LENGTH OF 150mm AND SHALL BE SUPPLIED C/W TWO 25mm HEX NUTS AND A FLAT ROUND WASHER. ONE NUT SHALL BE THREADED ONTO THE EMBEDDED END OF EACH ANCHOR BOLT. ALL MATERIAL INCLUDING NUTS AND WASHERS TO BE HOT DIPPED GALVANIZED IN ACCORDANCE WITH CSA G164-M.
2. THE PRECAST CONCRETE BASE SHALL CONFORM TO C.S.A. SPECIFICATION CAN3-A23.1 AND CAN3-A23.4.
3. CEMENT SHALL BE TYPE 50, SULPHATE RESISTANT AND SHALL CONFORM TO C.S.A. SPECIFICATION CAN/CSA-A5/A8/A362.
4. CONCRETE TO HAVE A MINIMUM SPECIFIED COMPRESSIVE STRENGTH OF 35 MP_o AT 28 DAYS, MAX. WATER/CEMENT RATIO OF 0.45, WITH ENTRAINED AIR OF 5-8%.
5. MINIMUM CONCRETE COVER ON ALL REINFORCING STEEL SHALL BE 50mm.
6. 25mm CHAMFER ON ALL EXPOSED CONCRETE EDGES.
7. BASES SHALL BE EQUIPPED WITH 2 SIDE LIFTING LOOPS OF 3 STRAND x 4.0mm GRADE 130 (MIN. BREAKING STRENGTH =25kN) GALVANIZED STEEL WIRE. THE LOOPS SHALL BE CENTERED ON THE BALANCE POINT WITH THE UPPER LOOP A MAXIMUM OF 450mm FROM THE TOP OF THE BASE. THE LOOPS SHALL HAVE A MINIMUM INTERNAL CLEARANCE OF 75mm AND THE ENDS OF THE WIRE SHALL BE IMBEDDED A MINIMUM OF 300mm.
8. EACH BASE SHALL BE EQUIPPED WITH A PROMINENT VEE GROOVE LOCATED IN THE CHAMFER OF THE BASE TO INDICATE THE LOCATION OF THE POLY PIPE.
9. EACH BASE SHALL HAVE THE NUMBER 179 INDENTED (OR OTHERWISE PERMANENTLY MARKED) ON THE TOP OF THE BASE.

APPROVED ORIGINAL DRAWING SEALED BY E.H. WIEBE 90-04-06	REVISIONS		MANITOBA HYDRO DISTRIBUTION STANDARDS	
	02 03	9	REVISED NOTE 1, THREAD & NUTS ADDED	STANDARD PRECAST CONCRETE BASE FOR 7.7m METAL STREET LIGHT POLES
	99- 06	8	C.S.A. SPEC. DATES REMOVED IN NOTES 1,2 AND 3.	
95- 08	7	INCREASED SIZE OF POLY PIPE		
DRAWN R.L.B./CAD	CHECKED	DATE ORIG. 73-06	CK 15-6 M	
			SHT. 0001	REV. 09

1-04435-DA-24623-0003