



THE CITY OF WINNIPEG

TENDER

TENDER NO. 1095-2019

SUPPLY AND DELIVERY OF BUS OPERATOR JACKETS

TABLE OF CONTENTS

PART A - BID SUBMISSION

Form A: Bid	1
Form B: Prices	4

PART B - BIDDING PROCEDURES

B1. Contract Title	1
B2. Submission Deadline	1
B3. Enquiries	1
B4. Confidentiality	1
B5. Addenda	1
B6. Substitutes	2
B7. Bid Submission	3
B8. Bid	3
B9. Prices	4
B10. Disclosure	5
B11. Conflict of Interest and Good Faith	5
B12. Qualification	6
B13. Opening of Bids and Release of Information	7
B14. Irrevocable Bid	7
B15. Withdrawal of Bids	8
B16. Evaluation of Bids	8
B17. Award of Contract	8

PART C - GENERAL CONDITIONS

C0. General Conditions	1
------------------------	---

PART D - SUPPLEMENTAL CONDITIONS

General

D1. General Conditions	1
D2. Unfair Labour Practices	1
D3. Scope of Work	1
D4. Cooperative Purchase	1
D5. Definitions	2
D6. Contract Administrator	2
D7. Ownership of Information, Confidentiality and Non Disclosure	2
D8. Notices	2

Submissions

D9. Authority to Carry on Business	3
------------------------------------	---

Schedule of Work

D10. Commencement	3
D11. Delivery	3
D12. Liquidated Damages	3
D13. Orders	4
D14. Records	4

Measurement and Payment

D15. Invoices	4
D16. Payment	4

Warranty

D17. Warranty	5
---------------	---

PART E - SPECIFICATIONS

General

E1. Applicable Specifications	1
E2. Goods	1

E3. Components	3
E4. Slide Fasteners	4
E5. Trim Components	4
E6. Cutting	5
E7. Sewing	5
E8. Shoulder Flashes	5
E9. Construction	5
E10. Measurements and Sizing	12

PART B - BIDDING PROCEDURES

B1. CONTRACT TITLE

B1.1 SUPPLY AND DELIVERY OF BUS OPERATOR JACKETS

B2. SUBMISSION DEADLINE

B2.1 The Submission Deadline is 4:00 p.m. Winnipeg time, December 6, 2019.

B2.2 Bids determined by the Manager of Materials to have been received later than the Submission Deadline will not be accepted and will be returned upon request.

B2.3 The Contract Administrator or the Manager of Materials may extend the Submission Deadline by issuing an addendum at any time prior to the time and date specified in B2.1.

B3. ENQUIRIES

B3.1 All enquiries shall be directed to the Contract Administrator identified in D6.1.

B3.2 If the Bidder finds errors, discrepancies or omissions in the Tender, or is unsure of the meaning or intent of any provision therein, the Bidder shall promptly notify the Contract Administrator of the error, discrepancy or omission at least five (5) Business Days prior to the Submission Deadline.

B3.3 Responses to enquiries which, in the sole judgment of the Contract Administrator, require a correction to or a clarification of the Tender will be provided by the Contract Administrator to all Bidders by issuing an addendum.

B3.4 Responses to enquiries which, in the sole judgment of the Contract Administrator, do not require a correction to or a clarification of the Tender will be provided by the Contract Administrator only to the Bidder who made the enquiry.

B3.5 The Bidder shall not be entitled to rely on any response or interpretation received pursuant to B3 unless that response or interpretation is provided by the Contract Administrator in writing.

B4. CONFIDENTIALITY

B4.1 Information provided to a Bidder by the City or acquired by a Bidder by way of further enquiries or through investigation is confidential. Such information shall not be used or disclosed in any way without the prior written authorization of the Contract Administrator. The use and disclosure of the confidential information shall not apply to information which:

- (a) was known to the Bidder before receipt hereof; or
- (b) becomes publicly known other than through the Bidder; or
- (c) is disclosed pursuant to the requirements of a governmental authority or judicial order.

B4.2 The Bidder shall not make any statement of fact or opinion regarding any aspect of the Tender to the media or any member of the public without the prior written authorization of the Contract Administrator.

B5. ADDENDA

B5.1 The Contract Administrator may, at any time prior to the Submission deadline, issue addenda correcting errors, discrepancies or omissions in the Tender, or clarifying the meaning or intent of any provision therein.

- B5.2 The Contract Administrator will issue each addendum at least two (2) Business Days prior to the Submission Deadline, or provide at least two (2) Business Days by extending the Submission Deadline.
- B5.3 Addenda will be available on the Bid Opportunities page at The City of Winnipeg, Corporate Finance, Materials Management Division website at <http://www.winnipeg.ca/matmgt/bidopp.asp>
- B5.4 The Bidder is responsible for ensuring that he/she has received all addenda and is advised to check the Materials Management Division website for addenda regularly and shortly before the Submission Deadline, as may be amended by addendum.
- B5.5 The Bidder shall acknowledge receipt of each addendum in Paragraph 8 of Form A: Bid. Failure to acknowledge receipt of an addendum may render a Bid non-responsive.
- B5.6 Notwithstanding B3, enquiries related to an Addendum may be directed to the Contract Administrator indicated in D6.

B6. SUBSTITUTES

- B6.1 The Work is based on the materials, equipment, methods and products specified in the Tender.
- B6.2 Substitutions shall not be allowed unless application has been made to and prior approval has been granted by the Contract Administrator in writing.
- B6.3 Requests for approval of a substitute will not be considered unless received in writing by the Contract Administrator at least seven (7) Business Days prior to the Submission Deadline.
- B6.4 The Bidder shall ensure that any and all requests for approval of a substitute:
- (a) provide sufficient information and details to enable the Contract Administrator to determine the acceptability of the material, equipment, method or product as either an approved equal or alternative;
 - (b) identify any and all changes required in the applicable Work, and all changes to any other Work, which would become necessary to accommodate the substitute;
 - (c) identify any anticipated cost or time savings that may be associated with the substitute;
 - (d) certify that, in the case of a request for approval as an approved equal, the substitute will fully perform the functions called for by the general design, be of equal or superior substance to that specified, is suited to the same use and capable of performing the same function as that specified and can be incorporated into the Work, strictly in accordance with the Contract;
 - (e) certify that, in the case of a request for approval as an approved alternative, the substitute will adequately perform the functions called for by the general design, be similar in substance to that specified, is suited to the same use and capable of performing the same function as that specified and can be incorporated into the Work, strictly in accordance with the Contract.
- B6.5 The Contract Administrator, after assessing the request for approval of a substitute, may in his/her sole discretion grant approval for the use of a substitute as an "approved equal" or as an "approved alternative", or may refuse to grant approval of the substitute.
- B6.6 The Contract Administrator will provide a response in writing, at least two (2) Business Days prior to the Submission Deadline, to the Bidder who requested approval of the substitute.
- B6.6.1 The Contract Administrator will issue an Addendum, disclosing the approved materials, equipment, methods and products to all potential Bidders. The Bidder requesting and obtaining the approval of a substitute shall be responsible for disseminating information regarding the approval to any person or persons he/she wishes to inform.

- B6.7 If the Contract Administrator approves a substitute as an “approved equal”, any Bidder may use the approved equal in place of the specified item.
- B6.8 If the Contract Administrator approves a substitute as an “approved alternative”, any Bidder bidding that approved alternative may base his/her Total Bid Price upon the specified item but may also indicate an alternative price based upon the approved alternative. Such alternatives will be evaluated in accordance with B16.
- B6.9 No later claim by the Contractor for an addition to the price(s) because of any other changes in the Work necessitated by the use of an approved equal or an approved alternative will be considered.

B7. BID SUBMISSION

- B7.1 The Bid shall consist of the following components:
- (a) Form A: Bid; and
 - (b) Form B: Prices.
- B7.2 Further to B7.1, the Bidder should include the written correspondence from the Contract Administrator approving a substitute in accordance with B6.
- B7.3 All components of the Bid shall be fully completed or provided, and submitted by the Bidder no later than the Submission Deadline, with all required entries made clearly and completely.
- B7.4 The Bid Submission may be submitted by mail, courier or personal delivery, or by facsimile transmission.
- B7.5 If the Bid Submission is submitted by mail, courier or personal delivery, it shall be enclosed and sealed in an envelope clearly marked with the Tender number and the Bidder's name and address, and shall be submitted to:
- The City of Winnipeg
Corporate Finance Department
Materials Management Division
185 King Street, Main Floor
Winnipeg MB R3B 1J1
- B7.5.1 Samples or other components of the Bid Submission which cannot reasonably be enclosed in the envelope may be packaged separately, but shall be clearly marked with the Tender number, the Bidder's name and address, and an indication that the contents are part of the Bidder's Bid Submission.
- B7.6 If the Bid Submission is submitted by facsimile transmission, it shall be submitted to 204- 949-1178.
- B7.6.1 The Bidder is advised that the City cannot take responsibility for the availability of the facsimile machine at any time or guarantee the successful receipt of a faxed Bid Submission.
- B7.7 Bidders are advised not to include any information/literature except as requested in accordance with B7.1.
- B7.8 Bidders are advised that inclusion of terms and conditions inconsistent with the Tender document, including the General Conditions, will be evaluated in accordance with B16.1(a).
- B7.9 Bids submitted by internet electronic mail (e-mail) will not be accepted.

B8. BID

- B8.1 The Bidder shall complete Form A: Bid, making all required entries.

- B8.2 Paragraph 2 of Form A: Bid shall be completed in accordance with the following requirements:
- (a) if the Bidder is a sole proprietor carrying on business in his/her own name, his/her name shall be inserted;
 - (b) if the Bidder is a partnership, the full name of the partnership shall be inserted;
 - (c) if the Bidder is a corporation, the full name of the corporation shall be inserted;
 - (d) if the Bidder is carrying on business under a name other than his/her own, the business name and the name of every partner or corporation who is the owner of such business name shall be inserted.
- B8.2.1 If a Bid is submitted jointly by two or more persons, each and all such persons shall identify themselves in accordance with B8.2.
- B8.3 In Paragraph 3 of Form A: Bid, the Bidder shall identify a contact person who is authorized to represent the Bidder for purposes of the Bid.
- B8.4 Paragraph 11 of Form A: Bid shall be signed in accordance with the following requirements:
- (a) if the Bidder is a sole proprietor carrying on business in his/her own name, it shall be signed by the Bidder;
 - (b) if the Bidder is a partnership, it shall be signed by the partner or partners who have authority to sign for the partnership;
 - (c) if the Bidder is a corporation, it shall be signed by its duly authorized officer or officers;
 - (d) if the Bidder is carrying on business under a name other than his/her own, it shall be signed by the registered owner of the business name, or by the registered owner's authorized officials if the owner is a partnership or a corporation.
- B8.4.1 The name and official capacity of all individuals signing Form A: Bid should be printed below such signatures.
- B8.5 If a Bid is submitted jointly by two or more persons, the word "Bidder" shall mean each and all such persons, and the undertakings, covenants and obligations of such joint Bidders in the Bid and the Contract, when awarded, shall be both joint and several.

B9. PRICES

- B9.1 The Bidder shall state a price in Canadian funds for each item of the Work identified on Form B: Prices.
- B9.1.1 Prices on Form B: Prices shall include:
- (a) duty;
 - (b) freight and cartage;
 - (c) Provincial and Federal taxes [except the Goods and Services Tax (GST) and Manitoba Retail Sales Tax (MRST, also known as PST), which shall be extra where applicable] and all charges governmental or otherwise paid;
 - (d) profit and all compensation which shall be due to the Contractor for the Work and all risks and contingencies connected therewith.
- B9.2 The quantities listed on Form B: Prices are to be considered approximate only. The City will use said quantities for the purpose of comparing Bids.
- B9.3 The quantities for which payment will be made to the Contractor are to be determined by the Work actually performed and completed by the Contractor, to be measured as specified in the applicable Specifications.

B10. DISCLOSURE

B10.1 Various Persons provided information or services with respect to this Work. In the City's opinion, this relationship or association does not create a conflict of interest because of this full disclosure. Where applicable, additional material available as a result of contact with these Persons is listed below.

B10.2 The Persons are:

- (a) Peerless Garments Ltd.: specifications.

B11. CONFLICT OF INTEREST AND GOOD FAITH

B11.1 Bidders, by responding to this Tender, declare that no Conflict of Interest currently exists, or is reasonably expected to exist in the future.

B11.2 Conflict of Interest means any situation or circumstance where a Bidder or employee of the Bidder proposed for the Work has:

- (a) other commitments;
- (b) relationships;
- (c) financial interests; or
- (d) involvement in ongoing litigation;

that could or would be seen to:

- (i) exercise an improper influence over the objective, unbiased and impartial exercise of the independent judgment of the City with respect to the evaluation of Bids or award of the Contract; or
- (ii) compromise, impair or be incompatible with the effective performance of a Bidder's obligations under the Contract;
- (e) has contractual or other obligations to the City that could or would be seen to have been compromised or impaired as a result of its participation in the Tender process or the Work; or
- (f) has knowledge of confidential information (other than confidential information disclosed by the City in the normal course of the Tender process) of strategic and/or material relevance to the Tender process or to the Work that is not available to other bidders and that could or would be seen to give that Bidder an unfair competitive advantage.

B11.3 In connection with its Bid, each entity identified in B11.2 shall:

- (a) avoid any perceived, potential or actual Conflict of Interest in relation to the procurement process and the Work;
- (b) upon discovering any perceived, potential or actual Conflict of Interest at any time during the Tender process, promptly disclose a detailed description of the Conflict of Interest to the City in a written statement to the Contract Administrator; and
- (c) provide the City with the proposed means to avoid or mitigate, to the greatest extent practicable, any perceived, potential or actual Conflict of Interest and shall submit any additional information to the City that the City considers necessary to properly assess the perceived, potential or actual Conflict of Interest.

B11.4 Without limiting B11.3, the City may, in its sole discretion, waive any and all perceived, potential or actual Conflicts of Interest. The City's waiver may be based upon such terms and conditions as the City, in its sole discretion, requires to satisfy itself that the Conflict of Interest has been appropriately avoided or mitigated, including requiring the Bidder to put into place such policies, procedures, measures and other safeguards as may be required by and be acceptable to the City, in its sole discretion, to avoid or mitigate the impact of such Conflict of Interest.

- B11.5 Without limiting B11.3, and in addition to all contractual or other rights or rights at law or in equity or legislation that may be available to the City, the City may, in its sole discretion:
- (a) disqualify a Bidder that fails to disclose a perceived, potential or actual Conflict of Interest of the Bidder or any of its employees proposed for the Work;
 - (b) require the removal or replacement of any employees proposed for the Work that has a perceived, actual or potential Conflict of Interest that the City, in its sole discretion, determines cannot be avoided or mitigated;
 - (c) disqualify a Bidder or employees proposed for the Work that fails to comply with any requirements prescribed by the City pursuant to B11.4 to avoid or mitigate a Conflict of Interest; and
 - (d) disqualify a Bidder if the Bidder, or one of its employees proposed for the Work, has a perceived, potential or actual Conflict of Interest that, in the City's sole discretion, cannot be avoided or mitigated, or otherwise resolved.
- B11.6 The final determination of whether a perceived, potential or actual Conflict of Interest exists shall be made by the City, in its sole discretion.

B12. QUALIFICATION

- B12.1 The Bidder shall:
- (a) undertake to be in good standing under The Corporations Act (Manitoba), or properly registered under The Business Names Registration Act (Manitoba), or otherwise properly registered, licensed or permitted by law to carry on business in Manitoba, or if the Bidder does not carry on business in Manitoba, in the jurisdiction where the Bidder does carry on business; and
 - (b) be financially capable of carrying out the terms of the Contract; and
 - (c) have all the necessary experience, capital, organization, and equipment to perform the Work in strict accordance with the terms and provisions of the Contract.
- B12.2 The Bidder and any proposed Subcontractor (for the portion of the Work proposed to be subcontracted to them) shall:
- (a) be responsible and not be suspended, debarred or in default of any obligations to the City. A list of suspended or debarred individuals and companies is available on the Information Connection page at The City of Winnipeg, Corporate Finance, Materials Management Division website at <https://winnipeg.ca/finance/findata/matmgt/listing/debar.pdf>
- B12.3 The Bidder and/or any proposed Subcontractor (for the portion of the Work proposed to be subcontracted to them) shall:
- (a) have successfully carried out work similar in nature, scope and value to the Work; and
 - (b) be fully capable of performing the Work required to be in strict accordance with the terms and provisions of the Contract; and
 - (c) have a written workplace safety and health program, if required, pursuant to The Workplace Safety and Health Act (Manitoba).
- B12.4 The Bidder shall submit, within three (3) Business Days of a request by the Contract Administrator, proof satisfactory to the Contract Administrator of the qualifications of the Bidder and of any proposed Subcontractor.

Representative Samples

- B12.5 The Bidder shall provide and submit, within (15) Business days of a request by the Contract Administrator:
- (a) Representative Samples of Goods offered, and as described in E2 as follows:

- (i) One (1) sample of Bus Operator Jacket - Item No. 1, size Large as specified in E2.4, which shall also include:
 - (i) One (1) additional metre of shell fabric, and one (1) additional metre of lining fabric; and
 - (ii) Laboratory analysis of the materials showing complete test results in accordance with Table 1 and Table 2. The test results shall detail the technical requirements.
 - ◆ Testing must be performed by an independent accredited laboratory establishment, and must be in accordance with the test methods detailed in the Requirement.
 - ◆ The laboratory report and test results must be dated after the Bid Opportunity posting date.
- (ii) One (1) sample of Bus Operator Fleece Item No. 2, size Large as specified in E2.5.

- B12.5.1 The quality of the Representative Samples received from the Bidder must meet the specifications stated in E2 through E9;
- B12.5.2 The size dimensions of the Representative Sample must meet the dimensions stated in the Measurement Chart stated in E10.
- B12.5.3 Fabric of the Representative Sample must meet the specifications in Table 1 and Table 2;
- B12.5.4 The manufacturer name and part number must be visible on each Representative Sample provided.
- B12.6 The Bidder shall provide, on the request of the Contract Administrator, full access to any of the Bidder's equipment and facilities to confirm, to the Contract Administrator's satisfaction, that the Bidder's equipment and facilities are adequate to perform the Work.

B13. OPENING OF BIDS AND RELEASE OF INFORMATION

- B13.1 Bids will not be opened publicly.
- B13.2 Following the Submission Deadline, the names of the Bidders and their Total Bid Prices (unevaluated, and pending review and verification of conformance with requirements or evaluated prices) will be available on the Closed Bid Opportunities (or Public/Posted Opening & Award Results) page at The City of Winnipeg, Corporate Finance, Materials Management Division website at <http://www.winnipeg.ca/matmgt>
- B13.3 After award of Contract, the name(s) of the successful Bidder(s), their address(es) and the Contract amount(s) will be available on the Closed Bid Opportunities (or Public/Posted Opening & Award Results) page at The City of Winnipeg, Corporate Finance, Materials Management Division website at <http://www.winnipeg.ca/matmgt>
- B13.4 The Bidder is advised that any information contained in any Bid may be released if required by The Freedom of Information and Protection of Privacy Act (Manitoba), by other authorities having jurisdiction, or by law or by City policy or procedures (which may include access by members of City Council).
 - B13.4.1 To the extent permitted, the City shall treat as confidential information, those aspects of a Bid Submission identified by the Bidder as such in accordance with and by reference to Part 2, Section 17 or Section 18 or Section 26 of The Freedom of Information and Protection of Privacy Act (Manitoba), as amended.

B14. IRREVOCABLE BID

- B14.1 The Bid(s) submitted by the Bidder shall be irrevocable for the time period specified in Paragraph 9 of Form A: Bid.

B14.2 The acceptance by the City of any Bid shall not release the Bids of the next two lowest evaluated responsive Bidders and these Bidders shall be bound by their Bids on such Work for the time period specified in Paragraph 9 of Form A: Bid.

B15. WITHDRAWAL OF BIDS

B15.1 A Bidder may withdraw his/her Bid without penalty by giving written notice to the Manager of Materials at any time prior to the Submission Deadline.

B15.1.1 Notwithstanding C21, the time and date of receipt of any notice withdrawing a Bid shall be the time and date of receipt as determined by the Manager of Materials.

B15.1.2 The City will assume that any one of the contact persons named in Paragraph 3 of Form A: Bid or the Bidder's authorized representatives named in Paragraph 11 of Form A: Bid, and only such person, has authority to give notice of withdrawal.

B15.1.3 If a Bidder gives notice of withdrawal prior to the Submission Deadline, the Manager of Materials will:

- (a) retain the Bid until after the Submission Deadline has elapsed;
- (b) open the Bid to identify the contact person named in Paragraph 3 of Form A: Bid and the Bidder's authorized representatives named in Paragraph 11 of Form A: Bid; and
- (c) if the notice has been given by any one of the persons specified in B15.1.3(b), declare the Bid withdrawn.

B15.2 A Bidder who withdraws his/her Bid after the Submission Deadline but before his/her Bid has been released or has lapsed as provided for in B14.2 shall be liable for such damages as are imposed upon the Bidder by law and subject to such sanctions as the Chief Administrative Officer considers appropriate in the circumstances. The City, in such event, shall be entitled to all rights and remedies available to it at law.

B16. EVALUATION OF BIDS

B16.1 Award of the Contract shall be based on the following bid evaluation criteria:

- (a) compliance by the Bidder with the requirements of the Tender, or acceptable deviation therefrom (pass/fail);
- (b) qualifications of the Bidder and the Subcontractors, if any, pursuant to B12 (pass/fail);
- (c) Total Bid Price;
- (d) economic analysis of any approved alternative pursuant to B6.

B16.2 Further to B16.1(a), the Award Authority may reject a Bid as being non-responsive if the Bid Submission is incomplete, obscure or conditional, or contains additions, deletions, alterations or other irregularities. The Award Authority may reject all or any part of any Bid, or waive technical requirements or minor informalities or irregularities if the interests of the City so require.

B16.3 Further to B16.1(b), the Award Authority shall reject any Bid submitted by a Bidder who does not demonstrate, in his/her Bid or in other information required to be submitted, that he/she is qualified.

B16.4 Further to B16.1(c), the Total Bid Price shall be the sum of the quantities multiplied by the unit prices for each item shown on Form B: Prices.

B16.5 This Contract will be awarded as a whole.

B17. AWARD OF CONTRACT

B17.1 The City will give notice of the award of the Contract or will give notice that no award will be made.

- B17.2 The City will have no obligation to award a Contract to a Bidder, even though one or all of the Bidders are determined to be qualified, and the Bids are determined to be responsive.
- B17.2.1 Without limiting the generality of B17.2, the City will have no obligation to award a Contract where:
- (a) the prices exceed the available City funds for the Work;
 - (b) the prices are materially in excess of the prices received for similar work in the past;
 - (c) the prices are materially in excess of the City's cost to perform the Work, or a significant portion thereof, with its own forces;
 - (d) only one Bid is received; or
 - (e) in the judgment of the Award Authority, the interests of the City would best be served by not awarding a Contract.
- B17.3 Where an award of Contract is made by the City, the award shall be made to the qualified Bidder submitting the lowest evaluated responsive Bid, in accordance with B16.
- B17.3.1 Following the award of contract, a Bidder will be provided with information related to the evaluation of his/her Bid upon written request to the Contract Administrator.
- B17.4 Notwithstanding C4, the City may issue a purchase order to the successful Bidder in lieu of the execution of a Contract.
- B17.5 The Contract Documents, as defined in C1.1(n)(ii), in their entirety shall be deemed to be incorporated in and to form a part of the purchase order notwithstanding that they are not necessarily attached to or accompany said purchase order.

PART C - GENERAL CONDITIONS

C0. GENERAL CONDITIONS

- C0.1 The *General Conditions for the Supply of Goods* (Revision 2019-01-15) are applicable to the Work of the Contract.
- C0.1.1 The *General Conditions for the Supply of Goods* are available on the Information Connection page at The City of Winnipeg, Corporate Finance, Materials Management Division website at http://www.winnipeg.ca/matmgt/gen_cond.stm
- C0.2 A reference in the Tender to a section, clause or subclause with the prefix "**C**" designates a section, clause or subclause in the *General Conditions for Supply of Goods*.

PART D - SUPPLEMENTAL CONDITIONS

GENERAL

D1. GENERAL CONDITIONS

D1.1 In addition to the *General Conditions for the Supply of Goods*, these Supplemental Conditions are applicable to the Work of the Contract.

D2. UNFAIR LABOUR PRACTICES

D2.1 Further to C3.2, the Contractor declares that in bidding for the work and in entering into this contract, he and his subcontractors conduct their respective business in accordance with established international codes as they relate to child and forced labour embodied in United Nations (UN) and International Labour Organization (ILO) conventions as ratified by Canada.

D2.2 The Contractor shall forfeit all claims under the Contract as well as refund to the City any monies paid to him, beyond his actual proven expenses for work done, if this declaration is shown to be false.

D3. SCOPE OF WORK

D3.1 The Work to be done under the Contract shall consist of supply and delivery of bus operator jackets for the period from February 1, 2020 until January 31, 2021, with the option of five (5) mutually agreed upon one (1) year extensions.

D3.1.1 The City may negotiate the extension option with the Contractor within ninety (90) Calendar Days prior to the expiry date of the Contract. The City shall incur no liability to the Contractor as a result of such negotiations.

D3.1.2 Changes resulting from such negotiations shall become effective on February 1st of the respective year. Changes to the Contract shall not be implemented by the Contractor without written approval by the Contract Administrator.

D3.2 The Work shall be done on an "as required" basis during the term of the Contract.

D3.2.1 The type and quantity of Work to be performed under this Contract shall be as authorized from time to time by the Contract Administrator and/or Users.

D3.2.2 Notwithstanding C7, the City shall have no obligation under the Contract to purchase any quantity of any item in excess of its actual operational requirements.

D4. COOPERATIVE PURCHASE

D4.1 The Contractor is advised that this is a cooperative purchase.

D4.2 The Contract Administrator may, from time to time during the term of the Contract, approve other public sector organizations and utilities, including but not limited to municipalities, universities, schools and hospitals, to be participants in the cooperative purchase.

D4.3 The Contract Administrator will notify the Contractor of a potential participant and provide a list of the delivery locations and estimated quantities.

D4.4 If any location of the potential participant is more than ten (10) kilometres beyond the boundaries of the City of Winnipeg, the Contractor shall, within fifteen (15) Calendar Days of the written notice, notify the Contract Administrator of the amount of any additional delivery charge for the location.

D4.5 If any additional delivery charges are identified by the Contractor, the potential participant may accept or decline to participate in the cooperative purchase.

- D4.6 The Contractor shall enter into a contract with each participant under the same terms and conditions as this Contract except:
- (a) supply under the contract shall not commence until the expiry or lawful termination of any other contract(s) binding the participant for the same goods;
 - (b) a participant may specify a duration of Contract shorter than the duration of this Contract;
 - (c) a participant may specify that only some items under this Contract and/or less than its total requirement for an item are to be supplied under its contract; and
 - (d) any additional delivery charge identified and accepted in accordance with clause D4.4 and D4.5 will apply.
- D4.7 Each participant will be responsible for the administration of its contract and the fulfilment of its obligations under its contract. The City shall not incur any liability arising from any such contract.
- D4.8 No participant shall have the right or authority to effect a change in the Contract, or of any other participant in this Contract.

D5. DEFINITIONS

- D5.1 When used in this Bid Opportunity:
- (a) "**Representative Samples**" means the samples submitted will be *exactly* what will be provided for the duration of the contract and must meet specifications.

D6. CONTRACT ADMINISTRATOR

- D6.1 The Contract Administrator is:
Ron Martin, SCMP.
Inventory Coordinator - Transit Stores.
Telephone No.: 204- 986-6864
Email Address: ronmartin@winnipeg.ca

D7. OWNERSHIP OF INFORMATION, CONFIDENTIALITY AND NON DISCLOSURE

- D7.1 The Contract, all deliverables produced or developed, and information provided to or acquired by the Contractor are the property of the City and shall not be appropriated for the Contractors own use, or for the use of any third party.
- D7.2 The Contractor shall not make any public announcements or press releases regarding the Contract, without the prior written authorization of the Contract Administrator.
- D7.3 The following shall be confidential and shall not be disclosed by the Contractor to the media or any member of the public without the prior written authorization of the Contract Administrator;
- (a) information provided to the Contractor by the City or acquired by the Contractor during the course of the Work;
 - (b) the Contract, all deliverables produced or developed; and
 - (c) any statement of fact or opinion regarding any aspect of the Contract.
- D7.4 A Contractor who violates any provision of D7 may be determined to be in breach of Contract.

D8. NOTICES

- D8.1 Notwithstanding C21.3, all notices of appeal to the Chief Administrative Officer shall be sent to the attention of the Chief Financial Officer.

SUBMISSIONS

D9. AUTHORITY TO CARRY ON BUSINESS

D9.1 The Contractor shall be in good standing under The Corporations Act (Manitoba), or properly registered under The Business Names Registration Act (Manitoba), or otherwise properly registered, licensed or permitted by law to carry on business in Manitoba, or if the Contractor does not carry on business in Manitoba, in the jurisdiction where the Contractor does carry on business, throughout the term of the Contract, and shall provide the Contract Administrator with evidence thereof upon request.

SCHEDULE OF WORK

D10. COMMENCEMENT

D10.1 The Contractor shall not commence any Work until he/she is in receipt of a notice of award from the City authorizing the commencement of the Work.

D10.2 The Contractor shall not commence any Work until:

- (a) the Contract Administrator has confirmed receipt and approval of:
 - (i) evidence of authority to carry on business specified in D9;
 - (ii) evidence of the workers compensation coverage specified in C6.16;
- (b) the Contractor has attended a meeting with the Contract Administrator, or the Contract Administrator has waived the requirement for a meeting.

D11. DELIVERY

D11.1 Goods shall be delivered on an "as required" basis during the term of the Contract, f.o.b. destination, freight prepaid, to:

Winnipeg Transit Stores
421 Osborne Street.
Winnipeg, Mb, R3L 2A2

D11.1.1 Goods shall be delivered within forty (40) Calendar Day(s) of the placing of an order.

D11.2 Initial start-up delivery shall be sixty (60) Business days from the date of award.

D11.3 After the initial start-up delivery stated in D11.2, Goods shall be delivered in accordance with D11.1.1.

D11.4 Goods shall be delivered between 7:00 a.m. and 2:00 p.m. on Business Days.

D11.5 The Contractor shall off-load goods as directed at the delivery location.

D12. LIQUIDATED DAMAGES

D12.1 If the Contractor fails to achieve delivery of the goods within the time specified in D11. Delivery the Contractor shall pay the City seventy-three dollars (\$73.00) per item per Working Day for each and every Working Day until the goods have been delivered.

D12.2 The amount specified for liquidated damages in D12.1 is based on a genuine pre-estimate of the City's damages in the event that the Contractor does not achieve delivery by the day fixed herein for same.

D12.3 The City may reduce any payment to the Contractor by the amount of any liquidated damages assessed.

D13. ORDERS

D13.1 The Contractor shall provide a local Winnipeg telephone number or a toll-free telephone number at which orders for delivery may be placed.

D14. RECORDS

D14.1 The Contractor shall keep detailed records of the goods supplied under the Contract.

D14.2 The Contractor shall record, as a minimum, for each item listed on Form B: Prices:

- (a) user name(s) and addresses;
- (b) order date(s);
- (c) delivery date(s); and
- (d) description and quantity of goods supplied.

D14.3 The Contractor shall provide the Contract Administrator with a copy of the records for each quarter year within fifteen (15) Calendar Days of a request of the Contract Administrator.

MEASUREMENT AND PAYMENT

D15. INVOICES

D15.1 Further to C10, the Contractor shall submit an invoice for each order delivered to:

The City of Winnipeg
Corporate Finance - Accounts Payable
4th Floor, Administration Building, 510 Main Street
Winnipeg MB R3B 1B9
Facsimile No.: 204- 949-0864
Email: CityWpgAP@winnipeg.ca

D15.2 Invoices must clearly indicate, as a minimum:

- (a) the City's purchase order number;
- (b) date of delivery;
- (c) delivery address;
- (d) type and quantity of goods delivered;
- (e) the amount payable with GST, MRST, and any applicable environmental handling charges/fees identified and shown as separate amounts; and
- (f) the Contractor's GST registration number.

D15.3 The City will bear no responsibility for delays in approval of invoices which are improperly submitted.

D15.4 **Bid Submissions must not be submitted to the above facsimile numbers. Bids must be submitted in accordance with B7.**

D16. PAYMENT

D16.1 Further to C10, payment shall be in Canadian funds net thirty (30) Calendar Days after receipt and approval of the Contractor's invoice.

D16.2 Further to C10, the City may at its option pay the Contractor by direct deposit to the Contractor's banking institution.

WARRANTY

D17. WARRANTY

D17.1 Warranty is as stated in C11.

PART E - SPECIFICATIONS

GENERAL

E1. APPLICABLE SPECIFICATIONS

- E1.1 These Specifications shall apply to the Work.
- E1.2 Bidders are reminded that requests for approval of substitutes as an approved equal or an approved alternative shall be made in accordance with B6. In every instance where a brand name or design specification is used, the City will also consider approved equals and/or approved alternatives in accordance with B6.

E2. GOODS

- E2.1 The Contractor shall supply and deliver bus operator jackets in accordance with the requirements hereinafter specified.
- E2.2 Winnipeg Transit will supply all shoulder flashes. The Contractor is responsible for sewing the shoulder flashes onto the garment.
- E2.3 All heat sealed reflective tape and Transit logo shall be silver in color.
- E2.4 Item No. 1 - Bus Operator Jacket shall be as follows:

(a) All Season Outerwear System – herein identified as Outer Shell

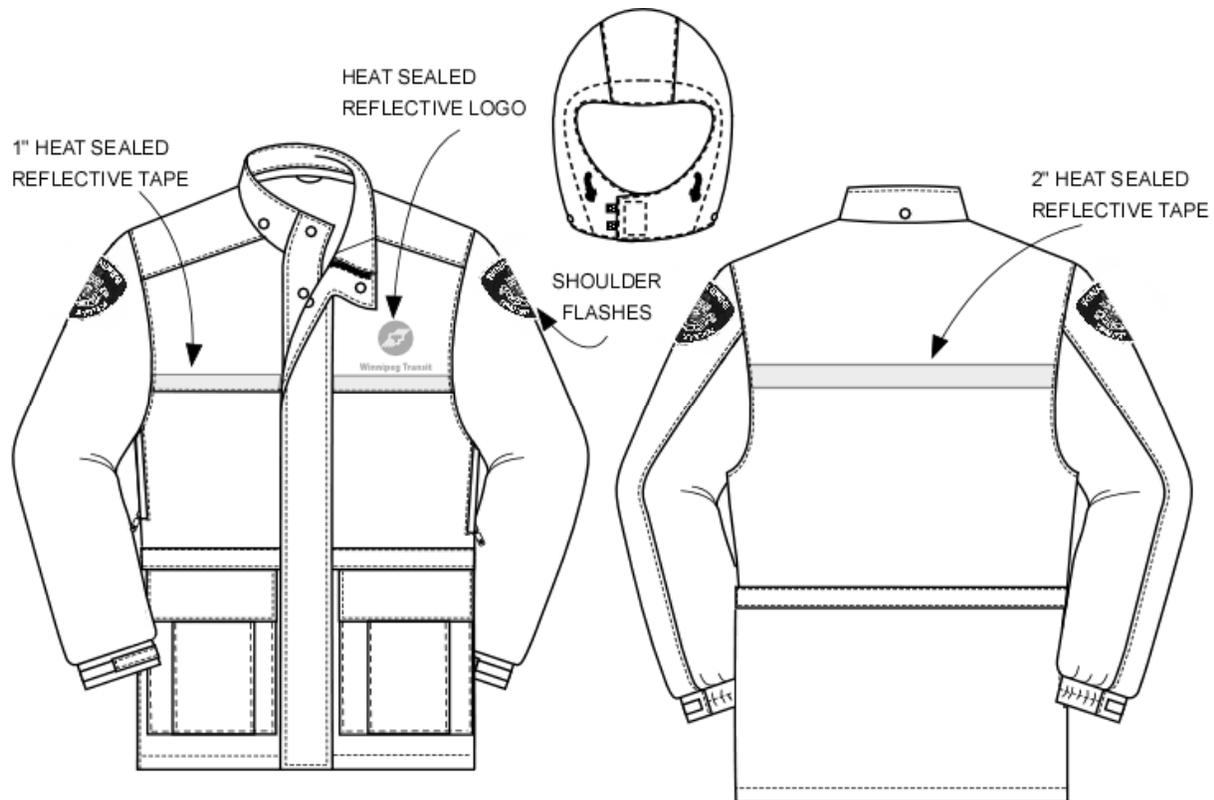

- E2.4.1 Outer Shell shall be an All Season 3-in-1 instructor length parka and shall include the following:
- (i) Double fly front over two way slide fasteners;

- (ii) Heat set reflective tape on front and back yokes and centre hood;
- (iii) Reflective logo on front chest;
- (iv) Set in sleeves with adjustable cuffs;
- (v) Underarm vents with slide fastener;
- (vi) Large front cargo pockets with hand warmer pockets;
- (vii) Shock cord at hem and waist channel;
- (viii) Dome off hood;
- (ix) Pen holder under front fly;
- (x) Hanger loop in neck seam;
- (xi) Zip out liner;
- (xii) Shell seams are sealed with compatible tape;
- (xiii) Shell: 100% Supplex nylon with a waterproof breathable polyurethane coating;
- (xiv) Lining: 100% nylon.

(b) Zip-out Liner with Set in Sleeves – herein identified as Inner Shell

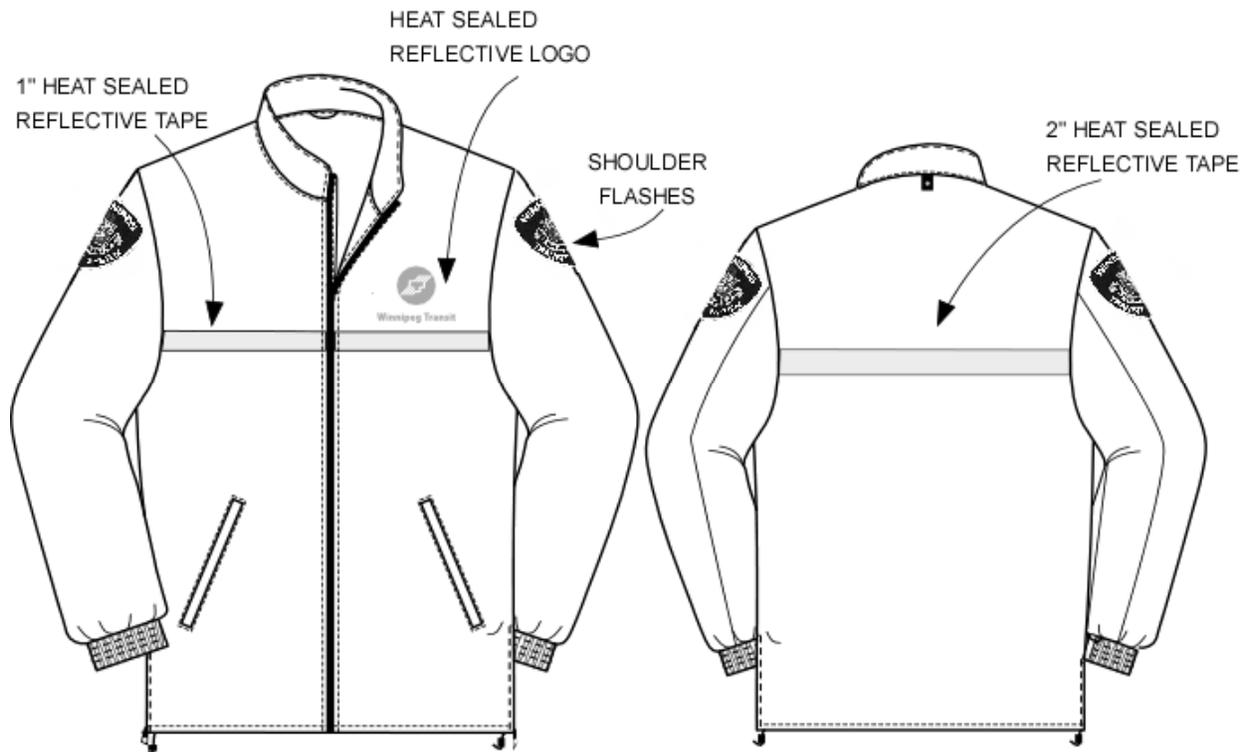

E2.4.2

Inner Shell shall include the following:

- (ii) Zip out jacket with quilt lining;
- (iii) Set in sleeve with elasticized cuff;
- (iv) Heat set reflective on the front and back yokes;
- (v) Welt pockets over coil zipper closure;
- (vi) Stand collar;
- (vii) Front slide fastener with inside storm fly;
- (viii) Side zips at hem;
- (ix) Hanger loop in neck seam;
- (x) Shell: 100% Supplex micro coated nylon;
- (xi) Lining: 100 % downproof Spinnaker nylon 85g/m2 ;

- (xii) 100% polyester interlining: before being layered has a CLO value of 540.

E2.5 Item No. 2 – Bus Operator Fleece shall be as follows:

(a) Soft Shell Fleece Garment with Zip-off Sleeve – herein identified as Soft Shell Fleece

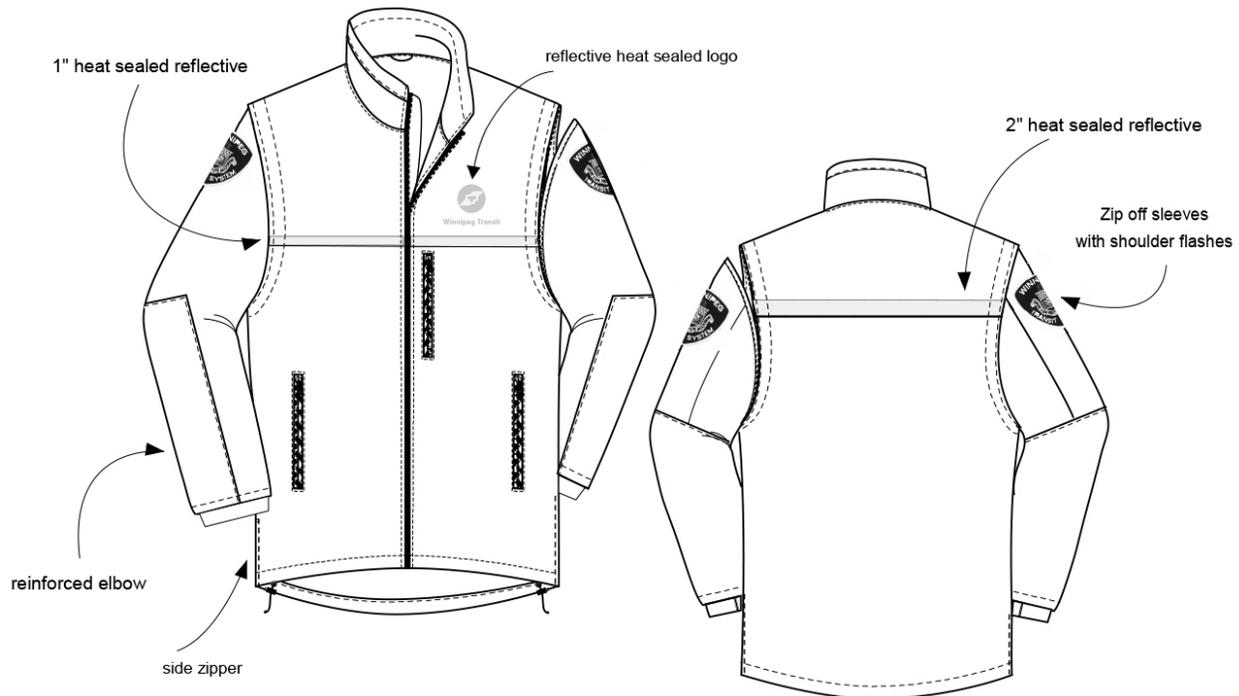

E2.5.1 Soft shell fleece jacket with nylon elbow, yoke and collar shall include the following:

- (i) Zip off sleeve with nylon knit storm cuff;
- (ii) Heat set reflective on the front and back yokes;
- (iii) Zipper pockets and chest zip pocket;
- (iv) Stand collar with fleece liner;
- (v) Front slide fastener with inside storm fly;
- (vi) Side zips at bottom hem;
- (vii) Shock cord at hem;
- (viii) Hanger loop in neck seam;
- (ix) Shell: 100% polyester fleece bonded mesh (305g/m²), anti pill surface;
- (x) Trim: 100% nylon.

E3. COMPONENTS

E3.1 Shall have the following:

- (a) Outer Shell:
 - (i) Jet Black: 100% Supplex nylon with PU coating, waterproof breathable. Refer to Table 1;
 - (ii) Seam Tape: Commercially available 1" tape, must be compatible with the shell material; and
 - (iii) Lining: Jet Black: 100% nylon.
- (b) Inner Shell:

- (i) Jet Black: 100 % nylon: Refer to Table 2; and
 - (ii) Interlining: 100% Polyester with a CLO value of no less than 540 before layering.
- (c) Soft Shell Fleece:
- (i) Jet Black: 100% Polyester fleece bonded mesh (305g/m2(meter squared));
 - (ii) Anti-pill fleece.

E4. SLIDE FASTENERS

E4.1 Shall have the following:

- (a) Outer Shell:
- (i) Jet Black;
 - (ii) Front - Class III Type 9 Plastic Molded, YKK two-way open end #5 Vislon separating;
 - (iii) Inner Front - Class III Type 10 Plastic Molded, YKK two-way open end reversible #5 Vislon separating; and
 - (iv) Pit zip - Class II Type 11 Monofilament with PU coating YKK two-way closed end #5 coil closed.
- (b) Inner Shell:
- (i) Jet Black;
 - (ii) Front of garment - Class III Type 10 Plastic Molded YKK two-way open end reversible #5 Vislon separating;
 - (iii) Pocket zip - Class III Type 1 Monofilament YKK one-way #5 coil closed end; and
 - (iv) Side zip - Class III Type 1 Monofilament. YKK one-way #5 coil non separating open end.
- (c) Soft Shell Fleece:
- (i) Jet Black;
 - (ii) Front of garment - Class III Type 9 Plastic Molded YKK two-way open end #5 Vislon separating;
 - (iii) Pocket zip - Class III Type 1 Plastic Molded YKK one-way #5 Vislon non separating open end; and
 - (iv) Arm hole - Class III Type 4 Monofilament YKK one-way #5 coil open end separating.

E5. TRIM COMPONENTS

E5.1 All garments shall have the following:

- (a) Thread: Color match material:
- (i) Seaming: Spun Polyester Tex 45;
 - (ii) Serging: Spun Polyester Tex 27.
- (b) Reflective components:
- (i) Color – silver;
 - (ii) Heat sealed reflective tape 2" across back yoke set about 5 ¾" above underarm point, and 1" wide at front yokes set ½" above seam;
 - (iii) Heat sealed Winnipeg Transit Logo centered on left front yoke ½" above reflective. Must meet CSA standard Z96-02.
- (c) Hook and Loop Fastener Tape:
- (i) Class I Type II Hook and Loop: Color: Black;
 - (ii) Woven nylon with high life cycle. Combined hook and loop should have no less than 8 P.S.I. length wise tear strength. Initial peel strength should not be less than 1

P.I.W. and after 1000 cycles should not be less 0.5 P.I.W with a minimum shear of 4 P.S.I. 1" at pocket closure and cuff.

- (d) Elastic cord: Color: Jet Black:
 - (i) Commercially available round elastic shock cord 3.5mm used at hem and waist. Must not exceed 2" from channel on each side.
- (e) Draw cord locks: Color - Jet Black:
 - (i) Commercially available, flat type, black acetyl with non corrosive metal spring and attachment slot.
- (f) Label : Color - White:
 - (i) Label must have washing instructions and fibre content;
 - (ii) Label should have line for employee id. Set label on inside chest pocket.
- (g) Eyelets: Color - Jet Black:
 - (i) Black oxidized finish spur eyelets size 3/16".
- (h) Snap Fasteners: Color - Jet Black:
 - (i) Black oxidized finish with a phosphorous bronze spring.
- (i) Elastic:
 - (i) 2" commercially available preshrunk, knitted polyester lycra, with an elongation of 125%.
- (j) Gross Grain Tape:
 - (i) ¾" gross grain tape used at cuff and neckline to hold liner in place.

E6. CUTTING

- E6.1 All parts of each jacket shall be cut from the same fabric dye lot, in the direction of the warp. The specified materials shall be cut and used in accordance with the best commercial standards and practices.

E7. SEWING

- E7.1 Stitching shall be lock stitch Type 301 or lock chain stitch Type 401 and having between 8 and 10 stitches per inch. Ends of all seams and stitching and any breaks in thread shall be securely backstitched. Stitching shall present a regular even appearance without fabric pucker and shall be free from skips, faulty tension or other malfunctions.

E8. SHOULDER FLASHES

- E8.3 Shoulder flashes will be supplied by Winnipeg Transit and will be sewn on by the Contractor.

E9. CONSTRUCTION

- E9.1 Outer Shell:
 - (a) **Front.** Each front shall have a large patch pocket with a side hand warmer pocket lined with fleece. The pockets shall have an envelope fold closure with a pocket flap. The flap and loop closure;

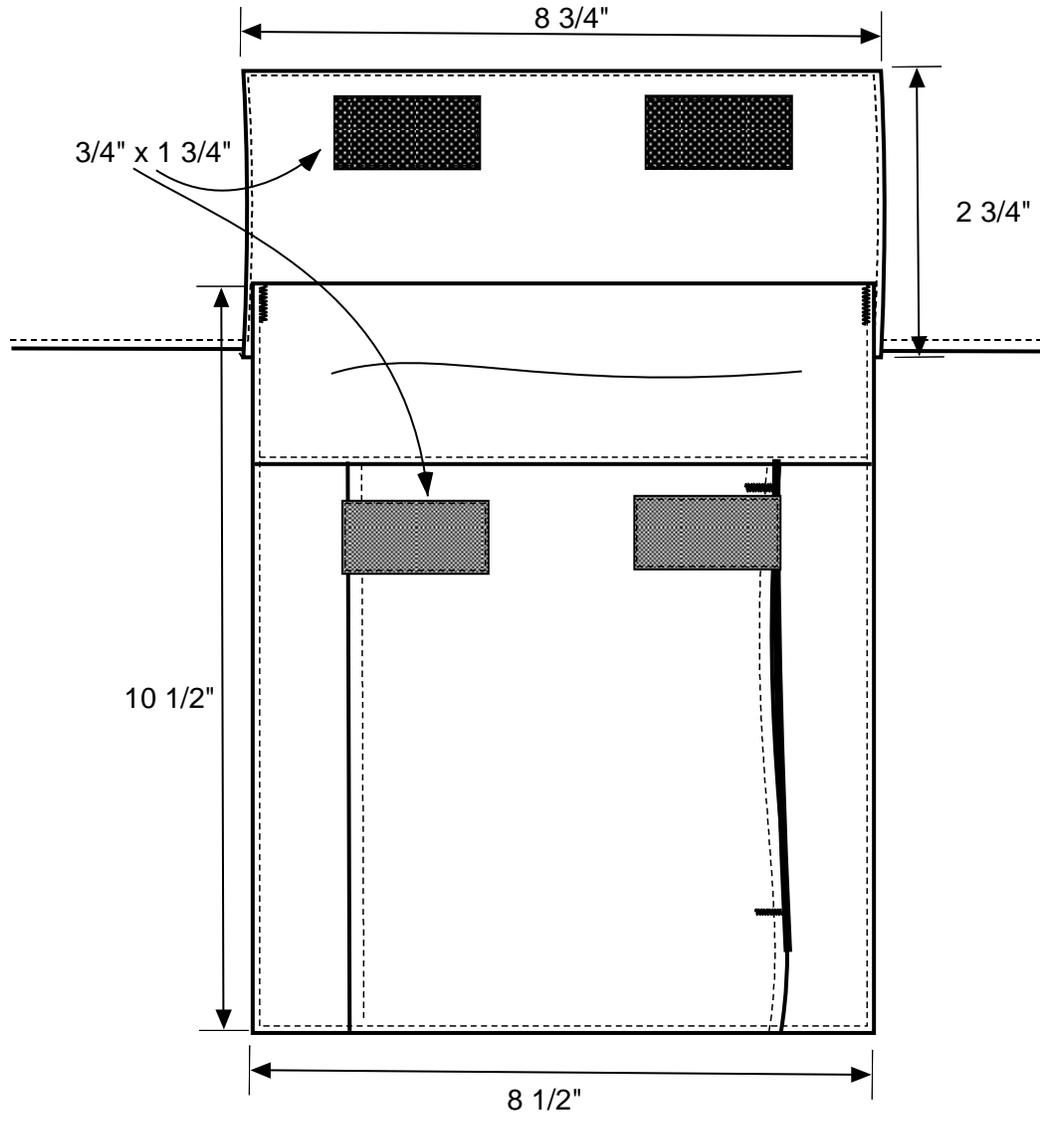

- (b) There shall be a front yoke with 1" reflective tape heat set 1/2" above the yoke seam and a Winnipeg Transit heat sealed label will be set on the left front yoke 2" above the seam line;

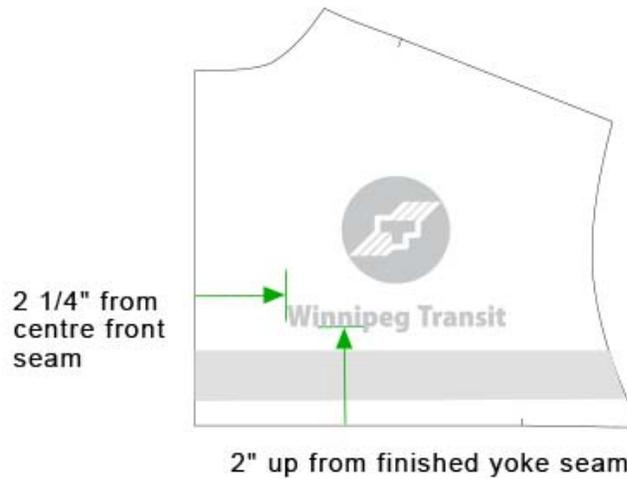

1" reflective set 1/2" above finished yoke seam

Size of Reflective Logo

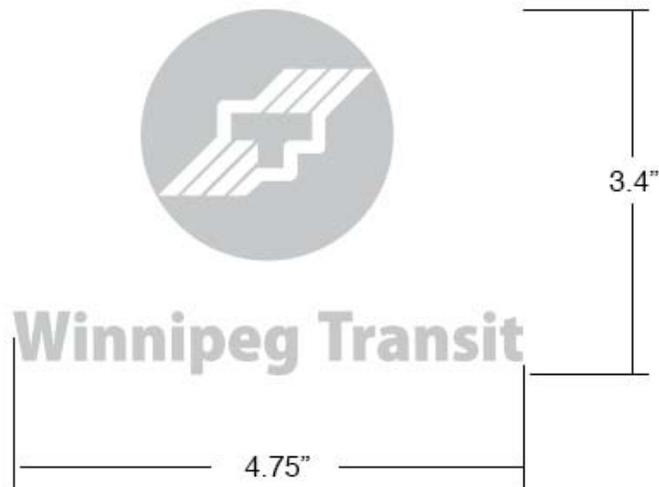

note illustrations are not to scale

- (c) There shall be a YKK #5 Vislon two way separating zipper set along the front closure. The zipper shall be covered by a double fly system that fastens with six evenly spaced hidden domes. A pencil pocket is set along the inside of the left fly seam;
- (d) There will be a second reversible zipper set along the inside of the outer zipper to attach the inner jacket to the outer jacket;

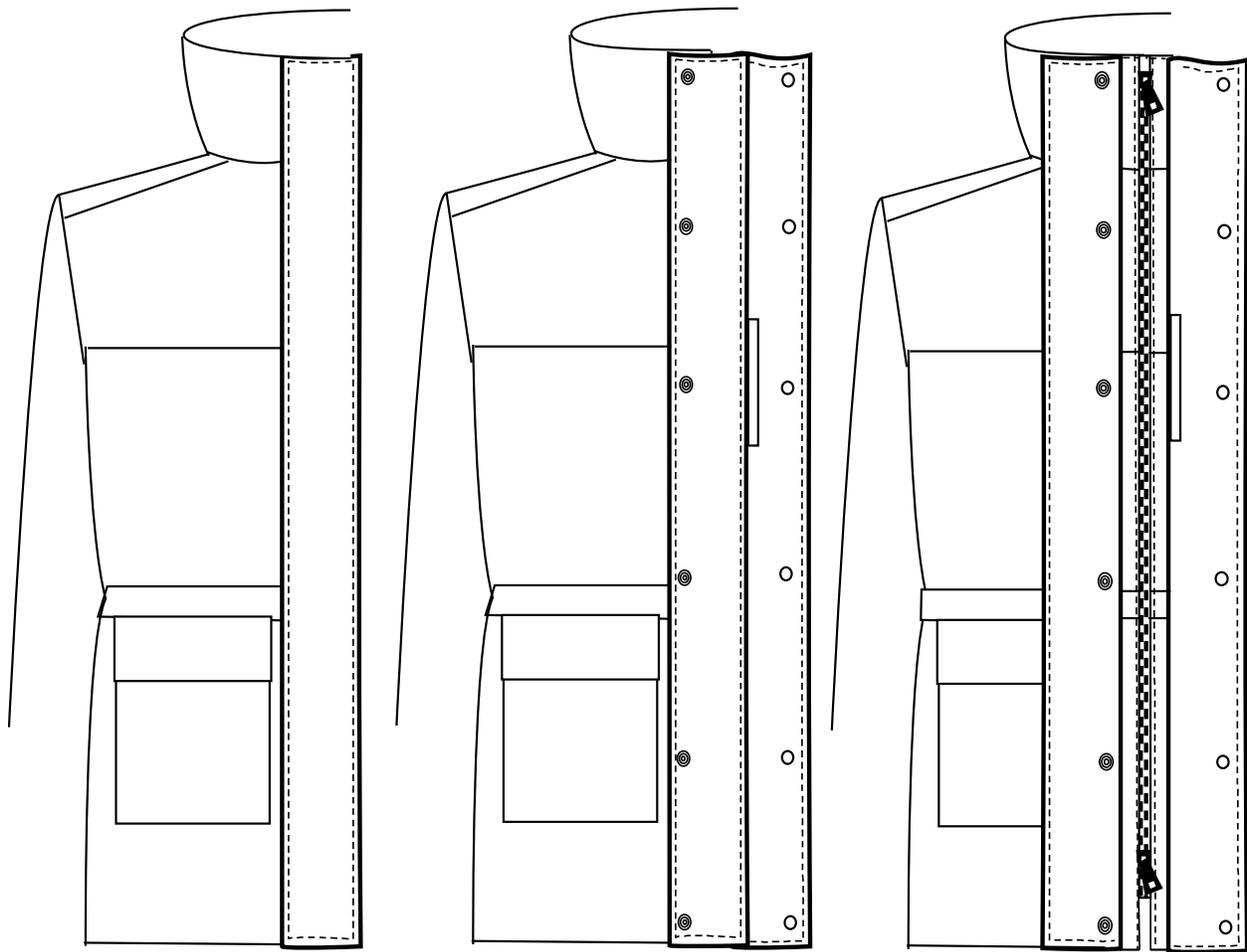

closed fly

left fly open

both right and left
open

- (e) The one piece back shall have 2" reflective sewn across the upper back about 6" down from centre neck seam;
- (f) There shall be a 1 ½" high waist channel that runs the circumference of the outer shell. A shock cord drawstring will be fed through an eyelet at the lining waist so that the channel can be adjusted on the inside of the garment. The ends of the shock cord shall have ellipse spring loaded cord locks. The shock cord should not extend more than 3" when the garment is fully extended;
- (g) The two-piece articulated sleeves will have a separate adjustable cuff. Roughly half of the cuff will be shirred to 1 ½" elastic. The cuff will be adjusted with hook and loop fasteners;

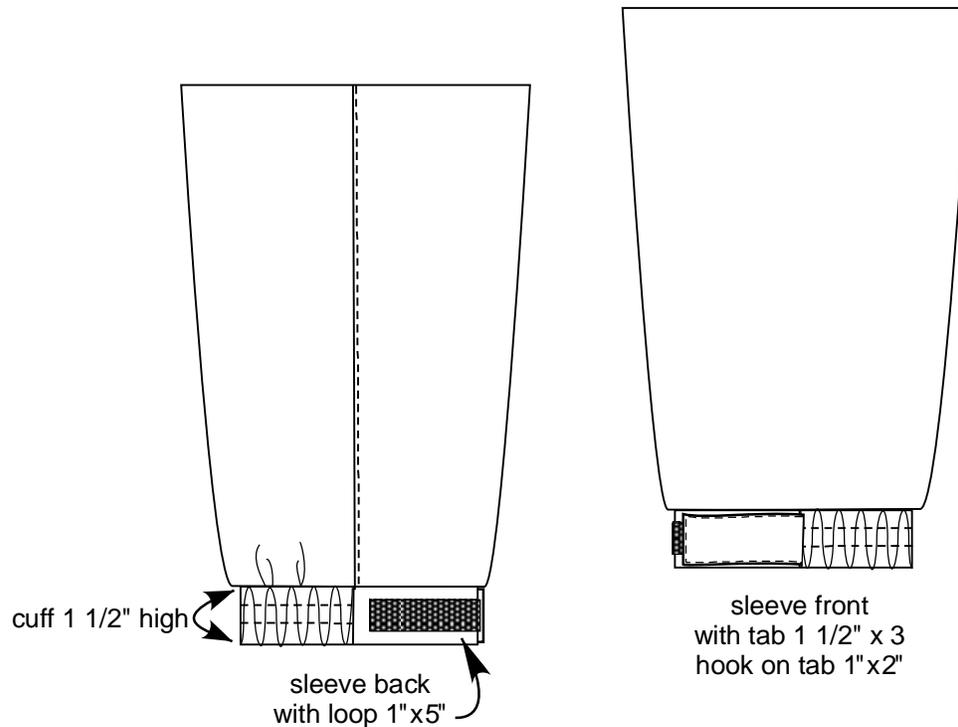

- (h) Sleeves will have Winnipeg Transit shoulder flashes centered on the sleeve cap 1 1/4" from seam;
- (i) A dome tab shall be set on the inside cuff. The tab will close towards the shell.;
- (j) There will be 14" PU coated pit zip sewn into each underarm seam. The pit zip will have two back to back sliders;
- (k) There shall be a 3 1/4" stand collar. It will be made of two pieces of shell and will be interlined with non-woven canvas. There will be 3 domes near the neckline to correspond to the domes of the hood. The top of the slide fasteners will be covered with a triangular piece of shell fabric;
- (l) All shell seams will be taped with compatible seam sealing tape;
- (m) The garment will be fully lined. There will be two chest pockets with a 1" x 1" hook and loop fastener closure. A hanger loop will be made of shell fabric and will be set at the centre back neck;
- (n) Lining will be sewn to shell, turned and topstitched with 1/8" stitch. The hem will be sewn to create a hem channel that will include a shock cord with cord locks;
- (o) A content label will be sewn inside on the left front pocket. Label will indicate washing instructions, fibre content and have space for individuals' name;
- (p) There will be a three piece fitted hood with a front hook and loop closure. A 1" piece of silver reflective will be set along the top of the centre hood. Along the neckline there will be dome fasteners that align with the domes on the collar. The hood will have an attached peak at the front, along with an adjustable shock cord drawstring set along the face. The shock cord will be finished with an ellipse cord lock;

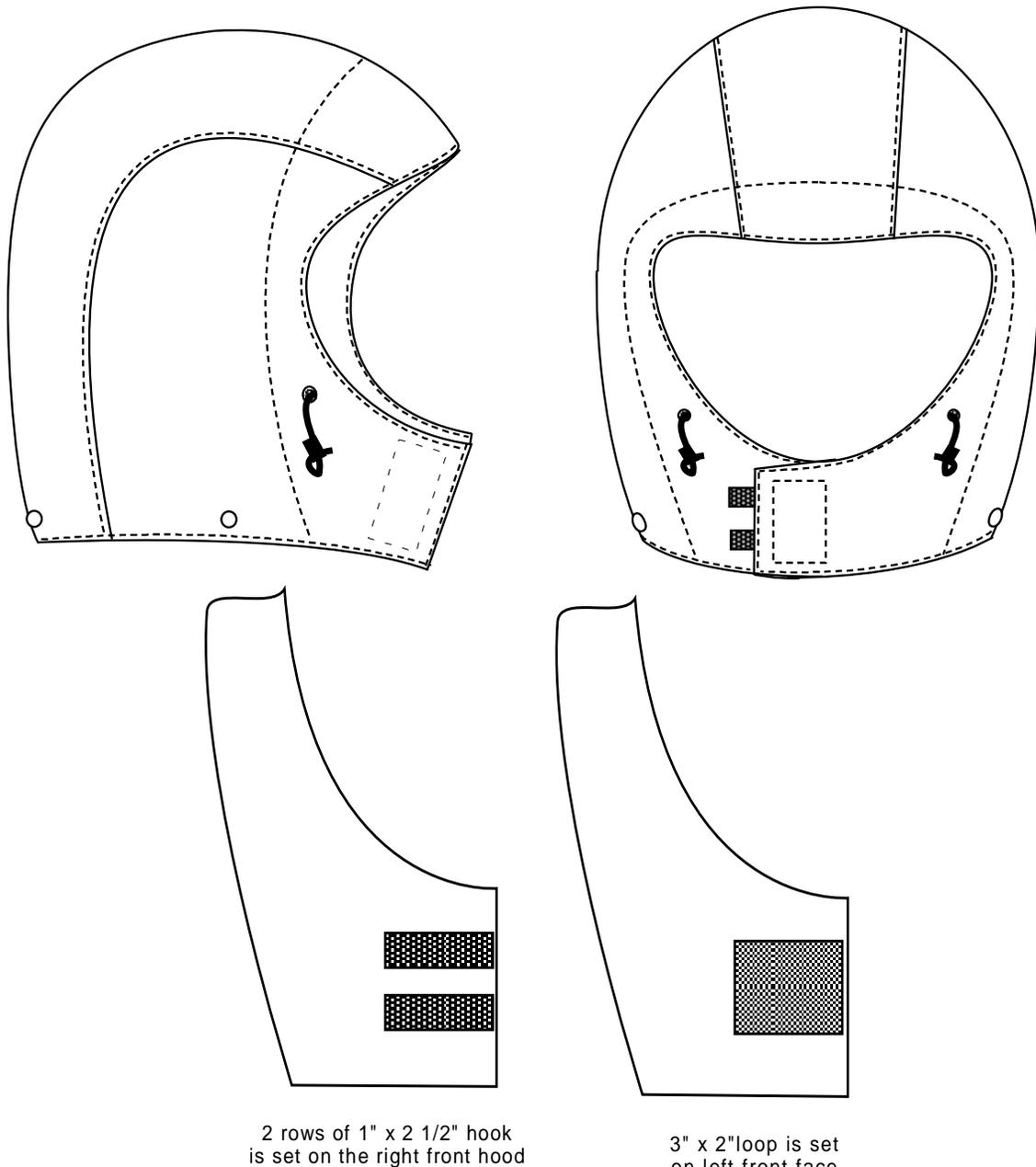

E9.2 Inner Shell:

- (a) There shall be a one piece back with one row of 2" reflective tape heat set across the back yoke about 6" from neckline;
- (b) Each front will have a piece of 1" reflective set across the front yoke about 6 1/2" from centre front neckline. A Winnipeg Transit reflective logo shall be set at the left front yoke 1/2" about the reflective tape and 2" from finished centre front;
- (c) Each front will have 7" front coil zipper pockets hidden behind a 3/4" shell fabric pocket welt. The zipper will close up;
- (d) There shall be two piece articulated sleeves with 2" shirred elastic cuffs. A gross grain loop shall be sewn into the underarm cuff seam to correspond to the dome tab of the shell. Each sleeve will have a Winnipeg Transit shoulder flash centered on the sleeve cap, about 1 1/4" from the seam;
- (e) There shall be a stand collar, with fleece lining and non-woven canvas interlining. The front Vislon zip closure shall be backed with a full front fly facing;

- (f) There shall be a self-fabric hanger loop sewn into the inside neckline and a dome tab sewn at the centre back neck of the shell. The dome tab must correspond to the hanger loop of the outer shell;
- (g) Each side seam will have 5" side seam zippers;
- (h) This jacket will be fully lined with nylon quilted to 100% polyester with a CLO value before quilting of 540;
- (i) Inside each front chest, there will be a 6" x 7" patch pocket with a 1" hook and loop closure;
- (j) A label with washing instructions, fibre content and a space for name shall be set on the pocket back at the left front chest.

E9.3 Soft Shell Fleece:

- (a) There is a two piece back of the bonded fleece/mesh material. There will be a 2" strip of reflective tape set across the back nylon yoke ¼" above the seam line. The lower body will be sandwiched between the back outer yoke and fleece yoke to create a clean finished seam on the inside and out;
- (b) Each front will be in two pieces. Each lower front will have an exposed 7" Vislon zipper pocket. The left front shall have an additional 6" pocket set 1" parallel to the front zipper 1" away from the front yoke;
- (c) There shall be a front yoke in the bonded fleece fabric and an outer yoke in the nylon fabric. The front yoke shall have 1" reflective tape set across the front along the seam line. There shall also be a reflective Winnipeg transit logo heat set on the left front yoke 2' from the centre front edge and ½' from the reflective tape;
- (d) The 3 ¾" collar shall be made with the bonded fleece facing the inside neck, a 1" strip of bonded fleece along the top edge and a 2 ¾" piece of nylon set along the neckline. The collar shall have a hanger loop set at the inside centre back neck. The neckline seam allowance of the neckline seam will be enclosed in the collar;
- (e) The two-piece articulated sleeves will have a large nylon elbow patch. There will be a shaped Lycra cuff set inside the 1" hem to extend 2" beyond the fleece cuff. There will be the additional option of the thumb hole;
- (f) Each flash shall have a Winnipeg Transit shoulder flash centered about 11/2" from the bound sleeve cap;
- (g) There will be a nylon facing for the armhole. One edge of a separating coil zipper will be set along the facing and one edge along the top of the sleeve. The facing will be set to the armhole and topstitched ¼" and 3/4" along the armhole;
- (h) There will be a 5" open end coil zipper set at each side seam;
- (i) Each hem panel will be faced with nylon and topstitched to create a hem channel about 1" high. Each channel will have a shock cord that does not extend more than 3" from the eyelet opening when the garment is fully extended. The shock cords will each have an ellipse cord lock;
- (j) The front closure will be #5 Vislon two way zipper backed with a bound fleece front fly;
- (k) A label with washing instructions, fibre content and a space for name shall be set on the pocket back at the left front chest.
- (l) The two piece articulated sleeves will have a large nylon elbow patch. There will be a shaped Lycra cuff set inside the 1" hem to extend 2" beyond the fleece cuff. There will be the additional option of the thumb hole;
- (m) Each flash shall have a Winnipeg Transit shoulder flash centered about 11/2" from the bound sleeve cap;
- (n) There will be a nylon facing for the armhole. One edge of a separating coil zipper will be set along the facing and one edge along the top of the sleeve. The facing will be set to the armhole and topstitched ¼" and 3/4" along the armhole;
- (o) There will be a 5" open end coil zipper set at each side seam;

- (p) Each hem panel will be faced with nylon and topstitched to create a hem channel about 1" high. Each channel will have a shock cord that does not extend more than 3" from the eyelet opening when the garment is fully extended. The shock cords will each have an ellipse cord lock;
- (q) The front closure will be #5 Vislon two way zipper backed with a bound fleece front fly;
- (r) A label with washing instructions, fibre content and a space for name shall be set on the pocket back at the left front chest.

E10. MEASUREMENTS AND SIZING

E10.3 All garments shall be in accordance with the following measurements:

- (a) Sizes:
 - (i) Garments identified as Extra Small (XS) shall fit chest sizes 31 to 34
 - (ii) Garments identified as Small (S) shall fit chest sizes 33 to 36
 - (iii) Garments identified as Medium (M) shall fit chest sizes 37 to 40
 - (iv) Garments identified as Large (L) shall fit chest sizes 41 to 44
 - (v) Garments identified as Extra Large (XL) shall fit chest sizes 45 to 48
 - (vi) Garments identified as 2 Extra Large (XXL) shall fit chest sizes 49 to 52
 - (vii) Garments identified as 3 Extra Large (XXXL) shall fit chest sizes 53 to 56
- (b) Height Measurements:
 - (i) Garments identified as Short shall fit individuals who are 5'3" to 5'6" in height
 - (ii) Garments identified as Regular shall fit individuals who are 5'7" to 5'10" in height
 - (iii) Garments identified as Tall shall fit individuals who are 5'11" to 6'2" in height

E10.4 The following measurements charts are applicable (all measurements are shown in inches), and all sizes indicated in the chart shall be available:

Measurement Chart for Outer Shell							
Short (5'3" to 5'6")	XS	S	M	L	XL	XXL	
back length from neckline	32 1/2	32 1/2	32 1/2	32 1/2	32 1/2	32 1/2	
chest	46	48	52	56	60	64	
waist	44	46	50	54	58	62	
hem	45	47	51	55	59	63	
sleeve length from centre-back	34	35	35 1/2	36	36 1/2	37	
Regular (5'7" to 5'10")	XS	S	M	L	XL	XXL	XXXL
back length from neckline	34 1/2	34 1/2	34 1/2	34 1/2	34 1/2	34 1/2	34 1/2
chest	46	48	52	56	60	64	68
waist	44	46	50	54	58	62	66
hem	45	47	51	55	59	63	67
sleeve length from centre-back	35	36	36 1/2	37	37 1/2	38	38 1/2

Tall (5'11" to 6'2")			M	L	XL	XXL	XXXL
back length from neckline			36 1/2	36 1/2	36 1/2	36 1/2	36 1/2
chest			52	56	60	64	68
waist			50	54	58	62	66
hem			51	55	59	63	67
sleeve length from centre-back			37 1/2	38	38 1/2	39	39 1/2

Measurement Chart for Inner Shell							
Short (5'3" to 5'6")	XS	S	M	L	XL	XXL	
back length from neckline	28	28	28	28	28	28	
chest	45	47	51	55	59	63	
hem	43	45	49	53	57	61	
sleeve length from centre-back	33 1/2	34 1/2	35	35 1/2	36	36 1/2	
Regular for 5'7" to 5'10"	XS	S	M	L	XL	XXL	XXXL
back length from neckline	30	30	30	30	30	30	30
chest	45	47	51	55	59	63	67
hem	43	45	49	53	57	61	65
sleeve length from centre-back	34 1/2	35 1/2	36	36 1/2	37	37 1/2	38
Tall (5'11" to 6'2")			M	L	XL	XXL	XXXL
back length from neckline			32	32	32	32	32
chest			51	55	59	63	67
hem			49	53	57	61	65
sleeve length from centre-back			37	37 1/2	38	38 1/2	39

Measurement Chart for Soft Shell Fleece							
Short (5'3" to 5'6")	XS	S	M	L	XL	XXL	
back length from neckline	28	28	28	28	28	28	
chest	42	44	48	52	56	60	

hem	38	40	44	48	52	56	
sleeve length from centre-back	34	35	35 1/2	36	36 1/2	37	
Regular (5'7" to 5'10")	XS	S	M	L	XL	XXL	XXXL
back length from neckline	30	30	30	30	30	30	30
chest	42	44	48	52	56	60	64
hem	38	40	44	48	52	56	60
sleeve length from centre-back to fleece cuff		36	36 1/2	37	37 1/2	38	38 1/2
Tall (5'11" to 6'2")			M	L	XL	XXL	XXXL
back length from neckline			32	32	32	32	32
chest			48	52	56	60	64
hem			44	48	52	56	60
sleeve length from centre-back			37 1/2	38	38 1/2	39	39 1/2

Table 1 Shell Fabric

Property	Test Method	Specified Requirements
Mass	Test Method #5.1 CAN/CSGB-4.2	130 +/- 5g/m ²
Water Repellency	Test Method #26.2 CAN/CSGB-4.2	Rating=100 As received
Water column	Test Method #26.3 CAN/CSGB-4.2	5000mm As received
Breathability	ASTM E-96-00 Procedure E	2500g/m ² x 24 hrs
Breaking Strength	Test Method #9.1 CAN/CSGB-4.2	Warp: 525N Weft:600N
Tear Strength	Test Method #12.1 CAN/CSGB-4.2	Warp: 22N Weft:28N

Table 2 Lining Fabric

Property	Test Method	Specified Requirements	Minimum	Maximum
Fabric Count (yarns/cm)	Test Method #6 CAN/CSGB-4.2	Warp: 64 Weft: 34	Warp: 60 Weft: 32	
Mass	Test Method #5.1 CAN/CSGB-4.2	88g/m ²	78g/m ²	90g/m ²
Breaking Strength	Test Method #9.1 CAN/CSGB-4.2	Warp:845N Weft:535N	Warp: 735N Weft:465N	
Dimensional change in Laundry after 5 washes	Wash in as per: 6330 (2A)or (2B) Procedure E Measure as per:675 paras 6 &7.4 ISO Textile Test Methods			Warp 3% Weft 3%
Non Fibrous Material	Test Method #15 Paragraph 7.4 Solvent extraction One of petroleum ether, tetracholoroethylene or hexane shall be used. CAN/CSGB-4.2			2%
Colour fastness to Light	Test Method #16 Option E AATCC Textile Methods	Sample Grey Scale 4 after 40AATCC fading units	Sample Grey Scale 4 after 20 AATCC fading units	
Colour fastness to water	Test Method #20 CAN/CSGB-4.2	Sample Grey Scale 4. No colour change and staining.	Sample Grey Scale 3.	Sample Grey Scale 4.
Colour fastness to crocking	Test Method #22 CAN/CSGB-4.2	No change and staining. Wet:grey scale 4 Dry: grey scale 4	Wet: grey scale 3 Dry: grey scale 3	Wet: grey scale 4 Dry: grey scale 4
Colour fastness to Perspiration	Test Method #23 CAN/CSGB-4.2	No change and staining. Grey scale 4	No appreciable change in colour. grey scale 3	No appreciable change in colour. grey scale 4
Colour fastness to Dry Cleaning	Test Method #29.1 CAN/CSGB-4.2	No change in colour Grey scale 4	No appreciable change in colour. grey scale 3	No appreciable change in colour. grey scale 4