

**WATER SERVICE INFORMATION**

ADDRESS	MATERIAL (STREET)	SIZE (mm) (PROP.)	SIZE (mm) (PROP.)	SHORT & LONG MEASUREMENT	CORP. LOCATION	REMARKS
471 EDISON AVE	-	-	20	1.67 WEL HSE	10.5 E OF S/C	OUTSIDE LIMITS
RESIDENTIAL	-	-	CU	25.765 WML MACAULAY PL	-	-
475 EDISON AVE	-	-	20	2.85 NSL HSE	-	OUTSIDE LIMITS
RESIDENTIAL	-	-	CU	4.726 NNL EDISON AVE	-	-
478 EDISON AVE	-	-	20	5.16 EWL HSE	-	OUTSIDE LIMITS
RESIDENTIAL	-	-	CU	6.080 WML MACAULAY PL	-	-
482 EDISON AVE	-	-	20	4.64 EWL HSE	-	OUTSIDE LIMITS
RESIDENTIAL	-	-	CU	10.014 EWL MACAULAY PL	-	OUTSIDE LIMITS
486 EDISON AVE	-	-	20	8.11 EWL HSE	-	OUTSIDE LIMITS
RESIDENTIAL	-	-	CU	25.746 EWL MACAULAY PL	-	-
490 EDISON AVE	-	-	20	5.96 EWL HSE	-	OUTSIDE LIMITS
RESIDENTIAL	-	-	CU	40.041 EWL MACAULAY PL	-	-
491 EDISON AVE	-	-	20	6.50 NSL HSE	-	RECONNECT SERVICE
RESIDENTIAL	-	-	CU	9.166 NNL EDISON AVE	-	-
494 EDISON AVE	-	-	20	11.14 EWL HSE	-	RECONNECT SERVICE
RESIDENTIAL	-	-	CU	60.679 EWL MACAULAY PL	-	-
498 EDISON AVE	-	-	20	7.96 EWL HSE	-	RECONNECT SERVICE
RESIDENTIAL	-	-	CU	4.130 EWL MACAULAY CR	-	-
502 EDISON AVE	-	-	20	8.57 EWL HSE	-	RECONNECT SERVICE
RESIDENTIAL	-	-	CU	17.986 EWL MACAULAY CR	-	-
506 EDISON AVE	-	-	20	9.43 EWL HSE	-	RECONNECT SERVICE
RESIDENTIAL	-	-	CU	33.725 EWL MACAULAY CR	-	-
510 EDISON AVE	-	-	20	5.59 EWL HSE	-	RENEW TO R W/20 CU
RESIDENTIAL	-	-	CU	18.352 WML BROAD BAY (W-LEG)	-	DUE TO TREE
514 EDISON AVE	-	-	20	2.37 EWL HSE	-	RECONNECT SERVICE
RESIDENTIAL	-	-	CU	6.728 WML BROAD BAY (W-LEG)	-	-
518 EDISON AVE	-	-	20	4.88 EWL HSE	-	RECONNECT SERVICE
RESIDENTIAL	-	-	CU	9.004 EWL BROAD BAY (W-LEG)	-	-
522 EDISON AVE	-	-	20	1.52 EWL HSE	-	RECONNECT SERVICE
RESIDENTIAL	-	-	CU	24.210 EWL BROAD BAY (W-LEG)	-	-
525 EDISON AVE	-	-	20	1.83 NSL HSE	-	OUTSIDE LIMITS
RESIDENTIAL	-	-	CU	11.169 NNL EDISON AVE	-	-
526 EDISON AVE	-	-	20	2.59 EWL HSE	-	RENEW TO R W/20 CU
RESIDENTIAL	-	-	CU	39.627 EWL BROAD BAY (W-LEG)	-	DUE TO TREE
530 EDISON AVE	-	-	20	3.39 EWL HSE	-	RECONNECT SERVICE
RESIDENTIAL	-	-	CU	53.008 EWL BROAD BAY (W-LEG)	-	-
534 EDISON AVE	-	-	20	3.87 EWL HSE	-	RENEW TO R W/20 CU
RESIDENTIAL	-	-	CU	68.416 EWL BROAD BAY (W-LEG)	-	DUE TO TREE
538 EDISON AVE	-	-	20	3.24 EWL HSE	-	OUTSIDE LIMITS
RESIDENTIAL	-	-	CU	100.171 EWL BROAD BAY (W-LEG)	-	-

\* SERVICES TO BE RENEWED TO R. ALL OTHERS TO BE RECONNECTED

NOTE: CHAINAGES SHOWN ARE ALONG S. R. OF EDISON AVENUE

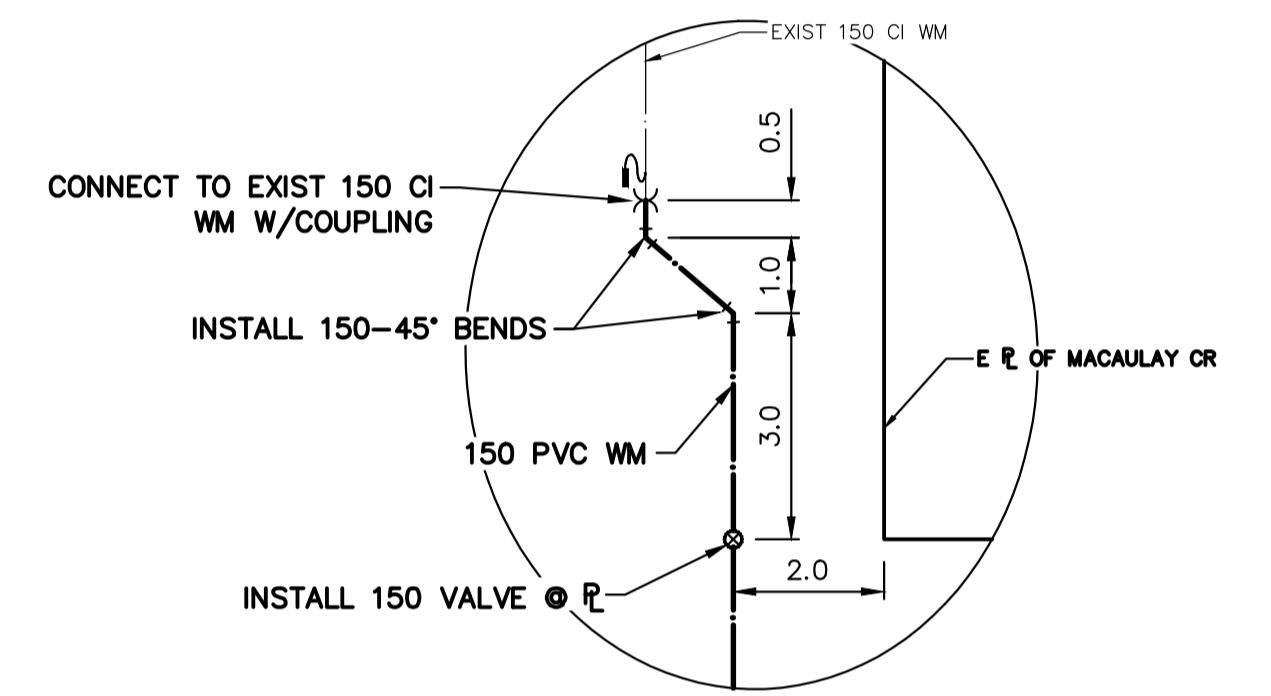
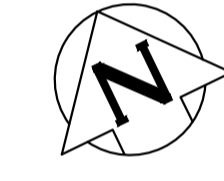

DETAIL "B" SCALE N.T.S.

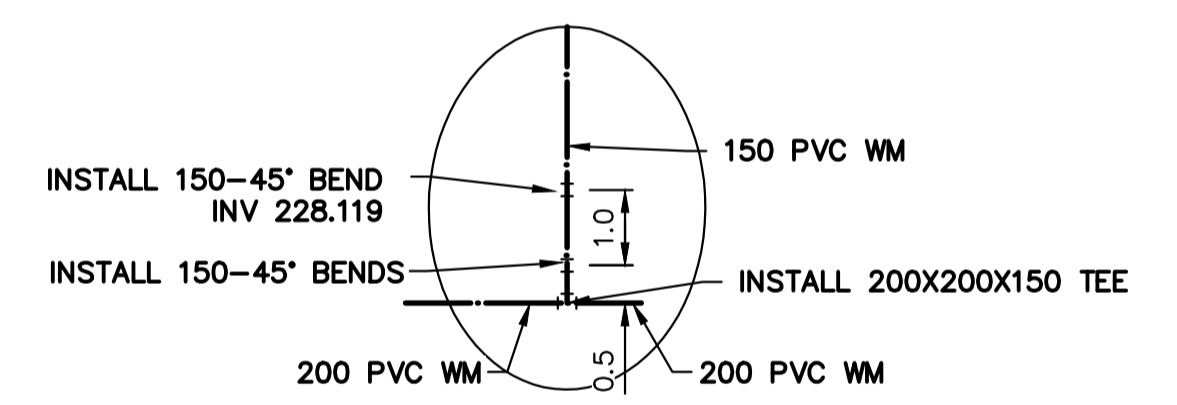

DETAIL "A" SCALE N.T.S.

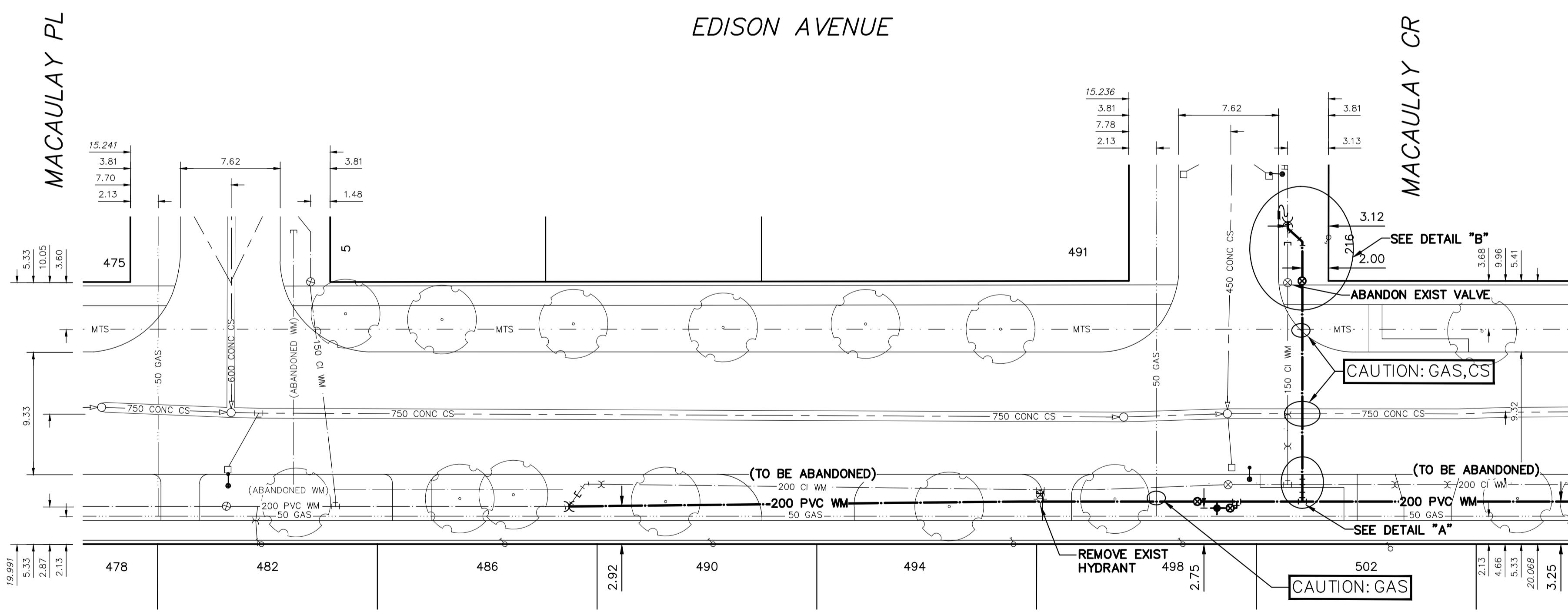

MATCHLINE 2+10.000  
SEE DWG D-15398

FOR INDEX SEE D-15396

NOTE: ALL VALVES TO BE INSTALLED COUNTERCLOCKWISE TO CLOSE

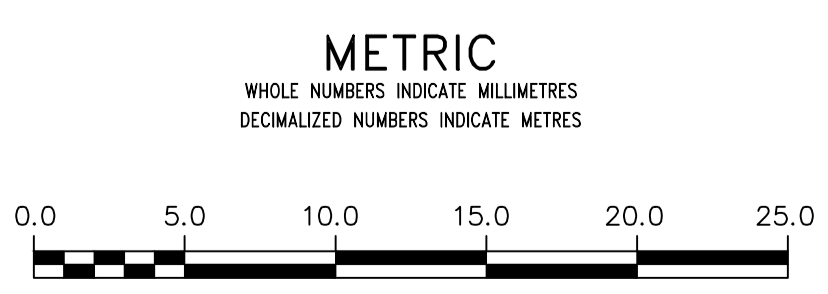

**WARNING**  
IF POWER EQUIPMENT OR EXPLOSIVES ARE TO BE USED FOR EXCAVATION ON THIS PROJECT THE CONTRACTOR MUST:  
1) NOTIFY THE GAS COMPANY OF THE PROPOSED LOCATION OF EXCAVATION.  
2) TAKE PRECAUTION TO AVOID DAMAGE TO GAS COMPANY INSTALLATIONS.  
SEE PROVINCIAL REGULATION 210/72 FOR DETAILS

**LOCATION APPROVED UNDERGROUND STRUCTURES**  
SUPP. U/G STRUCTURES COMMITTEE DATE  
NOTE:  
LOCATION OF UNDERGROUND STRUCTURES AS SHOWN ARE BASED ON THE BEST INFORMATION AVAILABLE BUT NO GUARANTEE IS GIVEN THAT ALL EXISTING UTILITIES ARE SHOWN OR THAT THE GIVEN LOCATIONS ARE EXACT. CONFIRMATION OF EXISTENCE AND EXACT LOCATION OF ALL SERVICES MUST BE OBTAINED FROM THE INDIVIDUAL UTILITIES BEFORE PROCEEDING WITH CONSTRUCTION.

B.M. ELEV.	NO.	REVISIONS	DATE	BY

DESIGNED BY	MJK	CHECKED BY	SC
DRAWN BY	AJ	APPROVED BY	KZ
SCALE:	HORIZONTAL 1:250 VERTICAL 1:50		
DATE	2019 03 26	RELEASED FOR CONSTRUCTION	K. ZUREK
PLOT DATE:	2019 03 26	DATE	2019-03-25

ENGINEER'S SEAL  
ORIGINAL SIGNED BY  
S.R.J.  
COURNOYER  
19/03/25  
CONSULTANT DRAWING NUMBER

**THE CITY OF WINNIPEG**  
WATER AND WASTE DEPARTMENT  
ENGINEERING DIVISION

2019 WATER MAIN RENEWALS  
CONTRACT 9  
EDISON AVENUE  
MACAULAY PLACE TO  
20 E OF MACAULAY CRESCENT

SHEET 3 OF 12  
CITY DRAWING NUMBER  
D-15397