

A DETAIL
S3.1 SCALE: 1:20

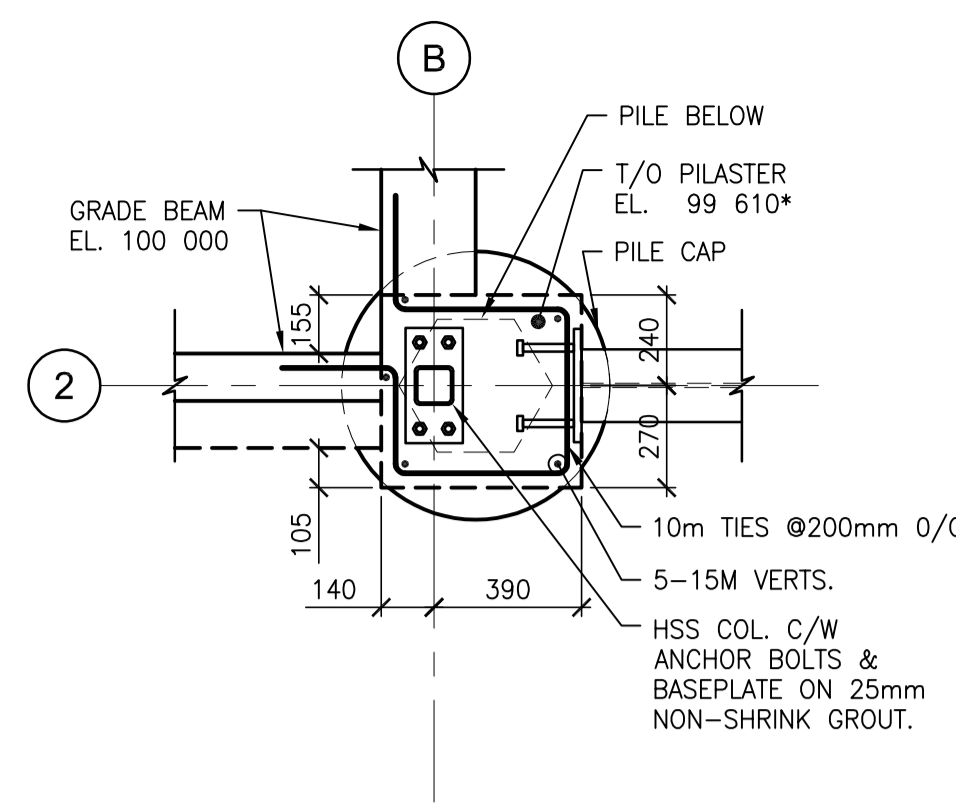

B DETAIL
S3.1 SCALE: 1:20

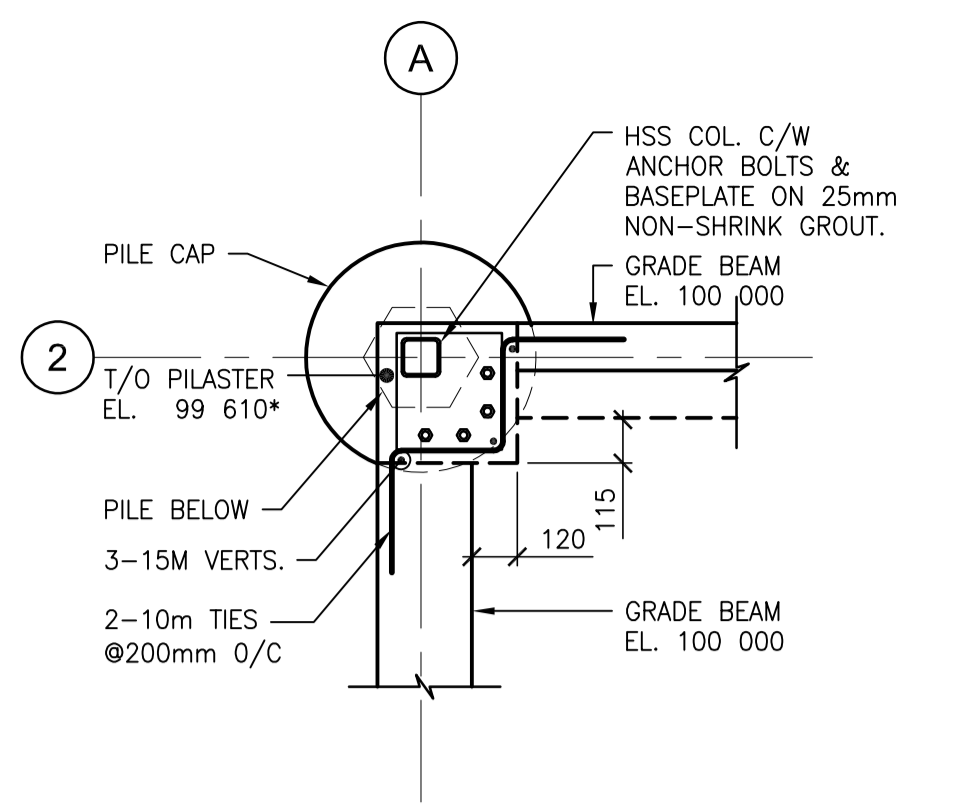

C DETAIL
S3.1 SCALE: 1:20

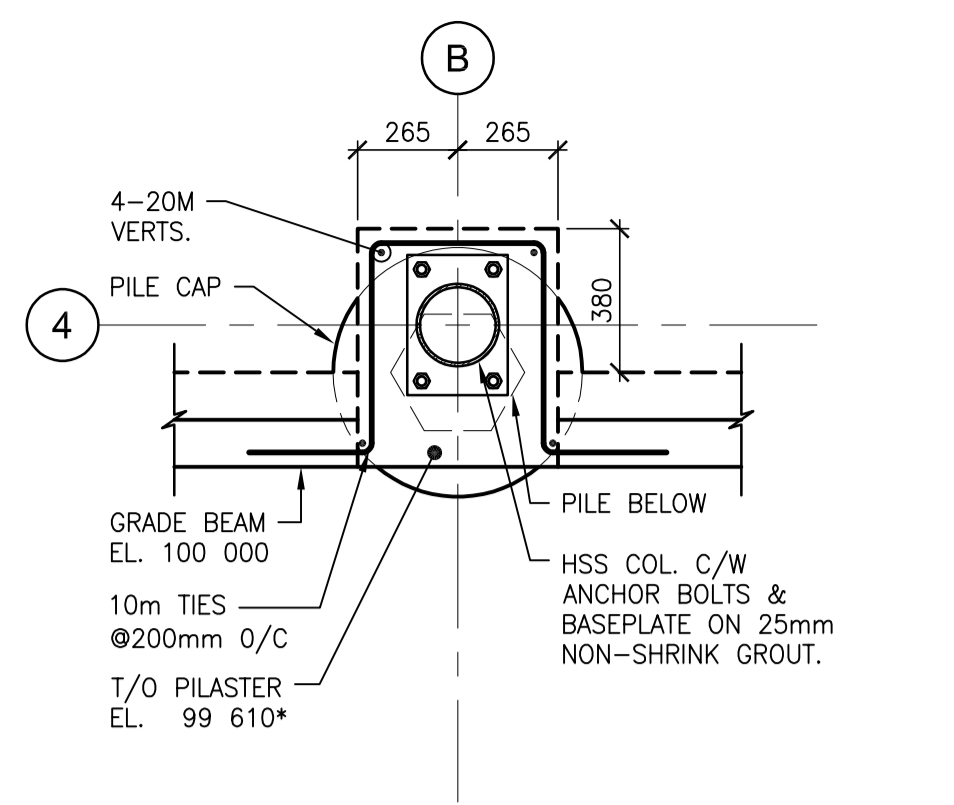

D DETAIL
S3.1 SCALE: 1:20

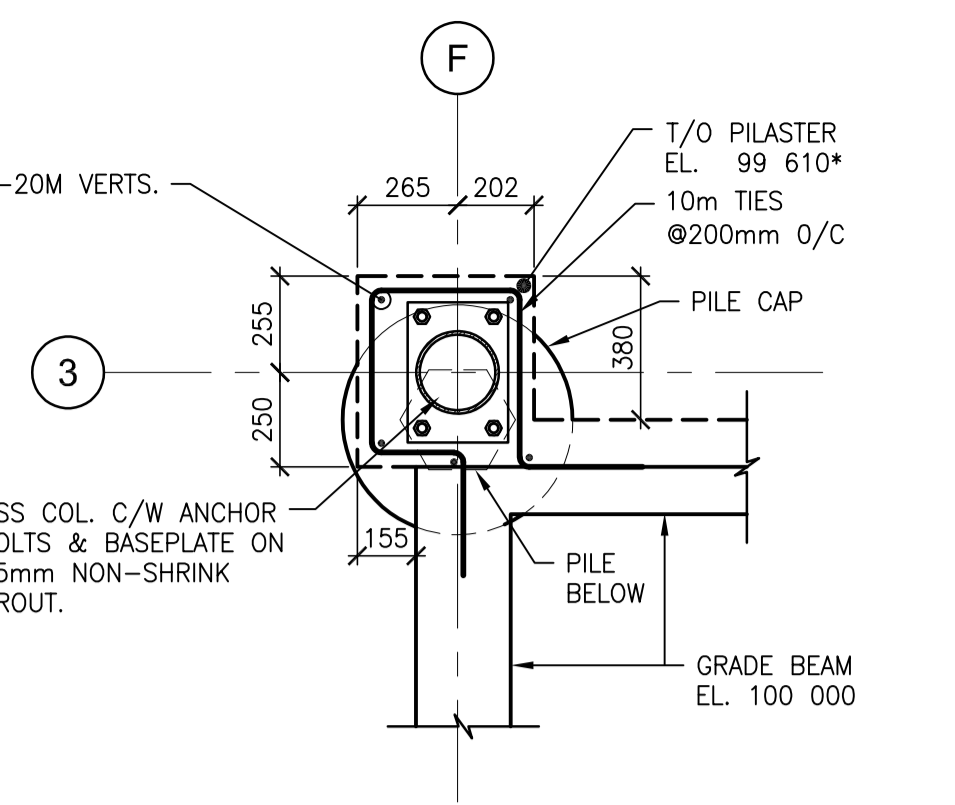

E DETAIL
S3.1 SCALE: 1:20

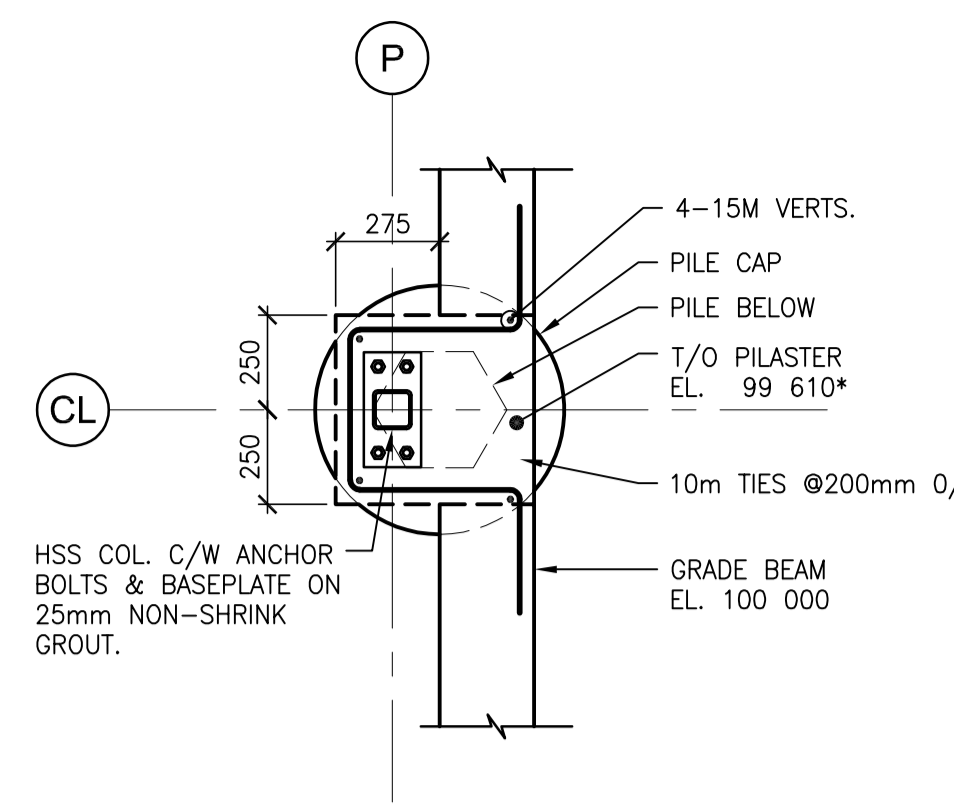

F DETAIL
S3.1 SCALE: 1:20

NOTE:
-CONTRACTOR TO CONFIRM UP-STAND HEIGHTS WITH HOLLOWCORE CAMBER AND TOPPING.
-T/O PILASTER EL. 99 610* TO BE CONFIRMED BY CONTRACTOR.

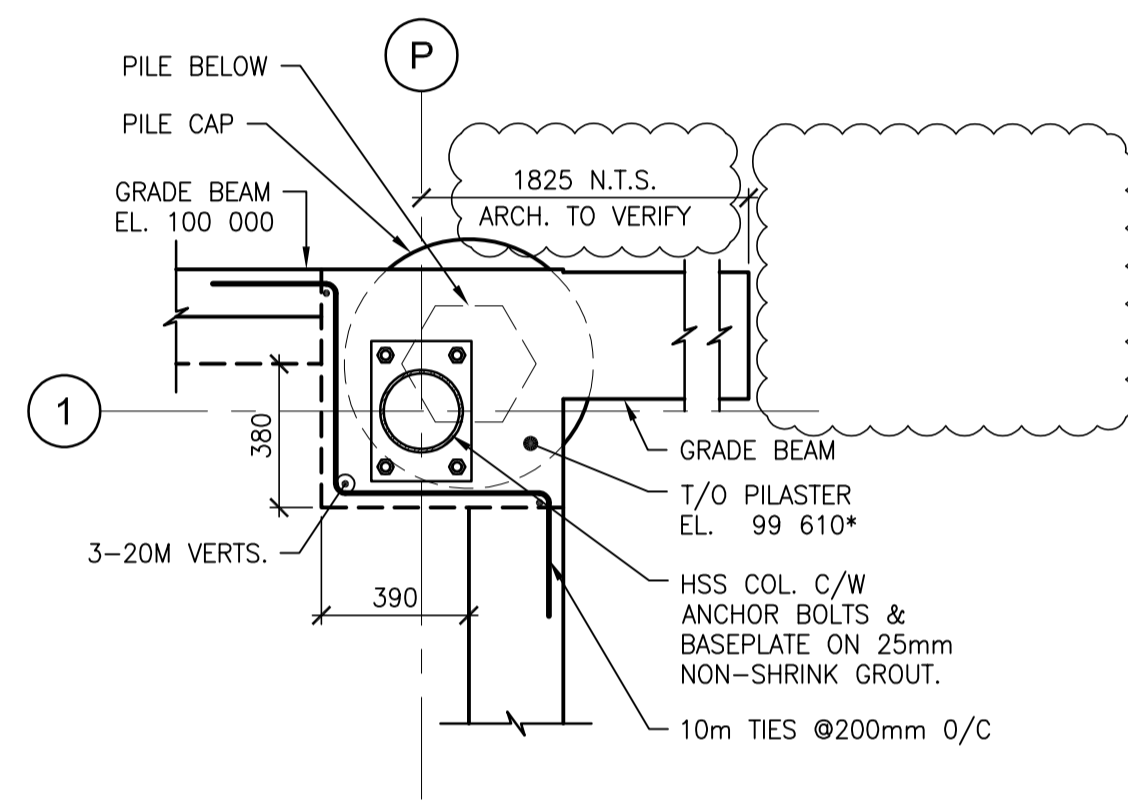

GR1 DETAIL
S3.1R1 SCALE: 1:20

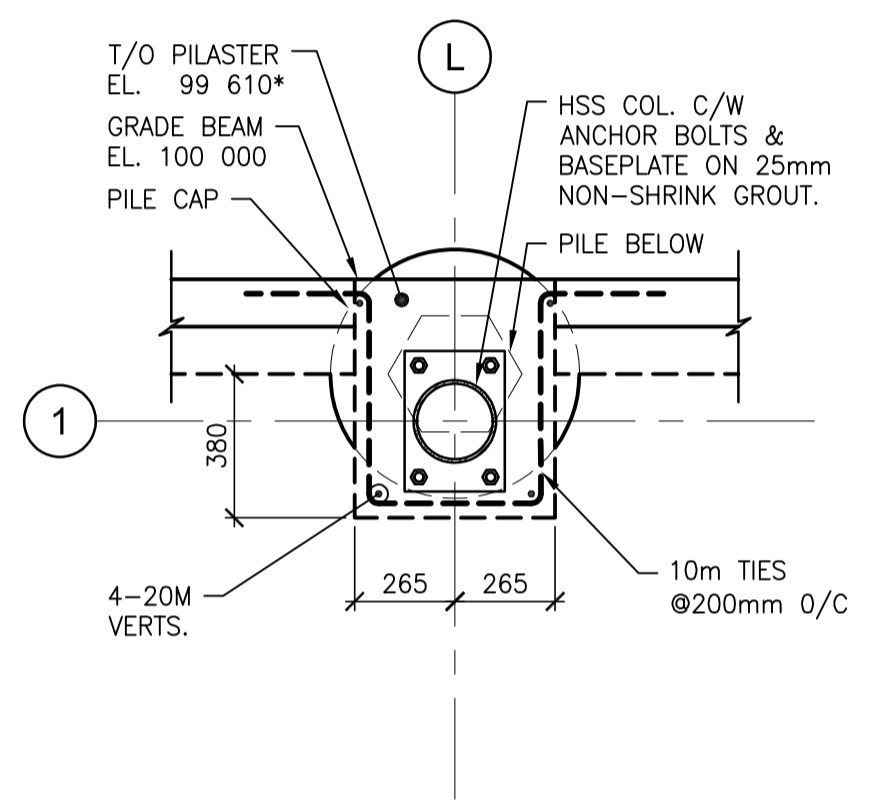

H DETAIL
S3.1 SCALE: 1:20

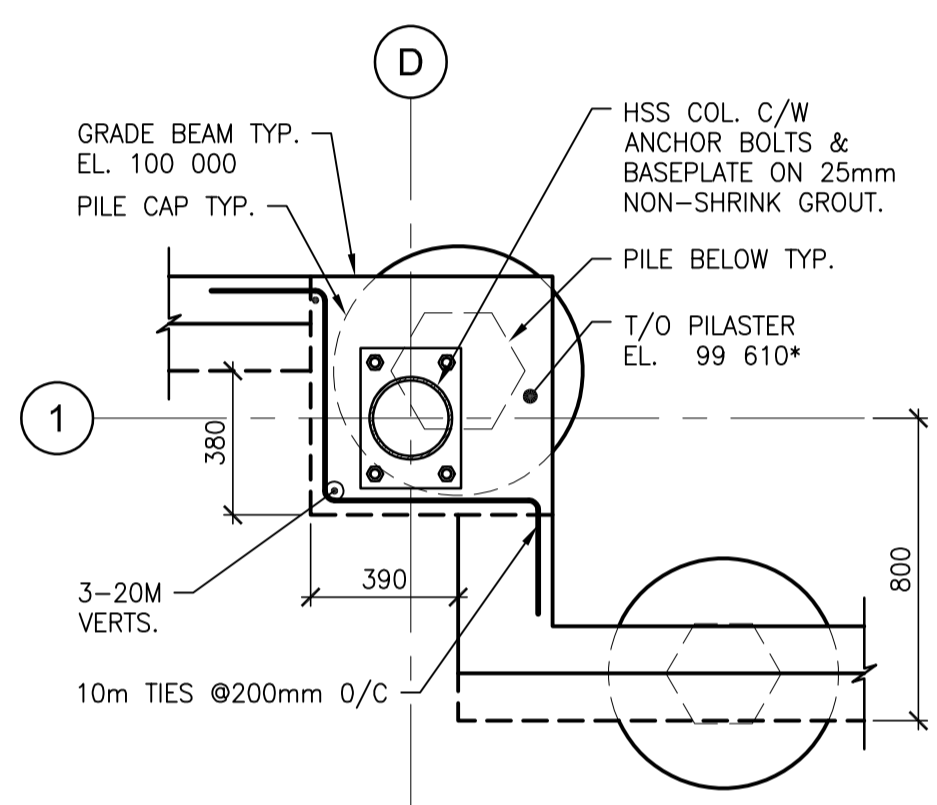

J DETAIL
S3.1 SCALE: 1:20

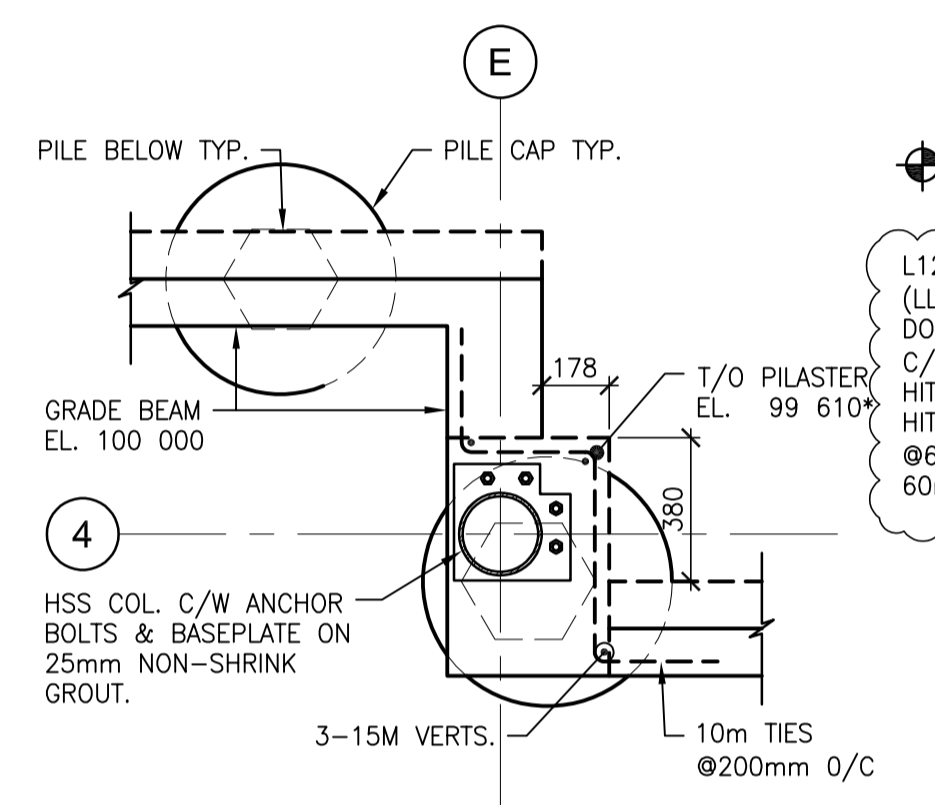

K DETAIL
S3.1 SCALE: 1:20

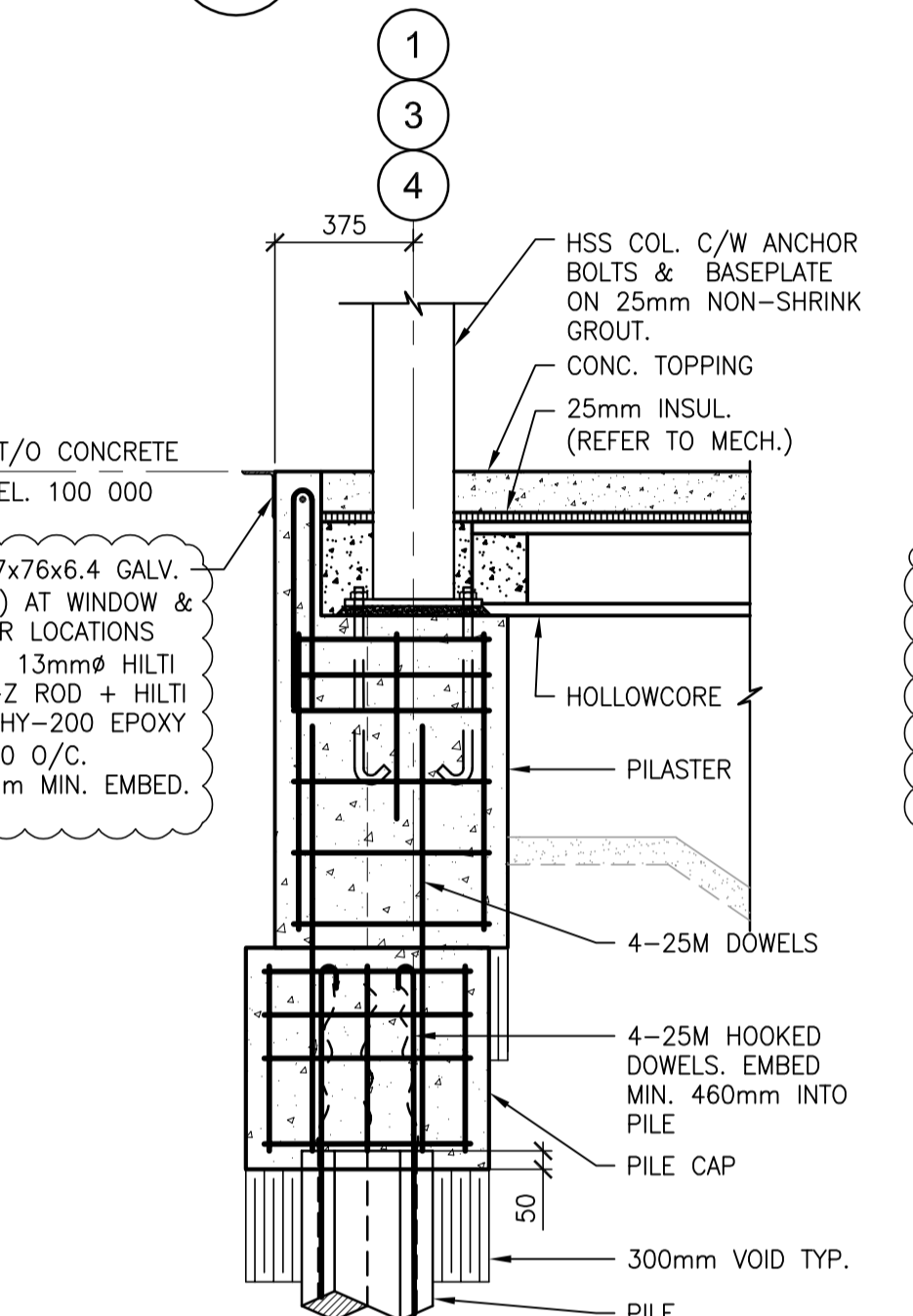

1R1 SECTION
S3.1R1 SCALE: 1:20

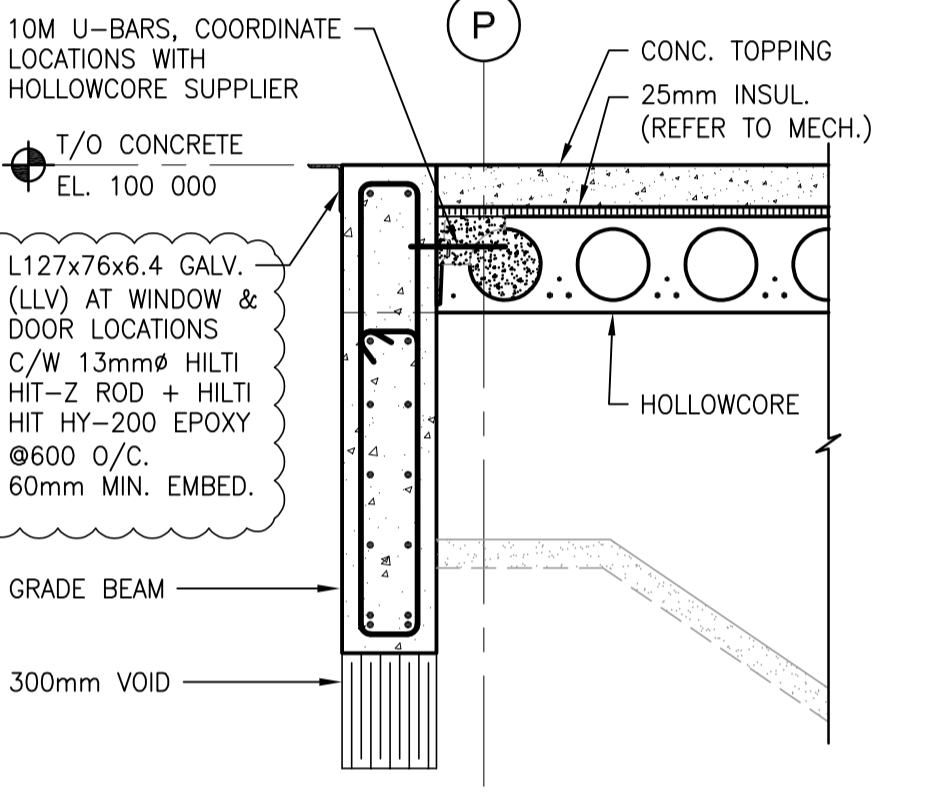

2R1 SECTION
S3.1R1 SCALE: 1:20

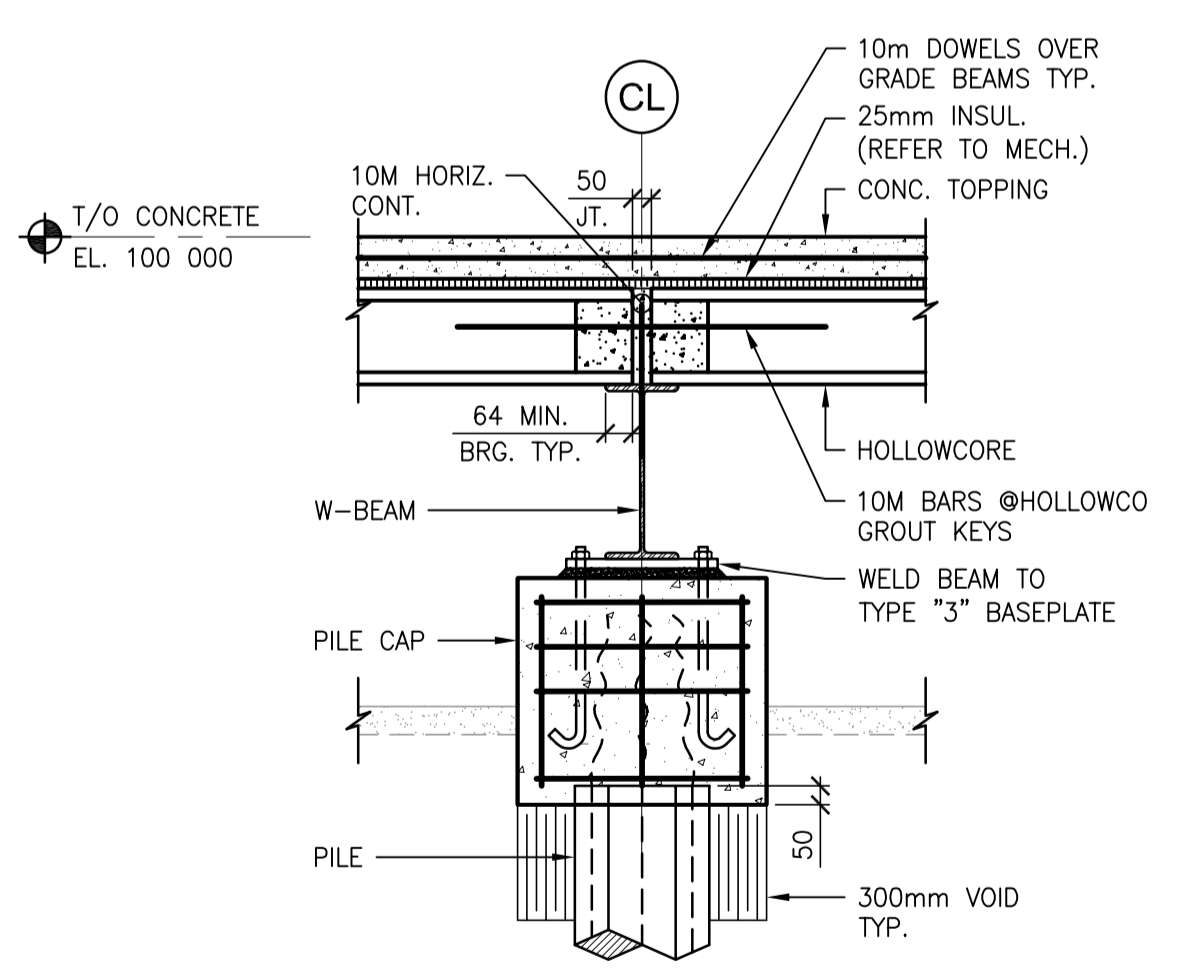

3 SECTION
S3.1 SCALE: 1:20

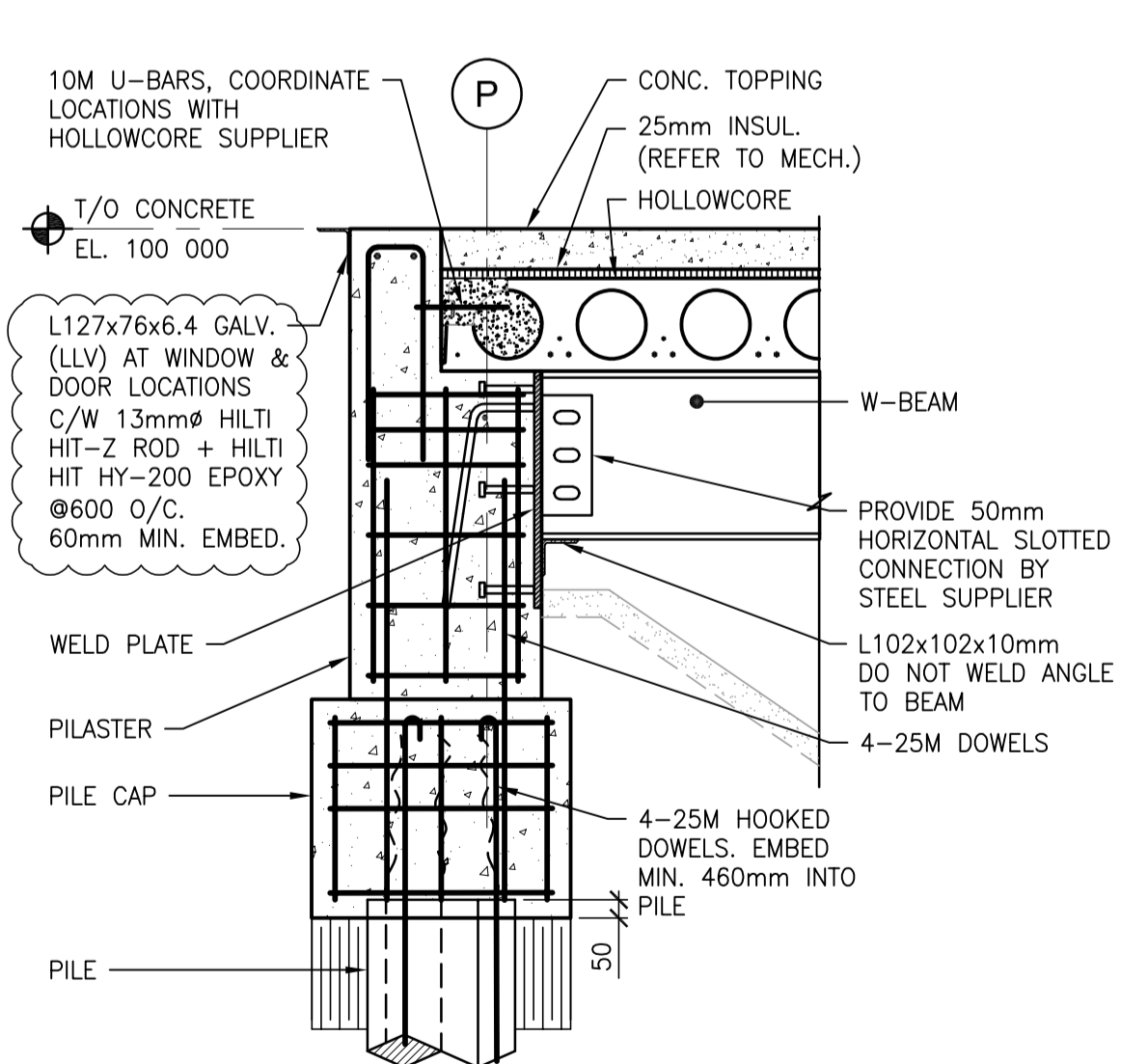

4R1 SECTION
S3.1R1 SCALE: 1:20

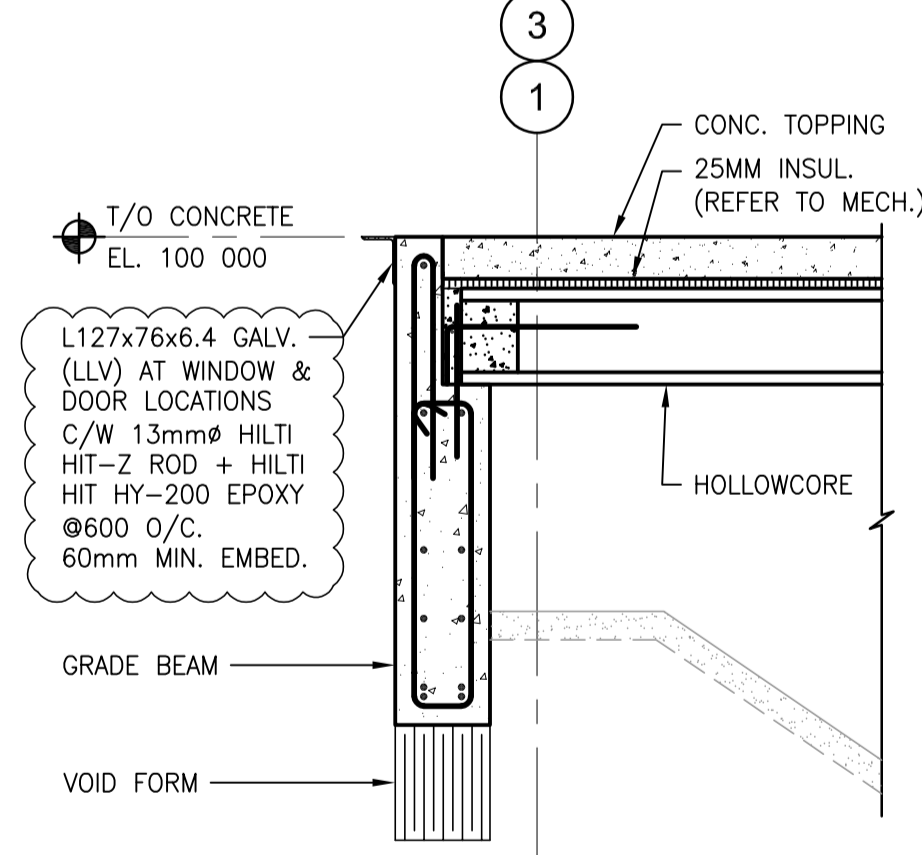

5R1 SECTION
S3.1R1 SCALE: 1:20

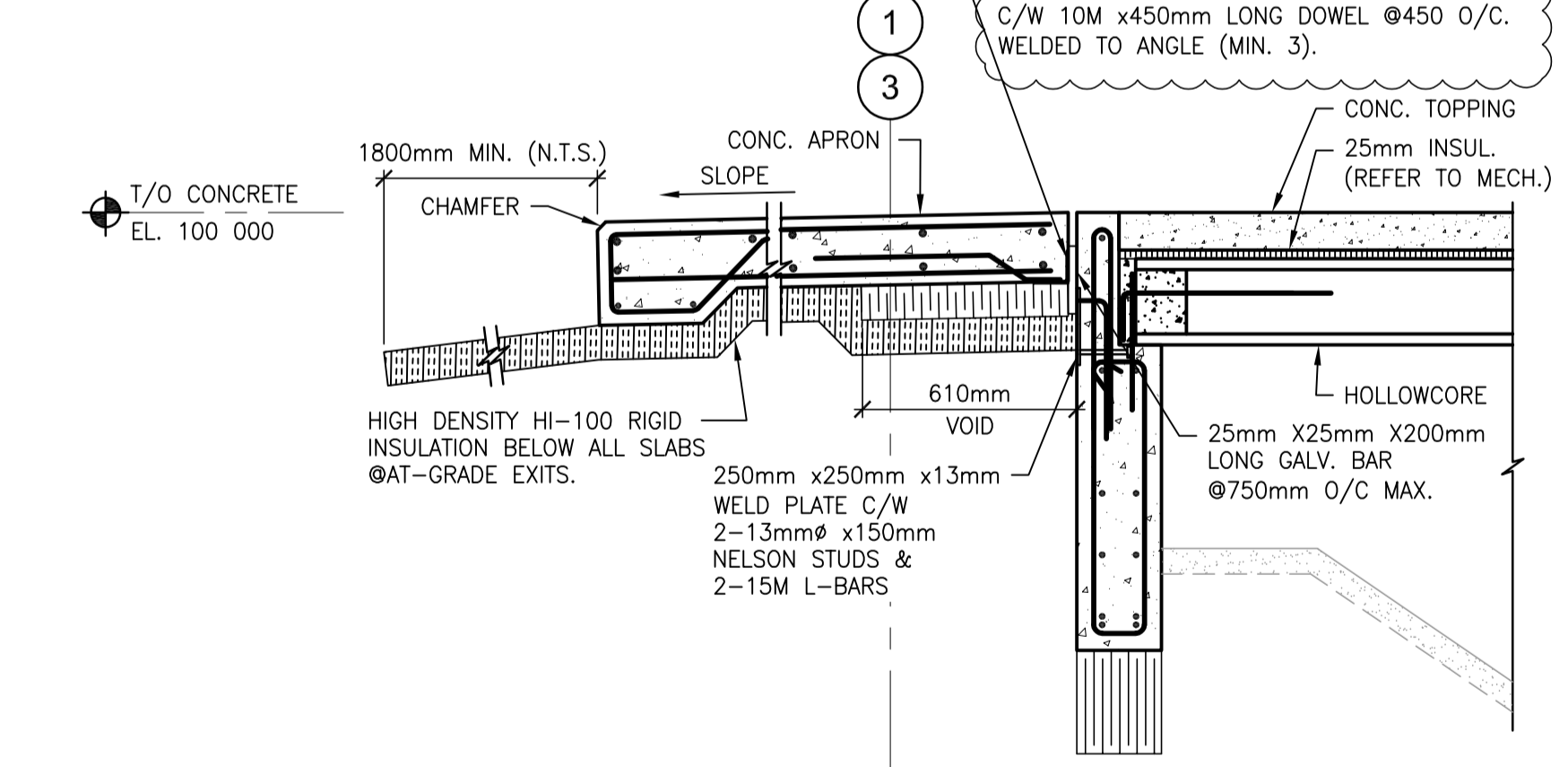

6R1 SECTION
S3.1R1 SCALE: 1:20

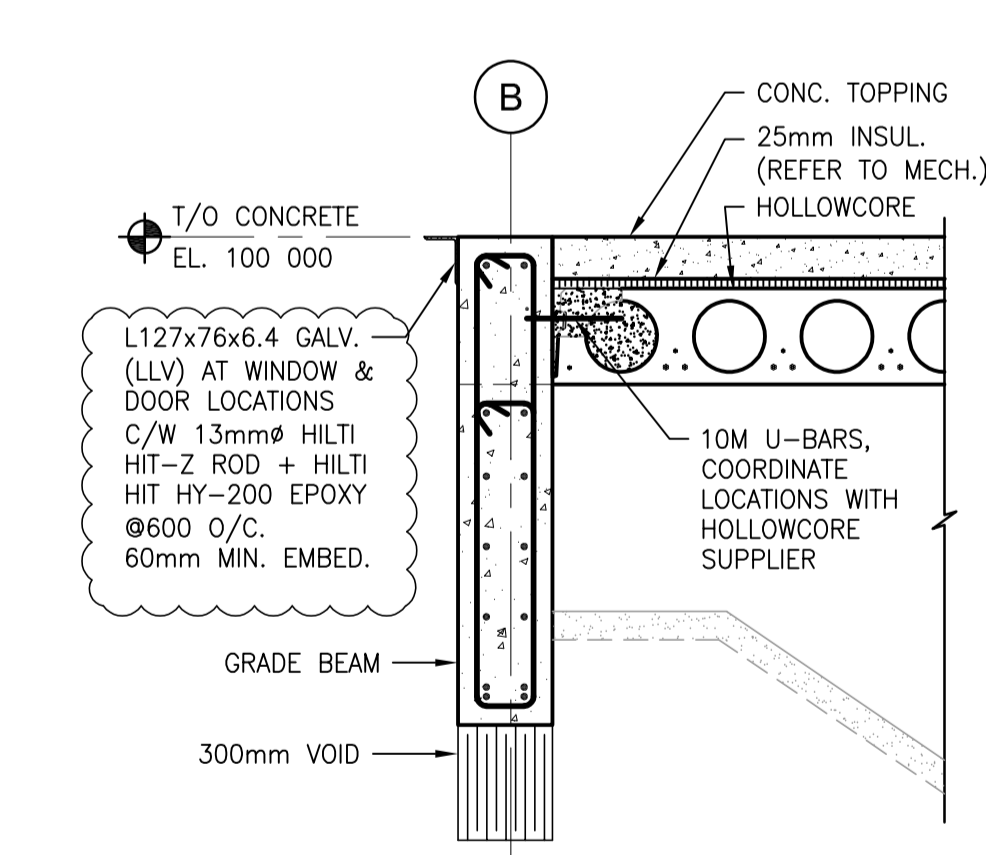

8R1 SECTION
S3.1R1 SCALE: 1:20

TOWER PROJECT NO. : 181335
TOWER ENGINEERING GROUP
 UNIT 1-1140 WAVERLEY ST. WINNIPEG, MB R3T 0P4
 TEL: (204) 925-1150 FAX: (204) 925-1155
 EMAIL: towereng@towereng.ca WEB: www.towereng.ca
 • WINNIPEG • CALGARY

No.	Date	Issue / Revision	By
6.	2019-08-08	Addendum No. 01	LHT
5.	2019-07-08	Issued for Construction	LHT
4.	2019-06-26	Issued for 100% Pre-Tender Review	LHT
3.	2019-05-13	Issued for Pre-Tender Review	LHT
2.	2019-02-22	Design Development	LHT
1.	2018-12-17	Schematic Design Review	LHT

Drawn By: BKF
 Printing Date:

APEGM
 Certificate of Authorization
 Tower Engineering Group
 No. 4156 Expiry: April 30, 2020

500-136 Market Ave
 Winnipeg, Manitoba
 Canada R3B 0P4
 t: (204) 943.8671
 f: (204) 943.8676
 www.lm-architects.com

LM Architectural Group

Drawings and specifications, as instruments of service are the property of the architects, the copyright in the same being reserved to them. No reproduction may be made without the permission of the architects, and when made, must bear their names. All prints to be returned.
 The contractor is to verify dimensions and data noted herein with conditions on the site and is held responsible for reporting any discrepancy to the architects for adjustment.

Bill and Helen Norrie Library
 Project No.: 2017-082
 Tender No.: 542-2019
 Address: 15 Poseidon Bay, Winnipeg, MB.

Plan Details & Sections

Comm. No.: 1847
 Sheet: **S3.1R1**