



THE CITY OF WINNIPEG

TENDER

TENDER NO. 901-2019

SUPPLY AND DELIVERY OF HEAVY-DUTY 40 FT. LOW-FLOOR TRANSIT BUSES

TABLE OF CONTENTS

PART A - BID SUBMISSION

Form A: Bid	1
Form B: Prices	4

PART B - BIDDING PROCEDURES

B1. Contract Title	1
B2. Submission Deadline	1
B3. Enquiries	1
B4. Confidentiality	1
B5. Addenda	1
B6. Substitutes	2
B7. Bid Submission	3
B8. Bid	3
B9. Prices	4
B10. Disclosure	5
B11. Conflict of Interest and Good Faith	5
B12. Qualification	6
B13. Opening of Bids and Release of Information	7
B14. Irrevocable Bid	7
B15. Withdrawal of Bids	7
B16. Evaluation of Bids	8
B17. Award of Contract	8

PART C - GENERAL CONDITIONS

C0. General Conditions	1
------------------------	---

PART D - SUPPLEMENTAL CONDITIONS

General

D1. General Conditions	1
D2. Scope of Work	1
D3. Cooperative Purchase	5
D4. Definitions	6
D5. Contract Administrator	6
D6. Ownership of Information, Confidentiality and Non Disclosure	6
D7. Notices	6

Submissions

D8. Authority to Carry on Business	6
D9. Insurance	7
D10. Safety Data Sheets	7

Schedule of Work

D11. Commencement	7
D12. Delivery	8
D13. Liquidated Damages	8
D14. Orders	8
D15. Records	8

Measurement and Payment

D16. Invoices	9
D17. Payment	9
D18. Documentation	9
D19. Parts Availability Guarantee	10

Warranty

D20. Warranty	10
---------------	----

PART E - SPECIFICATIONS

General

E1. Applicable Specifications and Drawings	1
E2. Goods	1
E3. Inspections and Performance Tests	79

PART B - BIDDING PROCEDURES

B1. CONTRACT TITLE

B1.1 SUPPLY AND DELIVERY OF HEAVY-DUTY 40 FT. LOW-FLOOR TRANSIT BUSES

B2. SUBMISSION DEADLINE

B2.1 The Submission Deadline is 4:00 p.m. Winnipeg time, February 14, 2020.

B2.2 Bids determined by the Manager of Materials to have been received later than the Submission Deadline will not be accepted and will be returned upon request.

B2.3 The Contract Administrator or the Manager of Materials may extend the Submission Deadline by issuing an addendum at any time prior to the time and date specified in B2.1.

B3. ENQUIRIES

B3.1 All enquiries shall be directed to the Contract Administrator identified in D5.1.

B3.2 If the Bidder finds errors, discrepancies or omissions in the Tender, or is unsure of the meaning or intent of any provision therein, the Bidder shall promptly notify the Contract Administrator of the error, discrepancy or omission at least five (5) Business Days prior to the Submission Deadline.

B3.3 Responses to enquiries which, in the sole judgment of the Contract Administrator, require a correction to or a clarification of the Tender will be provided by the Contract Administrator to all Bidders by issuing an addendum.

B3.4 Responses to enquiries which, in the sole judgment of the Contract Administrator, do not require a correction to or a clarification of the Tender will be provided by the Contract Administrator only to the Bidder who made the enquiry.

B3.5 The Bidder shall not be entitled to rely on any response or interpretation received pursuant to B3 unless that response or interpretation is provided by the Contract Administrator in writing.

B4. CONFIDENTIALITY

B4.1 Information provided to a Bidder by the City or acquired by a Bidder by way of further enquiries or through investigation is confidential. Such information shall not be used or disclosed in any way without the prior written authorization of the Contract Administrator. The use and disclosure of the confidential information shall not apply to information which:

- (a) was known to the Bidder before receipt hereof; or
- (b) becomes publicly known other than through the Bidder; or
- (c) is disclosed pursuant to the requirements of a governmental authority or judicial order.

B4.2 The Bidder shall not make any statement of fact or opinion regarding any aspect of the Tender to the media or any member of the public without the prior written authorization of the Contract Administrator.

B5. ADDENDA

B5.1 The Contract Administrator may, at any time prior to the Submission deadline, issue addenda correcting errors, discrepancies or omissions in the Tender, or clarifying the meaning or intent of any provision therein.

- B5.2 The Contract Administrator will issue each addendum at least two (2) Business Days prior to the Submission Deadline, or provide at least two (2) Business Days by extending the Submission Deadline.
- B5.3 Addenda will be available on the Bid Opportunities page at The City of Winnipeg, Corporate Finance, Materials Management Division website at <http://www.winnipeg.ca/matmgt/bidopp.asp>
- B5.4 The Bidder is responsible for ensuring that he/she has received all addenda and is advised to check the Materials Management Division website for addenda regularly and shortly before the Submission Deadline, as may be amended by addendum.
- B5.5 The Bidder shall acknowledge receipt of each addendum in Paragraph 8 of Form A: Bid. Failure to acknowledge receipt of an addendum may render a Bid non-responsive.
- B5.6 Notwithstanding B3, enquiries related to an Addendum may be directed to the Contract Administrator indicated in D5.

B6. SUBSTITUTES

- B6.1 The Work is based on the materials, equipment, methods and products specified in the Tender.
- B6.2 Substitutions shall not be allowed unless application has been made to and prior approval has been granted by the Contract Administrator in writing.
- B6.3 Requests for approval of a substitute will not be considered unless received in writing by the Contract Administrator at least seven (7) Business Days prior to the Submission Deadline.
- B6.4 The Bidder shall ensure that any and all requests for approval of a substitute:
- (a) provide sufficient information and details to enable the Contract Administrator to determine the acceptability of the material, equipment, method or product as either an approved equal or alternative;
 - (b) identify any and all changes required in the applicable Work, and all changes to any other Work, which would become necessary to accommodate the substitute;
 - (c) identify any anticipated cost or time savings that may be associated with the substitute;
 - (d) certify that, in the case of a request for approval as an approved equal, the substitute will fully perform the functions called for by the general design, be of equal or superior substance to that specified, is suited to the same use and capable of performing the same function as that specified and can be incorporated into the Work, strictly in accordance with the Contract;
 - (e) certify that, in the case of a request for approval as an approved alternative, the substitute will adequately perform the functions called for by the general design, be similar in substance to that specified, is suited to the same use and capable of performing the same function as that specified and can be incorporated into the Work, strictly in accordance with the Contract.
- B6.5 The Contract Administrator, after assessing the request for approval of a substitute, may in his/her sole discretion grant approval for the use of a substitute as an “approved equal” or as an “approved alternative”, or may refuse to grant approval of the substitute.
- B6.6 The Contract Administrator will provide a response in writing, at least two (2) Business Days prior to the Submission Deadline, to the Bidder who requested approval of the substitute.
- B6.6.1 The Contract Administrator will issue an Addendum, disclosing the approved materials, equipment, methods and products to all potential Bidders. The Bidder requesting and obtaining the approval of a substitute shall be responsible for disseminating information regarding the approval to any person or persons he/she wishes to inform.

- B6.7 If the Contract Administrator approves a substitute as an “approved equal”, any Bidder may use the approved equal in place of the specified item.
- B6.8 If the Contract Administrator approves a substitute as an “approved alternative”, any Bidder bidding that approved alternative may base his/her Total Bid Price upon the specified item but may also indicate an alternative price based upon the approved alternative. Such alternatives will be evaluated in accordance with B16.
- B6.9 No later claim by the Contractor for an addition to the price(s) because of any other changes in the Work necessitated by the use of an approved equal or an approved alternative will be considered.

B7. BID SUBMISSION

- B7.1 The Bid shall consist of the following components:
- (a) Form A: Bid;
 - (b) Form B: Prices.
- B7.2 Further to B7.1, the Bidder should include the written correspondence from the Contract Administrator approving a substitute in accordance with B6.
- B7.3 All components of the Bid shall be fully completed or provided, and submitted by the Bidder no later than the Submission Deadline, with all required entries made clearly and completely.
- B7.4 The Bid Submission may be submitted by mail, courier or personal delivery, or by facsimile transmission.
- B7.5 If the Bid Submission is submitted by mail, courier or personal delivery, it shall be enclosed and sealed in an envelope clearly marked with the Tender number and the Bidder's name and address, and shall be submitted to:
- The City of Winnipeg
Corporate Finance Department
Materials Management Division
185 King Street, Main Floor
Winnipeg MB R3B 1J1
- B7.5.1 Samples or other components of the Bid Submission which cannot reasonably be enclosed in the envelope may be packaged separately, but shall be clearly marked with the Tender number, the Bidder's name and address, and an indication that the contents are part of the Bidder's Bid Submission.
- B7.6 If the Bid Submission is submitted by facsimile transmission, it shall be submitted to 204- 949-1178.
- B7.6.1 The Bidder is advised that the City cannot take responsibility for the availability of the facsimile machine at any time or guarantee the successful receipt of a faxed Bid Submission.
- B7.7 Bidders are advised not to include any information/literature except as requested in accordance with B7.1.
- B7.8 Bidders are advised that inclusion of terms and conditions inconsistent with the Tender document, including the General Conditions, will be evaluated in accordance with B16.1(a).
- B7.9 Bids submitted by internet electronic mail (e-mail) will not be accepted.

B8. BID

- B8.1 The Bidder shall complete Form A: Bid, making all required entries.

- B8.2 Paragraph 2 of Form A: Bid shall be completed in accordance with the following requirements:
- (a) if the Bidder is a sole proprietor carrying on business in his/her own name, his/her name shall be inserted;
 - (b) if the Bidder is a partnership, the full name of the partnership shall be inserted;
 - (c) if the Bidder is a corporation, the full name of the corporation shall be inserted;
 - (d) if the Bidder is carrying on business under a name other than his/her own, the business name and the name of every partner or corporation who is the owner of such business name shall be inserted.
- B8.2.1 If a Bid is submitted jointly by two or more persons, each and all such persons shall identify themselves in accordance with B8.2.
- B8.3 In Paragraph 3 of Form A: Bid, the Bidder shall identify a contact person who is authorized to represent the Bidder for purposes of the Bid.
- B8.4 Paragraph 11 of Form A: Bid shall be signed in accordance with the following requirements:
- (a) if the Bidder is a sole proprietor carrying on business in his/her own name, it shall be signed by the Bidder;
 - (b) if the Bidder is a partnership, it shall be signed by the partner or partners who have authority to sign for the partnership;
 - (c) if the Bidder is a corporation, it shall be signed by its duly authorized officer or officers;
 - (d) if the Bidder is carrying on business under a name other than his/her own, it shall be signed by the registered owner of the business name, or by the registered owner's authorized officials if the owner is a partnership or a corporation.
- B8.4.1 The name and official capacity of all individuals signing Form A: Bid should be printed below such signatures.
- B8.5 If a Bid is submitted jointly by two or more persons, the word "Bidder" shall mean each and all such persons, and the undertakings, covenants and obligations of such joint Bidders in the Bid and the Contract, when awarded, shall be both joint and several.

B9. PRICES

- B9.1 The Bidder shall state a price in Canadian funds for each item of the Work identified on Form B: Prices.
- B9.1.1 Prices on Form B: Prices shall include:
- (a) duty;
 - (b) freight and cartage;
 - (c) Provincial and Federal taxes [except the Goods and Services Tax (GST) and Manitoba Retail Sales Tax (MRST, also known as PST), which shall be extra where applicable] and all charges governmental or otherwise paid;
 - (d) profit and all compensation which shall be due to the Contractor for the Work and all risks and contingencies connected therewith.
- B9.1.2 Prices on Form B: Prices shall not include Environmental Handling Charges (EHC) or fees, which shall be extra where applicable.
- B9.2 The quantities listed on Form B: Prices are to be considered approximate only. The City will use said quantities for the purpose of comparing Bids.
- B9.3 The quantities for which payment will be made to the Contractor are to be determined by the Work actually performed and completed by the Contractor, to be measured as specified in the applicable Specifications.

B10. DISCLOSURE

B10.1 Various Persons provided information or services with respect to this Work. In the City's opinion, this relationship or association does not create a conflict of interest because of this full disclosure. Where applicable, additional material available as a result of contact with these Persons is listed below.

B10.2 The Persons are:

- (a) N/A.

B11. CONFLICT OF INTEREST AND GOOD FAITH

B11.1 Bidders, by responding to this Tender, declare that no Conflict of Interest currently exists, or is reasonably expected to exist in the future.

B11.2 Conflict of Interest means any situation or circumstance where a Bidder or employee of the Bidder proposed for the Work has:

- (a) other commitments;
- (b) relationships;
- (c) financial interests; or
- (d) involvement in ongoing litigation;

that could or would be seen to:

- (i) exercise an improper influence over the objective, unbiased and impartial exercise of the independent judgment of the City with respect to the evaluation of Bids or award of the Contract; or
- (ii) compromise, impair or be incompatible with the effective performance of a Bidder's obligations under the Contract;
- (e) has contractual or other obligations to the City that could or would be seen to have been compromised or impaired as a result of its participation in the Tender process or the Work; or
- (f) has knowledge of confidential information (other than confidential information disclosed by the City in the normal course of the Tender process) of strategic and/or material relevance to the Tender process or to the Work that is not available to other bidders and that could or would be seen to give that Bidder an unfair competitive advantage.

B11.3 In connection with its Bid, each entity identified in B11.2 shall:

- (a) avoid any perceived, potential or actual Conflict of Interest in relation to the procurement process and the Work;
- (b) upon discovering any perceived, potential or actual Conflict of Interest at any time during the Tender process, promptly disclose a detailed description of the Conflict of Interest to the City in a written statement to the Contract Administrator; and
- (c) provide the City with the proposed means to avoid or mitigate, to the greatest extent practicable, any perceived, potential or actual Conflict of Interest and shall submit any additional information to the City that the City considers necessary to properly assess the perceived, potential or actual Conflict of Interest.

B11.4 Without limiting B11.3, the City may, in its sole discretion, waive any and all perceived, potential or actual Conflicts of Interest. The City's waiver may be based upon such terms and conditions as the City, in its sole discretion, requires to satisfy itself that the Conflict of Interest has been appropriately avoided or mitigated, including requiring the Bidder to put into place such policies, procedures, measures and other safeguards as may be required by and be acceptable to the City, in its sole discretion, to avoid or mitigate the impact of such Conflict of Interest.

- B11.5 Without limiting B11.3, and in addition to all contractual or other rights or rights at law or in equity or legislation that may be available to the City, the City may, in its sole discretion:
- (a) disqualify a Bidder that fails to disclose a perceived, potential or actual Conflict of Interest of the Bidder or any of its employees proposed for the Work;
 - (b) require the removal or replacement of any employees proposed for the Work that has a perceived, actual or potential Conflict of Interest that the City, in its sole discretion, determines cannot be avoided or mitigated;
 - (c) disqualify a Bidder or employees proposed for the Work that fails to comply with any requirements prescribed by the City pursuant to B11.4 to avoid or mitigate a Conflict of Interest; and
 - (d) disqualify a Bidder if the Bidder, or one of its employees proposed for the Work, has a perceived, potential or actual Conflict of Interest that, in the City's sole discretion, cannot be avoided or mitigated, or otherwise resolved.

B11.6 The final determination of whether a perceived, potential or actual Conflict of Interest exists shall be made by the City, in its sole discretion.

B12. QUALIFICATION

B12.1 The Bidder shall:

- (a) undertake to be in good standing under The Corporations Act (Manitoba), or properly registered under The Business Names Registration Act (Manitoba), or otherwise properly registered, licensed or permitted by law to carry on business in Manitoba, or if the Bidder does not carry on business in Manitoba, in the jurisdiction where the Bidder does carry on business; and
- (b) be financially capable of carrying out the terms of the Contract; and
- (c) have all the necessary experience, capital, organization, and equipment to perform the Work in strict accordance with the terms and provisions of the Contract.

B12.2 The Bidder and any proposed Subcontractor (for the portion of the Work proposed to be subcontracted to them) shall:

- (a) be responsible and not be suspended, debarred or in default of any obligations to the City. A list of suspended or debarred individuals and companies is available on the Information Connection page at The City of Winnipeg, Corporate Finance, Materials Management Division website at <https://winnipeg.ca/finance/findata/matmgt/listing/debar.pdf>

B12.3 The Bidder and/or any proposed Subcontractor (for the portion of the Work proposed to be subcontracted to them) shall:

- (a) have successfully carried out work similar in nature, scope and value to the Work; and
- (b) be fully capable of performing the Work required to be in strict accordance with the terms and provisions of the Contract; and
- (c) have a written workplace safety and health program, if required, pursuant to The Workplace Safety and Health Act (Manitoba).

B12.4 The Bidder shall submit, within three (3) Business Days of a request by the Contract Administrator, proof satisfactory to the Contract Administrator of the qualifications of the Bidder and of any proposed Subcontractor. **This proof may include, but is not limited to, a listing of three hundred (300) previous sales of transit low-floor diesel buses capable of consistent top performance in the same climate weather conditions as the City of Winnipeg, including a specific contact person that is knowledgeable about the specified bus model and STURAA test results.**

- (a) **Note: City of Winnipeg has four seasons with ambient temperatures ranging from approximately 32°C (90°F) to -40°C (-40°F).**

B12.5 The Bidder shall provide, on the request of the Contract Administrator, full access to any of the Bidder's equipment and facilities to confirm, to the Contract Administrator's satisfaction, that the Bidder's equipment and facilities are adequate to perform the Work.

B13. OPENING OF BIDS AND RELEASE OF INFORMATION

B13.1 Bids will not be opened publicly.

B13.2 Following the Submission Deadline, the names of the Bidders and their Total Bid Prices (unevaluated, and pending review and verification of conformance with requirements or evaluated prices) will be available on the Closed Bid Opportunities (or Public/Posted Opening & Award Results) page at The City of Winnipeg, Corporate Finance, Materials Management Division website at <http://www.winnipeg.ca/matmgt>

B13.3 After award of Contract, the name(s) of the successful Bidder(s), their address(es) and the Contract amount(s) will be available on the Closed Bid Opportunities (or Public/Posted Opening & Award Results) page at The City of Winnipeg, Corporate Finance, Materials Management Division website at <http://www.winnipeg.ca/matmgt>

B13.4 The Bidder is advised that any information contained in any Bid may be released if required by The Freedom of Information and Protection of Privacy Act (Manitoba), by other authorities having jurisdiction, or by law or by City policy or procedures (which may include access by members of City Council).

B13.4.1 To the extent permitted, the City shall treat as confidential information, those aspects of a Bid Submission identified by the Bidder as such in accordance with and by reference to Part 2, Section 17 or Section 18 or Section 26 of The Freedom of Information and Protection of Privacy Act (Manitoba), as amended.

B14. IRREVOCABLE BID

B14.1 The Bid(s) submitted by the Bidder shall be irrevocable for the time period specified in Paragraph 9 of Form A: Bid.

B14.2 The acceptance by the City of any Bid shall not release the Bids of the next two lowest evaluated responsive Bidders and these Bidders shall be bound by their Bids on such Work for the time period specified in Paragraph 9 of Form A: Bid.

B15. WITHDRAWAL OF BIDS

B15.1 A Bidder may withdraw his/her Bid without penalty by giving written notice to the Manager of Materials at any time prior to the Submission Deadline.

B15.1.1 Notwithstanding C21, the time and date of receipt of any notice withdrawing a Bid shall be the time and date of receipt as determined by the Manager of Materials.

B15.1.2 The City will assume that any one of the contact persons named in Paragraph 3 of Form A: Bid or the Bidder's authorized representatives named in Paragraph 11 of Form A: Bid, and only such person, has authority to give notice of withdrawal.

B15.1.3 If a Bidder gives notice of withdrawal prior to the Submission Deadline, the Manager of Materials will:

- (a) retain the Bid until after the Submission Deadline has elapsed;
- (b) open the Bid to identify the contact person named in Paragraph 3 of Form A: Bid and the Bidder's authorized representatives named in Paragraph 11 of Form A: Bid; and
- (c) if the notice has been given by any one of the persons specified in B15.1.3(b), declare the Bid withdrawn.

B15.2 A Bidder who withdraws his/her Bid after the Submission Deadline but before his/her Bid has been released or has lapsed as provided for in B14.2 shall be liable for such damages as are imposed upon the Bidder by law and subject to such sanctions as the Chief Administrative Officer considers appropriate in the circumstances. The City, in such event, shall be entitled to all rights and remedies available to it at law.

B16. EVALUATION OF BIDS

B16.1 Award of the Contract shall be based on the following bid evaluation criteria:

- (a) compliance by the Bidder with the requirements of the Tender, or acceptable deviation therefrom (pass/fail);
- (b) qualifications of the Bidder and the Subcontractors, if any, pursuant to B12 (pass/fail);
- (c) Total Bid Price;
- (d) economic analysis of any approved alternative pursuant to B6.

B16.2 Further to B16.1(a), the Award Authority may reject a Bid as being non-responsive if the Bid Submission is incomplete, obscure or conditional, or contains additions, deletions, alterations or other irregularities. The Award Authority may reject all or any part of any Bid, or waive technical requirements or minor informalities or irregularities if the interests of the City so require.

B16.3 Further to B16.1(b), the Award Authority shall reject any Bid submitted by a Bidder who does not demonstrate, in his/her Bid or in other information required to be submitted, that he/she is qualified.

B16.4 Further to B16.1(c), the Total Bid Price shall be the sum of the quantities multiplied by the unit prices for each item shown on Form B: Prices.

B16.4.1 Further to B16.1(a), in the event that a unit price is not provided on Form B: Prices, the City may determine the unit price by dividing the Amount (extended price) by the approximate quantity, for the purposes of evaluation and payment.

B16.5 This Contract will be awarded as a whole.

B17. AWARD OF CONTRACT

B17.1 The City will give notice of the award of the Contract or will give notice that no award will be made.

B17.2 The City will have no obligation to award a Contract to a Bidder, even though one or all of the Bidders are determined to be qualified, and the Bids are determined to be responsive.

B17.2.1 Without limiting the generality of B17.2, the City will have no obligation to award a Contract where:

- (a) the prices exceed the available City funds for the Work;
- (b) the prices are materially in excess of the prices received for similar work in the past;
- (c) the prices are materially in excess of the City's cost to perform the Work, or a significant portion thereof, with its own forces;
- (d) only one Bid is received; or
- (e) in the judgment of the Award Authority, the interests of the City would best be served by not awarding a Contract.

B17.3 Where an award of Contract is made by the City, the award shall be made to the qualified Bidder submitting the lowest evaluated responsive Bid, in accordance with B16.

B17.3.1 Following the award of contract, a Bidder will be provided with information related to the evaluation of his/her Bid upon written request to the Contract Administrator.

- B17.4 Notwithstanding C4, the City may issue a purchase order to the successful Bidder in lieu of the execution of a Contract.
- B17.5 The Contract Documents, as defined in C1.1(n)(ii), in their entirety shall be deemed to be incorporated in and to form a part of the purchase order notwithstanding that they are not necessarily attached to or accompany said purchase order.

PART C - GENERAL CONDITIONS

C0. GENERAL CONDITIONS

- C0.1 The *General Conditions for the Supply of Goods* (Revision 2019-01-15) are applicable to the Work of the Contract.
- C0.1.1 The *General Conditions for the Supply of Goods* are available on the Information Connection page at The City of Winnipeg, Corporate Finance, Materials Management Division website at http://www.winnipeg.ca/matmgt/gen_cond.stm
- C0.2 A reference in the Tender to a section, clause or subclause with the prefix "**C**" designates a section, clause or subclause in the *General Conditions for Supply of Goods*.

PART D - SUPPLEMENTAL CONDITIONS

GENERAL

D1. GENERAL CONDITIONS

D1.1 In addition to the *General Conditions for the Supply of Goods*, these Supplemental Conditions are applicable to the Work of the Contract.

D2. SCOPE OF WORK

D2.1 The Work to be done under the Contract shall consist of supply and delivery of low-floor Transit diesel buses for the period from the date of award until May 31, 2021, with the option of five (5) mutually agreed upon one (1) year extensions.

(a) Each one (1) year extension it is anticipated that the City may purchase approximately thirty-five (35) 40 ft. low-floor transit diesel buses.

D2.1.1 The City may negotiate the extension option with the Contractor within ninety (90) Calendar Days prior to the expiry date of the Contract. The City shall incur no liability to the Contractor as a result of such negotiations.

D2.1.2 Changes resulting from such negotiations shall become effective on June 1st of the respective year. Changes to the Contract shall not be implemented by the Contractor without written approval by the Contract Administrator.

D2.2 Prices for each extension renewal terms are to be adjusted based on the following:

- (a) Annual price adjustment for inflation to be no greater than that indicated in Statistics Canada Monthly Industrial Product Price Index Table 18-10-0032-01 (formerly CANSIM 329-0077): Heavy-duty truck manufacturing (33612). The price adjustment is calculated as the percentage change in the average of the monthly index within the previous two (2) years.
- (b) Price adjustment for government mandated build changes or environmental enhancements to be demonstrably equivalent to or lower than competitor manufacturers, for the class of unit.
- (c) Price adjustment for technological improvements to be justifiable on a life cost basis and demonstrably equivalent to or lower than competitor manufacturers, for the class of unit.

D2.3 The City reserves the right to replace some or all of the purchase of 40 ft. Low-Floor buses with 60 ft. Articulated Diesel Low-Floor Transit Buses in any of the mutually agreed upon extensions.

D2.4 Notwithstanding D2.1, the type and quantity of Work to be performed under this Contract is subject to annual approval of monies therefore in a budget by Council. Bidders are advised that monies have been approved for work up to and including December 31, 2019.

D2.4.1 In the event that Council does not approve the annual budget for any year during this Contract, the City reserves the right to alter the type or quantity of work performed under this Contract, or to terminate the Contract, upon one hundred and twenty (120) Calendar Days written notice by the Contract Administrator. In such an event, no claim may be made against the City for damages of any kind resulting from the termination, including, but not limited to, on the ground of loss of anticipated profit on Work.

D2.5 Notwithstanding D2.1, in the event that operational changes result in substantial changes to the requirements for Work, the City reserves the right to alter the type or quantity of work performed under this Contract, or to terminate the Contract, upon thirty (30) Calendar Days written notice by the Contract Administrator. In such an event, no claim may be made for damages on the ground of loss of anticipated profit on Work.

D2.6 Referencing APTA Guideline SP 2.3 Contract Deliverables:

(a) **Contract deliverables associated with this Contract are set forth in the table below, along with other pertinent information. Contract deliverables shall be submitted in accordance with E1. Due dates shown note the last acceptable date for receipt of Contract deliverables. All documents must be acceptable to the City. All parts and service corrections must be made, on the master electronic copy, within 30 Calendar Days of notice. The electronic corrections must be followed by all hardcopy updates within 90 Calendar Days of notice. The City will consider early receipt of Contract deliverables on a case-by-case basis. The reference section designates the appropriate specification section(s) where the requirement is referenced.**

(b) Contract Deliverables:

Deliverable	Due Date	Format	Quantity Due
Material samples	Pre-production meeting		1
Undercoating system program	Pre-production meeting	Electronic	1
Technical review of electronic functionality	Pre-production meeting	Hardcopy Electronic	1 1
Interior security camera layout	Pre-production meeting	Electronic	1
Technical review of power plant	Pre-production meeting	Electronic	1
Engineering support	Pre-production meeting	Contracts	1
List of OEM component repair manuals	Pre-production Meeting	Hardcopy	1
Warranty Documents	Pre-production meeting.	Electronic	1
Training – 100 instructor hours per contract year	Hours accumulate until used or otherwise expensed by the city.		100 hours
Pre-production meeting minutes	15 Calendar Days after each meeting	Electronic	2 originals
Recommended spare parts list	30 Calendar Days prior to pilot bus	Electronic	1
Part number index	30 Calendar Days prior to pilot bus	Electronic	1
Current price list	30 Calendar Days prior to pilot bus	Electronic	1
Striping layout	30 Calendar Days prior to pilot bus	Hardcopy	1
Resolution of issues “subject to City approval”	30 Calendar Days prior to pilot bus	Hardcopy	1
Preliminary Parts & Service Manual	With pilot bus	Electronic	1

All OEM manuals (including but not limited to engine, transmission, passenger seating, HVAC, wiring/harness connectors, etc.)	With pilot bus	Hardcopy Electronic	3 1
Complete Engineering Bill of Material.	With pilot bus	Electronic	1
List of OEM electrical connectors (pins, seals, locks, etc.	With pilot bus	Electronic	1
Preliminary Electrical and air schematics	With pilot bus	Electronic	1
Glazing drawings/spec for all window glass on the bus	With pilot bus	Electronic	1
Current index file displaying all Part Numbers, description, manual location, Build #.	With pilot bus	Electronic	1
Engine Emissions Certificate — NOx levels	With pilot bus	Hardcopy	1
List of serialized units installed on each bus	With each bus	Electronic	1 per bus
QA manufacturing certificate	With each bus	Hardcopy	1 per bus
Pre-Delivery Bus Documentation Package	With each delivered bus	Hardcopy	1 per bus
Motor Vehicle Pollution Requirements Certificate	With each bus	Hardcopy	1
Operator's log and incident report	With each bus	Hardcopy	1 per bus
Title documentation	With each bus	Hardcopy	1 per bus
As-built drawings	Within 60 Calendar Days after final bus delivery	Electronic Media	1
Final Manuals - current service manual(s) to include preventative maintenance procedures, diagnostic procedures or trouble-shooting guides and major component service manuals, current parts manual(s) including component parts, and standard operator's manual(s),	90 Calendar Days after pilot bus	Hardcopy Electronic	7per build 1

Final electronic and air schematics in 11 x 17 3-hole plastic paper.		Hardcopy Electronic	6 per build 1
All electronic software	To be held in escrow	Electronic	1 Each
Bus Supplier / OEM Part Number Cross-reference, including OEM identification and contact information	90 Calendar Days after pilot bus	Electronic	1 Each
All full versions of diagnostic and programming software, licenses and necessary patch cables and associated hardware for all vehicle sub-systems	90 Calendar Days after pilot bus	Hardcopy Electronic Patch cable	1 10 per build 10

D2.7 Referencing APTA Guideline SP 1.2 Pilot Bus:

- (a) The Contractor shall produce one pilot vehicle for each type of vehicle with respect to the base order. This vehicle shall be one of the ultimate quantity of the base vehicle order. The pilot vehicle shall demonstrate that the vehicles fully meet all requirements of the Contract. The pilot vehicle shall be produced and delivered to the City for a minimum of thirty (30) Calendar Days prior to initiation of any production activities for the remaining vehicles unless otherwise authorized in writing by the City.

D2.8 At the City's request and subject to the Contractor's build schedule, the Contractor may remove the pilot vehicle if any or all extensions that are similar build as the previous order.

D2.9 In the event that the pilot vehicle does not initially comply with all performance criteria contained in the Technical Specifications, the City shall have the right to retain 5% of any payment that may have been established for the pilot vehicle. This amount shall be withheld until compliance is demonstrated. In the event that the compliance is subsequently determined to be impossible to achieve, the City may require all or a portion of the payment for the pilot vehicle to be forfeited as a penalty for the noncompliance. The amount of the penalty shall be negotiated by the parties.

D2.10 Referencing APTA Guideline SP 1.3 Configuration and Performance Approval:

- (a) In order to assess the Contractor's compliance with the Technical Specifications, the City and the Contractor shall, at the Pre-Production Meeting, jointly develop a configuration and performance review document for review of the pilot vehicle. This document shall include appropriate performance standards for each test that is being required and the document shall become part of the official record of the pre-production meeting.

D2.11 Referencing APTA Guideline SP 1.4 First Article Inspection – Production:

- (a) The purpose of a first article inspection is to confirm that any components, systems, subsystems, major assemblies, subassemblies, products, parts, apparatuses, articles and other materials comply with the Technical Specifications and other Contract documents.
- (b) Where required by the Contract documents or requested by the City, the Contractor shall cause first article inspections to be conducted. A first article inspection may include both a physical configuration inspection and a functional demonstration. First article inspections shall be conducted at the Contractor or Subcontractor's facility. The Contractor shall furnish to the City prior to each first article inspection a written inspection and demonstration plan for each item for review. The City's inspectors will attend each first article inspection unless the City provides a written waiver of its right to attend any such inspection. The results of each first article inspection shall be documented by the Contractor in a format deemed

acceptable by the City, and all documents relating to the inspection shall be forwarded to the City.

D2.12 Referencing APTA Guideline SP 1.4 Post-Delivery Tests:

- (a) The City will conduct acceptance tests on each delivered bus. These tests shall be completed within fifteen (15) Calendar Days after bus delivery and shall be conducted in accordance with written test plans. The purpose of these tests is to identify Defects that have become apparent between the time of bus release and delivery to the City. The post-delivery tests shall include visual inspection and bus operations. No post-delivery test shall apply criteria that are different from the criteria applied in an analogous pre- delivery test (if any).
- (b) Buses that fail to pass the post-delivery tests are subject to non-acceptance. The City shall record details of all Defects on the appropriate test forms and shall notify the Contractor of acceptance or non-acceptance of each bus according to "Inspection, Testing and Acceptance" after completion of the tests. The Defects detected during these tests shall be repaired according to procedures defined in "Repairs after Non- Acceptance."

D2.13 Referencing APTA Guideline SP 1.6 Repairs after Non-Acceptance:

- (a) The Contractor, or its designated representative, shall perform the repairs after non-acceptance within five (5) Business Days.**

D3. COOPERATIVE PURCHASE

D3.1 The Contractor is advised that this is a cooperative purchase.

D3.2 The Contract Administrator may, from time to time during the term of the Contract, approve other public sector organizations and utilities, including but not limited to municipalities, universities, schools and hospitals, to be participants in the cooperative purchase.

D3.3 The Contract Administrator will notify the Contractor of a potential participant and provide a list of the delivery locations and estimated quantities.

D3.4 If any location of the potential participant is more than ten (10) kilometers beyond the boundaries of the City of Winnipeg, the Contractor shall, within fifteen (15) Calendar Days of the written notice, notify the Contract Administrator of the amount of any additional delivery charge for the location.

D3.5 If any additional delivery charges are identified by the Contractor, the potential participant may accept or decline to participate in the cooperative purchase.

D3.6 The Contractor shall enter into a contract with each participant under the same terms and conditions as this Contract except:

- (a) supply under the contract shall not commence until the expiry or lawful termination of any other contract(s) binding the participant for the same goods;
- (b) a participant may specify a duration of Contract shorter than the duration of this Contract;
- (c) a participant may specify that only some items under this Contract and/or less than its total requirement for an item are to be supplied under its contract; and
- (d) any additional delivery charge identified and accepted in accordance with clause D3.4 and D3.5 will apply.

D3.7 Each participant will be responsible for the administration of its contract and the fulfilment of its obligations under its contract. The City shall not incur any liability arising from any such contract.

D3.8 No participant shall have the right or authority to effect a change in the Contract, or of any other participant in this Contract.

D4. DEFINITIONS

D4.1 When used in this Tender:

- (a) **"Business Day"** means any Calendar Day, other than a Saturday, Sunday or a Statutory or Civic Holiday;
- (b) **"Submission Deadline" and "Time and Date Set for the Final Receipt of bids"** means the time and date set out in the Bidding Procedures for final receipt of Bids;
- (c) **"Coach Down"** means a vehicle unavailable for regular revenue service as a result of unavailable parts and/or repair procedure;
- (d) **"APTA Guideline"** means the Standard Bus Procurement Guidelines RFP as published by the American Public Transit Association (APTA).

D5. CONTRACT ADMINISTRATOR

D5.1 The Contract Administrator is:

Jim Pearce
Superintendent of Vehicle Overhaul
City of Winnipeg Transit Department
Telephone No.: 204- 986-5801
Email Address: jpearce@winnipeg.ca

D6. OWNERSHIP OF INFORMATION, CONFIDENTIALITY AND NON DISCLOSURE

D6.1 The Contract, all deliverables produced or developed, and information provided to or acquired by the Contractor are the property of the City and shall not be appropriated for the Contractors own use, or for the use of any third party.

D6.2 The Contractor shall not make any public announcements or press releases regarding the Contract, without the prior written authorization of the Contract Administrator.

D6.3 The following shall be confidential and shall not be disclosed by the Contractor to the media or any member of the public without the prior written authorization of the Contract Administrator;

- (a) information provided to the Contractor by the City or acquired by the Contractor during the course of the Work;
- (b) the Contract, all deliverables produced or developed; and
- (c) any statement of fact or opinion regarding any aspect of the Contract.

D6.4 A Contractor who violates any provision of D6 may be determined to be in breach of Contract.

D7. NOTICES

D7.1 Notwithstanding C21.3, all notices of appeal to the Chief Administrative Officer shall be sent to the attention of the Chief Financial Officer.

SUBMISSIONS

D8. AUTHORITY TO CARRY ON BUSINESS

D8.1 The Contractor shall be in good standing under The Corporations Act (Manitoba), or properly registered under The Business Names Registration Act (Manitoba), or otherwise properly registered, licensed or permitted by law to carry on business in Manitoba, or if the Contractor does not carry on business in Manitoba, in the jurisdiction where the Contractor does carry on business, throughout the term of the Contract, and shall provide the Contract Administrator with evidence thereof upon request.

D9. INSURANCE

- D9.1 The Contractor shall provide and maintain the following insurance coverage:
- (a) commercial general liability insurance, in the amount of at least five million dollars (\$5,000,000.00) per occurrence limit and five million dollar (\$5,000,000) aggregate, with The City of Winnipeg added as an additional insured; such liability policy to also contain a cross-liability clause, **contractual liability clause**, non-owned automobile liability and products and completed operations cover, to remain in place at all times during the performance of the Work;
 - (b) **either the Contractor or the sub-contractor hired for the delivery of the buses, shall provide evidence of Automobile Liability Insurance insuring the buses while being driven to 421 Osborne Street, Winnipeg , MB.** The Limit of Liability shall not be less than \$5,000,000 for loss or damage including personal injuries and death resulting from any one accident or occurrence.
- D9.2 Deductibles shall be borne by the Contractor.
- D9.3 The Contractor shall provide the Contract Administrator with a certificate(s) of insurance, in a form satisfactory to the City Solicitor, at least two (2) Business Days prior to the commencement of any Work but in no event later than the date specified in C4 for the return of the executed Contract.
- D9.4 The Contractor shall not cancel, materially alter, or cause the policy to lapse without providing at least thirty (30) Calendar Days prior written notice to the Contract Administrator.
- D9.5 The City shall have the right to alter the limits and/or coverages as reasonably required from time to time during the continuance of this agreement.

D10. SAFETY DATA SHEETS

- D10.1 The Contractor shall provide the Contract Administrator with one (1) copy of Safety Data Sheets (SDS's) for each product to be supplied under the Contract at least two (2) Business Days prior to the commencement of Work but in no event later than seven (7) Calendar Days from notification of the award of Contract.
- D10.2 Throughout the term of the Contract, the Contractor shall provide the Contract Administrator with revisions or updates of the SDS's as soon as may be reasonably possible.

SCHEDULE OF WORK

D11. COMMENCEMENT

- D11.1 The Contractor shall not commence any Work until he/she is in receipt of a notice of award from the City authorizing the commencement of the Work.
- D11.2 The Contractor shall not commence any Work until:
- (a) the Contract Administrator has confirmed receipt and approval of:
 - (i) evidence of authority to carry on business specified in D8;
 - (ii) evidence of the workers compensation coverage specified in C6.16;
 - (iii) evidence of the insurance specified in D9; and
 - (iv) the Safety Data Sheets specified in D10.
 - (b) the Contractor has attended a meeting with the Contract Administrator, or the Contract Administrator has waived the requirement for a meeting.

D12. DELIVERY

D12.1 Goods shall be delivered, according to the bus build schedule presented at the pre-production meeting, f.o.b. destination, freight prepaid to:

Jim Pearce
Winnipeg Transit Fort Rouge Transit Base
421 Osborne St.
Winnipeg, Manitoba
R3L 2A2

D12.2 The Contractor shall confirm each delivery with the Contract Administrator or his/her designate, at least two (2) Business Days before delivery.

D12.3 The buses shall be delivered at a rate not to exceed two (2) buses per week. Delivery shall be completed within fifty-two (52) weeks after delivery of the Purchase Order by the City of Winnipeg.

D12.4 Goods shall be delivered between 7:00 a.m. and 2:00 p.m. Monday to Friday excluding Statutory Holidays observed in the Province of Manitoba.

D12.5 The Contractor shall off-load goods as directed at the delivery location.

D12.6 Vehicle Identification Numbers (VIN) must be supplied for entire build at least 2 weeks prior to delivery of the pilot bus.

D12.7 Each bus must be delivered with all documentation necessary for licensing in the Province of Manitoba.

D13. LIQUIDATED DAMAGES

D13.1 If the Contractor fails to achieve delivery of the goods within the time specified in D12. Delivery the Contractor shall pay the City two hundred and fifty dollars (\$250.00) per each unaccepted bus per Calendar Day for each and every Calendar Day until the goods have been delivered.

D13.2 The amount specified for liquidated damages in D13.1 is based on a genuine pre-estimate of the City's damages in the event that the Contractor does not achieve delivery by the day fixed herein for same.

D13.3 The City may reduce any payment to the Contractor by the amount of any liquidated damages assessed.

D13.4 Liquidated Damages are to be adjusted annually by the Statistics Canada Monthly Industrial Product Price Index Table 18-10-0032-01 (formerly CANSIM 329-0077): Heavy-duty truck manufacturing (33612).

D14. ORDERS

D14.1 The Contractor shall provide a local Winnipeg telephone number or a toll-free telephone number at which orders for delivery may be placed.

D15. RECORDS

D15.1 The Contractor shall keep detailed records of the goods supplied under the Contract.

- D15.2 The Contractor shall record, as a minimum, for each item listed on Form B: Prices:
- (a) user name(s) and addresses;
 - (b) order date(s);
 - (c) delivery date(s); and
 - (d) description and quantity of goods supplied.
- D15.3 The Contractor shall provide the Contract Administrator with a copy of the records for each quarter year within fifteen (15) Calendar Days of a request of the Contract Administrator.

MEASUREMENT AND PAYMENT

D16. INVOICES

- D16.1 Further to C10, the Contractor shall submit an invoice for each order delivered to:
- The City of Winnipeg
Corporate Finance - Accounts Payable
4th Floor, Administration Building, 510 Main Street
Winnipeg MB R3B 1B9
- Facsimile No.: 204- 949-0864
Email: CityWpgAP@winnipeg.ca
- D16.2 Invoices must clearly indicate, as a minimum:
- (a) the City's purchase order number;
 - (b) date of delivery;
 - (c) delivery address;
 - (d) type and quantity of goods delivered;
 - (e) the amount payable with GST, MRST, and any applicable environmental handling charges/fees identified and shown as separate amounts; and
 - (f) the Contractor's GST registration number.
- D16.3 The City will bear no responsibility for delays in approval of invoices which are improperly submitted.
- D16.4 **Bid Submissions must not be submitted to the above facsimile numbers. Bids must be submitted in accordance with B7.**

D17. PAYMENT

- D17.1 Further to C10, payment shall be in Canadian funds net thirty (30) Calendar Days after receipt and approval of the Contractor's invoice.
- D17.2 Further to C10, the City may at its option pay the Contractor by direct deposit to the Contractor's banking institution.
- D17.3 The Contractor may offer early payment discounts relative to specified terms of payment. Acceptance of any discount off will be at the sole option of the City.

D18. DOCUMENTATION

- D18.1 Referencing APTA Guideline SP 7.2 Documentation:
- (a) The Contractor shall exert its best efforts to keep maintenance manuals, operator manuals and parts books up to date for a period of **eighteen (18) years**. The supplied manuals shall incorporate all equipment ordered on the buses covered by this procurement. In instances where copyright restrictions or other considerations prevent the Contractor from

incorporating major components information into the bus parts and service manuals, separate manual sets as published by the subcomponent Supplier will be provided.

D19. PARTS AVAILABILITY GUARANTEE

D19.1 Referencing APTA Guideline SP 7.3 Parts Availability Guarantee:

- (a) The Contractor hereby guarantees to provide, within 30 Business Days, the spare parts, software and all equipment necessary to maintain and repair the buses supplied under this Contract for a period of at least **eighteen (18) years** after the date of acceptance. Parts shall be interchangeable with the original equipment and shall be manufactured in accordance with the quality assurance provisions of this Contract. Prices shall not exceed the Contractor's then-current published catalog prices.

WARRANTY

D20. WARRANTY

D20.1 Notwithstanding C11, the Contractor shall, at its sole cost and expense, maintain the work against any and all defects or deficiencies or otherwise which may arise during the one (1) year period following the date on which each bus is inspected in accordance with E3.44 and is certified by the Contract Administrator as meeting the requirements of the Contract Documents (the "Comprehensive Warranty"). Each bus shall have a separate Comprehensive Warranty for one (1) year following completion of the post-delivery inspection.

D20.2 Referencing APTA Guideline WR 1.1.2 Complete Bus:

- (a) The complete bus, (excluding City of Winnipeg installed items), propulsion system, components, all subsystems and body and chassis structure are warranted to be free from defects and related defects for one year or 80,000 kilometres, whichever comes first, beginning on the date of revenue service. The warranty is based on regular operation of the bus under the operating conditions prevailing in the City's locale.
- (b) **In the event of "coach down" for repairs, in excess of 14 Calendar days, the warranty date shall be adjusted to compensate for the Calendar Days the coach was not in revenue service. In the event of Coach Down for warranty repairs, in excess of 30 Calendar days, Liquidated Damages as referenced in Clause D13 shall be incurred.**

D20.3 Referencing APTA Guideline WR1.1.3 Body and Chassis Structure:

- (a) All flooring, including ramp surfaces, shall be fully warranted for three (3) years or 240,000 kilometres, whichever comes first.
- (b) A structural defect or deficiency is defined as the permanent deformation, cracking, failure or corrosion of a structural member, its joints, welds or fasteners. A structural member shall include, but not be limited to, the upper welded structure, frame, chassis, floor, body panels, engine cradle and suspension mounting brackets and support structures.
- (c) **Primary load-carrying members of the bus structure, including structural elements of the suspension, are warranted against corrosion failure and/or Fatigue Failure sufficient to cause a Class 1 or Class 2 Failure for a period of 18 years or 1,200,000 kilometres, whichever comes first. Warranty coverage shall be comprehensive including all road and environmental conditions.**

D20.4 Referencing APTA Guideline WR1.1.4 Propulsion System:

- (a) Propulsion system components, specifically the engine, transmission, and drive and non-drive axles shall be warranted to be free from Defects and Related Defects for the standard two (2) years or 160,000 kilometres, whichever comes first.

D20.5 Referencing APTA Guideline WR1.1.5 Emission Control System (ECS):

- (a) The Contractor warrants the emission control system for five (5) years or 400,000 kilometres, whichever comes first. The ECS shall include, but is not limited to, the following components:
 - (i) complete exhaust system, including catalytic converter (if required);
 - (ii) after-treatment device; and
 - (iii) components identified as emission control devices

D20.6 Referencing APTA Guideline WR1.1.6 Subsystems:

- (a) Other subsystems shall be warranted to be free from Defects and Related Defects for two (2) years or 160,000 kilometres, whichever comes first. Other subsystems are listed below:
 - (i) Brake system: Foundation brake components, including advancing mechanisms, as supplied with the axles, excluding friction surfaces;
 - (ii) Destination signs: All destination sign equipment for the front, side and rear signs, power modules and operator control;
 - (iii) Heating, ventilating: Roof and/or rear main unit only, excluding floor heaters and front defroster;
 - (iv) AC unit and compressor: Roof and/or rear main unit only, excluding floor heaters and front defroster;
 - (v) Door systems: Door operating actuators and linkages;
 - (vi) Air compressor;
 - (vii) Air dryer;
 - (viii) Wheelchair lift and ramp system: Lift and/or ramp parts and mechanical only;
 - (ix) Starter;
 - (x) Alternator: Alternator only. Does not include the drive system;
 - (xi) Charge air cooler: Charge air cooler including core, tanks and including related surrounding framework and fittings;
 - (xii) Fire suppression: Fire suppression system including tank and extinguishing agent dispensing system;
 - (xiii) Hydraulic systems: Including radiator fan drive and power steering as applicable;
 - (xiv) Engine cooling systems: Radiator including core, tanks and related framework, including surge tank;
 - (xv) Transmission cooler;
 - (xvi) Passenger seating excluding upholstery;
 - (xvii) Fuel storage and delivery system;
 - (xviii) Surveillance system including cameras and video recorders; and
 - (xix) **All window assemblies including frames, rubber seals, and glass shall be warranted covering the integrity and deterioration or delamination of the glazing or a period of two years, in normal city service. Warranties shall cover all material, labor and workmanship, excluding damage caused by vandalism, bus accidents, poor care and maintenance.**

D20.7 Referencing APTA Guideline WR 1.1.8 Serial Numbers:

- (a) Upon delivery of each bus, the Contractor shall provide a complete electronic list of serialized units installed on each bus to facilitate warranty tracking. The list shall include, but is not limited to:
 - (i) Engine;
 - (ii) Transmission;
 - (iii) Alternator;
 - (iv) Starter;
 - (v) A/C compressor and condenser/evaporator unit;

- (vi) drive axle;
- (vii) power steering unit;
- (viii) fuel cylinders (if applicable);
- (ix) Aux heater;
- (x) wheelchair ramp (if applicable);
- (xi) HVAC Unit;
- (xii) driver's seat; and
- (xiii) DPF Filter Section.

- (b) The Contractor shall provide updated serial numbers resulting from warranty campaigns. The format of the list shall be approved by the City prior to delivery of the first production bus.

D20.8 Referencing APTA Guideline WR 1.1.9 Extension of Warranty:

- (a) If, during the warranty period, repairs or modifications on any bus are made necessary by defective design, materials or workmanship but are not completed due to lack of material or inability to provide the proper repair for thirty (30) Calendar days, the applicable warranty period shall be extended by the number of Calendar Days equal to the delay period.

D20.9 Referencing APTA Guideline WR 1.3.1 Pass-Through Warranty:

- (a) **The Contractor shall not transfer and be solely responsible for the administration of the warranty as specified with exception of the following: Engine, Transmission, Thermo-King, Destination Signs and batteries.**

D20.10 Referencing APTA Guideline WR 1.3.2 Superior Warranty:

- (a) The Contractor shall pass on to the City any warranty offered by a component Supplier that is superior to that required herein. The Contractor shall provide a list to the City noting the conditions and limitations of the Superior Warranty not later than the start of production. The Superior Warranty shall be administered by the Contractor.

REFERENCING APTA GUIDELINE WR 1.4 FLEET DEFECTS

D20.11 Referencing APTA Guideline WR 1.4.1 Occurrence and Remedy:

- (a) A Fleet Defect is defined as cumulative failures of twenty-five (25) percent of the same components in the same or similar application in a minimum fleet size of twelve (12) or more buses where such items are covered by warranty. A Fleet Defect shall apply only to the base warranty period in sections entitled "Complete Bus," "Propulsion System" and "Major Subsystems." When a Fleet Defect is declared, the remaining warranty on that item/component stops. The warranty period does not restart until the Fleet Defect is corrected.
- (b) For the purpose of Fleet Defects, each option order shall be treated as a separate bus fleet. In addition, should there be a change in a major component within either the base order or an option order; the buses containing the new major component shall become a separate bus fleet for the purposes of Fleet Defects.
- (c) The Contractor shall correct a Fleet Defect under the warranty provisions defined in "Repair Procedures." After correcting the Defect, the City and the Contractor shall mutually agree to and the Contractor shall promptly undertake and complete a work program reasonably designed to prevent the occurrence of the same Defect in all other buses and spare parts purchased under this Contract. Where the specific Defect can be solely attributed to particular identifiable part(s), the work program shall include redesign and/or replacement of only the defectively designed and/or manufactured part(s). In all other cases, the work program shall include inspection and/or correction of all of the buses in the fleet via a mutually agreed-to arrangement. The Contractor shall update, as necessary, technical support information (parts, service and operator's manuals) due to changes resulting from warranty repairs. The City may immediately declare a Defect in design

resulting in a safety hazard to be a Fleet Defect. The Contractor shall be responsible to furnish, install and replace all defective units.

REFERENCING APTA GUIDELINE WR 2 REPAIR PROCEDURES

D20.12 Referencing APTA Guideline WR 2.1 Repair Performance:

- (a) The Contractor is responsible for all warranty-covered repair Work. To the extent practicable, the City will allow the Contractor or its designated representative to perform such Work. At its discretion, the City may perform such Work if it determines it needs to do so based on transit service or other requirements. Such Work shall be reimbursed by the Contractor.
- (b) On notice by the City that the defect within the Warranty Period as defined in this section has occurred, the Contractor shall commence the Failure Analysis and Evaluation within five (5) Business Days. A final resolution of the claim, including failure analysis, testing, redesign, establishment of hours for repair, materials, etc. shall be completed within a period of 120 Calendar Days.

D20.13 Referencing APTA Guideline WR 2.2 Repairs by the Contractor:

- (a) **The Contractor, or its designated representative as agreed to by the City, shall, if requested, begin Work on warranty-covered repairs after receiving notification of a Defect from the City. The City shall make the bus available to complete repairs timely with the Contractor's repair schedule.**
- (b) The Contractor shall provide at its own expense all spare parts, tools and space required to complete repairs. At the City's option, the Contractor may be required to remove the bus from the City's property while repairs are being affected. If the bus is removed from the City's property, repair procedures must be diligently pursued by the Contractor's representative.

D20.14 Referencing APTA Guideline WR 2.3 Repairs by the City:

- (a) The City will not take responsibility to correct Defects, except to replace defective parts as instructed by the Contractor.

D20.15 Referencing APTA Guideline WR 2.3.1 Parts Used:

- (a) If the City performs the warranty-covered repairs, it shall correct or repair the Defect and any Related Defects utilizing parts supplied by the Contractor specifically for this repair. At its discretion, the City may use Contractor-specified parts available from its own stock if deemed in its best interests.

D20.16 Referencing APTA Guideline WR 2.3.2 Contractor-Supplied Parts:

- (a) The City may require that the Contractor supply parts for warranty-covered repairs being performed by the City. Those parts may be remanufactured but shall have the same form, fit and function, and warranty. The parts shall be shipped prepaid to the City from any source selected by the Contractor within fourteen (14) Calendar Days of receipt of the request for said parts and shall not be subject to a City handling charge.

D20.17 Referencing APTA Guideline WR 2.3.4 Failure Analysis:

- (a) The Contractor shall, upon specific request of the City, provide a failure analysis of Fleet Defect or safety-related parts, or major components, removed from buses under the terms of the warranty that could affect fleet operation. Such reports shall be delivered within 60 Calendar Days of the receipt of failed parts.

D20.18 Referencing APTA Guideline WR 2.3.5 Reimbursement for Labor and Other Related Costs:

- (a) **The City shall be reimbursed by the Contractor for all related labor including diagnostic time, repair and modifications. The amount shall be determined by the City for a qualified mechanic at a straight time wage rate of \$115.00 per hour, which includes fringe benefits and overhead adjusted for the City's most recently**

published rate in effect at the time the Work is performed, plus the cost of towing the bus if such action was necessary and if the bus was in the normal service area. These wage and fringe benefit rates shall not exceed the rates in effect in the City's service garage at the time the Defect correction is made.

- (b) **Annual wage rate changes to be calculated according to Producer Price Index referenced in Clause D2.2.**

D20.19 Referencing APTA Guideline WR 2.3.6 Reimbursement for Parts:

- (a) The City shall be reimbursed by the Contractor for defective parts and for parts that must be replaced to correct the Defect. The reimbursement shall be at the current price at the time of repair and shall include taxes where applicable, plus fifteen (15) percent handling costs. Handling costs shall not be paid if part is supplied by Contractor and shipped to City.

D20.20 Referencing APTA Guideline WR 2.3.7 Reimbursement Requirements:

- (a) The Contractor shall respond to a notification of a warranty defect with an accept/reject decision including necessary failure analysis no later than sixty (60) Calendar Days after the City submits the claim and defective part(s), when requested. Reimbursement for all accepted claims shall occur no later than sixty (60) Calendar Days from the date of acceptance of a valid claim. The City may dispute rejected claims or claims for which the Contractor did not reimburse the full amount. The parties agree to review disputed warranty claims during the following sixty (60) Calendar Days to reach an equitable decision to permit the disputed claim to be resolved and closed. The parties also agree to review all claims at least once per quarter throughout the entire warranty period to ensure that open claims are being tracked and properly dispositioned.

D20.21 Referencing APTA Guideline WR 2.4 Warranty after Replacement/Repairs:

- (a) **If any component, unit or subsystem is repaired, rebuilt or replaced by the Contractor or by the City with the concurrence of the Contractor, the component, unit or subsystem shall retain the balance of the original warranty period from the time of warranty notification. Repairs shall not be warranted if the Contractor-provided or authorized parts are not used for the repair, unless the Contractor has failed to respond within five Business Days, in accordance with "Repairs by the Contractor".**
- (b) If an item is declared to be a Fleet Defect, the warranty stops with the declaration of the Fleet Defect. Once the Fleet Defect is corrected, the item(s) shall have three (3) months or remaining time and/or kilometres of the original warranty, whichever is greater. This remaining warranty period shall begin on the repair/replacement date for corrected items on each bus if the repairs are completed by the Contractor or on the date the Contractor provides all parts to the City.

D20.22 Further to C11, the City and the Contractor may negotiate an agreement for the City's own forces to perform warranty repair work under the following conditions:

- (a) Monthly warranty repairs beyond 100 hours shall be charged at overtime rates;
- (b) Warranty repairs requiring over two hours will be performed on overtime after normal working hours or during weekends at overtime rates;
- (c) Warranty repairs requiring less than two hours may be performed on overtime to complete the repairs as quickly as possible if deemed necessary by the Contract Administrator;
- (d) The Contractor will either supply all materials necessary to perform the warranty repair or reimburse to the City, the full costs of parts and materials supplied by the City within 30 Calendar Days of use; and
- (e) Labour rates for warranty repair work performed by City forces during normal working hours will be \$115.00 per person hour, the overtime labour rate will be \$ 145.00 per person hour.

D20.23 Referencing APTA Guideline SP 1.5 Repairs after Non-Acceptance:

- (a) **The Contractor, or its designated representative, shall perform the repairs after non-acceptance within five (5) Business Days.**

D20.24 Referencing APTA Guideline SP 1.6.1 Repairs by Contractor:

- (a) After non-acceptance of the bus, the Contractor must begin Work within five (5) Business Days after receiving notification from the City of failure of acceptance tests.

D20.25 The Contractor shall provide, at its own expense, all spare parts, tools and space required to complete the repairs. At the City's option, the Contractor may be required to remove the bus from the City's property while repairs are being made. If the bus is removed from the City's property, repair procedures must be diligently pursued by the Contractor's representatives, and the Contractor shall assume risk of loss while the bus is under its control.

D20.26 Referencing APTA Guideline SP 1.6.2 Repairs by the City:

- (a) The City will not take responsibility to correct Defects, except to replace defective parts as instructed by the Contractor.
 - (i) Parts used. If the City performs the repairs after non-acceptance of the bus, it shall correct or repair the Defect and any Related Defects using Contractor-specified parts available from its own stock or those supplied by the Contractor specifically for this repair. Reports of all repairs covered by this procedure shall be submitted by the City to the Contractor for reimbursement or replacement of parts monthly, or at a period to be mutually agreed upon. The Contractor shall provide forms for these reports.
 - (ii) Contractor-supplied parts. If the Contractor supplies parts for repairs being performed by the City after non-acceptance of the bus, these parts shall be shipped prepaid to the City.
 - (iii) Return of defective components. The Contractor may request that parts covered by this provision be returned to the manufacturing plant. The total costs for this action shall be paid by the Contractor.
 - (iv) Reimbursement for labor. The City shall be reimbursed by the Contractor for labor. The amount shall be determined by the City for a qualified mechanic at a straight time wage rate of **\$115.00** per hour and overtime wage rate of **\$145.00** per hour, which includes fringe benefits and overhead adjusted for the City's most recently published rate in effect at the time the Work is performed, plus the cost of towing in the bus, if such action was necessary.
 - (v) Reimbursement for parts. The City shall be reimbursed by the Contractor for defective parts that must be replaced to correct the Defect. The reimbursement shall include taxes where applicable and fifteen (15) percent administrative costs.

PART E - SPECIFICATIONS

GENERAL

E1. APPLICABLE SPECIFICATIONS AND DRAWINGS

- E1.1 These Specifications shall apply to the Work.
- E1.2 These Specifications are intended to leave the Bidder free to provide his own design for the basic vehicle and equipment, subject to compliance with items specifically identified. The responsibility for providing vehicles with structures and components suitable for urban transit operations that meet all applicable municipal, provincial and federal regulations rests with the Bidder.
- E1.3 This technical specification E2 is based on the American Public Transportation Association (APTA) Bus Procurement Guide version 2013. Deviations from the white book are identified by text in **bold**.
- E1.4 The following is applicable to the Work:
Drawing No. DLF40
Drawing of Bus Paint Scheme
- E1.5 Bidders are reminded that requests for approval of substitutes as an approved equal or an approved alternative shall be made in accordance with B6.. In every instance where a brand name or design specification is used, the City will also consider approved equals and/or approved alternatives in accordance with B6.

E2. GOODS

- E2.1 The Contractor shall supply forty foot (40') heavy-duty low-floor diesel transit bus in accordance with the requirements hereinafter specified. Dimensions and characteristics are given to indicate the size and type of buses required. The dimensions are approximate, except where identified as maximums or minimums, and may be varied with the approval of the City.
- E2.2 The City intends to operate these buses for a minimum of eighteen (18) years and buses purchased under this Contract must meet this service life requirement.
- E2.3 Buses must be of the accessible "Low Floor" design without steps at the front and rear doors. "Forty Foot" buses require a minimum seating capacity of 38 passengers and a minimum total capacity of 80 passengers. Buses must be equipped with the necessary convertible ambulatory seating to create two wheelchair positions at the front of the bus when required.
- E2.4 The Bidder's bus design must have completed STURAA at the 12-year, 500,000 mile service life level, structural durability, strength and distortion testing at the Urban Mass Transit Administration's testing facility in Altoona, Pennsylvania.
- E2.5 Referencing APTA Guideline TS 1. Scope:
- (a) Technical specifications define requirements for heavy-duty transit buses, which, by the selection of specifically identified alternative configurations, may be used for both suburban express service and general service on urban arterial streets. Buses shall have a minimum expected life of eighteen (18) years or 1,200,000 kilometres, whichever comes first, and are intended for the widest possible spectrum of passengers, including children, adults, the elderly and people with disabilities. A current detailed technical summary, including a working index, shall be provided and maintained.

E2.6 Referencing APTA Guideline TS 2. Definitions:

- (a) **Ambient Temperature:** The temperature of the surrounding air.
- (b) **Analog Signals:** A continuously variable signal that is solely dependent upon magnitude to express information content.
 - (i) NOTE: Analog signals are used to represent the state of variable devices such as rheostats, potentiometers, temperature probes, etc.
- (c) **Audible Discrete Frequency:** An audible discrete frequency is determined to exist if the sound power level in any 1/3-octave band exceeds the average of the sound power levels of the two adjacent 1/3-octave bands by 4 decibels (dB) or more.
- (d) **Battery Compartment:** 12/24 VDC batteries storage.
- (e) **Battery Management System (BMS):** Monitors energy (amperage), as well as temperature, cell or module voltages, and total pack voltage. The BMS adjusts the control strategy algorithms to maintain the batteries at uniform state of charge and optimal temperatures.
- (f) **Capacity (fuel container):** The water volume of a container in gallons (liters).
- (g) **Code:** A legal requirement.
- (h) **Continuous Cables:** Cables that are not interrupted by any type of splice.
- (i) **Curb Weight:** Weight of vehicle, including maximum fuel, oil and coolant; and all equipment required for operation and required by this Specification, but without passengers or operator.
- (j) **dBa:** Decibels with reference to 0.0002 microbar as measured on the "A" scale.
- (k) **DC to DC Converter:** A module which converts a source of direct current (DC) from one voltage level to another.
- (l) **Destroyed:** Physically made permanently unusable.
- (m) **Discrete Signal:** A signal that can take only pre-defined values, usually of a binary 0 or 1 nature where 0 is battery ground potential and 1 is a defined battery positive potential.
- (n) **DPF:** Diesel particulate filter.
- (o) **Operator's Eye Range:** The 95th-percentile ellipse defined in SAE Recommended Practice J941, except that the height of the ellipse shall be determined from the seat at its reference height.
- (p) **Fire Resistant:** Materials that have a flame spread index less than 150 as measured in a radiant panel flame test per ASTM-E 162-90.
- (q) **Fireproof:** Materials that will not burn or melt at temperatures less than 2000 °F (1093 °C).
- (r) **Free Floor Space:** Floor area available to standees, excluding the area under seats, area occupied by feet of seated passengers, the vestibule area forward of the standee line, and any floor space indicated by manufacturer as non-standee areas such as, the floor space "swept" by passenger doors during operation. Floor area of 1.5 sq. ft. shall be allocated for the feet of each seated passenger that protrudes into the standee area.
- (s) **GAWR (Gross Axle Weight Rated):** The maximum total weight as determined by the axle manufacturer, at which the axle can be safely and reliably operated for its intended purpose.
- (t) **Gross Load:** 150 lbs for every designed passenger seating position, for the operator, and for each 1.5 square feet of free floor space.
- (u) **GVW (Gross Vehicle Weight):** Curb weight plus gross load.
- (v) **GVWR (Gross Vehicle Weight Rated):** The maximum total weight as determined by the vehicle manufacturer, at which the vehicle can be safely and reliably operated for its intended purpose.
- (w) **Hose:** Flexible line.

- (x) **Labeled:** Equipment or materials to which has been attached a label, symbol or other identifying mark of an organization, which is acceptable to the authority having jurisdiction and concerned with product evaluation, which maintains periodic inspection of production labeled equipment or materials, and by whose labeling the manufacturer indicates compliance with appropriate standards or performance in a specified manner.
- (y) **Leakage:** Release of contents through a Defect or crack. See Rupture.
- (z) **Line:** All tubes, flexible and hard, that carry fluids.
- (aa) **Local Regulations:** Regulations below the provincial level.
- (bb) **Low-Floor Bus:** A bus that, between at least the front (entrance) and rear (exit) doors, has a floor sufficiently low and level so as to remove the need for steps in the aisle between the doors and in the vicinity of these doors.
- (cc) **Low Voltage (LV):** 50 volts or less (AC and DC).
- (dd) **Metallic Hose:** A hose whose strength depends primarily on the strength of its metallic parts; it can have metallic liners or covers, or both.
- (ee) **Module:** Assembly of individual components.
- (ff) **Operating Pressure:** The varying pressure developed in a container during service.
- (gg) **Physical Layer:** The first layer of the seven-layer International Standards Organization (ISO) Open Systems Interconnect (OSI) reference model. This provides the mechanical, electrical, functional and procedural characteristics required to gain access to the transmission medium (e.g., cable) and is responsible for transporting binary information between computerized systems.
- (hh) **Pipe:** Nonflexible line.
- (ii) **Power:** Work or energy divided by time.
- (jj) **Power Density:** Power divided by mass, volume or area.
- (kk) **Propulsion System:** System that provides propulsion for the vehicle proportional to operator commands.
- (ll) **Real-Time Clock (RTC):** Computer clock that keeps track of the current time.
- (mm) **Retarder:** Device used to augment or replace some of the functions of primary friction based braking systems of the bus.
- (nn) **Seated Load:** 150 lbs for every designed passenger seating position and for the operator.
- (oo) **SLW (Seated Load Weight):** Curb weight plus seated load.
- (pp) **Serial Data Signals:** A current loop based representation of ASCII or alphanumeric data used for transferring information between devices by transmitting a sequence of individual bits in a prearranged order of significance.
 - (i) NOTE: An example is the communication that takes place between two or more electronic components with the ability to process and store information.
- (qq) **Special Tools:** Tools not normally stocked by the City.
- (rr) **Specification:** A particular or detailed statement, account, or listing of the various elements, materials, dimensions, etc. involved in the manufacturing and construction of a product.
- (ss) **Standard:** A firm guideline from a consensus group.
- (tt) **Standards:** Standards referenced in "Part 6: Technical Specifications" are the latest revisions unless otherwise stated.
- (uu) **Standee Line:** A line marked across the bus aisle to designate the forward area that passengers may not occupy when the bus is moving.
- (vv) **State of Charge (SOC):** Quantity of electric energy remaining in the battery relative to the maximum rated Amp hour (Ah) capacity of the battery expressed in percent. This is a dynamic measurement used for the energy storage system.

- (ww) **Stress Loops:** The “pig-tails” commonly used to absorb flexing in piping.
- (xx) **Structure:** The structure shall be defined as the basic body, including floor deck material and installation, load bearing external panels, structural components, axle mounting provisions and suspension beams and attachment points.
- (yy) **Wheelchair:** A mobility aid belonging to any class of three- or four-wheeled devices, usable indoors, designed for and used by individuals with mobility impairments, whether operated manually or powered. A “common wheelchair” is such a device that does not exceed 30 inches in width and 48 inches in length measured 2 inches above the ground, and does not weigh more than 600 lbs when occupied.

E2.7 Referencing APTA Guideline TS 3. Referenced Publications:

- (a) The documents or portions thereof referenced within this specification shall be considered part of the requirements of the specification. The edition indicated for each referenced document is the current edition, as of the date of the APTA issuance of this specification.

E2.8 Referencing APTA Guideline TS 4. Legal Requirements:

- (a) The Contractor shall comply with all applicable federal, provincial and local regulations. These shall include but not be limited to the City of Winnipeg Universal Design Guidelines, as well as provincial and local safety and security requirements. Local regulations are defined as those below the provincial level.
- (b) In the event of any conflict between the requirements of these specifications and any applicable legal requirement, the legal requirement shall prevail. Technical requirements that exceed the legal requirements are not considered to conflict.

E2.9 Proprietary Components:

- (a) Use of components designed to be proprietary components will not be allowed.

E2.10 Referencing APTA Guideline TS 5.1 Weight:

- (a) It shall be a design goal to construct each bus as light in weight as possible without degradation of safety, appearance, comfort, traction or performance.
- (b) Buses at a capacity load shall not exceed the tire factor limits, brake test criteria or structural design criteria.

E2.11 Referencing APTA Guideline TS 5.2 Capacity:

- (a) The vehicle shall be designed to carry the gross vehicle weight, which shall not exceed the bus GVWR.

E2.12 Referencing APTA Guideline TS 5.3 Service Life:

- (a) The minimum service life of the bus in transit service shall be at least eighteen (18) years or one million (1,000,000) kms. It shall be capable of operating at least sixty-five thousand (65,000) kms per year, including the 18th year.

E2.13 Referencing APTA Guideline TS 5.4 Maintenance and Inspection:

- (a) All scheduled maintenance tasks shall be defined and shall be in accordance with the manufacturer’s recommended preventative maintenance schedule (along with routine daily service performed during the fueling operations).
- (b) Test ports, as required and in agreement with the City, shall be provided for commonly checked functions on the bus, such as air intake, exhaust, hydraulic, pneumatic, charge-air and engine cooling systems. **(Engine cooling system is a Parker Hannifin BH1-61.)**
- (c) The coach manufacturer shall give prime consideration to the routine problems of maintaining the vehicle. All coach components and systems, both mechanical and electrical, which will require periodic physical work or inspection processes, shall be installed so that a minimum of time is consumed in gaining access to the critical repair areas. It shall not be necessary to disassemble portions of the coach structure and/or equipment such as seats and flooring under seats in order to gain access to these areas.

- (d) Each coach shall be designed to facilitate the disassembly, reassembly, servicing or maintenance, using tools and equipment that are normally available as standard commercial items.
- (e) Requirements for the use of unique specialized tools will be minimized. The body and structure of the coach shall be designed for ease of maintenance and repair. Individual panels or other equipment which may be damaged in normal service shall be repairable or replaceable.
- (f) Contractor shall provide a list of all special tools and pricing required for maintaining this equipment. Said list shall be submitted as a supplement to the Pricing Schedule.
 - (i) NOTE: Tools such as compartment door keys, bellows gauges? and other tools that are required for daily maintenance and inspections shall not be included in the special tool list and shall be furnished for each coach.

E2.14 Referencing APTA Guideline TS 5.5 Interchangeability:

- (a) Unless otherwise pre-approved by the City, all units and components procured under this Contract, whether provided by Suppliers or manufactured by the Contractor, shall be duplicates in design, manufacture and installation to ensure interchangeability among buses in each order group in this procurement. This interchangeability shall extend to the individual components as well as to their locations in the buses. These components shall include, but are not limited to, passenger window hardware, interior trim, lamps, lamp lenses and seat assemblies. Components with non-identical functions shall not be, or appear to be, interchangeable.
- (b) Any one component or unit used in the construction of these buses shall be an exact duplicate in design, manufacture and assembly for each bus in each order group in this Contract. Contractor shall identify and secure approval for any changes in components or unit construction provided within a Contract.
- (c) In the event that the Contractor is unable to comply with the interchangeability requirement, the Contractor must notify the City and obtain the City's prior written approval, including any changing in pricing.
- (d) The City shall review proposed product changes on a case-by-case basis and shall have the right to require extended warranties to ensure that product changes perform as least as well as the originally supplied products.

E2.15 Referencing APTA Guideline TS 5.6 Training:

- (a) The Contractor shall provide at least one qualified instructor who shall be available at the City's property between the hours of 07:00 to 14:00 (or as agreed to by the City) within 6 months of agencies request. Instructor(s) shall conduct schools and advise the personnel of the City on the proper operation, diagnosis and maintenance of the equipment. The Contractor also shall provide visual and other teaching aids (such as manuals, slide presentations and literature) for use by the City's own training staff and which becomes the property of the City.
- (b) **100 instructor hours shall be provided for the initial Bid Opportunity and each of the 4 extensions. Instruction hours shall accumulate until used or otherwise expensed by the City.**

E2.16 Referencing APTA Guideline TS 5.6.1 Technical/Service Representatives

- (a) The Contractor shall, at its own expense, have one or more competent technical service representatives available on request to assist the City in the solution of engineering or design problems within the scope of the specifications that may arise during the warranty period. This does not relieve the Contractor of responsibilities under the provisions of D20.

- E2.17 Referencing APTA Guideline TS 5.7 Operating Environment:
- (a) The bus shall achieve normal operation in ambient temperature ranges of -40°C to 46°C, at relative humidity between 5 percent and 100 percent. Degradation of performance due to atmospheric conditions shall be minimized at temperatures below -40 °C, above 46 °C. Speed, gradability and acceleration performance requirements shall be met at, or corrected to, 25 °C, 29.31 in. Hg, dry air per SAE J1995.
- E2.18 Referencing APTA Guideline TS 5.8.1 Interior Noise:
- (a) The combination of inner and outer panels and any material used between them shall provide sufficient sound insulation so that a sound source with a level of 80 dBA measured at the outside skin of the bus shall have a sound level of 65 dBA or less at any point inside the bus. These conditions shall prevail with all openings, including doors and windows, closed and with the engine and accessories switched off.
 - (b) The bus-generated noise level experienced by a passenger at any seat location in the bus shall not exceed 80 dBA. The operator area shall not experience a noise level of more than 75 dBA.
- E2.19 Referencing APTA guideline ST 5.8.2 Exterior Noise:
- (a) Airborne noise generated by the bus and measured from either side shall not exceed 80 dBA under full power acceleration when operated 0 to 55 km/h at curb weight. The maximum noise level generated by the bus pulling away from a stop at full power shall not exceed 83 dBA. The bus-generated noise at curb idle shall not exceed 65 dBA. If the noise contains an audible discrete frequency, a penalty of 5 dBA shall be added to the sound level measured. The Contractor shall comply with the exterior noise requirements defined in local laws and ordinances identified by the City and SAE J366.
- E2.20 Referencing APTA Guideline TS 5.10 Fire Safety:
- (a) An Amerex fire suppression system is required.**
 - (b) All materials used in the construction of the passenger compartment of the bus shall be in accordance with the Recommended Fire Safety Practices defined in FMVSS 302, dated October 20, 1993. Materials entirely enclosed from the passenger compartment, such as insulation within the sidewalls and sub-floor, need not comply. In addition, smaller components and items, such as seat grab rails, switch knobs and small light lenses, shall be exempt from this requirement.
- E2.21 Referencing APTA Guideline TS 5.11 Respect for the Environment:
- (a) In the design and manufacture of the bus, the Contractor shall make every effort to reduce the amount of potentially hazardous waste. In accordance with Section 6002 of the Resource Conservation and Recovery Act, the Contractor shall use, whenever possible and allowed by the specifications, recycled materials in the manufacture of the bus.
- E2.22 Referencing APTA Guideline TS 6. Physical Size:
- (a) Nominal 40' x 102" wide heavy-duty low-floor transit bus.**
- E2.23 Referencing APTA Guideline TS 6.1 Bus Length:
- (a) For ease of use, the following tolerances will be allowable for each given bus length. Bus length is determined as the measurement from bumper to bumper.
 - (i) 40-ft bus: 40 ft. to 41 ft.**
 - (ii) 60 ft. (Optional) bus: 60 ft. to 61 ft.**
- E2.24 Referencing APTA Guideline TS 6.2 Bus Width:
- (a) 102 in. Width Bus .
 - (b) Body width shall be 102 inches (+0, -1 in.).

E2.25 Referencing APTA Guideline TS 6.3 Bus Height: Maximum Overall Height:

- (a) Maximum overall height shall be 126 inches, including all rigid, roof-mounted items such as A/C, exhaust, fuel system and cover, etc.

E2.26 Referencing APTA Guideline TS 6.4 Step Height:

- (a) **The step height shall not exceed 14.6 inches at either doorway without kneeling. A maximum of two steps is allowed to accommodate a raised aisle floor in the rear of the bus.**

E2.27 Referencing APTA Guideline TS 6.5 Under Body Clearance:

- (a) The bus shall maintain the minimum clearance dimensions as shown in Figure 2 and defined in SAE Standard J689, regardless of load up to the gross vehicle weight rating.

E2.28 Referencing APTA Guideline TS 6.6 Ramp Clearances:

- (a) The approach angle is the angle measured between a line tangent to the front tire static loaded radius arc and the initial point of structural interference forward of the front tire to the ground.
- (b) The departure angle is the angle measured between a line tangent to the rear tire static loaded radius arc and the initial point of structural interference rearward of the rear tire to the ground.
- (c) The break over angle is the angle measured between two lines tangent to the front and rear tire static loaded radius and intersecting at a point on the underside of the vehicle that defines the largest ramp over which the vehicle can roll.
- (d) Breakover Angle:

Angle	30 to 45 ft. Bus
<i>Approach</i>	<i>8.6 degrees (min.)</i>
<i>Rear breakover</i>	<i>8 degrees (min.)</i>
<i>Departure</i>	<i>8.7 degrees (min)</i>

E2.29 Referencing APTA Guideline TS 6.7 Ground Clearance:

- (a) Ground clearance shall be no less than 9 inch, (8 in. at jacking pad) except within the axle zone and wheel area.
- (b) Axle zone clearance, which is the projected area between tires and wheels on the same axial centerline, shall be no less than 5.4 inches.
- (c) Wheel area clearance shall be no less than 8 inch for parts fixed to the bus body and 6 inch for parts that move vertically with the axles.

(d) Figure 2.

FIGURE 2

Transit Bus Minimum Road Clearance

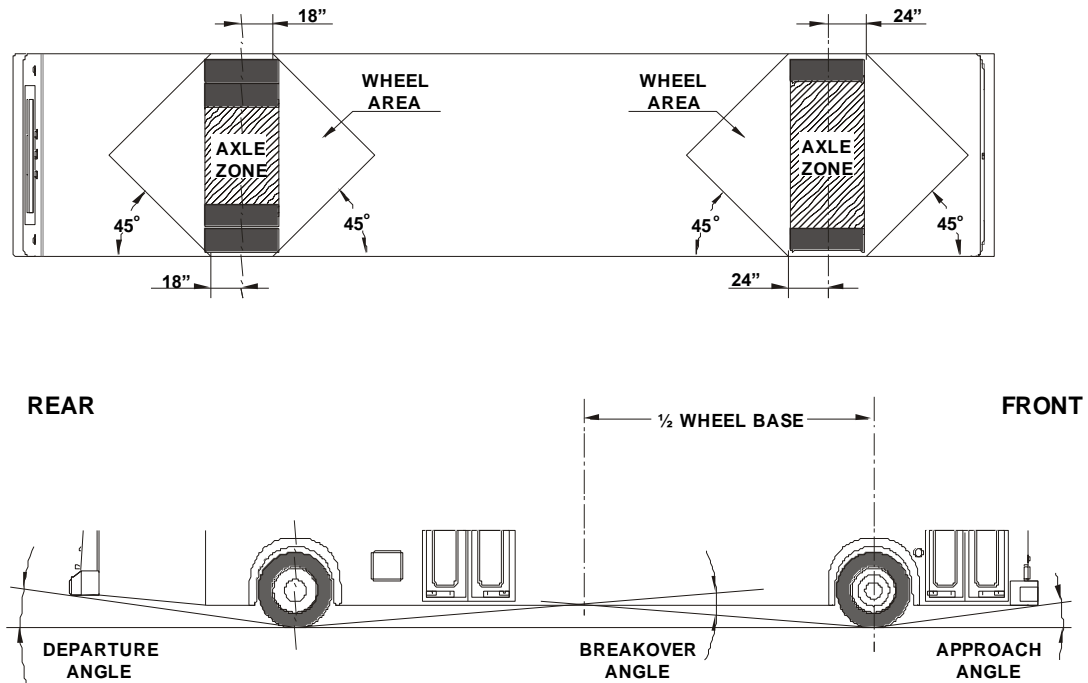

E2.30 Referencing APTA Guideline TS 6.8 Floor Height:

- (a) Height of the step above the street shall be no more than 14.6 in measured at the centerline of the front and rear doorway. The floor may be inclined along the longitudinal axis of the bus, and the incline shall not exceed 3.5 degrees off the horizontal except locally at the doors where 2 degree slope toward the door is allowed. All floor measurements shall be with the bus at the design running height and on a level surface and with the standard installed tires. A maximum of two steps is allowed to accommodate a raised aisle floor in the rear of the bus.

E2.31 Referencing APTA Guideline TS 6.9 Interior Headroom:

- (a) Headroom above the aisle and at the centerline of the aisle seats shall be no less than 78 inches in the forward half of the bus tapering to no less than 74 inches forward of the rear settee. At Headroom above the aisle and at the centerline of the aisle seats shall be no less than 78 inches in the forward half of the bus tapering to no less than 74 inches forward of the rear settee. At the centerline of the window seats, headroom shall be no lower than 65 inches, except for parcel racks and reading lights, if specified. Headroom at the back of the rear bench seat may be reduced to a minimum of 56 inches, but it shall increase to the ceiling height at the front of the seat cushion. In any area of the bus directly over the head of a seated passenger and positioned where a passenger entering or leaving the seat is prone to strike his or her head, padding shall be provided on the overhead paneling. The centerline of the window seats, headroom shall be no lower than 65 inches, except for parcel racks and reading lights, if specified. Headroom at the back of the rear bench seat may be reduced to a minimum of 56 inches, but it shall increase to the ceiling height at the front of the seat cushion. In any area of the bus directly over the head of a seated passenger and positioned where a passenger entering or leaving the seat is prone to strike his or her head, padding shall be provided on the overhead paneling.

E2.32 Aisle Width:

- (a) **The minimum clear aisle width between pairs of transverse seats with all attached hardware shall be at least 22 inches.**
- (b) **The aisle width between the front wheelhouses shall be at least 35 inches, and the entire area between the front wheelhouses shall be available for passengers and mobility aid devices.**

E2.33 Referencing APTA Guideline TS 7. Power Requirements:

- (a) The propulsion system shall be sized to provide sufficient power to enable the bus to meet the defined acceleration, top speed, and gradability requirements, and operate all propulsion- driven accessories using actual road test results and computerized vehicle performance data.

E2.34 Referencing APTA Guideline TS 7.1 Top Speed:

- (a) The bus shall be capable of achieving a top speed governed at 90 km/h on a straight, level road at GVWR with all accessories operating. The bus shall be capable of safely maintaining the vehicle speed according to the recommendations by the tire manufacturer.
 - (i) NOTE: Values are assumed to be sustained. Manufacturer shall supply the City with data if there is a variance between peak performance and sustained vehicle performance

E2.35 Referencing APTA Guideline TS 7.2 Gradability:

- (a) Gradability requirements shall be met on grades with a dry commercial asphalt or concrete pavement at GVWR with all accessories operating.
- (b) The propulsion system and drivetrain shall enable the bus to achieve and maintain a speed of 65 km/h on a 2½ percent ascending grade and 25 km/h on a 10 percent ascending grade continuous.
 - (i) NOTE: Values are assumed to be sustained. Manufacturer shall supply the City with data if there is a variance between peak performance and sustained vehicle performance.

E2.36 Referencing APTA Guideline TS 7.3 Acceleration:

- (a) The acceleration shall meet the requirements below and shall be sufficiently gradual and smooth to prevent throwing standing passengers off-balance. Acceleration measurement shall commence when the accelerator is depressed.
- (b) Maximum Start Acceleration Times on a Level Surface.

<i>Speed (km/h)</i>	<i>Maximum Time (seconds)</i>
16	5
32	10
48	18
64	30
80	60
<i>Top Speed</i>	

Vehicle weight – GVWR

- E2.37 Referencing APTA Guideline TS 7.4 Operating Range:
- (a) The operating range of the coach shall be designed to meet the operating profile as stated in the “Design Operating Profile” section.
- E2.38 Referencing APTA Guideline TS 7.4.1 Diesel:
- (a) The operating range of the coach when run on the Altoona Test cycle shall be at least 560 km or 20 hours with full fuel capacity.**
- E2.39 Referencing APTA Guideline TS 8. Fuel Economy (Design Operating Profile):
- (a) Test results from the Altoona fuel economy tests or other applicable test procedures shall be provided to the City. Results shall include vehicle configuration and test environment information. Fuel economy data shall be provided for each design operating profile. The design operating profile is assumed to be defined by the Altoona fuel duty cycle.
- E2.40 Referencing APTA Guideline TS 9. Engine:
- (a) The engine shall be equipped with an electronically controlled management system, compatible with either 12 or 24 volt power distribution. The engine control system shall be capable of transmitting and receiving electronic inputs and data from other drivetrain components and broadcasting that data to other vehicle systems. Communication between electronic drivetrain components and other vehicle systems shall be made using the communications networks. The engine’s/Transmission electronic management system shall monitor operating conditions and provide instantaneous adjustments to optimize both engine and bus performance. The system shall be programmable to allow optimization of programmable features.
 - (b) The engine starting system shall be protected by an interlock that prevents its engagement when the engine is running. The engine control system shall protect the engine against progressive damage. The system shall monitor conditions critical for safe operation and automatically derate power and/or speed and initiate engine shutdown as needed.
 - (c) Automatic Engine Protection/Shutdown Override Feature.
 - (d) A control shall be available to the operator that when constantly depressed and released will delay the engine shutdown or allow the bus to be moved. Override action shall be recorded. This data shall be retrievable by the City.
- E2.41 Referencing APTA Guideline TS 9 Engine (Diesel):
- (a) The engine shall be a Cummins ISL 9 280hp with 900 lb/ft torque and shall comply with applicable local, state, and/or federal emissions and useful life requirements. Components of the fuel management and/or control system shall have a design life of not less than 240,000 kms without replacement or major service. The lifetime estimate is based on the design operating profile.**
 - (b) The engine and related emission systems shall meet all applicable emissions and design/durability guidelines and standards with ease of access to DEF tank and sensors for serviceability. Contractor shall provide the City with expected durability of the engine and related emission systems. The engine shall be equipped with an electronically controlled management system, compatible with multiplex wiring systems and either 12 or 24 volt electrical systems.**
 - (c) The engine shall have on-board diagnostic capabilities, able to monitor vital functions, store out-of-parameter conditions in memory, and communicate faults and vital conditions to service personnel. Diagnostic reader device connector ports, suitably protected against dirt and moisture, shall be provided in operator’s area and near or inside engine compartment. The on-board diagnostic system shall inform the operator via visual and/or audible alarms when out-of-parameter conditions exist for vital engine functions. **All ECM wiring within the engine compartment must be protected against dirt, moisture and high heat, wrapped with spiral wrap inside of loom.**
 - (d) The engine starting system shall be protected by an interlock that prevents its engagement when the engine is running. Special equipment or procedures may be employed to start

the engine when exposed to temperatures less than -1°C for a minimum of four hours without the engine in operation. All cold weather starting aids, engine heating devices and procedures shall be of the type recommended by the engine manufacturer and approved by the City.

- (e) Standard Requirements for a Fast Idle Device.
- (f) The engine shall be equipped with an operator-controlled fast idle device. The fast idle control shall be a two-way switch mounted on the dash or side console and shall activate only with the transmission in neutral and the parking brake applied.

E2.42 Referencing APTA Guideline TS 10. Cooling Systems:

- (a) The cooling systems shall be of sufficient size to maintain all engine and transmission fluids and engine intake air at safe, continuous operating temperatures during the most severe operations possible and in accordance with engine and transmission manufacturers' cooling system requirements. The cooling system fan controls should sense the temperatures of the operating fluids and the intake air, and if either is above safe operating conditions the cooling fan should be engaged. The fan control system shall be designed with a fail-safe mode of "fan on." The cooling system shall meet the requirements stated in the operating environment.
- (b) **Must have serviceable water strainer located after booster pump to prevent debris from damaging cooling system components such as water valves, heater cores, etc. Sporlan filter P/N 125YSB.**
- (c) **Coolant control valve to control flow to heaters must have stainless steel seats.**

E2.43 Referencing APTA Guideline TS 10.1 Engine Cooling:

- (a) A means of determining satisfactory engine coolant level shall be provided. A spring-loaded, or lever shall be provided to safely release pressure or vacuum in the cooling system with both it and the water filler no more than 60 inches above the ground. Both shall be accessible through the same access door.
- (b) The radiator shall be of durable, corrosion-resistant construction. **The radiator or cooling system must have pressure fill/drain quick connectors connected to the lowest parts of the cooling systems accessible from the rear of the engine door.**
- (c) Radiators with a fin density greater than 12 fins per inch or a louvered slit design shall not be used. No heat-producing components or climate control system components shall be mounted between the engine cooling air intake aperture and the radiator. The radiator and charge air cooler shall be designed to withstand thermal fatigue and vibration associated with the installed configuration. The radiator and charge air cooler cores shall be easily cleaned (to include engine side core surface) with standard pressure-washing equipment.
- (d) Radiator Screen in Front of Radiator and Charge Air Cooler.
 - (i) For radiators with lower edge less than 36 inches to the ground.
 - (ii) **The radiator and air cooler shall be protected by an aluminum perforated screen with staggered ¼" holes. The screen shall be capable of maintaining sufficient air flow for the cooling requirements.**
- (e) Standard Requirement for Coolant Filtration.
 - (i) The engine cooling system shall be equipped with a properly sized water filter/additive with a spin-on element and an automatic system for releasing supplemental coolant additives as needed to replenish and maintain protection properties. When replacing the water filter, only the water in the filter will be lost.
- (f) Cooling Fan Control and Drive Design.
 - (i) Control and drive of the radiator and charge air cooler fan(s) shall be an electric Modine system.
 - (ii) The cooler fans shall have integrated controllers. Cooler fans shall be capable of automated reverse operations for periodic self-cleaning of the radiator and charge air cooler. **Reversing can be terminated with momentary switch.** Radiator cooling and Charge Air cooling must operate independently.

- (g) Coolant Sensors.
 - (i) **Coolant sensor must be Veritech Inc. (VeriTranz Brand) PN: VT220596 or equivalent for both engine and cabin systems if equipped.**

E2.44 Referencing APTA Guideline TS 10.2 Charge Air Cooling:

- (a) The charge air cooling system also referred to as after-coolers or inter-coolers shall provide maximum air intake temperature reduction with minimal pressure loss. The charge air radiator shall be sized and positioned to meet engine manufacturer's requirements. The charge air radiator shall not be stacked ahead of or behind the engine radiator and shall be positioned as close to the engine as possible unless integrated with the radiator. Air ducting and fittings shall be protected against heat sources and shall be configured to minimize restrictions and maintain sealing integrity.
- (b) **The charge air cooler shall be of durable, corrosion-resistant construction.**

E2.45 Referencing APTA Guideline TS 10.3 Transmission Cooling:

- (a) The transmission shall be cooled by a dedicated heat exchanger sized to maintain operating fluid within the transmission manufacturer's recommended parameters of flow, pressure and temperature. The transmission cooling system shall be matched to retarder and engine cooling systems to ensure that all operating fluids remain within recommended temperature limits established by each component manufacturer. The engine cooling system should provide coolant bypass flow to the transmission cooling system with the engine thermostats closed.

E2.46 Referencing APTA Guideline TS 11. Transmission (Conventional Powertrain):

- (a) The transmission shall be an **Allison Transmission B3400R XFE** or City approved other, supplied with **TranSynd transmission fluid**.
- (b) Gross input power, gross input torque and rated input speed shall be compatible with the engine. The transmission shall be designed to operate for not less than 480,000 kms on the design operating profile without replacement or major service. The transmission should be easily removable without disturbing the engine and accessible for service.
- (c) The electronic controls shall be capable of transmitting and receiving electronic inputs and data from other drivetrain components and broadcasting that data to other vehicle systems. Communication between electronic drivetrain components and other vehicle systems shall be made using the communications networks. Electronic controls shall be compatible with 24 volt power distribution, provide consistent shift quality and compensate for changing conditions such as variations in vehicle weight and engine power. **All TCM wiring within the engine compartment must be protected against dirt, moisture and high heat, wrapped with spiral wrap inside of loom. The transmission wiring harness from the TCM to the transmission must be color coded to match Allison wiring schematics.**
- (d) A nominal brake pedal application of 6 to 10 psi shall be required by the operator to engage forward or reverse range from the neutral position to prevent sudden acceleration of the bus from a parked position.
- (e) The electronically controlled transmission shall have on-board diagnostic capabilities, be able to monitor functions, store and time stamp out-of-parameter conditions in memory, and communicate faults and vital conditions to service personnel. The transmission shall contain built-in protection software to guard against severe damage. The on-board diagnostic system shall trigger a visual alarm to the operator when the electronic control unit detects a malfunction. Alison Fuel sense 2.0 Max, or latest version, with Prognostics enabled or City approved other.
- (f) An electronic transmission fluid level monitoring and protection system shall be provided.

- (g) Automatic Neutral Function with Automatic Re-engagement.
 - (i) The transmission, when in forward direction, shall automatically shift the transmission to neutral when the vehicle registers zero road speed, engine is idle and service brakes are applied. If the status of any one or more of the three signals changes, the transmission immediately and automatically resumes forward mode operation.

E2.47 Referencing APTA Guideline TS 12. Retarder:

- (a) The powertrain shall be equipped with a minimum 2 stage retarder designed to maximize brake lining service life. The application of the retarder shall cause a smooth blending of both retarder and service brake function and shall not activate the brake lights. Actuation of ABS and/or automatic traction control (ATC) shall override the operation of the brake retarder.
- (b) The retarder shall be adjustable within the limits of the powertrain and activated when the brake pedal is depressed. The City will work with the contractor to determine retarder performance settings.
- (c) Accessible Retarder Disable Switch.
 - (i) The retarder disable switch shall be accessible to the seated operator, located above operator, approved by the City.
 - (ii) Disabling retarder shall be recorded for the City data collection.

E2.48 Referencing APTA Guideline TS 13. Mounting:

- (a) All power-plant mounting shall be mechanically isolated to minimize transfer of vibration to the body structure and provide a minimum clearance of 0.75 in. Mounts shall control the movement of the power-plant so as not to affect performance of belt-driven accessories or cause strain in piping and wiring connections to the power-plant.

E2.49 Referencing APTA Guideline TS 13.1 Service:

- (a) The propulsion system shall be arranged for ease of access and maintenance. The Contractor shall list all special tools, fixtures or facility requirements recommended for servicing. The muffler, exhaust system, air cleaner, air compressor, starter, alternator, radiator, all accessories and any other component requiring service or replacement shall be easily removable and independent of the engine and transmission removal.
- (b) Belt guards shall be hinged on the streetside for ease of access from the curbside.
- (c) Oil pressure and coolant temperature gauges shall be provided in the engine compartment. These gauges shall be water proof, easily read during service and mounted in an area where they shall not be damaged during minor or major repairs.
- (d) Engine oil and the radiator filler caps shall be hinged to the filler neck and closed with spring pressure or positive locks to prevent leakage. All fluid fill locations shall be properly labeled to help ensure that correct fluid is added. All fillers shall be easily accessible with standard funnels, pour spouts and automatic dispensing equipment. All lubricant sumps shall be fitted with magnetic-type drain plugs.
- (e) The engine and transmission shall be equipped with sufficient heavy-duty fuel and oil filters for efficient operation and to protect the engine and transmission between scheduled filter changes. All filters shall be easily accessible and the filter bases shall be plumbed to ensure correct reinstallation.
- (f) Engine Air Cleaner:
 - (i) An air cleaner with dry primary and secondary filter elements. A graduated air filter restriction indicator shall be provided. The location of the air intake system shall be designed to minimize the entry of dust and debris and to maximize the life of the air filter. The engine air duct shall be designed to minimize the entry of water into the air intake system. Drainage provisions shall be included to allow any water/moisture to drain prior to entry into air filter.

E2.50 Referencing APTA Guideline TS 15. Hydraulic Systems:

- (a) Hydraulic system service tasks shall be minimized and scheduled no more frequently than those of other major coach systems. All elements of the hydraulic system shall be easily accessible for service or unit replacement. Critical points in the hydraulic system shall be fitted with service ports so that portable diagnostic equipment may be connected or sensors for an off-board diagnostic system permanently attached to monitor system operation when applicable. A tamper-proof priority system shall prevent the loss of power steering during operation of the bus if other devices are also powered by the hydraulic system. The hydraulic system shall operate within the allowable temperature range as specified by the lubricant shall be **15W-40** manufacturer.
- (b) There is no requirement for hydraulic system sensors.

E2.51 Referencing APTA Guideline TS 15.1 Fluid Lines:

- (a) All lines shall be rigidly supported to prevent chafing damage, fatigue failures, degradation and tension strain. Lines should be sufficiently flexible to minimize mechanical loads on the components. Lines passing through a panel, frame or bulkhead shall be protected by grommets (or similar devices) that fit snugly to both the line and the perimeter of the hole that the line passes through to prevent chafing and wear. Pipes and fluid hoses shall not be bundled with or used to support electrical wire harnesses.
- (b) Lines shall be as short as practicable and shall be routed or shielded so that failure of a line shall not allow the contents to spray or drain onto any component operable above the auto- ignition temperature of the fluid. All hoses, pipes, lines and fittings shall be specified and installed per the manufacturer's recommendations.

E2.52 Referencing APTA Guideline TS 15.2 Fittings and Clamps:

- (a) All clamps shall be **maintenance free, stainless steel, maintain a constant torque, with bevel spring mechanism**, expanding and contracting with the line in response to temperature changes and aging of the line material. The lines shall be designed for use in the environment where they are installed. For example, high-temperature resistant in the engine compartment, resistant to road salts near the road surface, and so on.
- (b) Compression fittings shall be standardized to prevent the intermixing of components. Compression fitting components from more than one manufacturer shall not be mixed, even if the components are known to be interchangeable.

E2.53 Referencing APTA Guideline TS 15.3 Charge Air Piping:

- (a) Charge air piping and fittings shall be designed to minimize air restrictions and leaks. Piping shall be as short as possible, and the number of bends shall be minimized. Bend radii shall be maximized to meet the pressure drop and temperature rise requirements of the engine manufacturer. The cross-section of all charge air piping shall not be less than the cross- section of the intake manifold inlet. Any changes in pipe diameter shall be gradual to ensure a smooth passage of air and to minimize restrictions. Piping shall be routed away from heat sources as practicable and shielded as required to meet the temperature rise requirements of the engine manufacturer.
- (b) Charge air piping shall be constructed of stainless steel, aluminized steel or anodized aluminum. Connections between all charge air piping sections shall be sealed with a short section of reinforced hose, impervious to all bus fluids, and secured with stainless steel constant tension clamps that provide a complete 360-degree seal.

E2.54 Referencing APTA Guideline TS 16. Radiator:

- (a) Radiator piping, within 36 inches of the ground, shall be stainless steel or brass tubing, and if practicable, hoses shall be eliminated. Necessary hoses shall be impervious to all bus fluids. All hoses shall be secured with **maintenance free, stainless steel, maintain a constant torque, with bevel spring mechanism** clamps that provide a complete 360-degree seal. The clamps shall maintain a constant tension at all times, expanding and contracting with the hose in response to temperature changes and aging of the hose material.

E2.55 Referencing APTA Guideline TS 16. Oil and Hydraulic Lines:

- (a) Oil and hydraulic lines shall be compatible with the substances they carry. The lines shall be designed and intended for use in the environment where they are installed. For example, high-temperature resistant in the engine compartment, resistant to road salts near the road surface, and so on. Lines within the engine compartment shall be composed of steel tubing where practicable, except in locations where flexible lines are required.
- (b) Hydraulic lines of the same size and with the same fittings as those on other piping systems of the bus, but not interchangeable, shall be tagged or marked for use on the hydraulic system only.
- (c) **Must be Eaton's Aeroquip products.**

E2.56 Referencing APTA Guideline TS 18.1 Fuel Lines:

- (a) Fuel lines shall be securely mounted, braced and supported as designed by the bus manufacturer to minimize vibration and chafing and shall be protected against damage, corrosion or breakage due to strain or wear.
- (b) Manifolds connecting fuel containers shall be designed and fabricated to minimize vibration and shall be installed in protected locations to prevent line or manifold damage from unsecured objects or road debris.
- (c) Fuel hose and hose connections, where permitted, shall be made from materials resistant to corrosion and fuel and protected from fretting and high heat. Fuel hoses shall be accessible for ease of serviceability.
- (d) **Quick disconnects fittings are not permitted.**
- (e) Fuel Lines, Diesel:
 - (i) Fuel lines shall be securely mounted, braced and supported using "split-block" type or stainless steel P clamps; all mounting clamps shall be mounted to a rigid structure to minimize vibration and shall be protected against damage, corrosion or breakage due to strain, rubbing, or wear. "Floating clamps" (not mounted to a rigid structure) shall not be permitted. Fuel lines shall not be used to secure other components (wires, air lines, etc).
 - (ii) Manifolds connecting fuel containers shall be designed and fabricated to minimize vibration and shall be installed in protected location(s) to prevent line or manifold damage from unsecured objects or road debris.
 - (iii) The fuel lines forward of the engine bulkhead shall be in conformance to SAE standards.

E2.57 Referencing APTA Guideline TS 18.2.1 Design and Construction, Diesel:

- (a) Fuel Tank(s):
 - (i) The fuel tank(s) shall be made of high-density cross-linked polyethylene plastic material.
- (b) Installation:
 - (i) The fuel tank(s) shall be securely mounted to the bus to prevent movement during bus maneuvers.
 - (ii) The fuel tank(s) must have fuel level system.
 - (iii) The fuel tank(s) shall be equipped with an external, hex head, drain plug. It shall be at least a 3/8-inch size and shall be located at the lowest point of the tank(s). The fuel tank(s) shall have an inspection plate or easily removable filler neck to permit cleaning and inspection of the tank(s) **and level sensors** without removal from the bus **or damage/deformation of filler neck or sensor**. The tank(s) shall be baffled internally to prevent fuel-sloshing noise regardless of fill level. The baffles or fuel pickup location shall assure continuous full power operation on a 6 percent upgrade for 15 minutes starting with no more than 95 litres of fuel over the unusable amount in the tank(s). The bus shall operate at idle on a 6 percent downgrade for 30 minutes starting with no more than 38 litres of fuel over the unusable amount in the tank(s).

- (iv) The materials used in mounting shall withstand the adverse effects of road salts, fuel oils, and accumulation of ice and snow for the life of the bus.
- (c) Labeling:
 - (i) The capacity, date of manufacture, manufacturer name, location of manufacture, and certification of compliance to Federal Motor Carrier Safety Regulation shall be permanently marked on the fuel tank(s). The markings shall be readily visible and shall not be covered with an undercoating material.
- (d) Fuel Filler:
 - (i) The fuel filler shall be located 7 to 32 feet behind the centerline of the front door on the curb side of the bus. The filler cap shall be retained to prevent loss and shall be recessed into the body so that spilled fuel will not run onto the outside surface of the bus.
- (e) Dry-break fuel filler:
 - (i) The fuel filler shall accommodate a nozzle that forms a locked and sealed connection during the refueling process to eliminate spills. Fuel shall not be allowed to flow into the tank unless the nozzle has been properly coupled, locked and sealed to the filler. With the nozzle open, fuel shall enter the tank at a fill rate of not less than 150 litres per minute of foam-free fuel without causing the nozzle to shut off before the tank is full. The nozzle shall automatically shut off when the tank is essentially full. Once disconnected, fuel shall not be allowed to flow through the nozzle at any time. Any pressure over 3 psi shall be relieved from the fuel tank automatically. An audible signal shall indicate when the tank is essentially full. The dry break system shall be compatible with the City's system. The fuel filler cap shall be hinged.

E2.58 Referencing APTA Guideline TS 19.1 Exhaust Emissions:

- (a) The engine and related systems shall meet all applicable emission and engine design guidelines and standards.

E2.59 Referencing APTA Guideline TS 19.2 Exhaust System:

- (a) Exhaust gases and waste heat shall be discharged from the roadside rear corner of the roof. The exhaust pipe shall be of sufficient height to prevent exhaust gases and waste heat from discoloring or causing heat deformation to the bus. The entire exhaust system shall be adequately shielded to prevent heat damage to any bus component, including the exhaust after-treatment compartment area. The exhaust tailpipe orientation shall be straight up with no rain cap.

E2.60 Referencing APTA Guideline TS 19.3 Exhaust After-Treatment:

- (a) The bus must be equipped with all components required by the engine manufacturer to meet all applicable EPA regulations.
- (b) Diesel Exhaust Fluid Injection:
 - (i) If required by the engine manufacturer to meet NOx level requirements specified by EPA, a DEF injection system will be provided. The DEF system will minimally include a tank, an injector, a pump, an ECM and a selective catalytic converter. The tanks shall be designed to store DEF in the operating environment described in the "Operating Environment" section. The DEF fluid lines shall be designed to prevent the DEF from freezing. The DEF injection system shall not be damaged from a cold soak at -12 °C.
 - (ii) The DEF filler shall accommodate a nozzle that forms a locked and sealed connection during the refueling process to eliminate spills. The nozzle shall be a Parker Hannifin part #FS-502-8FP-E5DEF or City approved equivalent. With the nozzle open, DEF shall enter the tank at a fill rate of not less than 22 litres per minute without causing the nozzle to shut off before the tank is 85 percent full. The nozzle shall automatically shut off when the tank is essentially 85 percent full. Once

disconnected, fluid shall not be allowed to flow through the nozzle at any time. The filler cap shall be installed on the receiver.

(c) DEF Filler Interlock:

- (i) The DEF filler access door shall have a proximity switch that will engage the brake interlock when the door is open. This system shall be designed to prevent the bus from moving while the DEF filler hose is still attached.

E2.61 Referencing APTA Guideline TS 20.1 Structural Design:

- (a) The structure of the bus shall be designed to withstand the transit service conditions typical of an urban duty cycle throughout its service life. The vehicle structural frame shall be designed to operate with minimal maintenance throughout the **18-year** service profile. The design operating profile specified by the City shall be considered for this purpose.

E2.62 Referencing APTA Guideline TS 21.1. Structural Validation:

- (a) Proposed vehicle must have completed any FTA-required Altoona testing and Finite Element Analysis (FEA).
- (b) The completed test reports shall be provided with the proposal submittal. The bus model tested shall match the bus model proposed for procurement, including structure, axles and drive-train. Any subsequent structural changes shall require complete test reports and must be submitted prior each build pre-production meeting.
- (c) Any items that required repeated repairs or replacement must undergo the corrective action with supporting test and analysis. A report clearly describing and explaining the failures and corrective actions taken to ensure any and all such failures will not occur shall be submitted to the City for approval.

E2.63 Referencing APTA Guideline TS 22. Distortion:

- (a) The bus, loaded to GVWR and under static conditions, shall not exhibit deflection or deformation that impairs the operation of the steering mechanism, doors, windows, passenger escape mechanisms or service doors. Static conditions shall include the vehicle at rest with any one wheel or dual set of wheels on a 6 in. curb or in a 6 in. deep hole.

E2.64 Referencing APTA Guideline TS 23. Resonance and Vibration:

- (a) All structure, body and panel-bending mode frequencies, including vertical, lateral and torsional modes, shall be sufficiently removed from all primary excitation frequencies to minimize audible, visible or sensible resonant vibrations during normal service.

E2.65 Referencing APTA Guideline TS 23.1 Engine Compartment Bulkheads:

- (a) The passenger and engine compartment shall be separated by fire-resistant bulkheads. The engine compartment shall include areas where the engine and exhaust system are housed. This bulkhead shall preclude or retard propagation of an engine compartment fire into the passenger compartment and shall be in accordance with the Recommended Fire Safety Practices defined in FTA Docket 90A, dated October 20, 1993. Only necessary openings shall be allowed in the bulkhead, and these shall be fire-resistant. Any passageways for the climate control system air shall be separated from the engine compartment by fire-resistant material. Piping through the bulkhead shall have fire-resistant fittings sealed at the bulkhead. Wiring may pass through the bulkhead only if connectors or other means are provided to prevent or retard fire propagation through the bulkhead. Engine access panels in the bulkhead shall be fabricated of fire-resistant material and secured with fire-resistant fasteners. These panels, their fasteners and the bulkhead shall be constructed and reinforced to minimize warping of the panels during a fire that will compromise the integrity of the bulkhead.

E2.66 Referencing APTA Guideline TS 23.2 Crashworthiness:

- (a) The bus body and roof structure shall withstand a static load equal to 150 percent of the curb weight evenly distributed on the roof with no more than a 6 in. reduction in any interior dimension. Windows shall remain in place and shall not open under such a load. These requirements must be met without the roof-mounted equipment installed.
- (b) The bus shall withstand a 40 km/h impact by an 1800 kg automobile at any side, excluding doorways, along either side of the bus with no more than 3 in. of permanent structural deformation at seated passenger hip height. This impact shall not result in sharp edges or protrusions in the bus interior.
- (c) Exterior panels below 35 inches from ground level shall withstand a static load of 907 kg applied perpendicular to the bus by a pad no larger than 5 square inches. This load shall not result in deformation that prevents installation of new exterior panels to restore the original appearance of the bus.

E2.67 Referencing APTA Guideline TS 24. Corrosion:

- (a) The bus flooring, sides, roof, under-structure and axle suspension components shall be designed to resist corrosion or deterioration from atmospheric conditions and all de-icing materials for a period of 18 years or 1,200,000 kilometres, whichever comes first. It shall maintain structural integrity and nearly maintain original appearance throughout its service life.
- (b) All materials that are not inherently corrosion resistant shall be protected with corrosion-resistant coatings. All joints and connections of dissimilar metals shall be corrosion resistant and shall be protected from galvanic corrosion. Representative samples of all materials and connections shall withstand a two-week (336-hour) salt spray test in accordance with ASTM Procedure B-117 with no structural detrimental effects to normally visible surfaces and no weight loss of over 1 percent.
- (c) **Corrosion Resistance Requirements for Exposed and Interior Surfaces of Tubing throughout Entire Vehicle:**
 - (i) **All exposed surfaces and the interior surfaces of tubing and other enclosed members shall be corrosion resistant through application of a corrosion protection system.**

E2.68 Referencing APTA Guideline TS 25. Towing:

- (a) Each towing device shall withstand, without permanent deformation, tension loads up to 1.2 times the curb weight of the bus within 20 degrees of the longitudinal axis of the bus. The rear towing device(s) shall not provide a toehold for unauthorized riders. The method of attaching the towing device shall not require the removal, or disconnection, of front suspension or steering components. Removal of the bike rack is permitted for attachment of towing devices.
- (b) **Bike Rack:**
 - (i) **Must have a Sportworks Apex 2 bike rack.**
- (c) A plug connector permanently mounted at the front of the bus, by the street side headlight, shall provide for bus tail lamp, marker, stop and turn signal lamp operation as controlled from the towing vehicle. The connector shall be Cole Hersee Part # CH 1235 or City approved other. The connector shall include a spring-loaded dust- and water-resistant cap. Shop air connectors shall be provided at the front and rear of the bus and shall be capable of supplying all pneumatic systems of the bus with externally sourced compressed air. The location of these shop air connectors shall facilitate towing operations.
- (d) **Lifted (Unsupported) Front Axle Towing Capability:**
 - (i) The front towing devices shall allow attachment of adapters for a rigid tow bar and shall permit the lifting and towing of the bus, at curb weight, while the front wheels are clear off the ground.
- (e) **Flat Towing Capability:**
 - (i) Common flat towing shall be accommodated by tow rings above the front bumper.

- (f) Two rear recovery devices/tie downs shall permit lifting and towing of the bus for a short distance, such as in cases of an emergency, to allow access to provisions for front towing of bus. The method of attaching the tow bar or adapter shall require the specific approval of the City. Any tow bar or adapter exceeding 50 lbs. should have means to maneuver or allow for ease of use and application. Each towing device shall accommodate a crane hook with a 1 inch throat.

E2.69 Referencing APTA Guideline TS 26. Jacking:

- (a) It shall be possible to safely jack up the bus, at curb weight, with a common 10-ton floor jack with or without special adapter, when a tire or dual set is completely flat and the bus is on a level, hard surface, without crawling under any portion of the bus. Jacking from a single point shall permit raising the bus sufficiently high to remove and reinstall a wheel and tire assembly. Jacking pads located on the axle or suspension near the wheels shall permit easy and safe jacking with the flat tire or dual set on a 6 inch high run-up block not wider than a single tire. The bus shall withstand such jacking at any one or any combination of wheel locations without permanent deformation or damage.
- (b) Jacking Pads:
 - (i) Jacking pads shall be painted **safety yellow**. Jack pads must be 6.25" x 6.25" outside with 5.25" x 5.25" internal square.

E2.70 Referencing APTA Guideline TS 27. Hoisting:

- (a) **The bus axles shall accommodate the lifting pads of a two-post hoist system with Front Rotary Hoist Adapter part #RTRY FD2389YLSPL and Rear Rotary Hoist Adapter Part #RTRY FD2347YLSPL. The Other pads or the bus structure shall support the bus on jack stands independent of the hoist.**

E2.71 Referencing APTA Guideline TS 28.1 Floor Design:

- (a) The floor shall be essentially a continuous plane, except at the wheel housings and platforms. Where the floor meets the walls of the bus, as well as other vertical surfaces such as platform risers, the surface edges shall be blended with a circular section of radius not less than ¼ in. or installed in a fully sealed butt joint. Similarly, a molding or cover shall prevent debris accumulation between the floor and wheel housings. The vehicle floor in the area of the entrance and exit doors shall have a lateral slope not exceeding 2 degrees to allow for drainage.
- (b) **If trim is used at any door floor area, it must be 304 stainless steel with stainless steel hardware.**
- (c) Bi-level Floor Design:
 - (i) The floor design shall consist of two levels (bi-level construction). Aft of the rear door extending to the rear settee riser, the floor height may be raised to a height no more than 21 inches above the lower level, with equally spaced steps. An increase slope shall be allowed on the upper level, not to exceed 3.5 degrees off the horizontal.
- (d) Floor Drain:
 - (i) Floor drains, of noncorrosive materials, shall be provided on the bus behind the front street side and curb side wheelhouse near the wall to help drain any water that may accumulate due to ice, snow, rain, etc. The drain pipe shall be approximately 1½ inches in diameter and shall extend no more than 5 inches below the floor. The drain pipe shall be fitted with a rubber drain spout to minimize or prevent air drafts to the interior of the bus. The strainer shall be firmly retained but also removable to allow flushing of any accumulated debris.
- (e) Horizontal movement and designed to last the life of the bus. Sheet metal screws shall not be used to retain the floor, and all floor fasteners shall be serviceable from one side only. Any adhesives, bolts or screws used to secure the floor to the structure shall last and remain effective throughout the life of the coach. Tapping plates, if used for the floor fasteners, shall be no less than the same thickness as a standard nut, and all floor fasteners shall be secured and protected from corrosion for the service life of the bus.

- (f) The floor deck shall be reinforced as needed to support passenger loads. At GVWR, the floor shall have an elastic deflection of no more than 0.60 inches from the normal plane. The floor shall withstand the application of 2.5 times gross load weight without permanent detrimental

E2.72 Referencing APTA Guideline TS 28.4 Floor Strength:

- (a) The floor deck may be integral with the basic structure or mounted on the structure securely to prevent chafing or deformation. The floor, with coverings applied, shall withstand a static load of at least 150 lbs applied through the flat end of a ½ inch diameter rod, with 1/32-inch radius, without permanent visible deformation.

E2.73 Referencing APTA Guideline TS 28.5 Floor Construction:

- (a) The floor shall consist of the subfloor and the floor covering that will last the life of the bus. The floor as assembled, including the sealer, attachments and covering shall be waterproof, non- hygroscopic and resistant to mold growth. The subfloor shall be resistant to the effects of moisture, including decay (dry rot). It shall be impervious to wood-destroying insects such as termites.
- (b) OPTION 1:
 - (i) Pressure-Preserved Plywood Panel. Plywood shall be certified at the time of manufacturing by an industry-approved third- party inspection agency such as APA – The Engineered Wood Association (formerly the American Plywood Association). Plywood shall be of a thickness adequate to support design loads, manufactured with exterior glue, satisfy the requirements of a Group I Western panel as defined in PS 1-95 (Voluntary Product Standard PS 1-95, “Construction and Industrial Plywood”) and be of a grade that is manufactured with a solid face and back. Plywood shall be installed with the highest-grade, veneer side up. Plywood shall be pressure-treated with a preservative chemical and process such as alkaline copper quaternary (ACQ) that prevents decay and damage by insects. Preservative treatments shall utilize no EPA-listed hazardous chemicals. The concentration of preservative chemicals shall be equal to or greater than required for an above ground level application. Treated plywood will be certified for preservative penetration and retention by a third party inspection agency. Pressure-preservative treated plywood shall have moisture content at or below 15 percent.
- (c) OPTION 2:
 - (i) Composite Flooring. Sub-flooring shall composed ¾ inch thick honeycomb impregnated paper board phenolic structure filled with polyurethane foam and covered with bonded fiberglass sheets on both sides.

E2.74 Referencing APTA Guideline TS 29.1 Operator’s Area:

- (a) The covering of platform surfaces and risers, except where otherwise indicated, shall be the same material as specified for floor covering. Trim shall be provided along top edges of platforms unless integral nosing is provided.
- (b) Stainless steel trim material with stainless thermal spray anti slip surface complying with ASTM A967.

E2.75 Referencing APTA Guideline TS 29.2 Operator’s Platform:

- (a) The operator’s platform shall be of a height such that, in a seated position, the operator can see an object located at an elevation of 42 inches above the road surface, 24 inches from the leading edge of the bumper. Notwithstanding this requirement, the platform height shall not position the operator such that the operator’s vertical upward view is less than 15 degrees. A warning decal or sign shall be provided to alert the operator to the change in floor level. Figure 2 illustrates a means by which the platform height can be determined, using the critical line of sight.

(b) Figure 2.

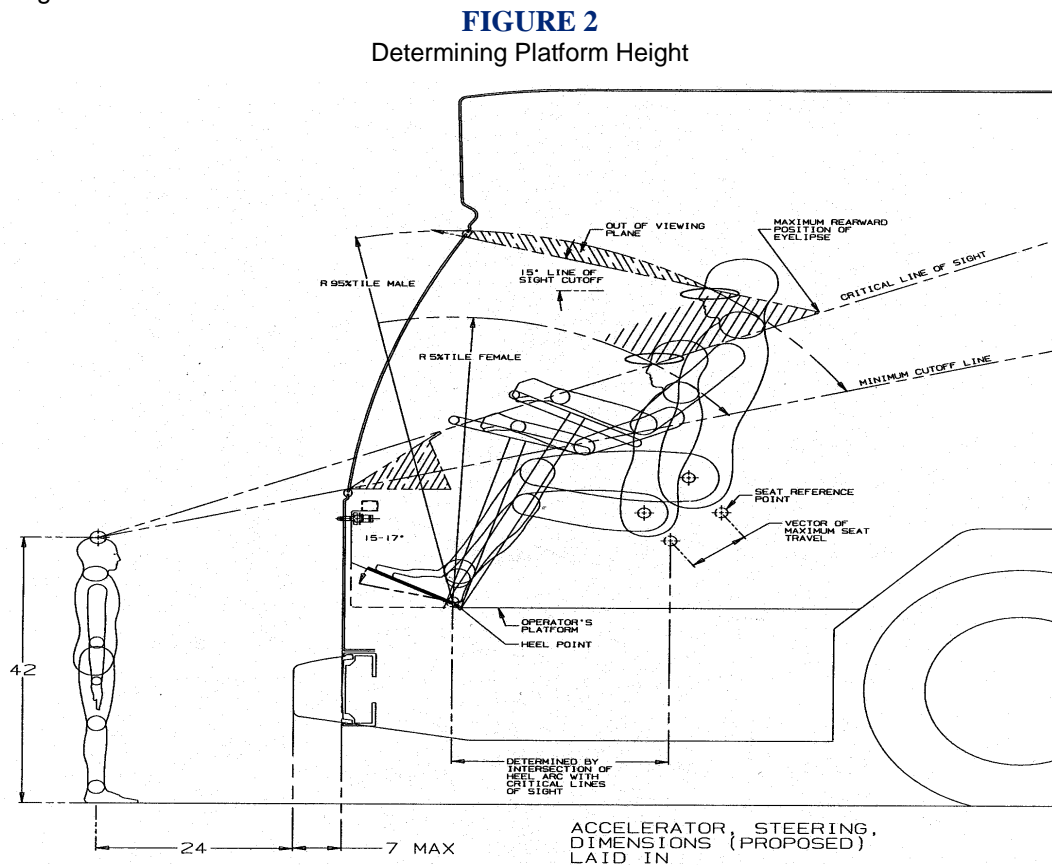

E2.76 Referencing APTA Guideline TS 29.3 Farebox:

- (a) Must provide mounting structure for floor mounted farebox base and 24 volt power supply. Farebox location is determined by City. No mounting platform.

E2.77 Referencing APTA Guideline TS 29.4 Rear Step Area to Rear Area:

- (a) If the vehicle is of a bi-level floor design, a rear step area shall be provided along the center aisle of the bus to facilitate passenger traffic between the upper and lower floor levels. This step area shall be cut into the rear platform and shall be approximately the aisle width, a minimum 12 inches deep and approximately half the height of the upper level relative to the lower level. The horizontal surface of this platform shall be covered with skid-resistant material with a visually contrasting nosing and shall be sloped slightly for drainage. A warning decal or sign shall be provided at the immediate platform area to alert passengers to the change in floor level.

E2.78 Referencing APTA Guideline TS 30.1 Wheel Housing Design and Construction:

- (a) Sufficient clearance and air circulation shall be provided around the tires, wheels and brakes to preclude overheating when the bus is operating on the design operating profile. Wheel housings shall be constructed of corrosion-resistant and fire-resistant material.
- (b) Interference between the tires and any portion of the bus shall not be possible in maneuvers up to the limit of tire adhesion with weights from curb weight to GVWR. Wheel housings shall be adequately reinforced where seat pedestals are installed. Wheel housing must isolate passenger compartment from catastrophic tire failure. Wheel housings shall have sufficient sound insulation to minimize tire and road noise and meet all noise requirements of this specification.

- (c) Design and construction of front wheel housings shall allow for the installation of a radio or electronic equipment storage compartment on the interior top surface, or its use as a luggage rack.
- (d) The finish of the front wheel housings shall be scuff-resistant coating and complement interior finishes of the bus to minimize the visual impact of the wheel housing. If fiberglass wheel housings are provided, then they shall be color-impregnated to match interior finishes. The lower portion extending to approximately 10 to 12 inches above floor shall be equipped with stainless steel trim and hardware.
- (e) Wheel housings, as installed and trimmed, shall withstand impacts of a 2 inches steel ball with at least 200 ft-lbs of energy without penetration. Wheel housings not equipped with seats or equipment enclosure shall have a horizontal assist mounted on the top portion of the housing no more than 4.75 inches higher than the wheel well housing.

REFERENCING APTA GUIDELINE TS 31 SUSPENSION (CHASSIS)

E2.79 Referencing APTA Guideline TS 31.1 General Requirements:

- (a) The front, rear and mid (if articulated) suspensions shall be pneumatic type. The basic suspension system, including:
 - (i) Foundation components, shall last the service life of the bus without major overhaul or replacement (excludes wear items). Adjustment points shall be minimized and shall not be subject to a loss of adjustment in service. Routine adjustments shall be easily accomplished by limiting the removal or disconnecting the components.
 - (ii) Wear Items are defined as bushings, shock absorbers and bellows. Radius Rods shall be non-windowed

E2.80 Referencing APTA Guideline TS 31.2 Alignment:

- (a) All axles should be properly aligned so the vehicle tracks accurately within the size and geometry of the vehicle.

REFERENCING APTA GUIDELINE TS 31.3 SPRINGS AND SHOCK ABSORBERS

E2.81 Referencing APTA Guideline TS 31.3.1 Suspension Travel:

- (a) The suspension system shall permit a minimum wheel travel of 2.75 inches jounce-upward travel of a wheel when the bus hits a bump (higher than street surface), and 2.75 inches rebound-downward travel when the bus comes off a bump and the wheels fall relative to the body. Elastomeric bumpers shall be provided at the limit of jounce travel. Rebound travel may be limited by elastomeric bumpers or hydraulically within the shock absorbers. Suspensions shall incorporate appropriate devices for automatic height control so that regardless of load the bus height relative to the centerline of the wheels does not change more than ½ inch at any point from the height required. The safe operation of a bus cannot be impacted by ride height up to 1 inch from design normal ride height.
- (b) **Shock absorbers must be easily serviceable and meets City's approval.**

E2.82 Referencing APTA Guideline TS 31.3.2 Damping:

- (a) Vertical damping of the suspension system shall be accomplished by hydraulic shock absorbers mounted to the suspension arms or axles and attached to an appropriate location on the chassis. Damping shall be sufficient to control coach motion to three cycles or less after hitting road perturbations. The shock absorber bushing shall be made of elastomeric material that will last the life of the shock absorber. The damper shall incorporate a secondary hydraulic rebound stop.

E2.83 Referencing APTA Guideline TS 31.3.3 Lubrication: Standard Grease Fittings

- (a) All elements of steering, suspension and drive systems requiring scheduled lubrication shall be provided with grease fittings conforming to SAE Standard J534. These fittings shall be located for ease of inspection and shall be accessible with a standard grease gun from a pit or with the bus on a hoist. For each element requiring lubrication shall have its own grease fitting with a relief path. The lubricant specified shall be standard for all elements on the bus serviced by standard fittings and shall be required no less than every 9600 kilometres

E2.84 Referencing APTA Guideline TS 31.3.4 Kneeling:

- (a) A kneeling system shall lower the entrance(s) of the bus a minimum of 2.5 in. during loading or unloading operations regardless of load up to GVWR, measured at the longitudinal centerline of the entrance door(s) by the operator. The kneeling control shall provide the following functions:
 - (i) downward control must be held to allow downward kneeling movement;
 - (ii) release of the control during downward movement must completely stop the lowering motion and hold the height of the bus at that position; and
 - (iii) upward control actuation must allow the bus to return to normal floor height without the operator having to hold the control.
- (b) The brake and throttle interlock shall prevent movement when the bus is kneeled. The kneeling control shall be disabled when the bus is in motion. The bus shall kneel at a maximum rate of 1.25 inches per second at essentially a constant rate. After kneeling, the bus shall rise within 3 seconds to a height permitting the bus to resume service and shall rise to the correct operating height within 7 seconds regardless of load up to GVWR. During the lowering and raising operation, the maximum vertical acceleration shall not exceed 0.2g, and the jerk shall not exceed 0.3g/second.
- (c) An indicator visible to the operator shall be illuminated until the bus is raised to a height adequate for safe street travel. An audible warning alarm will sound simultaneously with the operation of the kneeler to alert passengers and bystanders. A warning light mounted near the curbside of the front door, a minimum 2.5 inches diameter amber lens, shall be provided that will blink when the kneel feature is activated. Kneeling shall not be operational while the wheelchair ramp is deployed or in operation. Kneeling shall be functional in all front door control positions.

E2.85 Referencing APTA Guideline TS 32.1 Wheels:

- (a) All wheels shall be interchangeable and shall be removable without a puller. Wheels shall be compatible with tires in size and load-carrying capacity. Front wheels and tires shall be balanced as an assembly per SAE J1986.
- (b) Painted Steel:
 - (i) Wheels and rims shall be hub-piloted with powder coated steel (maximum 3.5 mil) and shall resist rim flange wear.

E2.86 Referencing APTA Guideline TS 32.2 Tires:

- (a) The tires shall be supplied by the City. All supply coordination shall be done thru the City. The City will supply City approved valve stems.**
- (b) Tires must be balanced to industry standards.**

E2.87 Referencing APTA Guideline TS 33. Steering:

- (a) Hydraulically assisted steering shall be provided. The steering gear shall be an integral type with the number and length of flexible lines minimized or eliminated. Engine driven hydraulic pump shall be provided for power steering.

E2.88 Referencing APTA Guideline TS 33.1 Steering Axle:

- (a) Solid Beam Axle and Grease-Type Front Bearings and Seals:
 - (i) The front axle shall be solid beam, non-driving with a load rating sufficient for the bus loaded to GVWR and shall be equipped with grease type front wheel bearings and seals.
- (b) All friction points on the front axle shall be equipped with replaceable bushings or inserts and, if needed, lubrication fittings easily accessible from a pit or hoist.
- (c) The steering geometry of the outside (front lock) wheel shall be within 2 degrees of true Ackerman up to 50 percent lock measured at the inside (back lock) wheel. The steering geometry shall be within 3 degrees of true Ackerman for the remaining 100 percent lock measured at the inside (back lock) wheel.

E2.89 Referencing APTA Guideline TS 33.3.2 Turning Effort:

- (a) Steering effort shall be measured with the bus at GVWR, stopped with the brakes released and the engine at normal idling speed on clean, dry, level, commercial asphalt pavement and the tires inflated to recommended pressure.
- (b) Under these conditions, the torque required to turn the steering wheel 10 degrees shall be no less than 5 ft.-lbs and no more than 10 ft.-lbs. Steering torque may increase to 70 ft.-lbs when the wheels are approaching the steering stops, as the relief valve activates.
- (c) Power steering failure shall not result in loss of steering control. With the bus in operation, the steering effort shall not exceed 55 lbs at the steering wheel rim, and perceived free play in the steering system shall not materially increase as a result of power assist failure. Gearing shall require no more than seven turns of the steering wheel lock-to-lock.
- (d) Caster angle shall be selected to provide the return of the front wheels to the straight position with minimal assistance from the operator.

E2.90 Referencing APTA Guideline TS 33.3.2 Steering Wheel, General:

- (a) The steering wheel diameter shall be approximately 18-20 inches; the rim diameter shall be $\frac{7}{8}$ inch to $1\frac{1}{4}$ inch and shaped for firm grip with comfort for long periods of time. The steering wheel shall be a hard molded anti-vandal surface.
- (b) Steering wheel spokes and wheel thickness shall ensure visibility of the dashboard so that vital instrumentation is clearly visible at center neutral position (within the range of a 95th-percentile male, as described in SAE 1050a, Sections 4.2.2 and 4.2.3). Placement of steering column must be as far forward as possible, but either in line with or behind the instrument cluster.

E2.91 Referencing APTA Guideline TS 33.3.3 Steering Column Tilt:

- (a) The steering column shall have full tilt capability with an adjustment range of no less than 40 degrees from the vertical and easily adjustable by the operator.

E2.92 Referencing APTA Guideline TS 33.3.4 Steering Wheel Telescopic Adjustment:

- (a) The steering wheel shall have full telescoping capability and have a minimum telescopic range of 2 inches and a minimum low-end adjustment of 29 inches, measured from the top of the steering wheel rim in the horizontal position to the cab floor at the heel point.

(b) Table 4.

TABLE 4 Steering Wheel Height Relative to Angle of Slope			
At Minimum Telescopic Height Adjustment (29 in.)		At Maximum Telescopic Height Adjustment (5 in.)	
Angle of Slope	Height	Angle of slope	Height
0 deg.	29 in.	0 deg.	34 in.
15 deg.	26.2 in.	15 deg.	31.2 in.
25 deg.	24.6 in.	25 deg.	29.6 in.
35 deg.	22.5 in.	35 deg.	27.5 in.
Measured from bottom portion closest to driver.			

E2.93 Referencing APTA Guideline TS 34. Drive Axle:

- (a) The bus shall be driven by a heavy-duty axle with a load rating sufficient for the bus loaded to GVWR. The drive axle shall have a design life to operate for not less than 480,000 kilometres on the design operating profile without replacement or major repairs. The lubricant drain plug shall be magnetic type. If a planetary gear design is employed, the oil level in the planetary gears shall be easily checked through the plug or sight gauge. The axle and driveshaft components shall be rated for both propulsion and retardation modes with respect to duty cycle.
 - (i) NOTE: The retardation duty cycle can be more aggressive than propulsion.
- (b) The drive shaft shall be guarded to prevent hitting any critical systems, including brake lines, coach floor or the ground, in the event of a tube or universal joint failure.

E2.94 Referencing APTA Guideline TS 34. Turning Radius: Maximum Turning Radius:

(a) Table 5

Maximum Turning Radius

Bus Length (approximate)	Maximum Turning Radius (see Figure 3)	Agency Requirement
40 ft.	44 ft. (TR0)	
60 ft.	44.5ft (outside front axle, TR0) 17 ft. (inside rearmost axle, TR4)	

FIGURE 3
Turning Radius

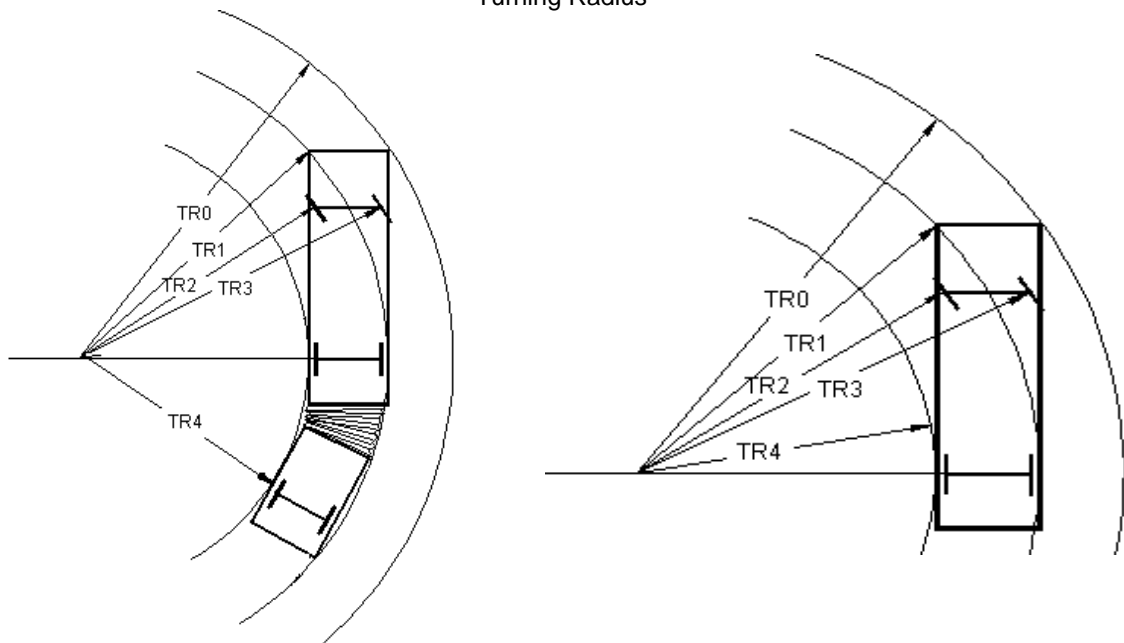

E2.95 Referencing APTA Guideline TS 37.1 Service Brake:

(a) Brakes shall be self-adjusting.

E2.96 Referencing APTA Guideline TS 37.2 Actuation:

(a) Air-Actuated Brakes:

(i) Service brakes shall be controlled and actuated by a compressed air system. Force to activate the brake pedal control shall be an essentially linear function of the bus deceleration rate and shall not exceed 70 lbs at a point 7 inches above the heel point of the pedal to achieve maximum braking. The heel point is the location of the operator's heel when his or her foot is rested flat on the pedal and the heel is touching the floor or heel pad of the pedal. The ECU for the ABS system shall be protected, yet in an accessible location to allow for ease of service.

(b) The total braking effort shall be distributed between all wheels in such a ratio as to ensure equal friction material wear rate at all wheel locations. Manufacturer shall demonstrate compliance by providing a copy of a thermo dynamic brake balance test.

(c) No automatic traction control.

E2.97 Referencing APTA Guideline TS 37.3 Friction Material:

- (a) The brake pads shall be made of non-asbestos material. In order to aid maintenance personnel in determining extent of wear, a provision such as a scribe line or chamfer indicating the thickness at which replacement becomes necessary shall be provided on each brake pad. The brake pad wear indicator shall be clearly visible without any disassembly.

E2.98 Referencing APTA Guideline TS 37.4 Hubs and Drums/Disc:

- (a) Replaceable wheel bearing seals shall run on replaceable wear surfaces or be of an integral wear surface sealed design. Wheel bearing and hub seals and unitized hub assemblies shall not leak or weep lubricant when operating on the design operating profile for the duration of the initial manufacturer's warranty.
- (b) Disc Brakes on All Axles:
 - (i) The bus shall be equipped with disc brakes on all axles, and the brake discs shall allow machining of each side of the disc to obtain smooth surfaces per manufacturer's specifications.
- (c) The brake system material and design shall be selected to absorb and dissipate heat quickly so that the heat generated during braking operation does not glaze brake pads or warp brake discs.

E2.99 Referencing APTA Guideline TS 37.6 Parking/Emergency Brake:

- (a) Parking Brakes:
 - (i) The parking brake shall be a pull to apply spring-operated system, actuated by a valve that exhausts compressed air to apply the brakes. The parking brake may be manually enabled when the air pressure is at the operating level per FMVSS 121.
- (b) Emergency Brake:
 - (i) An emergency brake release shall be provided to release the brakes in the event of automatic emergency brake application. The operator shall be able to manually depress and hold down the emergency brake release valve to release the brakes and maneuver the bus to safety. Once the operator releases the emergency brake release valve, the brakes shall engage to hold the bus in place. **Air to the emergency brake release system shall be provided by a dedicated emergency air tank.**

E2.100 Referencing APTA Guideline TS 38.1 Passenger Door Interlocks:

- (a) To prevent opening rear passenger doors while the bus is in motion, a speed sensor shall be integrated with the door controls to prevent the rear doors from being enabled or opened unless the bus speed is 0 km/h.
- (b) To preclude movement of the bus, an accelerator interlock shall lock the accelerator in the closed position, and a brake interlock shall engage the service brake system to stop movement of the bus when the operator's door control is moved to a rear door enable or open position, or a rear door panel is opened more than 3 inches from the fully closed position (as measured at the leading edge of the door panel). The interlock engagement shall be capable of holding a fully loaded bus on a 6 percent grade, with the engine at idle and the transmission in gear, until the interlocks are released. These interlock functions shall be active whenever the vehicle Master Run Switch is in any run position.
- (c) All door systems employing brake and accelerator interlocks shall be supplied with supporting failure mode effects analysis (FEMA) documentation, which demonstrates that failure modes are of a failsafe type, thereby never allowing the possibility of release of interlock while an interlocked door is in and unsecured condition, unless the door master switch has been actuated to intentionally release the interlocks.
- (d) Non-adjustable brake interlock regulator.
- (e) There is no requirement for accelerator and brake interlocks when only front doors are opened.

E2.101 Referencing APTA Guideline TS 39.1 Pneumatic System General:

- (a) The bus air system shall operate the air-powered accessories and the braking system with reserve capacity. New buses shall not leak down more than 5 psi over a 15-minute period of time as indicated on the dash gauge.
- (b) Provision shall be made to apply shop air to the bus air systems. A quick disconnect fitting, compatible with City equipment (**ARO A-2608/Milton 777**), shall be easily accessible and located in the engine compartment and near the front bumper area for towing. Retained caps shall be installed to protect fitting against dirt and moisture when not in use. Air for the compressor shall be filtered. The air system shall be protected per FMVSS 121.

E2.102 Referencing APTA Guideline TS 39.2 Air Compressor:

- (a) The air compressor shall be sized (designed) to charge the entire air system from 0 psi to 125 psi in less than 4 minutes for a single unit bus while not exceeding the fast idle speed (~1000 rpm) setting of the engine. The air compressor governor shall be remote mounted in a location approved by the City.
- (b) The engine-driven air compressor shall be designed to supply air operating under the Air System Design Operating Profile while remaining within the manufactures air compressor specifications. The discharge temperature (measured at the compressor outlet using a probe thermocouple) shall not exceed 360°F, excluding temperature spikes of duration less than 2 seconds and 2% of compressor charge time.

E2.103 Referencing APTA Guideline TS 39.3 Air Lines and Fittings:

- (a) Air lines, except necessary flexible lines, shall conform to the installation and material requirements of SAE Standard J1149 for copper tubing with standard, brass, flared or ball sleeve fittings, or SAE Standard J844 for nylon tubing if not subject to temperatures over 200°F. The air on the delivery side of the compressor where it enters nylon housing shall not be above the maximum limits as stated in SAE J844. Nylon tubing shall be installed in accordance with the following color-coding standards:
 - (i) Green: Indicates primary brakes and supply;
 - (ii) Red: Indicates secondary brakes;
 - (iii) Brown: Indicates parking brake;
 - (iv) Yellow: Indicates compressor governor signal;
 - (v) Black: Indicates accessories; and
 - (vi) **Orange: Indicates fuel and must fuel grade.**
- (b) Line supports shall prevent movement, flexing, tension, strain, chafing and vibration. Copper lines shall be supported to prevent the lines from touching one another or any component of the bus. To the extent practicable and before installation, the lines shall be pre-bent on a fixture that prevents tube flattening or excessive local strain. Copper lines shall be bent only once at any point, including pre-bending and installation. Rigid lines shall be supported at no more than 5-ft intervals. Nylon lines may be grouped and shall be supported at 30 in. intervals or less.
- (c) The compressor discharge line between power plant and body-mounted equipment shall be flexible Teflon hose with a braided stainless steel jacket. All lines necessary to maintain system reliability shall be flexible Teflon hose with a braided stainless steel jacket. End fittings shall be standard SAE or JIC brass or steel, flanged, swivel-type fittings. Flexible hoses shall be as short as practicable and individually supported. They shall not touch one another or any part of the bus except for the supporting grommets. Flexible lines shall be supported at 2-ft intervals or less or as approved by the property inspector (The City).
- (d) Air lines shall be clean before installation and shall be installed to minimize air leaks. All air lines shall be routed to prevent water traps to the extent possible. Grommets or insulated clamps shall protect the air lines at all points where they pass through understructure components.

E2.104 Referencing APTA Guideline TS 39.4 Air Reservoirs:

- (a) All air reservoirs shall meet the requirements of FMVSS Standard 121 and SAE Standard J10 and shall be equipped with manually operated drain valves. Major structural members shall protect these valves and any automatic moisture ejector valves from road hazards. Reservoirs shall be sloped toward the drain valve. All air reservoirs shall have drain valves that discharge below floor level with lines routed to eliminate the possibility of water traps and/or freezing in the drain line.

E2.105 Referencing APTA Guideline TS 39.5 Air System Dryer:

- (a) **The dryer shall be a Haldex 24 volt "Gemini MDx" Tandem air dryer (includes Multi-Treatment Cartridge).**
- (b) The air dryer must be easily accessible for servicing; replacement of desiccant cartridges must not require removal of the dryer.
- (c) **Oil Separator:**
 - (i) **An oil separator must be located at the air dryer.**
 - (ii) **The air system shall be equipped with an air dryer located before the no. 1 air tank far enough from the compressor to provide sufficient air cooling to optimize air dryer efficiency (-40°C to 80°C). The air purge system shall have provisions to protect against freezing.**

ELECTRICAL, ELECTRONIC AND DATA COMMUNICATION SYSTEMS

E2.106 Referencing APTA Guideline TS 40. Overview:

- (a) The electrical system will consist of vehicle battery systems and components that generate, distribute and store power throughout the vehicle. (e.g., generator, voltage regulator, wiring, relays, and connectors).
- (b) Electronic devices are individual systems and components that process and store data, integrate electronic information or perform other specific functions.
- (c) The data communication system consists of the bi-directional communications networks that electronic devices use to share data with other electronic devices and systems. Communication networks are essential to integrating electronic functions, both onboard the vehicle and off.
- (d) **Battery voltage equalizer must be a Vanner 100 amp with J1939, voltage monitor and jump start override.**
- (e) Information level systems that require vehicle information for their operations or provide information shall adhere to J1939 data standard.
- (f) Data communications systems are divided into three levels to reflect the use of multiple data networks:
 - (i) **Drivetrain level:** Components related to the drivetrain including the propulsion system components (engine, transmission and hybrid units), and anti-lock braking system (ABS), which may include traction control;
 - (ii) **Information level:** Components whose primary function is the collection, control or display of data that is not necessary to the safe drivability of the vehicle (i.e., the vehicle will continue to operate when those functions are inoperable). These components typically consist of those required for automatic vehicle location (AVL) systems, destination signs, fareboxes, passenger counters, radio systems, automated voice and signage systems, video surveillance and similar components; and
 - (iii) **Multiplex level:** Electrical or electronic devices controlled through input/output signals such as discrete, analog and serial data information (i.e., on/off switch inputs, relay or relay control outputs). Multiplexing is used to control components not typically found on the drivetrain or information levels, such as lights; wheelchair lifts; doors; heating, ventilation and air conditioning (HVAC) systems (if applicable); and gateway devices.

(g) Data Communications Systems Levels

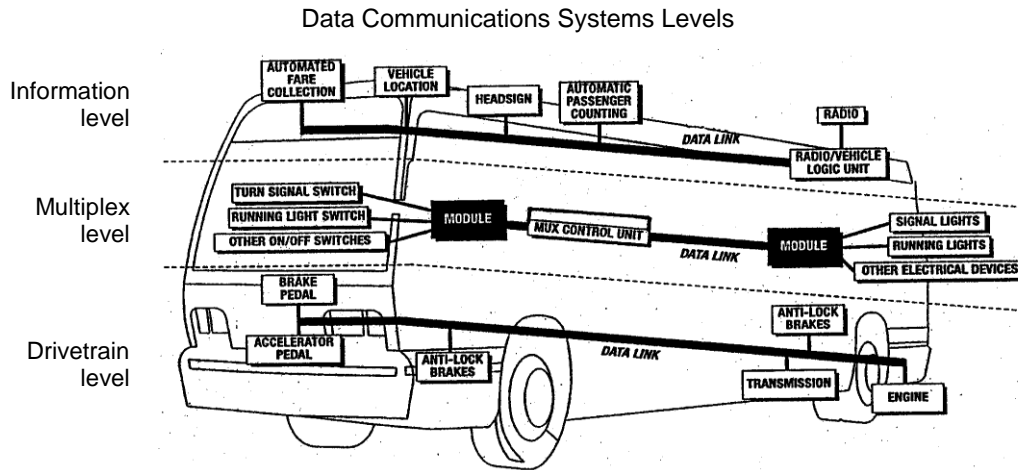

E2.107 Referencing APTA Guideline TS 40.1 Modular Design:

- (a) Design of the electrical, electronic and data communication systems shall be modular so that each electronic device, apparatus panel, or wiring bundle is easily separable from its interconnect by means of connectors.
- (b) Powerplant wiring shall be an independent wiring harness. Replacement of the engine compartment wiring harness(es) shall not require pulling wires through any bulkhead or removing any terminals from the wires.

E2.108 Referencing APTA Guideline TS 41. Environmental and Mounting Requirements:

- (a) The electrical system and its electronic components shall be capable of operating in the area of the vehicle in which they will be installed, as recommended in SAE J1455.
- (b) Electrical and electronic equipment shall not be located in an environment that will reduce the performance or shorten the life of the component or electrical system when operating within the design operating profile. As a recommendation, no vehicle component shall generate, or be affected by, electromagnetic interference or radio frequency interference (EMI/RFI) that can disturb the performance of electrical/electronic equipment as defined in SAE J1113 and UNECE Council Directive 95/54 (R 10).
- (c) The City shall follow recommendations from bus manufacturers and subsystem Suppliers regarding methods to prevent damage from voltage spikes generated from welding, jump starts, shorts, etc.

E2.109 Referencing APTA Guideline TS 41.1 Hardware Mounting:

- (a) The mounting of the hardware shall not be used to provide the sole source ground, and all hardware shall be isolated from potential EMI/RFI, as referenced in SAE J1113.
- (b) All electrical/electronic hardware mounted in the interior of the vehicle shall be inaccessible to passengers and hidden from view unless intended to be viewed. The hardware shall be mounted in such a manner as to protect it from splash or spray and be sealed from exposure to dust.
- (c) All electrical/electronic hardware mounted on the exterior of the vehicle that is not designed to be installed in an exposed environment shall be mounted in a sealed enclosure.
- (d) All electrical/electronic hardware and its mounting shall comply with the shock and vibration requirements of SAE J1455.

E2.110 Referencing APTA Guideline TS 42.1.1 Low-Voltage Batteries (24V):

- (a) Deep Cycle Maintenance -Free Batteries.
 - (i) **The batteries shall be monitored and maintained by a Battery Maintenance System.**
 - (ii) **2-8A8D, AMG, pure virgin lead, minimum of 1800 cranking amp, 1450CCA, reserve capacity of 500 min.**
 - (iii) **Minimum warranty 1 year full replacement. Each battery shall have a purchase date no more than one year from the date of release for shipment to the City.**
- (b) Different Size Terminal Ends.
 - (i) Positive (1/2") and negative (3/8") terminal ends shall be different sizes.

E2.111 Referencing APTA Guideline TS 42.1.2 Battery Cables:

- (a) The battery terminal ends and cable ends shall be color-coded with red for the primary positive, black for negative and another color for any intermediate voltage cables. Positive and negative battery cables shall not cross each other if at all possible, shall be flexible and shall be sufficiently long to reach the batteries with the tray in the extended position without stretching or pulling on any connection and shall not lie directly on top of the batteries. Except as interrupted by the master battery switch, battery and starter wiring shall be continuous cables with connections secured by bolted terminals and shall conform to specification requirements of SAE Standard J1127–Type SGR, SGT, SGX or GXL and SAE Recommended Practice J541, with 2100 strand 4/0 cable or greater.
- (b) Color code each voltage.
- (c) **Unfused/fused cables, (connected to the battery, starter, electric radiator fans, and alternator) must be rigidly independently supported, separated from each other and not bundles with other cables/wires.**

E2.112 Referencing APTA Guideline TS 42.1.3 Jump Start: Jump-Start Connector:

- (a) A jump-start connector, red for 24V and blue for 12V, shall be on the bus side next to the battery disconnect switch. **The connector shall be equipped with a dust cap and adequately protected from moisture, dirt and debris. The connector shall be compatible with the Red “Anderson style” connector (SB350, SB series 350 amp). A grounding stud shall be provided within close proximity to the positive jump start connection complete with a dust boot to adequately protect form moisture and dirt.**

E2.113 Referencing APTA Guideline TS 40.1.4 Battery Compartment:

- (a) The battery compartment shall prevent accumulation of snow, ice and debris on top of the batteries and shall be adequately vented and self-draining. It shall be accessible only from the outside of the vehicle. All components within the battery compartment, and the compartment itself, shall be protected from damage or corrosion from the electrolyte. The inside surface of the battery compartment's access door shall be electrically insulated, as required, to prevent the battery terminals from shorting on the door if the door is damaged in an accident or if a battery comes loose.
- (b) The vehicle shall be equipped with a 12VDC and 24VDC quick disconnect switch(es). The battery compartment door shall conveniently accommodate operation of the 12VDC and 24VDC quick disconnect switch(es).
- (c) The battery quick disconnect access door shall be identified with a decal. The decal size shall not be less than 3.5 × 5 in. (8.89 × 12.7 cm).
- (d) The battery hold-down bracket shall be constructed of a non-metallic material (plastic or fiberglass).
- (e) This access door shall not require any special locking devices to gain access to the switch, and it shall be accessible without removing or lifting the panel. The door shall be flush-fitting and incorporate a spring tensioner or equal to retain the door in a closed position when not in use.

- (f) The batteries shall be securely mounted on a stainless steel or equivalent tray that can accommodate the size and weight of the batteries. The battery tray shall pull out easily and properly support the batteries while they are being serviced. The tray shall allow each battery cell to be easily serviced and filled. A locking device shall retain the battery tray to the stowed position.
- (g) If not located in the engine compartment, the same fire-resistant properties must apply to the battery compartment. No sparking devices should be located within the battery box.

E2.114 Referencing APTA Guideline TS 42.1.5 Auxiliary Electronic Power Supply:

- (a) If required, gel-pack, or any form of sealed (non-venting) batteries used for auxiliary power are allowed to be mounted on the interior of the vehicle if they are contained in an enclosed, non- airtight compartment and accessible only to maintenance personnel. This compartment shall contain a warning label prohibiting the use of lead-acid batteries.

E2.115 Referencing APTA Guideline TS 42.1.6 Master Battery Switch:

- (a) **A single master switch shall be provided near the battery compartment for the disconnecting of all battery positives (12V and 24V), except for safety and other systems as specified. The master battery switch shall be accessible in less than 10 seconds for deactivation and prevent corrosion from fumes and battery acid when the batteries are washed off or are in normal service.**
- (b) Turning the master switch off with the power plant operating shall shut off the engine and shall not damage any component of the electrical system. The master switch shall be capable of carrying and interrupting the total circuit load.

E2.116 Referencing APTA Guideline TS 42.1.7 Low-Voltage Generation and Distribution:

- (a) The low-voltage generating system shall maintain the charge on fully charged batteries, except when the vehicle is at standard idle with a total low voltage generator load exceeding 70 percent of the low voltage generator nameplate rating.
- (b) **The alternator shall be an EMP Power 450 brushless air cooled alternator.**
- (c) Voltage monitoring and over-voltage output protection (recommended at 32V) shall be provided.
- (d) Dedicated power and ground shall be provided as specified by the component or system manufacturer. Cabling to the equipment must be sized to supply the current requirements with no greater than a 5 percent volt drop across the length of the cable.
- (e) Battery Management System:
 - (i) A battery management system shall be installed to regulate the battery charging system; including battery temperature and amperage charging rate. **Must be a 24 Volt Transtec voltage regulator.**

E2.117 Referencing APTA Guideline TS 42.1.8 Circuit Protection:

- (a) All branch circuits, except battery-to-starting motor and battery-to-generator/alternator circuits, shall be protected by current-limiting devices such as circuit breakers, fuses or solid state devices sized to the requirements of the circuit. Electronic circuit protection for the cranking motor shall be provided to prevent engaging of the motor for more than 30 seconds at a time to prevent overheating. The circuit breakers or fuses shall be easily accessible for authorized personnel. Fuses shall be used only where it can be demonstrated that circuit breakers are not practicable. This requirement applies to in-line fuses supplied by either the Contractor or a Supplier. Fuse holders shall be constructed to be rugged and waterproof. All manual reset circuit breakers critical to the operation of the bus shall be mounted in a location convenient to the City mechanic with visible indication of open circuits. The City shall consider the application of automatic reset circuit breakers on a case-by-case basis. The Contractor shall show all in-line fuses in the final harness drawings. Any manually resettable circuit breakers shall provide a visible indication of open circuits. Any manually resettable circuit breakers shall provide a visible indication of open circuits.

- (b) Circuit breakers or fuses shall be sized to a minimum of 15 percent larger than the total circuit load. The current rating for the wire used for each circuit must exceed the size of the circuit protection being used **by a minimum of 25 percent.**

E2.118 Referencing APTA Guideline TS 42.2 Grounds:

- (a) The battery shall be grounded to the vehicle chassis/frame at one location only, as close to the batteries as possible. When using a chassis ground system, the chassis shall be grounded to the frame in multiple locations, evenly distributed throughout the vehicle to eliminate ground loops. No more than three ground ring/spade terminal connections shall be made per ground stud. Electronic equipment requiring an isolated ground to the battery (i.e., electronic ground) shall not be grounded through the chassis. The starter and alternator cables shall be continuous cables and shall not be grounded through the chassis.

E2.119 Referencing APTA Guideline TS 42.3 Low Voltage/Low Current Wiring and Terminals:

- (a) All power and ground wiring shall conform to specification requirements of SAE Recommended Practice J1127, J1128 and J1292. Double insulation shall be maintained as close to the junction box, electrical compartment or terminals as possible. The requirement for double insulation shall be met by wrapping the harness with plastic electrical tape or by sheathing all wires and harnesses with non-conductive, rigid or flexible conduit.
- (b) Wiring shall be grouped, numbered (**with permeate non-fading numbers**) and/or color-coded. Wiring harnesses shall not contain wires of different voltage classes unless all wires within the harness are insulated for the highest voltage present in the harness. Kinking, grounding at multiple points, stretching, and exceeding minimum bend radius shall be prevented.
- (c) **Wiring harness/cables must be support to prevent rubbing/chafing.**
- (d) Strain-relief fittings shall be provided at all points where wiring enters electrical compartments. Grommets or other protective material shall be installed at points where wiring penetrates metal structures outside of electrical enclosures. Wiring supports shall be protective and non-conductive at areas of wire contact and shall not be damaged by heat, water, solvents or chafing.
- (e) To the extent practicable, wiring shall not be located in environmentally exposed locations under the vehicle. Wiring and electrical equipment necessarily located under the vehicle shall be fully insulated from water, environmental elements, heat, corrosion and mechanical damage. Front to rear electrical harnesses should be installed above the window line of the vehicle.
- (f) All wiring harnesses over 5 ft. long and containing at least five wires shall include 10 percent (minimum one wire) excess wires for spares. This requirement for spare wires does not apply to data links and communication cables. Wiring harness length shall allow end terminals to be replaced twice without pulling, stretching or replacing the wire (minimum 2 inches). Terminals shall be crimped to the wiring according to the connector manufacturer's recommendations for techniques and tools. All cable connectors shall be locking type, keyed and sealed, unless enclosed in watertight cabinets or vehicle interior. Pins shall be removable, crimp contact type, of the correct size and rating for the wire being terminated. Unused pin positions shall be sealed with sealing plugs. Adjacent connectors shall either use different inserts or different insert orientations to prevent incorrect connections.
- (g) Terminals shall be crimped, corrosion-resistant and full ring type or interlocking lugs with insulating ferrules. When using pressure type screw terminal strips, only stranded wire shall be used. Insulation clearance shall ensure that wires have a minimum of "visible clearance" and a maximum of two times the conductor diameter or 1/16 inches, whichever is less. When using shielded or coaxial cable, upon stripping of the insulation, the metallic braid shall be free from frayed strands that can penetrate the insulation of the inner wires.
- (h) **Ultra-sonic and T-splices shall not be located in the engine compartment, undercarriage or exposed to the elements.**

- (i) Ultra-sonic and T-splices may be used with **7 AWG** or smaller wire. When a T-splice is used, it shall meet these additional requirements:
 - (i) shall include a mechanical clamp in addition to solder on the splice;
 - (ii) wires shall support no mechanical load in the area of the splice; and
 - (iii) wires shall be supported to prevent flexing.
- (j) All splicing shall be staggered in the harness so that no two splices are positioned in the same location within the harness.
- (k) Wiring located in the engine compartment **shall heat rated for the engine compartment** and be routed away from high-heat sources or shielded and/or insulated from temperatures exceeding the wiring and connector operating requirements.
- (l) The instrument panel and wiring shall be easily accessible for service from the operator's seat or top of the panel. The instrument panel shall be separately removable and replaceable without damaging the instrument panel or gauges. Wiring shall have sufficient length and be routed to permit service without stretching or chafing the wires.
- (m) **Electronic parts list of all connectors, including pins, seals, locks, etc. must be supplied with pilot/lead bus.**

E2.120 Referencing APTA Guideline TS 42.4 Electrical Components:

- (a) All electrical components, including switches, relays, flashers and circuit breakers, shall be heavy-duty designs with either a successful history of application in heavy-duty vehicles or design specifications for an equivalent environment.
- (b) All electric motors shall be heavy-duty brushless type where practical, and have a continuous duty rating of no less than 40,000 hours (except cranking motors, washer pumps and wiper motors). All electric motors shall be easily accessible for servicing.

E2.121 Referencing APTA Guideline TS 42.5 Electrical Compartments:

- (a) All relays, controllers, flashers, circuit breakers and other electrical components shall be mounted in easily accessible electrical compartments. All compartments exposed to the outside environment shall be corrosion-resistant and sealed. The components and their functions in each electrical compartment shall be identified and their location permanently recorded on a drawing attached to the inside of the access panel or door when possible. The drawing shall be protected from oil, grease, fuel and abrasion.
- (b) The front compartment shall be completely serviceable from the operator's seat, vestibule or from the outside. "Rear start and run" controls shall be mounted in an accessible location in the engine compartment and shall be protected from the environment.
- (c) **The PLC shall be initialized from the rear engine compartment when the following conditions are met:**
 - (i) **rear run switch is in the rear run position;**
 - (ii) **start push button held for 5 seconds; and**
 - (iii) **audio/visual warning activated (i.e. back-up lights/amber light flashing).**

E2.122 Referencing APTA Guideline TS 43. General Electronic Requirements:

- (a) If an electronic component has an internal real-time clock, it shall provide its own battery backup to monitor time when battery power is disconnected, and/or it may be updated by a network component. If an electronic component has an hour meter, it shall record accumulated service time without relying on battery backup.
- (b) All electronic component Suppliers shall ensure that their equipment is self-protecting in the event of shorts in the cabling, and also in over-voltage (over 32V DC on a 24V DC nominal voltage rating with a maximum of 50V DC) and reverse polarity conditions. If an electronic component is required to interface with other components, it shall not require external pull-up and/or pull-down resistors. Where this is not possible, the use of a pull-up or pull-down resistor shall be limited as much as possible and easily accessible and labeled.

E2.123 Referencing APTA Guideline TS 43.1 Wiring and Terminals:

- (a) **All terminal connectors shall be a solid pin for use in heavy duty operation manufactured using cold heading process with solid copper alloy wire.** Kinking, grounding at multiple points, stretching and reducing the bend radius below the manufacturer's recommended minimum shall not be permitted.

E2.124 Referencing APTA Guideline TS 43.1.1 Discrete I/O (Inputs/Outputs):

- (a) All wiring to I/O devices, either at the harness level or individual wires, shall be labeled, stamped or fade resistant color-coded in a fashion that allows unique identification at a spacing not exceeding 4 in. Wiring for each I/O device shall be bundled together. If the I/O terminals are the same voltages, then jumpers may be used to connect the common nodes of each I/O terminal.

E2.125 Referencing APTA Guideline TS 43.1.2 Shielding:

- (a) All wiring that requires shielding shall meet the following minimum requirements. A shield shall be generated by connecting to a ground, which is sourced from a power distribution bus bar or chassis. A shield shall be connected at one location only, typically at one end of the cable. However certain standards or special requirements, such as SAE J1939 or RF applications, have separate shielding techniques that also shall be used as applicable.
 - (i) Note: A shield grounded at both end forms a ground loop, which can cause intermittent control or faults.
- (b) When using shielded or coaxial cable, upon stripping of the insulation, the metallic braid shall be free from frayed strands, which can penetrate the insulation of the inner wires. To prevent the introduction of noise, the shield shall not be connected to the common side of a logic circuit.

E2.126 Referencing APTA Guideline TS 43.1.3 Communications:

- (a) The data network cabling shall be selected and installed according to the vendor protocol requirements. Cabling shall be continuous and no splicing shall be permitted. The physical layer of all network communication systems shall not be used for any purpose other than communication between the system components, unless provided for in the network specifications.
- (b) Communications networks that use power line carriers (e.g., data modulated on a 24V-power line) shall meet the most stringent applicable wiring and terminal specifications.

E2.127 Referencing APTA Guideline TS 43.1.4 Radio Systems:

- (a) **Radio antennae and all radio cabling shall be specified by INFODEV Electronic.**
- (b) **Designers International Inc. All installation by the Contractor.**

REFERENCING APTA GUIDELINE TS 44 MULTIPLEXING

E2.128 Referencing APTA Guideline TS 44.1 General:

- (a) The primary purpose of the multiplexing system is control of components necessary to operate the vehicle. This is accomplished by processing information from input devices and controlling output devices through the use of an internal logic program.
- (b) Versatility and future expansion shall be provided for by expandable system architecture. The multiplex system shall be capable of accepting new inputs and outputs through the addition of new modules and/or the utilization of existing spare inputs and outputs. All like components in the multiplex system shall be modular and interchangeable with self-diagnostic capabilities. The modules shall be easily accessible for troubleshooting electrical failures and performing system maintenance. Multiplex input/output modules shall use solid-state devices to provide extended service life and individual circuit protection.
- (c) **All modules shall be repairable at the component level. The programmable IC chips shall not be copy protected and shall be readable by the City.**

- (d) Ten percent of the total number of inputs and outputs, or at least one each for each voltage type utilized (0V, 12V, 24V), at each module location shall be designated as spares.
- (e) **Computers.**
 - (i) **The Contractor must supply six (6) Toughbook computers per bus build/tender, including each extension, to be used for diagnostic and programming functions. The computers must be equipped with the latest version of the Windows operating system, integral pointing devices, the largest capacity hard drive available for the computer and a minimum 64Mb RAM memory.**
 - (ii) **The computers programming software will be held in escrow for programs such as Engine, Transmission, PLC, ABS, Electronic Signs, and all other Electronic equipment included in the vehicle.**
 - (iii) **The computers shall include all peripheral communication hardware, such as PIC's, links and cabled adapters used in downloading and programming of the equipment. Data Link cabled connectors shall be provided 10 cabled connectors per bus build to function with computer equipment and all applicable software provided. Cigarette type plug-in to be provided at lap top diagnostic plug locations for lap top operation.**
 - (iv) **The City of Winnipeg shall have final approval of the hardware and software to be supplied. Computers supplied under contract must be available for testing of all functions and data link connections during pre-delivery inspections.**

E2.129 Referencing APTA Guideline TS 44.2 System Configuration:

- (a) Multiplexing may either be distributed or centralized. A distributed system shall process information on multiple control modules within the network. A centralized system shall process the information on a single control module. Either system shall consist of several modules connected to form a control network.

E2.130 Referencing APTA Guideline TS 44.2.1 I/O Signals:

- (a) **The input/output for the multiplex system may contain four types of electrical signals: discrete, analog, serial data or pulse width modulated (PWM).**
- (b) Discrete signals shall reflect the on/off status of switches, levers, limit switches, lights, etc. Analog signals shall reflect numerical data as represented by a voltage signal (0-12V, 10-24V, etc.) or current signal (4-20 mA). Both types of analog signals shall represent the status of variable devices such as rheostats, potentiometers, temperature probes, etc. Serial data signals shall reflect ASCII or alphanumeric data used in the communication between other on-board components.

REFERENCING APTA GUIDELINE TS 45 DATA COMMUNICATIONS

E2.131 Referencing APTA Guideline TS 45.1 General:

- (a) All data communication networks shall be either in accordance with a nationally recognized interface standard, such as those published by SAE, IEEE or ISO, or shall be published to the City with the following minimum information:
 - (i) Protocol requirements for all timing issues (bit, byte, packet, inter-packet timing, idle line timing, etc.) packet sizes, error checking and transport (bulk transfer of data to/from the device).
 - (ii) Data definition requirements that ensure access to diagnostic information and performance characteristics.
 - (iii) The capability and procedures for uploading new application or configuration data.
 - (iv) Access to revision levels of data, application software and firmware.
 - (v) The capability and procedures for uploading new firmware or application software.
 - (vi) Evidence that applicable data shall be broadcast to the network in an efficient manner such that the overall network integrity is not compromised.

- (b) Any electronic vehicle components used on a network shall be conformance tested to the corresponding network standard.

E2.132 Referencing APTA Guideline TS 45.2 Drivetrain Level:

- (a) Drivetrain components, consisting of the engine, transmission, retarder, anti-lock braking system and all other related components, shall be integrated and communicate fully with respect to vehicle operation with data using SAE Recommended Communications Protocols such as J1939 and/or J1708/J1587 with forward and backward compatibilities or other open protocols. At a minimum, drivetrain components consisting of the engine, transmission, retarder ASR, and anti-lock braking systems shall be powered by a dedicated and isolated ignition supply voltage to ensure data communication among components exists when the vehicle ignition is switched to the "on" position.

E2.133 Referencing APTA Guideline TS 45.2.1 Diagnostics, Fault Detection and Data Access:

- (a) Drivetrain performance, maintenance and diagnostic data, and other electronic messages shall be formatted and transmitted on the communications networks.
- (b) The drivetrain level shall have the ability to record abnormal events in memory and provide diagnostic codes and other information to service personnel. At a minimum, this network level shall provide live/fail status, current hardware serial number, software/data revisions and uninterrupted timing functions.

E2.134 Referencing APTA Guideline TS 45.2.2 Programmability (Software):

- (a) The drivetrain level components shall be programmable by the City with limitations as specified by the sub-system Supplier.

REFERENCING APTA GUIDELINE TS 45.3 MULTIPLEX LEVEL

E2.135 Referencing APTA Guideline TS 45.3.1 Data Access:

- (a) At a minimum, information shall be made available via a communication port on the multiplex system. The location of the communication port shall be easily accessible. A hardware gateway and/or wireless communications system are options if requested by the City. **The communication port(s), including 12 volt cigarette lighter power port, shall be located as specified by the City in four locations:**
 - (i) **Engine start box;**
 - (ii) **Rear of front entrance door below light panel;**
 - (iii) **Behind the driver; and**
 - (iv) **Under front dash.**

E2.136 Referencing APTA Guideline TS 45.3.2 Diagnostics and Fault Detection:

- (a) The multiplex system shall have a proven method of determining its status (system health and input/output status) and detecting either active (online) or inactive (offline) faults through the use of on-board visual/audible indicators.
- (b) In addition to the indicators, the system shall employ an advanced diagnostic and fault detection system, which shall be accessible via either a personal computer or a handheld unit. Either unit shall have the ability to check logic function. The diagnostic data can be incorporated into the information level network or the central data access system.

E2.137 Referencing APTA Guideline TS 45.3.3 Programmability (Software):

- (a) The multiplex system shall have security provisions to protect its software from unwanted changes. This shall be achieved through any or all of the following procedures:
 - (i) password protection;
 - (ii) limited distribution of the configuration software;
 - (iii) limited access to the programming tools required to change the software; and
 - (iv) hardware protection that prevents undesired changes to the software.

- (b) Provisions for programming the multiplex system shall be possible through a PC or laptop. The multiplex system shall have proper revision control to ensure that the hardware and software are identical on each vehicle equipped with the system. Revision control shall be provided by all of the following:
 - (i) hardware component identification where labels are included on all multiplex hardware to identify components;
 - (ii) hardware series identification where all multiplex hardware displays the current hardware serial number and firmware revision employed by the module;
 - (iii) software revision identification where all copies of the software in service displays the most recent revision number; and
 - (iv) a method of determining which version of the software is currently in use in the multiplex system.
- (c) Revision control labels shall be electronic.

E2.138 Referencing APTA Guideline TS 45.4 Electronic Noise Control:

- (a) Electrical and electronic sub-systems and components on all buses shall not emit electromagnetic radiation that will interfere with on-board systems, components or equipment, telephone service, radio or TV reception or violate regulations of the Federal Communications Commission.
- (b) Electrical and electronic sub-systems on the coaches shall not be affected by external sources of RFI/EMI. This includes, but is not limited to, radio and TV transmission, portable electronic devices including computers in the vicinity of or onboard the buses, ac or dc power lines and RFI/EMI emissions from other vehicles.

REFERENCING APTA GUIDELINE TS 46 OPERATOR'S AREA CONTROLS

E2.139 Referencing APTA Guideline TS 46.1 General:

- (a) In general when designing the operator's area, it is recommended that SAE J833, "Human Physical Dimensions," be used.
- (b) Switches and controls shall be divided into basic groups and assigned to specific areas, in conformance with SAE Recommended Practice J680, Revised 1988, "Location and Operation of Instruments and Controls in Motor Truck Cabs," and be essentially within the hand reach envelope described in SAE Recommended Practice J287, "Operator Hand Control Reach."

E2.140 Referencing APTA Guideline TS 46.2 Glare:

- (a) The operator's work area shall be designed to minimize glare to the extent possible. Objects within and adjacent to this area shall be matte black in color wherever possible to reduce the reflection of light onto the windshield. The use of polished metal and light-colored surfaces within and adjacent to the operator's area shall be avoided.

E2.141 Referencing APTA Guideline TS 46.3 Visors/Sun Shades:

- (a) Operator's Windshield and Window Sunscreens.
 - (i) An adjustable roller type sunscreen shall be provided over the operator's windshield and the operator's side window. The sunscreen shall be capable of being lowered to the midpoint of the operator's window. When deployed, the screen shall be secure, stable and shall not rattle, sway or intrude into the operator's field of view due to the motion of the coach or as a result of air movement. Once lowered, the screen shall remain in the lowered position until returned to the stowed position by the operator. Sunscreen shall be shaped to minimize light leakage between the visor and windshield pillars to the extent possible. Sun visor construction and materials shall be strong enough to resist breakage during adjustments. Visors, when deployed, shall be effective in the operator's field of view at angles more than 5 degrees above the horizontal.

E2.142 Referencing APTA Guideline TS 46.4 Operator's Controls:

- (a) Frequently used controls must be in easily accessible locations. These include the door control, kneeling control, windshield wiper/washer controls, ramp, and lift and run switch. Any switches and controls necessary for the safe operation of the bus shall be conveniently located and shall provide for ease of operation. They shall be identifiable by shape, touch and permanent markings. Controls also shall be located so that passengers may not easily tamper with control settings.
- (b) **The rear door override, kneeling and ramp and switches shall be operable from the door control handle.**
- (c) All panel-mounted switches and controls shall be marked with easily read identifiers. Graphic symbols shall conform to SAE Recommended Practice J2402, "Road Vehicles – Symbols For Controls, Indicators, and Tell Tales," where available and applicable. Color of switches and controls shall be dark with contrasting typography or symbols.
- (d) Mechanical switches and controls shall be replaceable, and the wiring at these controls shall be serviceable from a convenient location. Switches, controls and instruments shall be dust- and water-resistant.
- (e) All switches/controls in the operator's controls area shall be mounted in an angled panel steep enough to discourage operators from using it as a personal storage area for items like food, drinks, cell phones, etc.

E2.143 Referencing APTA Guideline TS 46.5 Normal Bus Operation Instrumentation and Controls:

- (a) The following list identifies bus controls used to operate the bus. These controls are either frequently used or critical to the operation of the bus. They shall be located within easy reach of the operator. The operator shall not be required to stand or turn to view or actuate these controls unless specified otherwise.
- (b) Systems or components monitored by onboard diagnostics system shall be displayed in clear view of the operator and provide visual and/or audible indicators. The intensity of indicators shall permit easy determination of on/off status in bright sunlight but shall not cause a distraction or visibility problem at night. All indicators shall be illuminated using backlighting.
- (c) The indicator panel shall be located in Area 1 or Area 5, within easy view of the operator instrument panel. All indicators shall have a method of momentarily testing their operation. The audible alarm shall be tamper-resistant and shall have an outlet level between 80 and 83 dBA when measured at the location of the operator's ear.
- (d) On-board displays visible to the operator shall be limited to indicating the status of those functions described herein that are necessary for the operation of the bus. All other indicators needed for diagnostics and their related interface hardware shall be concealed and protected from unauthorized access. Table 6 represents instruments and alarms. The intent of the overall physical layout of the indicators shall be in a logical grouping of systems and severity nature of the fault.
- (e) Consideration shall be provided for future additions of spare indicators as the capability of onboard diagnostic systems improves. Blank spaces shall contain LEDs.
- (f) Table 6 (Transit Coach) Instruments and Alarms.

TABLE 6 (Transit Coach)
Transit Bus Instruments and Alarms

Device	Description	Location	Function	Visual/ Audible
Master run switch	Rotary, four-position detent	Side console	Master control for bus, off, day run, night run and clearance ID lights	
Engine start, front	Approved momentary switch	Side console	Activates engine starter motor	

TABLE 6 (Transit Coach)
Transit Bus Instruments and Alarms

Device	Description	Location	Function	Visual/ Audible
Engine start, rear	Approved momentary switch (SAE IP67 rated)	Engine compartment	Activates engine starter motor	
Engine run, rear	Three-position toggle switch	Engine compartment	Permits running engine from rear start, normal front run position and off	Amber light
Drive selector	Touch panel switch	Right front dash.	Provides selection of propulsion: forward, reverse and neutral	Gear selection
HVAC	Switch or switches to control HVAC	Side console	Permits selection of passenger ventilation: Auto, off, and vent.	
Driver's ventilation	Rotary, three-position detent	Side console or dash left wing	Permits supplemental ventilation: fan off, low or high	
Defroster fan	Rotary, three-position detent	Side console or dash left wing	Permits defroster: fan off, low, medium or high	
Defroster temperature	Variable position	Side console or dash left wing	Adjusts defroster water flow and temperature	
Windshield wiper	Variable rotary position operating each wiper separately	Dash left wing	Variable speed control of left and right windshield wipers	
Windshield washer	Push button	Dash left wing	Activates windshield washers	
Dash panel lights	Rotary rheostat or stepping switch	Side console or dash left wing	Provides adjustment for light intensity in night run position	
Interior lights	Two-position switch	Side console	Selects mode of passenger compartment lighting: off, on, normal	
Fast idle	Two-position switch	Side console	Selects high idle speed of engine	
Front door ramp	Three-position momentary switch with protective guard, spring loaded for deploy.	Side console – within hand reach of door control handle	Permits deploy and stow of front ramp with interlock applied.	Red light

TABLE 6 (Transit Coach)
Transit Bus Instruments and Alarms

Device	Description	Location	Function	Visual/ Audible
Front kneel	Three-position momentary switch spring loaded for lower and raise.	Side console – within hand reach of door control handle	Permits kneeling activation and raise and normal at front door remote location	Amber or red dash indicator; exterior alarm and amber light
Video system event switch	Momentary on/off momentary switch	Side console	Triggers event equipment, triggers event light on dash	Red light
Left remote mirror	Four-position toggle type	Side console	Permits two-axis adjustment of left exterior mirror	
Right remote mirror	Four-position toggle type	Side console	Permits two-axis adjustment of right exterior mirror	
Mirror heater	Activated with front defroster.	Defroster switch	Permits heating of outside mirrors when required	
Passenger door control	Five-position handle type detent	Side console, forward	Permits open/close control of front and rear passenger doors	
Rear door override	Two-position switch in approved location	Side console, forward	Allows driver to override activation of rear door passenger tape switches	
Engine shutdown override	Momentary switch with operation protection	Side console	Permits driver to override auto engine shutdown	
Hazard flashers	Two-position switch with 50mm actuator lever	Side console	Activates emergency flashers	Two green lights
Fire suppression	Red push button with safety pin lock.	Side console or left overhead.	Permits driver to override and manually discharge fire suppression system	Red light
Destination sign interface	Destination sign interface panel	In approved location	Facilitates driver interaction with destination sign system, manual entry	LCD display
Turn signals	Momentary push button (two required) raised from other switches	Left foot panel, Mounted with SS ¼" bolts.	Activates left and right turn signals	Two green lights and optional audible indicator
PA manual	Momentary push button	Left foot panel. Mounted with SS ¼" bolts.	Permits driver to manually activate public address microphone	

TABLE 6 (Transit Coach)
Transit Bus Instruments and Alarms

Device	Description	Location	Function	Visual/ Audible
Low-profile microphone	Atlas Sound gooseneck assembly	Left front upper corner of the operator's compartment.	Permits driver to make announcements with both hands on the wheel and focusing on road conditions	
High beam	Detented push button	Left foot floor. Mounted with SS ¼" bolts.	Permits driver to toggle between low and high beam	Blue light
Parking brake	Pneumatic PPV	Side console	Permits driver to apply and release parking brake. Yellow to push to release.	Red light
Park brake release	Pneumatic PPV	Side console	Permits driver to push and hold to release brakes	
Remote engine speed	Rotary rheostat	Engine compartment	Permits technician to raise and lower engine RPM from engine compartment	
Master door/ interlock	Toggle, with protective guard.	Out of operator's seated reach	Permits driver override to disable door and brake/throttle interlock	Red light
Warning interlocks deactivated	Red indicator light	Dash panel center	Illuminates to warn driver that interlocks have been deactivated	Red light and alarm
Retarder disable	Toggle Switch	Within reach of operator	Permits driver override to disable brake retardation/regeneration	Red light
Auxiliary power	12 V power receptacle	Approved location	Property to specify what function to supply	
Speedometer	Speedometer, odometer, and diagnostic capability, 10 kilometer increments, no trip meter	Dash center panel	Visual indication of speed and distance traveled, accumulated vehicle mileage, fault condition display	Visual
Air pressure gauge	Primary and secondary, 5 psi increments	Dash center panel	Visual indication of primary and secondary air systems	Red light and buzzer
Fire detection	Coach operator display	Property specific or dash center	Indication of fire detection activation by zone/location	Buzzer and red light
Door obstruction	Sensing of door obstruction	Dash center	Indication of rear door sensitive edge activation	Red light and buzzer
Low system air pressure	Sensing low primary and secondary air tank pressure	Dash center	Indication of low air system pressure	Buzzer and red light

TABLE 6 (Transit Coach)
Transit Bus Instruments and Alarms

Device	Description	Location	Function	Visual/ Audible
Engine coolant indicator	Low coolant indicator may be supplied as audible alert and visual and/or text message	Within driver's sight	Detects low coolant condition	Amber light
Cabin Low Coolant	For dual systems. Low coolant indicator may be supplied as audible alert and visual and/or text message.	Within driver's sight	Detects low coolant condition	Amber light.
Hot engine indicator	Coolant temperature indicator may be supplied as audible alert and visual and/or text message	Within driver's sight	Detects hot engine condition and initiates time delay shutdown	Red light
Low engine oil pressure indicator	Engine oil pressure indicator may be supplied as audible alert and visual and/or text message	Within driver's sight	Detects low engine oil pressure condition and initiates time-delayed shutdown	Red light
ABS indicator	Detects system status	Dash center	Displays system failure	Amber light
ABS blink code	Toggle switch	Inside front sign above operator	Retrieve ABS code	
Charging system indicator (12/24 V)	Detect charging system status	Dash center	Detects no charge condition and optionally detects battery high, low, imbalance, no charge condition	Red light flashing or solid based on condition
Fuel tank level	Indicator light	Dash center	Indication of fuel tank level/pressure, at less than 55 litres useable	Yellow
DEF gauge	Level Indicator	Center dash	Displays level of DEF tank and indicates with warning light when low	Red light
Regeneration	Multi-toggle switch	Inside front sign above operator	Initialize, inhibit, normal regeneration	

TABLE 6 (Transit Coach)
Transit Bus Instruments and Alarms

Device	Description	Location	Function	Visual/ Audible
Auxiliary Heater	Toggle switch, Run, off, override.	Overhead left Out of operator's reach	Inhibit auxiliary heater operation	
Stop Request	Stop Request	Stop Request	Passenger stop request	Red, 2cm
Turntable	Detects status	Dash center	Warning indication for hinge locking	Audible and amber warning and red light if locked
Turntable	Interlock momentary switch	Side console	Momentarily release interlock brakes due to over angled condition	

1. Indicate area by drawing. Break up switch control from indicator lights.

E2.144 Referencing APTA Guideline TS 46.6 Operator Foot Controls:

- (a) Accelerator and brake pedals shall be designed for ankle motion. Foot surfaces of the pedals shall be faced with wear-resistant, nonskid, replaceable material.

E2.145 Referencing APTA Guideline TS 46.6.1 Pedal Angle:

- (a) The vertical angle of the accelerator and brake pedals shall be determined from a horizontal plane regardless of the slope of the cab floor. The accelerator and brake pedals shall be positioned at an angle of 37 to 50 degrees at the point of initiation of contact and extend downward to an angle of 10 to 18 degrees at full throttle.
- (b) The location of the brake and accelerator pedals shall be determined by the manufacturer, based on space needs, visibility, lower edge of windshield, and vertical H-point.

E2.146 Referencing APTA Guideline TS 46.6.2 Pedal Dimensions and Position:

- (a) The floor-mounted accelerator pedal shall be 10 to 12 in. long and 3 to 4 in. wide. Clearance around the pedal must allow for no interference precluding operation.
- (b) 1 to 2 in. Between Brake and Accelerator Pedals.
 - (i) The accelerator and brake pedals shall be positioned such that the spacing between them, measured at the heel of the pedals, is between 1 and 2 in. Both pedals should be located approximately on the same plane coincident to the surface of the pedals.

E2.147 Referencing APTA Guideline TS 46.7 Brake and Accelerator Pedals:

- (a) Brake Pedal:
 - (i) Non-adjustable brake pedal.

E2.148 Referencing APTA Guideline TS 46.8 Operator Foot Switches:

- (a) Floor-Mounted Foot Control Platform:
 - (i) The angle of the turn signal platform shall be determined from a horizontal plane, regardless of the slope of the cab floor. The turn signal platform shall be angled at a minimum of 10 degrees and a maximum of 37 degrees. It shall be located no closer to the seat front than the heel point of the accelerator pedal. **Must be mounted using 304 stainless steel bolts.**
- (b) Turn Signal Controls:
 - (i) Turn signal controls shall be floor-mounted, foot-controlled, water-resistant, heavy-duty, momentary contact switches. **Must be mounted using 304 stainless steel bolts.**

- (c) Foot Switch Control:
 - (i) The control switches for the turn signals shall be mounted on an inclined, floor-mounted stainless steel enclosure or metal plate mounted to an incline integrated into the operator's platform, located to the left of the steering column. The location and design of this enclosure shall be such that foot room for the operator is not impeded. The inclined mounting surface shall be skid-resistant. All other signals, including high beam and public address system shall be in approved location. **Must be mounted using 304 stainless steel bolts.**
- (d) The foot switches shall be UL-listed, heavy-duty type, of a rugged, corrosion-resistant metal construction. The foot switches for the directional and PA shall be momentary type, while high beam shall be latching type. The spacing of the switches shall be such that inadvertent simultaneous deflection of switches is prevented. **Must be mounted using 304 stainless steel bolts.**

E2.149 Referencing APTA Guideline TS 47.1 Coat Hanger:

- (a) Suitable hangers (2) shall be installed in a convenient, approved location for the operator's coat.

E2.150 Referencing APTA Guideline TS 47.2 Drink Holder:

- (a) A device, on forward side console, shall be provided to securely hold the operator's drink container, which may vary widely in diameter. It must be mounted within easy reach of the operator and must have sufficient vertical clearance for easy removal of the container. When the container is in the device, the operator's view of the road must not be obstructed, and leakage from the container must not fall on any switches, gauges or controls.

E2.151 Referencing APTA Guideline TS 47.3 Storage Box:

- (a) No storage box required.

E2.152 Referencing APTA Guideline TS 48.1 Windshield Wipers:

- (a) The bus shall be equipped with a windshield wiper for each half of the windshield. At 100 km/h, no more than 10 percent of the wiped area shall be lost due to windshield wiper lift. For two-piece windshields, both wipers shall park along the center edges of the windshield glass. For single-piece windshields, wipers shall park along the bottom edge of the windshield. Windshield wiper motors and mechanisms shall be easily accessible for repairs or service. The fastener that secures the wiper arm to the drive mechanism shall be corrosion-resistant.
- (b) **Dual Control, Electric two-speed intermittent wiper.**
- (c) Intermittent Wiper with Variable Control:
 - (i) A variable-speed feature shall be provided to allow adjustment of wiper speed for each side of the windshield between approximately five (5) and twenty-five (25) cycles per minute.

E2.153 Referencing APTA Guideline TS 48.2 Windshield Washers:

- (a) Windshield washer shall be electric. The windshield washer system, when used with the wipers, shall deposit washing fluid evenly and completely wet the entire wiped area.
- (b) **The windshield washer system shall have a minimum 5-gallon reservoir, located for easy refilling from outside of the bus. Reservoir pumps, lines and fittings shall be corrosion-resistant and must include a means to determine fluid level.**

E2.154 Referencing APTA Guideline TS 49. Operator's Seat:

- (a) **The operator seat shall be a USSC Q90 model.**

E2.155 Referencing APTA Guideline TS 49.1 Dimensions:

- (a) **The operator's seat shall be comfortable and adjustable so that people ranging in size from a 95th-percentile male to a 5th-percentile female may operate the bus.**

- E2.156 Referencing APTA Guideline TS 49.1.1 Seat Pan Cushion Length:
- (a) Measurement shall be from the front edge of the seat pan to the rear at its intersection with the seat back. The adjustment of the seat pan length shall be no less than 16.5 inches at its minimum length and no more than 20.5 inches at its maximum length.
- E2.157 Referencing APTA Guideline SP 12.1.1 Seat Pan Cushion Height:
- (a) Measurement shall be from the cab floor to the top of the level seat at its center midpoint. The seat shall adjust in height from a minimum of 14 in., with a minimum 6 in. vertical range of adjustment.
- E2.158 Referencing APTA Guideline TS 49.1.2 Seat Pan Cushion Slope:
- (a) Measurement is the slope of the plane created by connecting the two high points of the seat, one at the rear of the seat at its intersection with the seat back and the other at the front of the seat just before it waterfalls downward at the edge. The slope can be measured using an inclinometer and shall be stated in degrees of incline relative to the horizontal plane (0 degrees). The seat pan shall adjust in its slope from no less than plus 12 degrees (rearward "bucket seat" incline), to no less than minus 5 degrees (forward slope).
- E2.159 Referencing APTA Guideline TS 49.1.4 Seat Pan Cushion:
- (a) **The seat pan cushion shall be a quick release style.** The seat pan cushion shall be 17 to 21 in. across at the front edge of the seat cushion and 20 to 23 inches across at the side bolsters.
- E2.160 Referencing APTA Guideline TS 49.1.5 Seat Suspension:
- (a) **The operator's seat shall be appropriately dampened to support a minimum weight of 600 lbs. The suspension shall be capable of dampening adjustment in both directions.**
 - (b) Rubber snubbers shall be provided to prevent metal-to-metal contact.
- E2.161 Referencing APTA Guideline TS 49.1.6 Seat Back:
- (a) Width:
 - (i) Measurement is the distance between the outermost points of the front of the seat back, at or near its midpoint in height. The seat back width shall be no less than 19 in. Seat back will include dual recliner gears on both sides of the seat.
 - (b) Height:
 - (i) Standard height seat back.
- E2.162 Referencing APTA Guideline TS 49.1.7 Headrests:
- (a) Must have an adjustable headrest.
- E2.163 Referencing APTA Guideline TS 49.1.8 Seat Back Lumbar Support:
- (a) Measurement is from the bottom of the seat back at its intersection with the seat pan to the top of the lumbar cushioning. The seat back shall provide adjustable depth lumbar back support with three individual operating lumbar cells within a minimum range of 7 to 11 in.
- E2.164 Referencing APTA Guideline TS 49.1.9 Seat Back Angle Adjustment:
- (a) The seat back angle shall be measured relative to a level seat pan, where 90 degrees is the upright position and 90 degrees-plus represents the amount of recline.
 - (b) The seat back shall adjust in angle from a minimum of no more than 90 degrees (upright) to at least 105 degrees (reclined), with infinite adjustment in between.

E2.165 Referencing APTA Guideline TS 49.2 Seat Belt:

- (a) The belt assembly should be an auto-locking retractor (ALR). All seat belts should be stored in automatic retractors. The belts shall be mounted to the seat frame so that the operator may adjust the seat without resetting the seat belt.
- (b) The seat and seat belt assemblies as installed in the bus shall withstand static horizontal forces as required in FMVSS 207 and 210.
- (c) Lap seat belt only with retractor on left side.
- (d) Lap Belt Length:
 - (i) The lap belt assembly shall be a minimum of 72 in. in length.

E2.166 Referencing APTA Guideline TS 49.4 Seat Control Locations:

- (a) While seated, the operator shall be able to make seat adjustments by hand without complexity, excessive effort or being pinched. Adjustment mechanisms shall hold the adjustments and shall not be subject to inadvertent changes.

E2.167 Referencing APTA Guideline TS 49.5 Seat Structure and Materials:

- (a) Cushions:
 - (i) Cushions shall be fully padded with at least 3 inches of materials in the seating areas at the bottom and back.
- (b) Cushion Materials:
 - (i) Foam and fabric, with vinyl boxing, that meets FTA Docket 90A.

E2.168 Referencing APTA Guideline TS 49.6 Pedestal:

- (a) Powder-coated steel.

E2.169 Referencing APTA Guideline TS 49.7 Seat Option:

- (a) Fabric options – subject to City approval.

E2.170 Referencing APTA Guideline TS 49.8.1 Exterior Mirrors:

- (a) The bus shall be equipped with a corrosion-resistant, outside rear view mirrors mounted with stable supports to minimize vibration. Mirrors shall be firmly attached to the bus to minimize vibration and to prevent loss of adjustment with a breakaway mounting system. Mirrors shall permit the operator to view the roadway along the sides of the bus, including the rear wheels. Mirrors should be positioned to prevent blind spots.
- (b) Mirrors shall retract or fold sufficiently to allow bus washing operations but avoid contact with windshield.
- (c) **Control wires, heating wires and weather-proof connectors located externally for ease of replacement.**
- (d) **Spring loaded mirror heads auto return.**
- (e) Flat Mirror – Street Side:
 - (i) **The bus shall be equipped Lucerix mirror with a left outside mirror, with not less than a 9.75" x 7" flat reflective surface, and with not less than a 3.5" x 6" convex reflective surface. The mirrors shall be located so as to provide the operator a view to the rear along the left side of the bus and shall be adjustable both in the horizontal and vertical directions to view the rearward scene. The mirror shall be positioned so that the operator's line of sight is not obstructed.**
- (f) Convex Mirror – Curb Side:
 - (i) **The bus shall be equipped Lucerix mirror with a right outside mirror, with not less than a 9.5" x 10" convex reflective surface. The mirrors shall be located so as to provide the operator a view to the rear along the right side of the bus and shall be adjustable both in the horizontal and vertical directions to view**

the rearward scene. The mirror shall be positioned so that the operator's line of sight is not obstructed. The mirror shall be mounted so that its lower edge is no less than 76 in. above the street surface.

- (g) Remote Adjustment of Curb and Street Side Mirror.
- (h) The operator shall be able to adjust the curb and street side mirror remotely while seated in the driving position. The control for remote positioning of the mirror shall be a single switch or device.
- (i) Heated Curb Side Mirrors:
 - (i) The curb-side mirrors shall have heater that energize whenever the operator's heater and/or defroster is activated.
- (j) Heated Street Side Mirrors:
 - (i) The street-side mirror shall have heater that energize whenever the operator's heater and/or defroster is activated.

E2.171 Referencing APTA Guideline TS 47.7.2 Interior Mirrors:

- (a) Mirrors shall be provided for the operator to observe passengers throughout the bus without leaving the seat and without shoulder movement. The operator shall be able to observe passengers in the front/entrance and rear/exit areas, anywhere in the aisle, and in the rear seats.

E2.172 Referencing APTA Guideline TS 50 Windows General:

- (a) A minimum of 10,000 square inches of window area, including operator and door windows, shall be required on each side of the standard configuration bus.

E2.173 Referencing APTA Guideline TS 51. Windshield:

- (a) The windshield shall permit an operator's field of view as referenced in SAE Recommended Practice J1050. The vertically upward view shall be a minimum of 14 degrees, measured above the horizontal and excluding any shaded band. The vertically downward view shall permit detection of an object 3½ ft. high no more than 2 ft. in front of the bus. The horizontal view shall be a minimum of 90 degrees above the line of sight. Any binocular obscuration due to a center divider may be ignored when determining the 90-degree requirement, provided that the divider does not exceed a 3-degree angle in the operator's field of view. Windshield pillars shall not exceed 10 degrees of binocular obscuration. The windshield shall be designed and installed to minimize external glare as well as reflections from inside the bus.
- (b) The windshield shall be easily replaceable by removing zip-locks from the windshield retaining moldings. Bonded-in-place windshields shall not be used. Winglets may be bonded.

E2.174 Referencing APTA Guideline TS 51.1 Windshield Glazing:

- (a) The windshield glazing material shall have a ¼ in. nominal thickness laminated safety glass conforming to the requirements of ANSI Z26.1 Test Grouping 1A and the Recommended Practices defined in SAE J673.
- (b) Shaded Band:
 - (i) The upper portion of the windshield above the operator's field of view shall have a dark, shaded band with a minimum luminous transmittance of 5 percent when tested in accordance to ASTM D-1003.

E2.175 Referencing APTA Guideline TS 52. Operator's Side Window:

- (a) **The operator's side window shall be a fore and aft sliding type, requiring only the rear half of sash to latch upon closing. The front sash shall open sufficiently to permit the seated operator to easily adjust the street-side outside rear view mirror and shall have an interior handle only. When in an open position, the window shall not rattle or close during braking. This window section shall slide in tracks or channels designed to last the service life of the bus. The operator's side window**

shall not be bonded in place and shall be easily replaceable. The glazing material shall have a single-density tint.

- (b) The operator's side window shall include a "Rapid Replacement Glazing System" that permits the removal and installation of each piece of glass in three (3) minutes or less. Glazing materials shall be one quarter inch or six millimeter (1/4" or 6mm) nominal thickness laminated safety glass strictly conforming to applicable sections of FMVSS 205 and ANSI Z26. 1 – 1997, Test Grouping 2 and the Recommended Practices defined in SAE J673. The maximum permissible light transmittance of the fore and aft sliding sections shall be 75% (Green) and the maximum permissible solar energy transmittance shall be 68% as measured by ASTM-424.
- (c) The operator's view, perpendicular through operator's side window glazing, should extend a minimum of 33 in. (840 mm) to the rear of the heel point on the accelerator, and in any case must accommodate a 95th percentile male operator. The view through the glazing at the front of the assembly should begin not more than 26 in. (560 mm) above the operator's floor to ensure visibility of an under-mounted convex mirror. Operator's window construction shall maximize ability for full opening of the window.
- (d) The operator's side window glazing material shall have a ¼ in. nominal thickness laminated safety glass conforming with the requirements of ANSI Z26.1-1996 Test Grouping 2 and the Recommended Practices defined in SAE J673.
- (e) The design shall prevent sections from freezing closed in the winter.
- (f) Standard Operator's Side Window, Traditional Frame:
 - (i) full slider
 - (ii) non-egress
- (g) Quick Change Operator's Side Window:
 - (i) **Glazing in the window assembly shall be replaced without removing the window from its installed position on the bus or manipulation of the rubber molding surrounding the glazing. The glazing shall be held in place mechanically by a formed metal extruded ring constructed to last the life of the vehicle.**

E2.176 Referencing APTA Guideline TS 53.1 Side Windows Configuration:

- (a) Side windows shall not be bonded in place, but shall be easily replaceable without disturbing adjacent windows and shall be mounted so that flexing or vibration from engine operation or normal road excitation is not apparent. All aluminum and steel material will be treated to prevent corrosion.
- (b) Design:
 - (i) **Side windows shall employ a "Rapid-Replacement Glazing System" that permits the replacement of window glazing in three (3) minutes or less without disturbing adjacent windows. All side windows shall be fixed in position using an internal clamp-ring, except as necessary to meet the emergency escape requirements. All side windows except windows in passenger doors and those smaller than 500 square inches, shall be tip-in sash transom type, flat-glazed with the sash glazing comprising between 25% and 35% of the total window area. The destination sign window shall be a clear fixed over glazed fixed design. The transom window panels shall open inward and shall be equipped with latches and gas cylinders to ensure smooth long-term operation with replaceable mounting blocks that secure the window in a fully open and fully closed position. The tip-in section shall employ a positive engagement mechanism that holds the sash in place when closed and minimizes sash rattle and air and water leakage. The bottom glazing section shall not open except as required for emergency egress. Side windows shall be mounted in the bus structure so that flexing or vibration from engine operation or normal road excitation is minimized.**

- (ii) **Emergency escape windows shall be full egress design and open for emergency escape by means of a durable, heavy-duty cast aluminum handle assembly located on one side of the window and below the window centerline, a metal plate with operating instructions clearly marked and imprinted is to be securely installed adjacent to or on each emergency egress window assembly. The window construction shall be designed using a "Water Management" system that incorporates a visible indirect water drainage system to the exterior of the window and will prevent the entrance or backup of water into the bus interior or sidewall. Drains of sufficient size shall be used at the bottom of each sash that allows drainage of interior condensation to the exterior of the bus. The window manufacturer shall perform a water test that assures the "Water Management System" is functioning properly and is equal to or greater than the following parameters: 12 gallons of water/minute @ 40 psi with multiple strategically placed nozzles for duration of 10 minutes.**

E2.177 Referencing APTA Guideline TS 53.2 Emergency Exit (Egress) Configuration:

- (a) Minimum Egress:
 - (i) All side windows shall be fixed in position, except as necessary to meet the emergency escape requirements.
- (b) Standard Passenger Side Window Configurations:
 - (i) Traditional frame;
 - (ii) 3/4 fixed with inward-opening transom panels; and
 - (iii) Quick Change Passenger Side Windows.
- (c) Glazing in the window assembly shall be replaced without removing the window from its installed position on the bus or manipulation of the rubber molding surrounding the glazing. The glazing shall be held in place mechanically by a formed metal extruded ring constructed to last the life of the vehicle.

E2.178 Referencing APTA Guideline TS 53.3 Fixed Side Window Configuration:

- (a) Operable Windows with Inward-Opening Transom Panels (Fixed Bottom, Tip-In Top).
 - (i) Each operable side window shall incorporate an upper transom portion. The transom shall be between 25 and 35 percent of the total window area. The lower portion of the window shall be fixed. The transom portion shall be hinged along the lower edge and open inward. **Rear windows on both curb and street side shall be fixed tip in.**
- (b) Quick Change Passenger Side Windows:
 - (i) Glazing in the window assembly shall be replaced without removing the window from its installed position on the bus or manipulation of the rubber molding surrounding the glazing. The glazing shall be held in place mechanically by a formed metal extruded ring constructed to last the life of the vehicle.
- (c) **First passenger side window on Street side shall be full fix emergency egress. First passenger window on curb side shall be full fixed. Both windows with be grey tint.**

E2.179 Referencing APTA Guideline TS 53.4 Materials:

- (a) Seals:
 - (i) **The window seal rubber and/or sash frame mounting rubber must be designed using UV stable material made from EPDM closed cell foam to prevent shrinkage and deterioration as well as water leakage. The window primary glazing spline shall be designed as a one-piece rubber extrusion and installed to prevent passengers from readily removing the rubber or glazing. The rubber spline shall be designed to retain the glazing in place with or without the use of window guards. The window bus structure exterior seal shall be an EPDM closed cell foam to ensure maximum seal capacity.**

(b) Frames:

- (i) Window assemblies shall be constructed using 6063-T4 and 6063- T6 aluminum as required for high strength components or suitable composite materials; all materials must be chemically compatible with the window frame and the bus body. Unless otherwise specified aluminum materials used to construct window frames shall be hard anodized per Aluminum Association AA-C22-A21 with hard coat additive. All fasteners and brackets required in the assembly of the window frame shall be stainless steel. Whenever possible, window elements not designed for disassembly shall be bonded together to reduce the potential for vandalism and enhance durability. Such bonding must be stronger than the fasteners it replaces.**

(c) Glazing:

- (i) Glazing materials shall be one quarter inch or six millimeter (1/4" or 6mm) nominal thickness laminated safety glass strictly conforming to applicable sections of FMVSS 205 and ANSI Z26. 1 – 1997. Glazing color shall be consistent from window to window. The maximum permissible light transmittance (or luminous transmittance) shall be 44% (Gray)and the maximum permissible solar energy transmittance shall be 51%as measured by ASTM-424, except for the upper destination sign glazing, which shall be clear. Glazing shall be removable from the window assembly without removing the window from its installed position on the bus.**

(d) Window Guards/Graffiti Protection:

- (i) All side window assemblies shall be designed to accommodate all available graffiti protection options.**

(e) DOT and Manufacturer Identification:

- (i) Each glazing component and or window guard shall have the manufactures Department of Transportation (DOT) registered identification "bug" permanently applied according to the DOT requirement, the "bug" shall include the date (month and year) of manufacture applied in the same location.**

(f) Laminated Glazing Panels:

- (i) Side windows glazing material shall have a minimum of 6 mm nominal thickness laminated safety glass. The material shall conform to applicable requirements of ANSI Z26.1-1996 and the Recommended Practices defined in SAE J673.**

- (g) Windows on the bus sides and in the rear door shall be tinted gray. The maximum solar energy transmittance shall be 44 percent, as measured by ASTM E-424. Luminous transmittance shall be measured by ASTM D-1003.**

E2.180 Referencing APTA Guideline TS 51.5 Rear Window:

- (a) No requirement for rear window.**

HEATING, VENTILATING AND AIR CONDITIONING:

E2.181 Referencing APTA Guideline TS 54. Capacity and Performance:

- (a) The HVAC climate control system shall be capable of controlling the temperature and maintaining the humidity levels of the interior of the bus as defined in the following paragraphs.**
- (b) With the bus running at the design operating profile with corresponding door opening cycle, and carrying a number of passengers equal to 150 percent of the seated load, the HVAC system shall control the average passenger compartment temperature within a range between 65 and 75 °F, while maintaining the relative humidity to a value of 50 percent or less. The system shall maintain these conditions while subjected to any outside ambient**

temperatures within a range of 10 to 95 °F and at any ambient relative humidity levels between 5 and 50 percent.

- (c) When the bus is operated in outside ambient temperatures of 95 to 115 °F, the interior temperature of the bus must maintain 75° F but shall be permitted to rise 0.5° for each degree of exterior temperature in excess of 95 °F.
- (d) When bus is operated in outside ambient temperatures in the range of -35 to 10 °F, the interior temperature of the bus shall not fall below 65°F while the bus is running on the design operating profile.
- (e) System capacity testing, stabilization and profile, shall be conducted in accordance to the APTA's "Recommended Instrumentation and Performance Testing for Transit Bus Air Conditioning System."
- (f) **Upper and lower deck must be controlled as separate temperature zones with independent temperature sensors located 17" above floor, under a passenger seat, or as agreed with the City. Care must be taken to avoid placement of sensing devices in the immediate path of an air duct outlet. In general, the locations are intended to accurately represent the interior passenger area.**
- (g) Additional testing shall be performed as necessary to ensure compliance to performance requirements stated herein.
- (h) Roof Mounted HVAC Unit:
 - (i) The HVAC shall be a **Thermo-King** roof-mounted unit with an engine driven reciprocating A/C compressor set to **cycling clutch**. The compressor shall be belt driven with an automatic tensioner.
- (i) Auxiliary Heating Unit:
 - (i) The auxiliary heating unit shall be a Pro Heat X30. The auxiliary heater plumbing shall prioritize pre-heat to the engine, to maintain optimal operating temperature, and then supplement the bus heating system. **The J1939 diagnostic connector shall be utilized.**
- (j) A/C Connection:
 - (i) Accessibility and serviceability of preventative maintenance components shall be provided, minimizing the maintenance personnel needed to work on the roof of the bus.
- (k) Capacity and Performance Requirements:
 - (i) The air-conditioning portion of the HVAC system shall be capable of reducing the passenger compartment temperature from 110 to 90 °F in less than 20 minutes after engine start-up. Engine temperature shall be within the normal operating range at the time of start-up of the cool-down test, and the engine speed shall be limited to fast idle, which may be activated by an operator-controlled device.
 - (ii) During the cool-down period, the refrigerant pressure shall not exceed safe high-side pressures, and the condenser discharge air temperature, measured 6 in. from the surface of the coil, shall be less than 45 °F above the condenser inlet air temperature. The appropriate solar load as recommended in the APTA "Recommended Instrumentation and Performance Testing for Transit Bus Air Conditioning System," representing 4 p.m. on August 21, shall be used. There shall be no passengers on board, and the doors and windows shall be closed.
- (l) Colder Ambient Conditions:
 - (i) The pull-up requirements for the heating system shall be in accordance with Section 9 of APTA's "Recommended Instrumentation and Performance Testing for Transit Bus Air Conditioning." With ambient temperature at -20 °F, and vehicle cold soaked at that temperature, the bus heating system shall warm the interior passenger compartment to an average temperature of 70 °F ±2 °F within 70 minutes.
- (m) R134A refrigerant:
 - (i) The air conditioning system shall meet these performance requirements using R134A.

E2.182 Referencing APTA Guideline TS 56.1 Air Flow Passenger Area:

- (a) The cooling mode of the interior climate control system shall introduce air into the bus at or near the ceiling height at a minimum rate of 25 cubic ft per minute (cfm) per passenger based on the standard configuration bus carrying a number of passengers equal to 150 percent of the seated load. Airflow shall be evenly distributed throughout the bus, with air velocity not exceeding 100 ft per minute on any passenger. The ventilating mode shall provide air at a minimum flow rate of 20 cfm per passenger.
- (b) Airflow may be reduced to 15 cfm per passenger (150 percent of seated load) when operating in the heating mode. The fans shall not activate until the heating element has warmed sufficiently to ensure at least 70 °F air outlet temperature. The heating air outlet temperature shall not exceed 120 °F under any normal operating conditions.
- (c) The climate control blower motors and fan shall be designed such that their operation complies with the interior noise level requirements.

E2.183 Referencing APTA Guideline TS 56.2 Operator's Area:

- (a) The bus interior climate control system shall deliver at least 100 cfm of air to the operator's area when operating in the ventilating and cooling modes. Adjustable nozzles shall permit variable distribution and shutdown of the airflow must be done with a positive open/close damper valve. Airflow in the heating mode shall be reduced proportionally to the reduction of airflow into the passenger area. The windshield defroster unit shall meet the requirements of SAE Recommended Practice J382, "Windshield Defrosting Systems Performance Requirements," and shall have the capability of diverting heated air to the operator's feet and legs. The defroster or interior climate control system shall maintain visibility through the operator's side window.

E2.184 Referencing APTA Guideline TS 56.3 Controls for the Climate Control System (CCS):

- (a) The controls for the operator's compartment for heating, ventilation and cooling systems shall be integrated and shall meet the following requirements:
 - (i) **The heat/defrost system fan shall be controlled by a separate switch that has an "off" position and at least three positions for speed control. All switches and controls shall preclude the possibility of clothing becoming entangled, and shields shall be provided, if required. The defroster fan shall provide a sufficient volume of air to maintain a clear windshield in all operating conditions.**
 - (ii) **A manually operated control valve shall control the coolant flow through the heater core. The cable length shall be kept to a minimum to reduce cable seizing. Heater water control valves shall be "positive" type, closed or open. The method of operating remote valves shall require the concurrence of the City project manager.**

E2.185 Referencing APTA Guideline TS 56.4 Operator's Compartment Requirements:

- (a) A separate heating, ventilation and defroster system for the operator's area shall be provided and shall be controlled by the operator. The system shall meet the following requirements:
 - (i) The heater and defroster system shall provide heating for the operator and heated air to completely defrost and defog the windshield, operator's side window, and the front door glasses in all operating conditions without the use of dash fans. Fan(s) shall be able to draw air from the bus body interior and/or the exterior through a control device and pass it through the heater core to the defroster system and over the operator's feet. The defroster unit shall provide a minimum capacity of 550 cfm. The operator shall have complete control of the heat and fresh airflow for the operator's area.
 - (ii) The defroster supply outlets shall be located at the lower edge of the windshield. These outlets shall be durable and shall be free of sharp edges that can catch

clothes during normal daily cleaning. The system shall be such that foreign objects such as coins or tickets cannot fall into the defroster air outlets. Adjustable ball vents or louvers shall be provided at the left of the operator's position to allow direction of air onto the side windows.

- (iii) A ventilation system shall be provided to ensure operator comfort and shall be capable of providing fresh air in both the foot and head areas. Vents shall be controllable by the operator from the normal driving position. Decals shall be provided, indicating "operating instructions" and "open" and "closed" positions. When closed, vents shall be sealed to prevent the migration of water or air into the bus.
- (iv) **Dash Fans: there shall be 2 dash fans. One located center dash and the other located overhead left side of driver's compartment.**

E2.186 Referencing APTA Guideline TS 57. Air Filtration:

- (a) **Air shall be 100% filtered before entering the heat exchangers.**
- (b) The filter shall meet the ANSI/ASHRAE 52.1 requirement for 5 percent or better atmospheric dust spot efficiency, 50 percent weight arrestance, and a minimum dust holding capacity of 120 g per 1000 cfm cell. Air filters shall be easily removable for service.
- (c) Cleanable Filters:
 - (i) Main roof heater air filters shall be cleanable.
- (d) Disposable Type Filters:
 - (i) Air filters shall be of disposable type for the floor heaters and defroster.

E2.187 Referencing APTA Guideline TS 58. Roof Ventilators:

- (a) One roof ventilator shall be provided in the roof of the bus, approximately over the rear axle.
- (b) The ventilator shall be easily opened and closed manually. When open with the bus in motion, this ventilator shall provide fresh air inside the bus. The ventilator shall cover an opening area no less than 425 sq. in. and shall be capable of being positioned as a scoop with either the leading or trailing edges open no less than 4 in., or with all four edges raised simultaneously to a height of no less than 3½ in. An escape hatch shall be incorporated into the roof ventilator. Roof ventilator(s) shall be sealed to prevent entry of water when closed.
- (c) A tool shall be provided to manually open and close the hatch. The tool shall allow safe operation for people ranging in size from a 95th-percentile male to a 5th-percentile female.

E2.188 Referencing APTA Guideline TS 59. Maintainability:

- (a) **A/C Compressor shall have a self-adjusting belt tensioner.**
- (b) Manually controlled service valves in the refrigerant lines shall allow isolation of the compressor and dehydrator filter for service. To the extent practicable, self-sealing couplings utilizing O-ring seals shall be used to break and seal the refrigerant lines during removal of major components, such as the refrigerant compressor. Service valves may be provided in lieu of self-sealing couplings. The condenser shall be located to efficiently transfer heat to the atmosphere and shall not ingest air warmed above the ambient temperature by the bus mechanical equipment, or to discharge air into any other system of the bus. The location of the condenser shall preclude its obstruction by wheel splash, road dirt or debris. HVAC components located within 6 inches of floor level shall be constructed to resist damage and corrosion.

E2.189 Referencing APTA Guideline TS 60. Entrance/exit Area Heating:

- (a) Entrance/Exit Area Heating:
 - (i) Heat shall be supplied to the entrance and exit areas to maintain a tread surface temperature no less than 35 °F in an ambient of -10 °F to prevent accumulation of snow, ice or slush with the bus operating under design operating profile and corresponding door opening cycle.

- (ii) **Defroster speed must be full speed when entrance door is open.**
- (iii) **Entrance door ramp heater must be supplied. The entrance heater is a fin-type heater core, single speed blade type blower fan, in a shroud assembly that is mounted at floor level against the front of the vehicle and cannot interfere with ramp operations and farebox mounting location. The supply and return lines circulate coolant through the heater core. The fan is operational in any defroster speed settings while calling for heat.**

E2.190 Referencing APTA Guideline TS 61. Floor-Level Heating:

- (a) Forced-Air Floor-Level Heating:
 - (i) **Sufficient floor-level heaters shall be provided to evenly supply heated forced air through floor ducts across the length of bus. Floor ducts may be discontinued at the upper level, but additional provisions to prevent cold floors and ensure temperature uniformity shall be included. Control of the floor-level heating shall be through the main heating system electronic control. The floor-level heater shall be controlled independently of the main unit with its own Thermo-King Floor Control Module.**

EXTERIOR PANELS, FINISHES AND EXTERIOR LIGHTING

E2.191 Referencing APTA Guideline TS 62. Design:

- (a) The bus shall have a clean, smooth, simple design, primarily derived from bus performance requirements and passenger service criteria. The exterior and body features, including grilles and louvers, shall be shaped to facilitate cleaning by automatic bus washers without snagging washer brushes. Water and dirt shall not be retained in or on anybody feature to freeze or bleed out onto the bus after leaving the washer. The body and windows shall be sealed to prevent leaking of air, dust or water under normal operating conditions and during cleaning in automatic bus washers for the service life of the bus.
- (b) Exterior panels shall be sufficiently stiff to minimize vibration, drumming or flexing while the bus is in service. When panels are lapped, the upper and forward panels shall act as a watershed. However, if entry of moisture into the interior of the vehicle is prevented by other means, then rear cap panels may be lapped otherwise. The windows, hatches and doors shall be able to be sealed. Accumulation of air spray and splash generated by the bus's wheels shall be minimized on windows and mirrors.

E2.192 Referencing APTA Guideline TS 62.1 Materials:

- (a) Body materials shall be selected and the body fabricated to reduce maintenance, extend durability and provide consistency of appearance throughout the service life of the bus. Detailing shall be kept simple, and add-on devices and trim shall be minimized and integrated into the basic design.

E2.193 Referencing APTA Guideline TS 62.2 Roof-Mounted Equipment:

- (a) A non-skid, clearly marked walkway or steps shall be incorporated on the roof to provide access to equipment without damaging any system or bus paneling.

E2.194 Referencing APTA Guideline TS 63. Pedestrian Safety:

- (a) Exterior protrusions along the side and front of the bus greater than ½ in. and within 80 in. of the ground shall have a radius no less than the amount of the protrusion. The exterior rear view mirrors, cameras and required lights and reflectors are exempt from the protrusion requirement. Grilles, doors, bumpers and other features on the sides and rear of the bus shall be designed to minimize toeholds or handholds.
- (b) Exterior protrusions shall not cause a line-of-sight blockage for the operator.

- E2.195 Referencing APTA Guideline TS 64.1 Repair and Replacement Side Body Panels:
- (a) Structural elements supporting exterior body panels shall allow side body panels below the windows to be repaired in lengths not greater than 12.5 ft. **Color matching sealant must be used to match paint scheme.**
 - (b) Easily Replaceable Lower Side Body Panels:
 - (i) The lower section (approximately 17.5 in.) of the side body panels (low-floor buses) or skirt panels (high-floor buses) shall be made of impact-resistant material and shall be easily and quickly replaceable.
- E2.196 Referencing APTA Guideline TS 65. Rain Gutters:
- (a) Rain gutters shall be provided to prevent water flowing from the roof onto the passenger doors and operator's side window. When the bus is decelerated, the gutters shall not drain onto the windshield, operator's side window or door boarding area. Cross-sections of the gutters shall be adequate for proper operation. **Shall be mechanically secured.**
- E2.197 Referencing APTA Guideline TS 66. License Plate Provisions:
- (a) Provisions shall be made to mount standard-size Canada license plates per SAE J686 on the front and rear of the bus. These provisions shall recess the license plates so that they can be cleaned by automatic bus-washing equipment without being caught by the brushes. The rear license plate provision shall be illuminated per SAE J587. **Securing hardware shall be supplied.**
- E2.198 Referencing APTA Guideline TS 66.1 Rub Rails:
- (a) No requirement for rub rails.
- E2.199 Referencing APTA Guideline TS 67. Fender Skirts:
- (a) Features to minimize water spray from the bus in wet conditions shall be included in wheel housing design. Any fender skirts shall be easily replaceable. They shall be flexible if they extend beyond the allowable body width. Wheels and tires shall be removable with the fender skirts in place. **Must be flush mounted to body panel and color matched.**
- E2.200 Referencing APTA Guideline TS 68. Wheel covers:
- (a) Wheel covers not required.
- E2.201 Referencing APTA Guideline TS 68.1 Splash Aprons:
- (a) Standard Splash Aprons:
 - (i) Splash aprons, composed of ¼ in. minimum composition or rubberized fabric, shall be installed behind and/or in front of wheels as needed to reduce road splash and protect underfloor components. The splash aprons shall extend downward to within 6 in. off the road surface at static conditions. Apron widths shall be no less than tire widths. Splash aprons shall be bolted to the bus understructure. Splash aprons and their attachments shall be inherently weaker than the structure to which they are attached. The flexible portions of the splash aprons shall not be included in the road clearance measurements. Splash apron shall be installed as necessary to protect the wheelchair loading device from road splash. Other splash aprons shall be installed where necessary to protect bus equipment.
 - (b) Full width rear splash apron.
 - (c) Other Locations Required:
 - (i) **Splash apron in front of either or both front wheels to reduce splashing on ramp/lift.**
 - (ii) **Splash aprons mounted behind both front wheels.**
 - (iii) **Splash apron mounted forward of lower radiator.**

E2.202 Referencing APTA Guideline TS 69.1 Access Doors:

- (a) Conventional or pantograph hinged doors shall be used for the engine compartment and for all auxiliary equipment compartments including doors for checking the quantity and adding to the engine coolant, engine lubricant and transmission fluid. Access openings shall be sized for easy performance of tasks within the compartment, including tool operating space. Access doors shall be of rugged construction and shall maintain mechanical integrity and function under normal operations throughout the service life of the bus. They shall close flush with the body surface.
- (b) All doors larger than 100 sq. in. shall be hinged at the top or on the forward edge and shall be prevented from coming loose or opening during transit service or in bus washing operations. All access doors shall be retained in the open position by props or counterbalancing with over-center or gas-filled springs with safety props and shall be easily operable by one person. Springs and hinges shall be corrosion resistant. Latch handles shall be flush with, or recessed behind, the body contour and shall be sized to provide an adequate grip for opening. Access doors, when opened, shall not restrict access for servicing other components or systems. If precluded by design, the manufacturer shall provide door design information specifying how the requirements are met.
- (c) **All doors less than 250 sq. in. shall be counterbalancing with over-centering spring. No gas shocks permitted.**
- (d) **Rear engine compartment door must have 2 access doors to access engine dipstick on left side and transmission dipstick on right side. Must have magnets to keep access doors closed with limiting chain t-o prevent access doors from contacting rear engine door.**

E2.203 Referencing APTA Guideline TS 69.3 Access Door Latch/Locks:

- (a) Requirement for Latches on Access Doors:
 - (i) Access doors larger than 100 sq. in. in area shall be equipped with corrosion-resistant flush-mounted latches or locks except for coolant and fuel fill access doors. All such access doors that require a tool to open shall be standardized throughout the vehicle and will require a nominal 5/16 inch square male tool to open or lock. **All hardware shall be secured with 243 Loctite.**

E2.204 Referencing APTA Guideline TS 70.1 Bumper Location:

- (a) Bumpers shall provide impact protection for the front and rear of the bus with the top of the bumper being 28 inches, ± 2.5 inches, above the ground. Bumper height shall be such that when one bus is parked behind another, a portion of the bumper faces will contact each other.

E2.205 Referencing APTA Guideline TS 70.2 Front Bumper:

- (a) No part of the bus, including the bumper, shall be damaged as a result of a 5 mph impact of the bus at curb weight with a fixed, flat barrier perpendicular to the bus's longitudinal centerline. The bumper shall return to its pre-impact shape within 10 minutes of the impact. The bumper shall protect the bus from damage as a result of 6.5 mph impacts at any point by the common carriage with contoured impact surface defined in Figure 2 of FMVSS 301 loaded to 4000 lbs parallel to the longitudinal centerline of the bus. It shall protect the bus from damage as a result of 5.5 mph impacts into the corners at a 30-degree angle to the longitudinal centerline of the bus. The energy absorption system of the bumper shall be independent of every power system of the bus and shall not require service or maintenance in normal operation during the service life of the bus. The bumper may increase the overall bus length specified by no more than 7 inches.
- (b) Standard bumper:
 - (i) Standard repairable bumper.

E2.206 Referencing APTA Guideline TS 70.3 Rear Bumper:

- (a) No part of the bus, including the bumper, shall be damaged as a result of a 2 mph impact with a fixed, flat barrier perpendicular to the longitudinal centerline of the bus. The bumper shall return to its pre-impact shape within 10 minutes of the impact. When using a yard tug with a smooth, flat plate bumper 2 foot wide contacting the horizontal centerline of the rear bumper, the bumper shall provide protection at speeds up to 5 mph, over pavement discontinuities up to 1 inch high, and at accelerations up to 2 mph/sec. The rear bumper shall protect the bus, when impacted anywhere along its width by the common carriage with contoured impact surface defined in Figure 2 of FMVSS 301 loaded to 4000 lbs, at 4 mph parallel to or up to a 30-degree angle to, the longitudinal centerline of the bus. The rear bumper shall be shaped to preclude unauthorized riders standing on the bumper. The bumper shall not require service or maintenance in normal operation during the service life of the bus. The bumper may increase the overall bus length specified by no more than 7 inches.

E2.207 Referencing APTA Guideline TS 70.4 Bumper Material:

- (a) Bumper material shall be corrosion-resistant and withstand repeated impacts of the specified loads without sustaining damage. Visible surfaces shall be black. These bumper qualities shall be sustained throughout the service life of the bus.
- (b) **Painted bumpers will not be accepted.**

E2.208 Referencing APTA Guideline TS 71.1 Finish and Color Appearance:

- (a) All exterior surfaces shall be smooth and free of wrinkles and dents. Exterior surfaces to be painted shall be properly prepared as required by the paint system Supplier prior to application of paint to assure a proper bond between the basic surface and successive coats of original paint for the service life of the bus. Drilled holes and cut-outs in exterior surfaces shall be made prior to cleaning, priming and painting, where possible, to prevent corrosion. The bus shall be completely painted prior to installation of exterior lights, windows, mirrors and other items that are applied to the exterior of the bus. Body filler materials may be used for surface dressing, but not for repair of damaged or improperly fitted panels.
- (b) Paint shall be applied smoothly and evenly with the finished surface free of visible dirt and the following other imperfections:
 - (i) blisters or bubbles appearing in the topcoat film;
 - (ii) chips, scratches, or gouges of the surface finish;
 - (iii) cracks in the paint film;
 - (iv) craters where paint failed to cover due to surface contamination;
 - (v) overspray;
 - (vi) peeling;
 - (vii) runs or sags from excessive flow and failure to adhere uniformly to the surface;
 - (viii) chemical stains and water spots;
 - (ix) dry patch due to incorrect mixing of paint activators; or
 - (x) buffing swirls.
- (c) All exterior finished surfaces shall be impervious to diesel fuel, gasoline and commercial cleaning agents. Finished surfaces shall resist damage by controlled applications of commonly used graffiti-removing chemicals.
- (d) Proper adhesion between the basic surface and successive coats of the original paint shall be measured using an Elcometer adhesion tester as outlined in ASTM D4541-85. Adhesion shall be a minimum 300 ft-lbs. The bus manufacturer shall supply test samples of the exterior surface for each step of the painting process that may be subject to adhesion testing per ASTM G4541-87 and ASTM D4145-85. ASTM D4541-93 may be used for inspection testing during assembly of the vehicle.

- (e) Maintenance-Free Exterior Finish, Color Impregnated Panels or Unpainted Panels:
 - (i) Except for periodic cleaning, exterior surfaces of the bus shall be maintenance-free, permanently colored and not require refinish/repaint for the life of the vehicle. In general, the exterior surfaces shall be white. Durable, peel-resistant, pressure-sensitive appliqués shall be used for any striping and coloring required.

E2.209 Referencing APTA Guideline TS 72. Decals, Numbering and Signing:

- (a) **Monograms, numbers and other special signing shall be applied to the inside and outside of the bus as required by the City. Decals shall be durable and fade, chip and peel resistant. All decals shall be installed per the decal Supplier recommendations. Exact decal locations to be specified by the City at time of build.**
- (b) **Black decal fleet numbers:**
 - (i) **15.24cm (6 inch) high decal numbers required in two (2) locations (1 Street side front of vehicle, 1 Right Rear Corner);**
 - (ii) **10.16cm (4 inch) high decal numbers in two (2) locations (1 Curb side front of the vehicle, 1 front of vehicle curb side) ; and**
 - (iii) **2 sets of 5.08cm (2 inch) decal numbers inside the vehicle (Rear center, front center).**
- (c) Exterior striping and decals including Winnipeg Transit logos, City of Winnipeg crest to be supplied by the City and installed by the Contractor. Specific locations shall be determined by the City prior to production.
 - (i) The City will supply a list of interior and exterior decals including size and location.

E2.210 Referencing APTA Guideline TS 72.1 Passenger Information:

- (a) Accommodation shall be provided for City installed public information system in accordance with 49 CFR, Part 38.35.

E2.211 Referencing APTA Guideline TS 73. Exterior Lighting:

- (a) **Exterior lighting and reflectors shall comply, as applicable, with Part 393, Subpart B of the FMCSA and FMVSS 108.**
- (b) All exterior lights shall be designed to prevent entry and accumulation of moisture or dust. Commercially available LED-type lamps shall be utilized at all exterior lamp locations. Lamps, lenses and fixtures shall be interchangeable to the extent practicable. Two hazard lamps at the rear of the bus shall be visible from behind when the engine service doors are opened. Light lenses shall be designed and located to prevent damage when running the vehicle through an automatic bus washer. Front marker (clearance) lights along with lights located on the roof and sides of the bus shall have protective shields or be of the flush mount type to protect the lens against minor impacts.
- (c) **Exterior lamp test shall be provided with the key on and the engine not running. The test shall be activated by depressing the left and right turn signal switches simultaneously.**
- (d) Standard Lamps:
 - (i) The entire light assemblies shall be specifically coated to protect the light from chemical and abrasion degradation.
- (e) Standard Size:
 - (i) **LED lamps used for tail, brake and turn signal lamps shall be standard grommet mounted; minimum 4 inches.**
 - (ii) **4 tail light arrangement from top to bottom – red (stop/tail), amber (hazard/signal), red (stop/tail), white (reverse).**

E2.212 Referencing APTA Guideline TS 73.1 Backup Light:

- (a) Visible warnings shall inform following vehicles or pedestrians of reverse operation. Visible reverse operation warning shall conform to SAE Standard J593.

- E2.213 Referencing APTA Guideline TS 73.2 Doorway Lighting:
- (a) **Overhead LED light strips are required in entrance and exit door headers. 2 additional LED standee lights to be provided on either side of passenger standee line, lights to operate when doors are open.**
- E2.214 Referencing APTA Guideline TS 73.3 Turn Signals:
- (a) Standard Turn Signals:
- (i) Four (4) Turn-signal lights shall be provided on the front, rear, curb and street sides of the bus in accordance with FMVSS 108 and Part 393, Subpart B of the FMCSA as applicable.
- E2.215 Referencing APTA Guideline TS 73.4 Headlights:
- (a) Headlamps shall be designed for ease of replacement.
- (b) Sealed beams with daytime Running Lights:
- (i) Headlamps shall incorporate a daytime running light feature. Standard OEM headlight installation shall be provided in accordance with FMVSS 108 and Part 393, Subpart B of the FMCSA as applicable.
- (c) Headlamps shall be LED and/or a combination of LED low beam and high intensity halogens.
- E2.216 Referencing APTA Guideline TS 73.5.1 Brake Lights:
- (a) Brake lights shall be provided in accordance with FMVSS 108 and Part 393, Subpart B of the FMCSA as applicable.
- (b) No High/Center Mount Brake Lamp or Deceleration Warning Lamps.
- (i) Bus shall not include a high/center mount brake lamp and/or deceleration warning indicator lamps.
- E2.217 Referencing APTA Guideline TS 73.6 Service Area Lighting (Interior and Exterior):
- (a) LED lamps shall be provided in the engine and all other compartments where service may be required to generally illuminate the area for night emergency repairs or adjustments. These service areas shall include, but not be limited to, the engine compartment, the communication box, junction/apparatus panels and passenger door operator compartments. Lighting shall be adequate to light the space of the service areas to levels needed to complete typical emergency repairs and adjustments. The service area lamps shall be suitable for the environment in which they are mounted.
- (b) Engine compartment lamps shall be controlled by a switch mounted near the rear start controls. All other service area lamps shall be controlled by switches mounted on or convenient to the lamp assemblies. Power to the service area lighting shall be programmable. Power shall latch on with activation of the switch and shall be automatically discontinued (timed out) after 30 minutes to prevent damage caused by inadvertently leaving the service area lighting switch in the on position after repairs are made.

INTERIOR PANELS AND FINISHES

- E2.218 Referencing APTA Guideline TS 74. General Requirements:
- (a) Materials shall be selected on the basis of maintenance, durability, appearance, safety, flammability and tactile qualities. Materials shall be strong enough to resist everyday abuse and be vandalism and corrosion resistant. Trim and attachment details shall be kept simple and unobtrusive. Interior trim shall be secured to avoid resonant vibrations under normal operational conditions.
- (b) Interior surfaces more than 10 inches below the lower edge of the side windows or windshield shall be shaped so that objects placed on them fall to the floor when the coach is parked on a level surface. Any components and other electrical components within close proximity to these surfaces shall also be resistant to this cleaning method.

- (c) No requirement for anti-graffiti/vandalism surface treatments.

E2.219 Referencing APTA Guideline TS 75. Interior Panels:

- (a) Panels shall be easily replaceable and tamper-resistant. They shall be reinforced, as necessary, to resist vandalism and other rigors of transit bus service. Individual trim panels and parts shall be interchangeable to the extent practicable.
- (b) Interior panel required to meet FMVSS 302.
- (c) Interior side panels shall be Melamine-type material.

E2.220 Referencing APTA Guideline TS 75.1 Operator Area Barrier:

- (a) A barrier or bulkhead between the operator and the street-side front passenger seat shall be provided. The barrier shall minimize glare and reflections in the windshield directly in front of the barrier from interior lighting during night operation. Location and shape must permit full seat travel and reclining possibilities that can accommodate the shoulders of a 95th-percentile male. The partition shall have a side return and stanchion to prevent passenger from reaching the operator by standing behind the operator's seat. The lower area between the seat and panel must be accessible to the operator. The partition must be strong enough in conjunction with entire partition assembly for mounting of such equipment as flare kits, fire extinguishers (1.2 kg), microcomputer, public address amplifier, etc. Dark or black panels are preferred behind the operator's head. The panel should be isolated for noise control and attached with rubber grommets.
- (b) The operator's barrier shall extend from the operator floor to the ceiling and shall fit close to the bus side windows and wall to prevent passengers from reaching the operator or the operator's personal effects. The barrier shall also extend from the bus wall to the first stanchion immediately behind the operator to provide security to the operator and limit passenger conversation.
- (c) **The operator area shall be closed off with an Arow Global Safety barrier with an adjustable window. Windows will be made of shatter proof glass. Must have lower anti-rattle stopper to prevent door defection.**
- (d) **There must be a draft panel located between the farebox and operator compartment.**

E2.221 Referencing APTA Guideline TS 75.2 Modesty Panels:

- (a) Sturdy divider panels constructed of durable, unpainted, corrosion-resistant material complementing the interior shall be provided to act as both a physical and visual barrier for seated passengers.
- (b) Design and installation of modesty panels located in front of forward-facing seats shall include a handhold or grab handle along its top edge. These dividers shall be mounted on the sidewall and shall project toward the aisle no farther than passenger knee projection in longitudinal seats or the aisle side of the transverse seats. Modesty panels shall extend from at least the window opening of the side windows, and those forward of transverse seats shall extend downward to 1 and 1½ in. above the floor. Panels forward of longitudinal seats shall extend to below the level of the seat cushion. Dividers positioned at the doorways shall provide no less than a 2½ inch clearance between the modesty panel and a fully open, inward opening door, or the path of a deploying flip-out ramp to protect passengers from being pinched. Modesty panels installed at doorways shall be equipped with grab rails if passenger assist are not provided by other means.
- (c) The modesty panel and its mounting shall withstand a static force of 250 lbs applied to a 4 x 4 in. area in the center of the panel without permanent visible deformation.
- (d) Clear non-glass panel from above the rear door modesty panels to the top of the daylight opening and attached to the stanchion.

E2.222 Referencing APTA Guideline TS 75.3 Front End:

- (a) The entire front end of the bus shall be sealed to prevent debris accumulation behind the dash and to prevent the operator's feet from kicking or fouling wiring and other equipment. The front end shall be free of protrusions that are hazardous to passengers standing at the front of the standee line area of the bus during rapid decelerations. Paneling across the front of the bus and any trim around the operator's compartment shall be formed metal or composite material. Composite dash panels shall be reinforced as necessary, vandal-resistant and replaceable. All colored, painted and plated parts forward of the operator's barrier shall be finished with a surface that reduces glare. Any mounted equipment must have provision to support the weight of equipment.

E2.223 Referencing APTA Guideline TS 75.4 Rear Bulkhead:

- (a) The rear bulkhead and rear interior surfaces shall be material suitable for exterior skin, paneled with melamine-type material, and trimmed with stainless steel, aluminum or composite.
- (b) The rear bulkhead paneling shall be contoured to fit the ceiling, side walls and seat backs so that any litter or trash will tend to fall to the floor or seating surface when the bus is on a level surface. Any air vents in this area shall be louvered to reduce airflow noise and to reduce the probability of trash or litter being thrown or drawn through the grille. If it is necessary to remove the panel to service components located on the rear bulkhead, the panel shall be hinged or shall be able to be easily removed and replaced. Grilles where access to or adjustment of equipment is required shall be heavy-duty and designed to minimize damage and limit unauthorized access.

E2.224 Referencing APTA Guideline TS 75.5 Headlining:

- (a) Ceiling panels shall be made of durable, corrosion resistant, easily cleanable material. Headlining shall be supported to prevent buckling, drumming or flexing and shall be secured without loose edges. Headlining materials shall be treated or insulated to prevent marks due to condensation where panels are in contact with metal members. Moldings and trim strips, as required to make the edges tamperproof, shall be stainless steel, aluminum or plastic, colored to complement the ceiling material. Headlining panels covering operational equipment that is mounted above the ceiling shall be on hinges for ease of service but retained to prevent inadvertent opening.
- (b) **Must be smooth surface for ease of cleaning.**

E2.225 Referencing APTA Guideline TS 75.6 Fastening:

- (a) Interior panels shall be attached so that there are no exposed unfinished or rough edges or rough surfaces. Fasteners should be corrosion resistant. Panels and fasteners shall not be easily removable by passengers. Exposed interior fasteners should be minimized.

E2.226 Referencing APTA Guideline TS 75.7 Insulation:

- (a) Any insulation material used between the inner and outer panels shall minimize the entry and/or retention of moisture. Insulation properties shall be unimpaired during the service life of the bus. Any insulation material used inside the engine compartment shall not absorb or retain oils or water and shall be designed to prevent casual damage that may occur during maintenance operations.
- (b) The combination of inner and outer panels on the sides, roof, wheel wells and ends of the bus, and any material used between these panels, shall provide a thermal insulation sufficient to meet the interior temperature requirements. The bus body shall be thoroughly sealed so that the operator or passengers cannot feel drafts during normal operations with the passenger doors closed **and to prevent condensation from accumulating.**
- (c) FMVSS 302 requirements:
 - (i) Insulation shall meet the requirements of FMVSS 302.

E2.227 Referencing APTA Guideline TS 75.8 Floor Covering:

- (a) **The floor covering shall have a non-skid walking surface that remains effective in all weather conditions. The floor covering, as well as transitions of flooring material to the main floor and to the entrance and exit area, shall be smooth and present no tripping hazards. Seams shall be welded per manufacturer's specifications. The standee line shall be approximately 2 inches wide and shall extend across the bus aisle. The color and pattern shall be consistent throughout the floor covering.**
- (b) The floor shall be easily cleaned and shall be arranged to minimize debris accumulation.
- (c) A one-piece center strip shall extend from the vertical wall of the rear settee between the aisle sides of transverse seats to the standee line. If the floor is of a bi-level construction, then the center strip shall be one piece at each level. The covering between the center strip and the wheel housings may be separate pieces. At the rear door, however, a separate strip as wide as the door shall extend from the center strip to the outboard edge of the rear/exit area.
- (d) The floor under the seats shall be covered with smooth surface flooring material. The floor covering shall closely fit the sidewall in a fully sealed butt joint or extend to the top of the cove to prevent water intrusion under the flooring material to sub-floor.

E2.228 Referencing APTA Guideline TS 75.9 Interior Lighting:

- (a) The light source shall be located to minimize windshield glare, with distribution of the light focused primarily on the passengers' reading plane while casting sufficient light onto the advertising display. The lighting system may be designed to form part of or the entire air distribution duct.
- (b) The lens material shall be translucent polycarbonate. Lenses shall be designed to effectively "diffuse" the light source. Lenses shall be sealed to inhibit incursion of dust and insects yet be easily removable for service. Access panels shall be provided to allow servicing of components located behind light panels. If necessary, the entire light fixture shall be hinged.
- (c) **External power supply connection at curb side rear, with a safety interlock, shall be provided to enable the operation of the interior lights.**

E2.229 Referencing APTA Guideline TS 75.10 Passenger:

- (a) **Automatically Dimming Interior Lights:**
 - (i) **The first 6 feet on each side (behind the operator and the front door) is; Turned on when the front door is opened.**
- (b) **Turns off when;**
 - (i) **the door is closed;**
 - (ii) **vehicle reaches 2 km/h; and**
 - (iii) **elapsed 10 seconds.**
- (c) **The interior lighting design shall require the approval of the City. The first 2 banks of interior light covers shall be blue and the rest white. All interior lighting shall be turned off whenever the transmission selector is in reverse and the engine run switch is in the "on" position.**
- (d) LED lights.

E2.230 Referencing APTA Guideline TS 75.11 Operator Area:

- (a) The operator's area shall have a light to provide general illumination, and it shall illuminate the half of the steering wheel nearest the operator to a level of 5 to 10 foot-candles.

- E2.231 Referencing APTA Guideline TS 75.12 Seating Areas:
- (a) The interior lighting system shall provide a minimum 15 foot-candle illumination on a 1 sq. ft. plane at an angle of 45 degrees from horizontal, centered 33 inches above the floor and 24 inches in front of the seat back at each seat position. Allowable average light level for the rear bench seats shall be 7 foot-candles.
- E2.232 Referencing APTA Guideline TS 75.14 Vestibules/Doors:
- (a) Floor surface in the aisles shall be a minimum of 10 foot-candles, and the vestibule area a minimum of 4 foot-candles with the front doors open and a minimum of 2 foot-candles with the front doors closed. The front entrance area and curb lights shall illuminate when the front door is open and master run switch is in the "lights" positions. Rear exit area and curb lights shall illuminate when the rear door is unlocked.
- E2.233 Referencing APTA Guideline TS 75.16 Step Lighting:
- (a) Step lighting for the intermediate steps between lower and upper floor levels shall be a minimum of 4 foot-candles and shall illuminate in all engine run positions. The step lighting shall be low-profile to minimize tripping and snagging hazards for passengers and shall be shielded as necessary to protect passengers' eyes from glare.
- E2.234 Referencing APTA Guideline TS 75.17 Ramp Lighting:
- (a) Exterior and interior ramp lighting shall comply with CFR Part 49, Sections 19.29 and 19.31.
- E2.235 Referencing APTA Guideline TS 75.19 Farebox Lighting:
- (a) A light fixture shall be mounted in the ceiling above the farebox location. The fixture shall be capable of projecting a concentrated beam of light on the farebox. This light will automatically come on whenever the front doors are opened and the run switch is in the "night run" or "night park" position.
- E2.236 Referencing APTA Guideline TS 76. Fare Collection:
- (a) **Space and structural provisions shall be made for installation of GFI GenFare Odyssey fare collection devices and shall be as far forward as practicable. Location of the fare collection device shall not restrict traffic in the vestibule, including wheelchairs if a front door loading device is used, and shall allow the operator to easily reach the farebox controls and to view the fare register. The fare box shall not restrict access to the operator area, shall not restrict operation of operator controls and shall not — either by itself or in combination with stanchions, transfer mounting, cutting and punching equipment, or route destination signs — restrict the operator's field of view per SAE Recommended Practice J1050. The location and mounting of the fare collection device shall allow use, without restriction, by passengers. The fare box location shall permit accessibility to the vault for easy manual removal or attachment of suction devices. Meters and counters on the fare box shall be readable on a daily basis. The floor under the fare box shall be reinforced as necessary to provide a sturdy mounting platform and to prevent shaking of the fare box.**
 - (b) **The City will install its own fare box. The location to be determined with the City.**
- E2.237 Referencing APTA Guideline TS 77. Interior Access Panels and Doors:
- (a) Access for maintenance and replacement of equipment shall be provided by panels and doors that appear to be an integral part of the interior. Access doors shall be hinged with gas props, where practical, to hold the doors out of the mechanic's way. Panels shall prevent entry of mechanism lubricant into the bus interior. All fasteners that retain access panels shall be captive in the cover.
 - (b) Access Doors that Do Not Require Tools or Keys to Open (forward of front standee line).
 - (i) Access doors shall be secured with hand screws or latches. All fasteners that retain access panels shall be captive in the cover.

- (c) Access Doors with Locks (rearward of the front standee line).
 - (i) Access doors shall be secured with locks. The locks shall be standardized so that only one tool is required to open access doors on the bus.

REFERENCING APTA GUIDELINE TS 78 PASSENGER SEATING:

E2.238 Referencing APTA Guideline TS 78.1 Arrangements and Seat Style:

- (a) **The passenger seating shall be 4ONE Gemini seats. The seating arrangement in the bus shall be such that seating capacity is maximized and in compliance to the following requirements.**
- (b) Forward-Facing Seat Configuration:
 - (i) Passenger seats shall be arranged in a transverse, forward-facing configuration, except at the wheel housings, where aisle-facing seats may be arranged as appropriate with due regard for passenger access and comfort. Aisle-facing seats shall be provided at wheelchair securement areas and platforms (such as for fuel tank storage space). **Aisle-facing flip up seats, in the upright position, shall not protrude more than 8 inches from the exterior wall.**

E2.239 Referencing APTA Guideline TS 78.2 Rearward Facing Seats:

- (a) Rearward facing seats configuration is not allowed for forty (40) foot buses.
- (b) **Optional purchase of sixty (60) ft. articulated buses will allow rearward facing seats located on the center wheel well forward of the articulated joint. Four (4) seats in total.**

E2.240 Referencing APTA Guideline TS 78.4 Padded Inserts/Cushioned Seats:

- (a) Padded Inserts:
 - (i) The passenger seats shall be equipped with vandal-resistant padded inserts throughout the bus (measure to uncompressed surface).
- (b) **Inserts are Morbern Ambassador ULS WV-205 Freestyle blue vinyl - 6111304.**

E2.241 Referencing APTA Guideline TS 78.5 Seat back fitness

- (a) Cushioned back:
 - (i) Seating and interior trim shall have features to improve passenger comfort. The seat cushion and back shall be padded with a cellular foam product and is no less than ½-in. thick in areas contacted and loaded by passengers in the normal seated position and shall be covered with fabric material.
 - (ii) Seats, back cushions and other pads shall be securely attached and shall be detachable by means of a simple release mechanism so that they are easily removable by the maintenance staff but not by passengers. To the extent practicable, seat cushions and pads shall be interchangeable throughout the bus. Materials shall have high resistance to tearing, flexing and wetting.

E2.242 Referencing APTA Guideline TS 78.5 Drain Hole in Seats:

- (a) Requirement for Drain Hole Provision in Seat Inserts:
 - (i) Provisions, such as a small grommet hole, to allow drainage shall be incorporated into seat insert. (drain through hole – ¼ in. through hole, bottom seat only, one per seat)

E2.243 Referencing APTA Guideline TS 78.8 Hip-to-Knee Room:

- (a) Hip-to-knee room measured from the center of the seating position, from the front of one seat back horizontally across the highest part of the seat to vertical surface immediately in front, shall be a minimum of 26 inches. At all seating positions in paired transverse seats immediately behind other seating positions, hip-to-knee room shall be no less than 27 inches.

E2.244 Referencing APTA Guideline TS 78.9 Foot Room:

- (a) Foot room, measured at the floor forward from a point vertically below the front of the seat cushion, shall be no less than 14 inches. Seats immediately behind the wheel housings and modesty panels may have foot room reduced.

E2.245 Referencing APTA Guideline TS 78.10 Aisles:

- (a) The aisle between the seats shall be no less than 20 inches wide at seated passenger hip height. Seat backs shall be shaped to increase this dimension to no less than 24 inches at 32 inches above the floor (standing passenger hip height).

E2.246 Referencing APTA Guideline TS 78.12 Dimensions:

- (a) Seat dimensions for the various seating arrangements shall have the dimensions as follows (refer to Figure 6):
 - (i) The width, W, of the two-passenger transverse seat shall be a minimum 35 in.
 - (ii) The length, L, shall be 17 in., ± 1 in.
 - (iii) The seat back height, B, shall be a minimum of 15 in.
 - (iv) The seat height, H, shall be 17 in., ± 1 in. For the rear lounge (or settee) and longitudinal seats, and seats located above raised areas for storage of under-floor components, a cushion height of up to 18 in., ± 2 in., will be allowed. This shall also be allowed for limited transverse seats, but only with the expressed approval of the City.
 - (v) Foot room = F = 14 in.
 - (vi) The seat cushion slope, S, shall be between 5 and 11 degrees.
 - (vii) The seat back slope, C, shall be between 8 and 17 degrees.
 - (viii) Hip to knee room = K = 27 in.
 - (ix) The pitch, P, is shown as reference only.
- (b) Figure 6.

FIGURE 6

Seating Dimensions and Standard Configuration

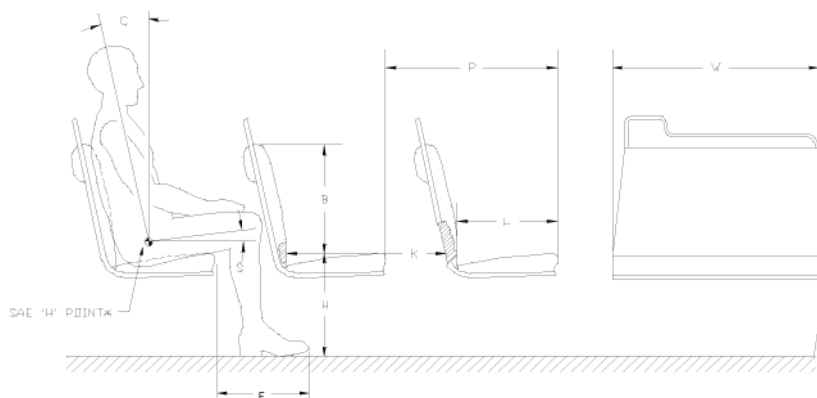

E2.247 Referencing APTA Guideline TS 78.13 Structure and Design:

- (a) The passenger seat frame and its supporting structure shall be constructed and mounted so that space under the seat is maximized and is completely free of obstructions to facilitate cleaning.
- (b) Seats, structures and restraints around the securement area should not infringe into the mobility device envelope or maneuverability.

- (c) The transverse seat structure shall be fully cantilevered from the sidewall with sufficient strength for the intended service. The lowest part of the seat assembly that is within 12 inches of the aisle shall be at least 10 inches above the floor.
- (d) In locations at which cantilevered installation is precluded by design and/or structure, other seat mounting may be allowed.
- (e) All transverse objects — including seat backs, modesty panels, and longitudinal seats — in front of forward-facing seats shall not impart a compressive load in excess of 1000 lb onto the femur of passengers ranging in size from a 5th-percentile female to a 95th-percentile male during a 10g deceleration of the bus. This deceleration shall peak at 0.05 to 0.015 seconds from initiation. Permanent deformation of the seat resulting from two 95th-percentile males striking the seat back during this 10g deceleration shall not exceed 2 inches, measured at the aisle side of the seat frame at height H. The seat back should not deflect more than 14 inches, measured at the top of the seat back, in a controlled manner to minimize passenger injury. Structural failure of any part of the seat or sidewall shall not introduce a laceration hazard.
- (f) The seat assembly shall withstand static vertical forces of 500 lbs applied to the top of the seat cushion in each seating position with less than ¼-inch permanent deformation in the seat or its mountings. The seat assembly shall withstand static horizontal forces of 500 lbs evenly distributed along the top of the seat back with less than ¼-in. permanent deformation in the seat or its mountings. The seat backs at the aisle position and at the window position shall withstand repeated impacts of two 40-lb sandbags without visible deterioration. One sandbag shall strike the front 40,000 times and the other sandbag shall strike the rear 40,000 times. Each sandbag shall be suspended on a 36-inch pendulum and shall strike the seat back 10,000 times each from distances of 6, 8, 10 and 12 inches. Seats at both seating positions shall withstand 4000 vertical drops of a 40-lb sandbag without visible deterioration. The sandbag shall be dropped 1000 times each from heights of 6, 8, 10 and 12 inches. Seat cushions shall withstand 100,000 randomly positioned 3½-inch drops of a squirming, 150-lb, smooth-surfaced, buttocks-shaped striker with only minimal wear on the seat covering and no failures to seat structure or cushion suspension components.
- (g) The back of each transverse seat shall incorporate a handhold no less than ⅞ inch in diameter for standees and seat access/egress. The handhold shall not be a safety hazard during severe decelerations. The handhold shall extend above the seat back near the aisle so that standees shall have a convenient vertical assist, no less than 4 inch long that may be grasped with the full hand. This handhold shall not cause a standee using this assist to interfere with a seated 50th-percentile male passenger. The handhold shall also be usable by a 5th-percentile female, as well as by larger passengers, to assist with seat access/egress for either transverse seating position. The upper rear portion of the seat back and the seat back handhold immediately forward of transverse seats shall be padded and/or constructed of energy absorbing materials. During a 10 g deceleration of the bus, the HIC number (as defined by SAE Standard J211a) shall not exceed 400 for passengers ranging in size from a 5th percentile female through a 95th percentile male.
- (h) The seat back handhold may be deleted from seats that do not have another transverse seat directly behind and where a vertical assist is provided.
- (i) Longitudinal seats shall be the same general design as transverse seats but without seat back handholds. Longitudinal seats may be mounted on the wheelhouses. Armrests shall be included on the ends of each set of longitudinal seats except on the forward end of a seat set that is immediately to the rear of a transverse seat, the operator's barrier, or a modesty panel, when these fixtures perform the function of restraining passengers from sliding forward off the seat. Armrests are not required on longitudinal seats located in the wheelchair parking area that fold up when the armrest on the adjacent fixed longitudinal seat is within 3½ inches of the end of the seat cushion. Armrests shall be located from 7 to 9 inches above the seat cushion surface. The area between the armrest and the seat cushion shall be closed by a barrier or panel. The top and sides of the armrests shall have a minimum width of 1 inch and shall be free from sharp protrusions that form a safety hazard.

- (j) Seat back handhold and armrests shall withstand static horizontal and vertical forces of 250 lbs applied anywhere along their length with less than ¼-inch permanent deformation. Seat back handhold and armrests shall withstand 25,000 impacts in each direction of a horizontal force of 125 lbs with less than ¼-inch permanent deformation and without visible deterioration.
- (k) **Stainless steel 304 hardware must be used to fasten seat within 12 inches of the floor.**

E2.248 Referencing APTA Guideline TS 78.15 Construction and Materials:

- (a) Selected materials shall minimize damage from vandalism and shall reduce cleaning time. The seats shall be attached to the frame with tamper-resistant fasteners. Coloring shall be consistent throughout the seat material, with no visually exposed portion painted. Any exposed metal touching the sides or the floor of the bus, or within 12 inches of the floor, shall be stainless steel with a minimum grade 304. The seat, pads and cushions shall be contoured for individuality, lateral support and maximum comfort and shall fit the framework to reduce exposed edges.
- (b) The minimum radius of any part of the seat back, handhold or modesty panel in the head or chest impact zone shall be a nominal ¼-inch. The seat back and seat back handhold immediately forward of transverse seats shall be constructed of energy-absorbing materials to provide passenger protection and, in a severe crash, allow the passenger to deform the seating materials in the impact areas. Complete seat assemblies shall be interchangeable to the extent practicable.

E2.249 Referencing APTA Guideline TS 79. Passenger Assists:

- (a) Passenger assists in the form of full grip, vertical stanchions or handholds shall be provided for the safety of standees and for ingress/egress. Passenger assists shall be convenient in location, shape, and size for both the 95th-percentile male and the 5th-percentile female standee. Starting from the entrance door and moving anywhere in the bus and out the exit door, a vertical assist shall be provided either as the vertical portion of seat back assist or as a separate item so that a 5th-percentile female passenger may easily move from one assist to another using one hand and the other without losing support. All handholds and stanchions at front doorway, around farebox, and at interior steps for bi-level designs shall be powder-coated in a high-contrast yellow color.
- (b) **The forward-most vertical stanchions on either side of the aisle immediately behind the operator's area shall be:**
 - (i) **Stainless steel grade 304 on all stanchions, fasteners and accessories.**

E2.250 Referencing APTA Guideline TS 79.1 Assists:

- (a) Excluding those mounted on the seats and doors, the assists shall have a cross-sectional diameter between 1¼ and 1½ inches or shall provide an equivalent gripping surface with no corner radii less than ¼ inch. All passenger assists shall permit a full hand grip with no less than 1½ inch of knuckle clearance around the assist. Passenger assists shall be designed to minimize catching or snagging of clothes or personal items and shall be capable of passing the NHTSA Drawstring Test.
- (b) Any joints in the assist structure shall be underneath supporting brackets and securely clamped to prevent passengers from moving or twisting the assists. Seat handholds may be of the same construction and finish as the seat frame. **Door mounted passenger assists, connecting tees, angles and hardware shall be 304 grade stainless steel.** Assists shall withstand a force of 300 lbs applied over a 12-inch lineal dimension in any direction normal to the assist without permanent visible deformation. All passenger assist components, including brackets, clamps, screw heads and other fasteners used on the passenger assists shall be designed to eliminate pinching, snagging and cutting hazards and shall be free from burrs or rough edges.

E2.251 Referencing APTA Guideline TS 79.2 Front Doorway:

- (a) Front doors, or the entry area, shall be fitted with ADA-compliant assists. Assists shall be as far outward as practicable, but shall be located no farther inboard than 6 inches from the outside edge of the entrance step and shall be easily grasped by a 5th-percentile female boarding from street level. Door assists shall be functionally continuous with the horizontal front passenger assist and the vertical assist and the assists on the wheel housing or on the front modesty panel.

E2.252 Referencing APTA Guideline TS 79.3 Vestibule:

- (a) The aisle side of the operator's barrier, the wheel housings, and when applicable the modesty panels shall be fitted with vertical passenger assists that are functionally continuous with the overhead assist and that extend to within 36 inches of the floor. These assists shall have sufficient clearance from the barrier to prevent inadvertent wedging of a passenger's arm.
- (b) A horizontal passenger assist shall be located across the front of the bus and shall prevent passengers from sustaining injuries on the front dash or windshield in the event of a sudden deceleration. Without restricting the vestibule space, the assist shall provide support for a boarding passenger from the front door through the fare collection procedure. The assist shall be no less than 36 inches above the floor. The assists at the front of the bus shall be arranged to permit a 5th-percentile female passenger to easily reach from the door assist, to the front assist, to vertical assists on the operator's barrier, wheel housings or front modesty panel.

E2.253 Referencing APTA Guideline TS 79.4 Rear Doorway(s):

- (a) Vertical assists that are functionally continuous with the overhead assist shall be provided at the aisle side of the transverse seat immediately forward of the rear door and on the aisle side of the rear door modesty panel(s). Passenger assists shall be provided on modesty panels that are functionally continuous with the rear door assists. Rear doors, or the exit area, shall be fitted with assists having a cross-sectional diameter between 1¼ and 1½ inches or providing an equivalent gripping surface with no corner radii less than ¼ inch, and shall provide at least 1½ inches of knuckle clearance between the assists and their mounting. The assists shall be designed to permit a 5th-percentile female to easily move from one assist to another during the entire exiting process. The assists shall be located no farther inboard than 6 in. from the outside edge of the rear doorway step.
- (b) Articulated bus, passenger assists will be provided to aid in the transition between the front and rear sections of the bus.

E2.254 Referencing APTA Guideline TS 79.5 Overhead:

- (a) Except forward of the standee line and at the rear door, a continuous, full grip, overhead assist shall be provided. This assist shall be located over the center of the aisle seating position of the transverse seats. The assist shall be no less than 70 inches above the floor.
- (b) Overhead assists shall simultaneously support 150 lbs on any 12-inch length. No more than 5 percent of the full grip feature shall be lost due to assist supports.
- (c) Grab Straps:
 - (i) Grab straps or other extensions as necessary shall be provided for sections where vertical assists are not available and for the use by passengers that cannot reach to 70 inches. The lower portion of the grab strap shall not be higher than 60 inches.
- (d) **Grab straps shall be:**
 - (i) **Plastic or Vinyl;**
 - (ii) **Grey; and**
 - (iii) **Capable of withstanding a tensile load stress of 500 lbs without failure or distortion.**

E2.255 Referencing APTA Guideline TS 79.6 Longitudinal Seat Assists:

- (a) Longitudinal seats shall have vertical assists located between every other designated seating position, except for seats that fold/flip up to accommodate wheelchair securement. Assists shall extend from near the leading edge of the seat and shall be functionally continuous with the overhead assist. Assists shall be staggered across the aisle from each other where practicable and shall be no more than 52 inches apart or functionally continuous for a 5th percentile female passenger.

E2.256 Referencing APTA Guideline TS 79.7 Wheel Housing Barriers/Assists:

- (a) Unless passenger seating is provided on top of wheel housing, passenger assists shall be mounted around the exposed sides of the wheel housings (and propulsion compartments if applicable), which shall also be designed to prevent passengers from sitting on wheel housings. Such passenger assists shall also effectively retain items, such as bags and luggage, placed on top of wheel housing.

E2.257 Referencing APTA Guideline TS 80.1. Passenger Doors:

- (a) Doorways will be provided in the locations and styles as follows. Passenger doors and doorways shall comply with ADA requirements.
- (b) **Air powered door system shall operate per specification at air pressures between 90 and 130 psi.**

E2.258 Referencing APTA Guideline TS 80.1.1 Front Door:

- (a) Door shall be forward of the front wheels and under direct observation of the driver.

E2.259 Referencing APTA Guideline TS 80.1.2 Rear doors:

- (a) Curbside doorway centerline located rearward of the point midway between the front door centerline and the rearmost seat back.

E2.260 Referencing APTA Guideline 80.3 Materials and Construction:

- (a) Structure of the doors, their attachments, inside and outside trim panels and any mechanism exposed to the elements shall be corrosion-resistant. Door panel construction shall be of corrosion-resistant metal. When fully opened, the doors shall provide a firm support and shall not be damaged if used as an assist by passengers during ingress or egress. Door edges shall be sealed to prevent infiltration of exterior moisture, noise, dirt and air elements from entering the passenger compartment, to the maximum extent possible based on door types.
- (b) The closing edge of each door panel shall have no less than 2 inches of soft weather stripping. The doors, when closed, shall be effectively sealed, and the hard surfaces of the doors shall be at least 4 inches apart. The combined weather seal and window glazing elements of the front door shall not exceed 10 degrees of binocular obstruction of the operator's view through the closed door.

E2.261 Referencing APTA Guideline TS 80.4.1 Dimensions:

- (a) When open, the doors shall leave an opening no less than 75.3 inches in height.
 - (i) 31¾-inch Minimum Doorway Clear Width.
- (b) Front door clear width shall be a minimum of 31¾ in. with the doors fully opened. Rear door opening clear width shall be a minimum of 30 inches with the doors fully opened.

(c) Figure 7.

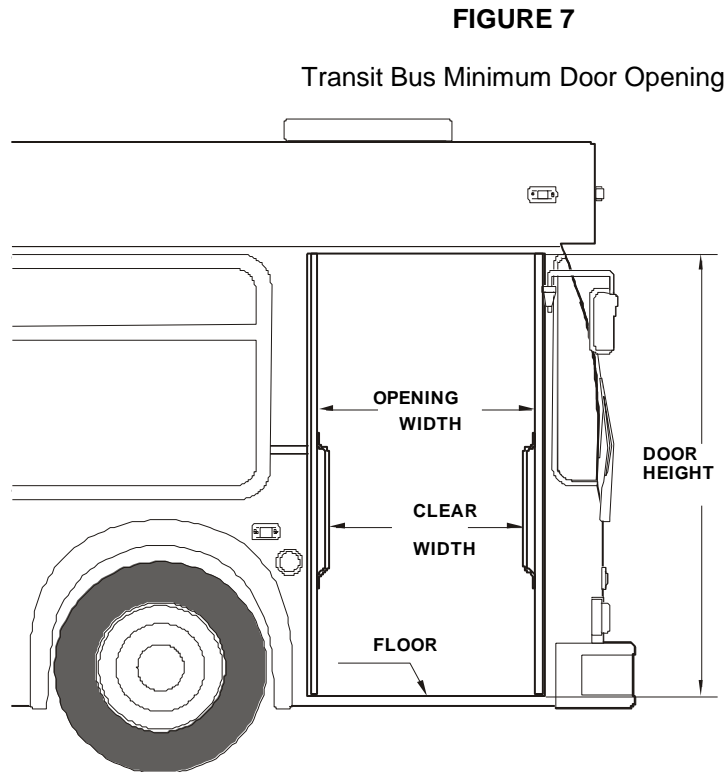

E2.262 Referencing APTA Guideline TS 80.5 Door Glazing:

- (a) The upper section of both front and rear doors shall be glazed for no less than 45 percent of the respective door opening area of each section. The lower section of the front door shall be glazed for no less than 25 percent of the door opening area of the section. **The lower section of the rear door shall not be glazed.**
- (b) Door glazing shall be easily replaceable in a quick change exterior frame.
- (c) The front door panel glazing material shall have a nominal ¼ inch thick laminated safety glass conforming to the requirements of ANSI Z26.1 Test Grouping 2 and the Recommended Practices defined in SAE J673.
- (d) **The rear doorway glazing material shall have a nominal ¼ inch thick laminated safety glass conforming to the requirements of ANSI Z26.1 The rear door shall be tinted gray and have a maximum solar energy transmittance of 44 percent, as measured by ASTM E-424. Luminous transmittance shall be measured by ASTM D-1003.**

REFERENCING APTA GUIDELINE TS 80.6 DOOR PROJECTION

E2.263 Referencing APTA Guideline TS 80.6.1 Exterior:

- (a) **The exterior projection of the front doors beyond the side of the bus shall be minimized and shall not block the line of sight of the rear exit door via the curb side mirror when the doors are fully open. The exterior projection of both doors shall be minimized and shall not exceed 5.25 inches during the opening or closing cycles or when doors are fully opened.**

E2.264 Referencing APTA Guideline TS 80.6.2 Interior:

- (a) Projection inside the bus shall not cause an obstruction of the rear door mirror or cause a hazard for standees.

E2.265 Referencing APTA Guideline TS 80.7 Door Height Above Pavement:

- (a) It shall be possible to open and close either passenger door when the bus loaded to gross vehicle weight rating is not knelt and parked with the tires touching an 8-inch-high curb on a street sloping toward the curb so that the street side wheels are 5 in. higher than the right side wheels.

E2.266 Referencing APTA Guideline TS 80.8 Closing Force:

- (a) Closing door edge speed shall not exceed 12 inches per second, and opening door speed shall not exceed 19 inches per second. Power doors shall not slam closed under any circumstance, even if the door is obstructed during the closing cycle. If a door is obstructed during the closing cycle, the pressure exerted on the obstruction shall not increase once initial contact has been made.
- (b) Doors closed by a return spring or counterweight-type device shall be equipped with an obstruction-sensing device that, at a minimum, alerts the operator if an obstruction is detected between the closing doors. Doors closed by a return spring or counterweight type device, when unlocked, shall be capable of being pushed to the point where the door starts to open with a force not to exceed 25 lbs applied to the center edge of the forward door panel.
- (c) Whether or not the obstruction sensing system is present or functional, it shall be possible to withdraw a 1½ inch diameter cylinder from between the center edges of a closed and locked door with an outward force not greater than 35 lbs.

E2.267 Referencing APTA Guideline TS 80.8.1 Rear Door Closing Force:

- (a) Power-close rear doors shall be equipped with an obstruction sensing system such that if an obstruction is within the path of the closing doors, the doors will stop and/or reverse direction prior to imparting a 10-lb force on 1 sq. in. of that obstruction. If a contactless obstruction sensing system is employed, it shall be capable of discriminating between the normal doorway environment and passengers or other obstructions within the doorway, and of altering the zones of detection based upon the operating state of the door system.

E2.268 Referencing APTA Guideline TS 80.9 Actuators:

- (a) Doors shall open or close completely in 3.5 seconds from the time of control actuation and shall be subject to the closing force requirements.
- (b) Door actuators shall be adjustable so that the door opening and closing speeds can be independently adjustable to satisfy the above requirements. The door actuator shall have a damper adjustment to fully cushion door slamming. Actuators and the complex door mechanism shall be concealed from passengers but shall be easily accessible for servicing. The door actuators shall be rebuild-able. Air exhausted from the door system shall be routed such to prevent accumulation of any oil that may be present in the air system and to muffle sound.
- (c) Door actuators and associated linkages shall maximize door holding forces in the fully open and fully closed positions to provide firm, non-rattling, non-fluttering door panels while minimizing the force exerted by the doors on an obstruction midway between the fully open and closed positions.
- (d) **The rear doors shall be passenger-controlled. The vehicle operator shall unlock and enable the opening mechanism, which shall be annunciated by illumination of a green light near the door. After enabling and unlocking, the doors shall be opened by the passenger by a powered mechanism actuated by passenger activation of a touch bar. A switch located within finger reach of the door control, shall duplicate a passenger activated rear door signal.**
- (e) **Doors that employ a “swing” or pantograph geometry and/or are closed by a return spring or counterweight-type device shall be equipped with a positive mechanical holding device that automatically engages and prevents the actuation mechanism from being back-driven from the fully closed position. The holding device shall be overcome only when the operator’s door control is moved to an “Exit Door Enable”**

position and the vehicle is at 0 km/h, or in the event of actuation of the emergency door release.

- (f) Locked doors shall require a force of more than 300 lbs to open manually. When the locked doors are manually forced to open, damage shall be limited to the bending of minor door linkage with no resulting damage to the doors, actuators or complex mechanism.

Rear door shall be equipped with “drunk alarm” door ajar alarm when rear doors are locked preventing passengers from exiting/pushing rear door.

E2.269 Referencing APTA Guideline TS 80.10 Emergency Operation:

- (a) In the event of an emergency, it shall be possible to manually open doors designated as emergency exits from inside the bus using a force of no more than 25 lbs after actuating an unlocking device. The unlocking device shall be clearly marked as an emergency-only device and shall require two distinct actions to actuate. The respective door emergency unlocking device shall be accessible from the doorway area. The unlocking device shall be easily reset by the operator without special tools or opening the door mechanism enclosure. Doors that are required to be classified as “Emergency Exits” shall meet the requirements of FMVSS 217.

E2.270 Referencing APTA Guideline TS 80.11 Door Control:

- (a) The door control shall be located in the operator’s area within the hand reach envelope described in SAE Recommended Practice J287, “Operator Hand Control Reach.” The operator’s door control shall provide tactile feedback to indicate commanded door position and resist inadvertent door actuation.
- (b) Door control located on street side.
- (c) The front door shall remain in commanded state position even if power is removed or lost.

E2.271 Referencing APTA Guideline TS 80.12.1 Door Controller:

- (a) Five-Position Operator’s Door Controller:
- (i) The control device shall be protected from moisture. Mounting and location of the door control device handle shall be designed so that it is within comfortable, easy arm’s reach of the seated operator. The door control device handle shall be free from interference by other equipment and have adequate clearance so as not to create a pinching hazard.
- (b) Position of the door control handle shall result in the following operation of the front and rear doors:
- (i) Center position: Front door closed, rear door(s) closed or set to lock.
- (ii) First position forward: Front door open, rear door(s) closed or set to lock.
- (iii) Second position forward: Front door open, rear door(s) open or set to open.
- (iv) First position back: Front door closed, rear door(s) open or set to open.
- (v) Second position back: Front door open, rear door(s) open or set to open.

E2.272 Referencing APTA Guideline TS 80.13 Door Open/Close:

- (a) Operator-Controlled Front and Passenger-Controlled Rear Doors with Provision for Operator Override:
- (i) Operation of, and power to, the front passenger doors shall be completely controlled by the operator. Power to rear doors shall be controlled by operator. After enabling, the rear doors shall be opened by the passenger. A switch shall be provided to enable the operator to obtain full control of the rear doors.
- (b) A control or valve in the operator’s compartment shall shut off the power to, and/or dump the power from, the front door mechanism to permit manual operation of the front door with the bus shut down. A master door switch, location approved by the City, when set in the “off” position shall close the rear doors, deactivate the door control system, release the interlocks, and permit only manual operation of the rear doors.

E2.273 Referencing APTA Guideline TS 81. Accessibility Provisions:

- (a) Space and body structural provisions shall be provided at the front of the bus to accommodate a wheelchair loading system.

E2.274 Referencing APTA Guideline TS 81.1 Loading Systems:

- (a) A low floor ramp shall be provided.

E2.275 Referencing APTA Guideline TS 81.3 Loading System for Low-Floor Bus:

- (a) An automatically controlled, power-operated ramp system compliant to requirements defined in 49 CFR Part 38, Subpart B, §38.23c shall provide ingress and egress quickly, safely and comfortably, both in forward and rearward directions, for a passenger in a wheelchair from a level street or curb.
- (b) Front Door Location of Loading System, Flip-Out Design Ramp with 6:1 Slope:
 - (i) The wheelchair loading system shall be located at the front door, with the ramp being of a simple hinged, flip-out type design being capable of deploying to the ground at a maximum 6:1 slope.

E2.276 Referencing APTA Guideline TS 81.5 Wheelchair Accommodations:

- (a) Curbside:
 - (i) The curbside shall be a Q'Straint Quantum automatic rear-facing securement station.
- (b) Streetside:
 - (i) The streetside shall be a Q'Straint Q'Pod 3 point forward-facing securement system with integrated wheelchair securement – Lap, shoulder and self-tensioning rear belts.

E2.277 Referencing APTA Guideline TS 81.6 Interior Circulation:

- (a) Maneuvering room inside the bus shall accommodate easy travel for a passenger in a wheelchair from the loading device and from the designated securement area. It shall be designed so that no portion of the wheelchair protrudes into the aisle of the bus when parked in the designated parking space(s). When the positions are fully utilized, an aisle space of no less than 20 in. shall be maintained. As a guide, no width dimension should be less than 34 in. Areas requiring 90-degree turns of wheelchairs should have a clearance arc dimension no less than 45 in., and in the parking area where 180-degree turns are expected, space should be clear in a full 60-in.-diameter circle. A vertical clearance of 12 in. above the floor surface should be provided on the outside of turning areas for wheelchair footrest.

SIGNAGE AND COMMUNICATION

E2.278 Referencing APTA Guideline TS 83. Destination Signs:

- (a) **Luminator – Horizon Full LED ODK 4 SYSTEM CONTROLLER #510632-004.**
- (b) The ODK shall be conveniently located above the bus operator within reach of the seated position. Display areas of destination signs shall be clearly visible in direct sunlight and/or at night.
- (c) **All display signs will be white LED.**
- (d) Front Sign:
 - (i) **16 X 160 - 8" Front sign White #5108 -001.**
- (e) Front Curb Side Sign:
 - (i) **8 x 96 - 2.8" Side sign White #510847-TBD.**
 - (ii) The sign located near the front door shall not block the operator's critical horizontal line of sight.

- (f) Rear Route Sign:
 - (i) **16 X 48 - 6.1" Rear sign White #510848-001.**
 - (ii) The sign located at the upper curb side.
- (g) The destination sign compartments shall meet the following minimum requirements:
 - (i) Compartments shall be designed to prevent condensation and entry of moisture and dirt;
 - (ii) Compartments shall be designed to prevent fogging of both compartment window and glazing on unit itself;
 - (iii) Access shall be provided to allow cleaning of inside compartment window and unit glazing;
 - (iv) Front window shall have an exterior display area of no less than 11 inch high by 72 inch wide.; and
 - (v) Front exterior Sign glass shall be heated and laminated.

E2.279 Referencing APTA Guideline TS 84.1 Interior Displays:

- (a) Advertising media 11 in. high and 0.09 in. thick shall be retained near the juncture of the bus ceiling and sidewall. The retainers may be concave and shall support the media without adhesives. The media shall be illuminated by the interior light system.
- (b) **Dedicated next stop display location and communication line conduit must be provided and approved by the City.**

E2.280 Referencing APTA Guideline TS 85. Passenger Stop Request/Exit Signal:

- (a) Pull Cord Passenger Signal:
 - (i) A passenger "stop requested" signal system that complies with applicable ADA requirements defined in 49 CFR, part 38.37 shall be provided. The system shall consist of a heavy-duty yellow pull cable, chime and interior sign message. The pull cable shall be located the full length of the bus on the sidewalls at the level where the transom is located. If no transom window is required, the height of the pull cable shall approximate this transom level and shall be no greater than 63 in. as measured from the floor surface. It shall be easily accessible to all passengers, seated or standing. Pull cable(s) shall activate one or more solid state or magnetic proximity switches. At each wheelchair passenger position and at priority seating positions, additional provisions shall be included to allow a passenger in a mobility aid to easily activate the "stop requested" signal.
- (b) **Six (6) auxiliary passenger "stop request" signals shall be installed on vertical seat stanchions to provide standing passengers a convenient means of activating the signal system. Signal locations shall be available at intervals to be approved by the City. The signal shall be a heavy-duty push button type located in the rear door vicinity. Button shall be clearly identified as "passenger signal".**
- (c) **A wheelchair passenger "stop request" signal, located in each securement area, shall be no higher than 3 feet above the floor. Instructions shall be provided to clearly indicate function and operation of these signals. Signal locations to be approved by the City.**

E2.281 Referencing APTA Guideline 85.3 Signal Chime:

- (a) A single "stop requested" chime shall sound when the system is first activated. A double chime shall sound anytime the system is activated from wheelchair passenger areas.

E2.282 Referencing APTA Guideline TS 86. Communications:

- (a) **Communication box behind the operator modesty panel shall have:**
 - (i) **a locked keyed access door;**
 - (ii) **a minimum of 7 cubic feet;**
 - (iii) **shelves must be removable;**

- (iv) shelf space for communication equipment – minimum 1200 sq. inches;
- (v) shelf space for the DVR requiring an area 16"W x18'D x 6 1/2"H =288 sq in. and access to the 16" front to facilitate removing the hard drive chassis;
- (vi) shelf space for the Router requiring the 10"W x 7"D x 4H"; and
- (vii) shelf space for the Radio requiring 7"W x 7"D x 4"H.

E2.283 Referencing APTA Guideline TS 86.1 Camera Surveillance System:

- (a) **Apollo Video Technology is Winnipeg Transit's Video Camera Surveillance System standard.**
- (b) Provide all wiring and mounting locations for a multi-camera surveillance system including the installation, as per OEM specifications, of cables, cameras, recorder, microphone, etc.
- (c) Camera locations:

Location	Camera	Color Camera? (Y/N)	Built in Mic? (Y/N)
Entrance Door	IP 360° HD camera, Wiring prevision, camera to ship loose.	Yes	No
Forward Facing (Windshield)	30. mm-8.5 mm varifocal lens, IP camera	Yes – Daytime, Black and White – Night	No
Auxiliary external Mic, over operator			Yes
Mid bus across from exit door towards light panel street side.	IP 360° HD camera,	Yes	No
Auxiliary Mic. Mid bus located below light panel across from exit door.			Yes
Street side external – rated to operate in - 35°C waterproof	30. mm-8.5 mm varifocal lens, IP camera, painter to match roof panel.	Yes – Daytime, Black and White – Night	No
Curb side external – rated to operate in - 35°C waterproof	30. mm-8.5 mm varifocal lens, IP camera, painter to match roof panel.	Yes – Daytime, Black and White – Night	No

(d) Video requirements:

Camera Surveillance System Supplier	Apollo Video Technology (City Standard for Winnipeg Transit)
DVR	<ul style="list-style-type: none"> • Latest HD Roadrunner (4k) model, approved by the city, capable of recording 1 independent channel of video up to 3840 x 2160 pixels – adjustable for each camera. • Recording rates up to 480 images per seconds at 4K resolution. • 8 independent channels of video • “switching” systems are not acceptable • Minimum four (4) Terabyte hard drive.
Camera System Cable Type	As per OEM and an additional CAT 6-cable to each camera for future use I/P based cameras
Audio	2 external microphones.
Cable Length	Maximum extra cable length – 2 foot each end from panel exit point.
Event Marker Button	Required – Operator initiated, signal and event initiated
User Interface	OSD with remote control, pointing device, web browser
Input Volt (ignition and supply)	24 VDC

(e) The HD Reader Software must be able to save recordings in a proprietary EDS format as well as in a standard AVI format, which can be played back on a standard PC running Windows latest Operating System approved by the City.

(f) Multilevel user-access control and password protection must be available.

(g) The DVR (Niuu) must:

- (i) Be compatible with J1939 (CAN bus) - records and displays up to 10 signals;
- (ii) Support an optional GPS receiver for recording and displaying vehicle position, direction, and speed;
- (iii) Have a built-in fan (reversed to draw clean filtered air into DVR); field-replaceable filter;
- (iv) Have dual stream for lower bandwidth applications for all video channels;
- (v) Have hot-swappable, removable locking drive carrier;
- (vi) Record up to 10 functions (signals) including brake lights, stop lights, warning lights, turn signal, stop arm, wheelchair lift, etc... (user programmable);
- (vii) Be able to transfer recorded video and audio to a removable USB Flash drive;
- (viii) Must come standard with built-in internal heater;
- (ix) Must have high and low temperature protection – the DVR will power up but will not start recording until a safe internal temperature is reached in order to protect temperature sensitive components such as hard drives;
- (x) Must have a Smart-Start power-up protection to prevent damage from voltage transients;
- (xi) Must have a Smart-Temp power-up protection to not start recording until a safe internal temperature is reached;
- (xii) Must contain an onboard accelerometer for logging data related to operator behaviour or collision detection; and
- (xiii) Retrieve accelerometer data via log file or by playing back video synchronized with the accelerometer data to illustrate where vehicles have braked abruptly or have taken hard corners.

E2.284 Referencing APTA Guideline TS 86.2 Public Address System:

- (a) A public address system shall be provided on each bus for facilitating radio system and operator-originated announcements to passengers. **The PA system shall be compatible with the INFODEV radio system installation.**
- (b) **The P.A. system shall be controlled by a floor mounted starter type switch located between the left and right turn signal switches and raised away from the same plan as the Turn Signal Switches.**
- (c) **A minimum of six 15cm (6 inch) ceiling mounted speakers required.**
- (d) **P.A. system shall consist of an R.E.I. amplifier model #70092, or approved equivalent, Mobilpage microphone #MAC 565 on an Atlas Sound gooseneck assembly #AD11 with 68.58cm (27 inch) overall length mounted in the left front upper corner of the operator's compartment.**
- (e) **Portable P.A. jack must be installed behind the operator's seat operated with separate switch on operator's console.**

E2.285 Referencing APTA Guideline TS 86.2.1 Speakers:

- (a) **Six interior loudspeakers shall be provided, semi-flush mounted, on alternate sides of the bus passenger compartment, installed with proper phasing. One exterior loud speaker over top of front door. Total impedance seen at the input connecting end shall be 8 Ohms. Mounting shall be accomplished with riv-nuts and machine screws.**

E2.286 Referencing APTA Guideline TS 86.3 Automatic Passenger Counter (APC):

- (a) **An APC wiring harness (shielded wires) shall be installed by the Contractor to accommodate the APC system. APC location details to be provided by the City.**
- (b) **The wiring harness and equipment installation shall be as follows:**
 - (i) **One 4 wire and one 2 wire shielded/stranded 22 gauge wire harness to run from the Exit door to the APC computer mount provision. Wire must be ECI Electrocom FT-4 LL61365DR or approved equal;**
 - (ii) **One 4 wire and one 2 wire shielded/stranded 22 gauge wire harness from the Entrance door compartment to the APC computer mount provision. Wire must be ECI Electrocom FT- 4LL61365DR or approved equal;**
 - (iii) **One 4 wire shielded/stranded 22 gauge wire harness from the Side Sign to the APC computer mount. Wire must be ECI Electrocom FT – 4LL61365DR or approved equal;**
 - (iv) **One 16 gauge wire from the dash speedometer to the APC computer mount;**
 - (v) **One 16 gauge wire from the ramp control signal source to the APC computer mount;**
 - (vi) **One 2 wire 14 gauge harness terminating at the APC computer mount – one wire to be 12 volt ignition source and one wire to be 12 volt battery source;**
 - (vii) **One – 15.24cm X 22.86cm (6 inch X 9 inch) metal mount plate located in an enclosure to allow for APC computer mounting;**
 - (viii) **One - 10.16cm X 10.16cm (4 inch X 4 inch) metal ground mounting plate to allow for GPS Antenna mount must be mounted to structural frame away from steel frame members; and**
 - (ix) **Extra 60.96cm (24 inches) of wiring on all harnesses at termination points to allow for equipment installation.**
 - (x) **All mounting locations to be approved by the City prior to production.**

E2.287 Referencing APTA Guideline TS 83.6.1 Operators Speaker:

- (a) Each bus shall have a speaker, protruding no more than 1 inch, in the ceiling panel above the operator. This speaker shall be the same component used for the speakers in the passenger compartment. It shall have 8 Ohms of impedance.

E2.288 Referencing APTA Guideline TS 86.4.2 Handset:

- (a) The City will install a handset for operator use.

E2.289 Referencing APTA Guideline TS 86.4.3 Operator Display Unit (DDU):

- (a) The operator display unit shall be mounted to the underside of the sign box above and to the left of the operator. The sign box shall be structurally capable of supporting the DDU without vibration, etc.

E2.290 GPS Antenna:

- (a) Infordev WLAN/GPS combo antenna:
 - (i) GSM: 800-2700 MHz;
 - (ii) WLAN: 2400-2485 MHz; and
 - (iii) GPS: 1575342 +/- 2 MHz.

E2.291 UHF Antennae:

- (a) **PRAIRIE MOBILE COMMUNICATION Excaliber SRL321A low profile, shall be installed with a "P" connector and cable in an approved location by the City. Antenna frequency range to be 413 to 418 Hz. Radio antenna mount provision shall be a minimum 30.48cm X 30.48cm (12 inch x 12 inch) ground plate. The co-axial cable shall be RG58 with AMP-PL259 and 831AP connectors on antenna end and RFU-505 connector on radio end. The antenna coaxial lead-in and fish wire must run inside a protective plastic conduit from the roof antenna to the street side harness support. The excess coaxial cable and fish wire must be coiled inside the radio lock box. Minimum 6 inch coaxial cable coiled up at the antenna end. Radio Power Supply wiring shall be One (1) #6 red and one (1) # 6 black SXL type, wires must be continuous without splices or connectors between battery box and the radio lock box. These wires must be protected on both ends to prevent accidental shorting.**

E2.292 5 Channel LTE Antenna:

- (a) Must be cradlepoint model number AP-CCWWG-BQAS22222RP34WH available from Novatech. Specification are specific to Winnipeg Transit.

E2.293 WIFI (internal):

- (a) Air gain # ASCEUK00463. Wiring routed to and coiled up in the secured diagnostic compartment.

E2.294 Radio must be provided with a filtered 12V- 25 amp direct battery power supply. Radio power supply circuit must remain energized for 30 minutes after the vehicle has been shut off. Two additional (2) spare wires shall be supplied from the power source to the radio box.

E3. INSPECTIONS AND PERFORMANCE TESTS

REFERENCING APTA GUIDELINE QA 1 CONTRACTOR'S IN-PLANT QUALITY ASSURANCE REQUIREMENTS

E3.1 Referencing APTA Guideline QA 1.1.1 Organization Establishment:

- (a) The Contractor shall establish and maintain an effective in-plant quality assurance organization. It shall be a specifically defined organization and should be directly responsible to the Contractor's top management. **Copy of Manufacturers formal Quality Assurance Program shall be provided and reviewed by the City. An on-site visit shall be provided on request of the City.**

E3.2 Referencing APTA Guideline QA 1.1.2 Control:

- (a) The quality assurance organization shall exercise quality control over all phases of production, from initiation of design through manufacture and preparation for delivery. The organization shall also control the quality of supplied articles.

E3.3 Referencing APTA Guideline QA 1.1.3 Authority and Responsibility:

- (a) The quality assurance organization shall have the authority and responsibility for reliability, quality control, inspection planning, establishment of the quality control system, and acceptance/rejection of materials and manufactured articles in the production of the transit buses.

REFERENCING APTA GUIDELINE QA 1.2 QUALITY ASSURANCE ORGANIZATION FUNCTIONS

E3.4 Referencing APTA Guideline QA 1.2.1 Minimum Functions:

- (a) The quality assurance organization shall include the following minimum functions:
 - (i) Work instructions: The quality assurance organization shall verify inspection operation instructions to ascertain that the manufactured product meets all prescribed requirements.
 - (ii) Records maintenance: The quality assurance organization shall maintain and use records and data essential to the effective operation of its program. These records and data shall be available for review by the resident inspectors. Inspection and test records for this procurement shall be available for a minimum of one year after inspections and tests are completed.
 - (iii) Corrective action: The quality assurance organization shall detect and promptly ensure correction of any conditions that may result in the production of defective transit buses. These conditions may occur in designs, purchases, manufacture, tests or operations that culminate in defective supplies, services, facilities, technical data or standards.

E3.5 Referencing APTA Guideline QA 1.2.2 Basic Standards and Facilities:

- (a) The following standards and facilities shall be basic in the quality assurance process:
 - (i) Configuration control: The Contractor shall maintain drawings, assembly procedures, and other documentation that completely describe a qualified bus that meets all of the options and special requirements of this procurement. The quality assurance organization shall verify that each transit bus is manufactured in accordance with these controlled drawings, procedures, and documentation.
 - (ii) Measuring and testing facilities: The Contractor shall provide and maintain the necessary gauges and other measuring and testing devices for use by the quality assurance organization to verify that the buses conform to all specification requirements. These devices shall be calibrated at established periods against certified measurement standards that have known, valid relationships to national standards.
 - (iii) Production tooling as media of inspection: When production jigs, fixtures, tooling masters, templates, patterns, and other devices are used as media of inspection, they shall be proved for accuracy at formally established intervals and adjusted, replaced, or repaired as required to maintain quality.
 - (iv) Equipment use by resident inspectors: The Contractor's gauges and other measuring and testing devices shall be made available for use by the resident inspectors to verify that the buses conform to all specification requirements. If necessary, the Contractor's personnel shall be made available to operate the devices and to verify their condition and accuracy.

E3.6 Referencing APTA Guideline QA 1.2.3 Maintenance of Control:

- (a) The Contractor shall maintain quality control of purchases:
 - (i) Supplier control: The Contractor shall require that each Supplier maintains a quality control program for the services and supplies that it provides. The Contractor's quality assurance organization shall inspect and test materials provided by Suppliers for conformance to specification requirements. Materials that have been inspected, tested, and approved shall be identified as acceptable to the point of use in the manufacturing or assembly processes. Controls shall be established to prevent inadvertent use of nonconforming materials.
 - (ii) Purchasing data: The Contractor shall verify that all applicable specification requirements are properly included or referenced in purchase orders of articles to be used on transit buses.

E3.7 Referencing APTA Guideline QA 1.2.4 Manufacturing Control:

- (a) Controlled conditions: The Contractor shall ensure that all basic production operations, as well as all other processing and fabricating, are performed under controlled conditions. Establishment of these controlled conditions shall be based on the documented Work instructions, adequate production equipment and special working environments if necessary.
- (b) Completed items: A system for final inspection and test of completed transit buses shall be provided by the quality assurance organization. It shall measure the overall quality of each completed bus.
- (c) Nonconforming materials: The quality assurance organization shall monitor the Contractor's system for controlling nonconforming materials. The system shall include procedures for identification, segregation and disposition.
- (d) Statistical techniques: Statistical analysis, tests and other quality control procedures may be used when appropriate in the quality assurance processes.
- (e) Inspection status: A system shall be maintained by the quality assurance organization for identifying the inspection status of components and completed transit buses. Identification may include cards, tags or other normal quality control devices.

E3.8 Referencing APTA Guideline QA 1.2.5 Inspection System:

- (a) The quality assurance organization shall establish, maintain and periodically audit a fully documented inspection system. The system shall prescribe inspection and test of materials, Work in process and completed articles. As a minimum, it shall include the following controls:
 - (i) Inspection personnel: Sufficient trained inspectors shall be used to ensure that all materials, components and assemblies are inspected for conformance with the qualified bus design.
 - (ii) Inspection records: Acceptance, rework or rejection identification shall be attached to inspected articles. Articles that have been accepted as a result of approved materials review actions shall be identified. Articles that have been reworked to specified drawing configurations shall not require special identification. Articles rejected as unsuitable or scrap shall be plainly marked and controlled to prevent installation on the bus. Articles that become obsolete as a result of engineering changes or other actions shall be controlled to prevent unauthorized assembly or installation. Unusable articles shall be isolated and then scrapped. Discrepancies noted by the Contractor or resident inspectors during assembly shall be entered by the inspection personnel on a record that accompanies the major component, subassembly, assembly, or bus from start of assembly through final inspection. Actions shall be taken to correct discrepancies or deficiencies in the manufacturing processes, procedures or other conditions that cause articles to be in nonconformity with the requirements of the Contract specifications. The inspection personnel shall verify the corrective actions and mark the discrepancy record. If discrepancies cannot be corrected by replacing the nonconforming materials, then the City shall

approve the modification, repair or method of correction to the extent that the Contract specifications are affected.

- (iii) Quality assurance audits: The quality assurance organization shall establish and maintain a quality control audit program. Records of this program shall be subject to review by the City.

E3.9 Referencing APTA Guideline QA 2.1 Inspection Stations:

- (a) Inspection stations shall be at the best locations to provide for the Work content and characteristics to be inspected. Stations shall provide the facilities and equipment to inspect structural, electrical, hydraulic and other components and assemblies for compliance with the design requirements.
- (b) Stations shall also be at the best locations to inspect or test characteristics before they are concealed by subsequent fabrication or assembly operations. These locations shall minimally include underbody structure completion, body framing completion, body prior to paint preparation, water test, engine installation completion, underbody dress-up and completion, bus prior to final paint touch-up, bus prior to road test and bus final road test completion.

E3.10 Referencing APTA Guideline QA 2.2.1 Resident Inspector's Role:

- (a) The City shall be represented at the Contractor's plant by resident inspectors. Resident inspectors may be City employees or outside contractors. The City shall provide the identity of each inspector and shall also identify their level of authority in writing. They shall monitor, in the Contractor's plant, the manufacture of transit buses built under the procurement. The presence of these resident inspectors in the plant shall not relieve the Contractor of its responsibility to meet all of the requirements of this procurement. The City shall designate a primary resident inspector, whose duties and responsibilities are delineated in "Pre-Production Meetings," "Authority," and "Pre-Delivery Tests," below.

E3.11 Referencing APTA Guideline QA 2.2.2 Pre-Production Meetings:

- (a) The primary resident inspector may participate in design review and pre-production meetings with the City. At these meetings, the configuration of the buses and the manufacturing processes shall be finalized, and all Contract documentation provided to the inspector.
- (b) No less than thirty (30) Calendar Days prior to the beginning of bus manufacture, the primary resident inspector may meet with the Contractor's quality assurance manager and may conduct a pre- production audit meeting. They shall review the inspection procedures and finalize inspection checklists. The resident inspectors may begin monitoring bus construction activities two weeks prior to the start of bus fabrication.

E3.12 Referencing APTA Guideline QA 2.2.3 Authority:

- (a) Records and data maintained by the quality assurance organization shall be available for review by the resident inspectors. Inspection and test records for this procurement shall be available for a minimum of one year after inspections and tests are completed.
- (b) The Contractor's gauges and other measuring and testing devices shall be made available for use by the resident inspectors to verify that the buses conform to all specification requirements. If necessary, the Contractor's personnel shall be made available to operate the devices and to verify their condition and accuracy.
- (c) Discrepancies noted by the resident inspector during assembly shall be entered by the Contractor's inspection personnel on a record that accompanies the major component, subassembly, assembly or bus from start of assembly through final inspection. Actions shall be taken to correct discrepancies or deficiencies in the manufacturing processes, procedures or other conditions that cause articles to be in nonconformity with the requirements of the Contract specifications. The inspection personnel shall verify the corrective actions and mark the discrepancy record. If discrepancies cannot be corrected by replacing the nonconforming materials, the City shall approve the modification, repair or method of correction to the extent that the Contract specifications are affected.

- (d) The primary resident inspector may remain in the Contractor's plant for the duration of bus assembly Work under this Contract, at the discretion of the City. Only the primary resident inspector or designee shall be authorized to release the buses for delivery. The resident inspectors shall be authorized to approve the pre-delivery acceptance tests. Upon request to the quality assurance supervisors, the resident inspectors shall have access to the Contractor's quality assurance files related to this procurement. These files shall include drawings, assembly procedures, material standards, parts lists, inspection processing and reports, and records of Defects.

E3.13 Referencing APTA Guideline QA 2.2.4 Support Provisions:

- (a) The Contractor shall provide an enclosed office space for the resident inspectors in close proximity to the final assembly area. This **enclosed** office space shall be equipped with desks, outside and interplant telephones, Internet access (Wifi), file cabinet and chairs.

E3.14 Referencing APTA Guideline QA 2.2.5 Compliance with Safety Requirements:

- (a) At the time of the Pre-Production meeting, the Contractor shall provide all safety and other operational restrictions that govern the Contractor's facilities. These issues will be discussed and the parties will agree which rules/restrictions will govern the City's inspector(s) and any other City representatives during the course of the Contract.

REFERENCING APTA GUIDELINE QA 3 ACCEPTANCE TESTS

E3.15 Referencing APTA Guideline QA 3.1 Responsibility:

- (a) Fully documented tests shall be conducted on each production bus following manufacture to determine its acceptance to the City. These acceptance tests shall include pre-delivery inspections and testing by the Contractor and inspections and testing by the City after the buses have been delivered.

E3.16 Referencing APTA Guideline QA 3.2 Pre-Delivery Tests:

- (a) The Contractor shall conduct acceptance tests at its plant on each bus following completion of manufacture and before delivery to the City. These pre-delivery tests shall include visual and measured inspections, as well as testing the total bus operation. The tests shall be conducted and documented in accordance with written test plans approved by the City.
- (b) Additional tests may be conducted at the Contractor's discretion to ensure that the completed buses have attained the required quality and have met the requirements in E2. The City may, prior to commencement of production, demand that the Contractor demonstrate compliance with any requirement in that section if there is evidence that prior tests have been invalidated by the Contractor's change of Supplier or change in manufacturing process. Such demonstration shall be by actual test or by supplying a report of a previously performed test on similar or like components and configuration. Any additional testing shall be recorded on appropriate test forms provided by the Contractor and shall be conducted before acceptance of the bus.
- (c) The pre-delivery tests shall be scheduled and conducted with thirty (30) Calendar Days' notice so that they may be witnessed by the resident inspectors, who may accept or reject the results of the tests. The results of pre-delivery tests, and any other tests, shall be filed with the assembly inspection records for each bus. The underfloor equipment shall be available for inspection by the resident inspectors, using a pit or bus hoist provided by the Contractor. A hoist, scaffold or elevated platform shall be provided by the Contractor to easily and safely inspect bus roofs. Delivery of each bus shall require written authorization of the primary resident inspector. Authorization forms for the release of each bus for delivery shall be provided by the Contractor. An executed copy of the authorization shall accompany the delivery of each bus.

E3.17 Referencing APTA Guideline QA 3.2.1 Visual and Measured Inspections:

- (a) Visual and measured inspections shall be conducted with the bus in a static condition. The purpose of the inspection testing includes verification of overall dimension and weight requirements, that required components are included and are ready for operation, and that components and subsystems designed to operate with the bus in a static condition do function as designed.

E3.18 Referencing APTA Guideline QA 3.2.2 Total Bus Operation:

- (a) Total bus operation shall be evaluated during road tests. The purpose of the road tests is to observe and verify the operation of the bus as a system and to verify the functional operation of the subsystems that can be operated only while the bus is in motion.
- (b) Each bus shall be driven for a minimum of twenty-five (25) kilometres during the road tests. If requested, computerized diagnostic printouts showing the performance of each bus shall be produced and provided to the City. Observed Defects shall be recorded on the test forms. The bus shall be retested when Defects are corrected and adjustments are made. This process shall continue until Defects or required adjustments are no longer detected.

REFERENCING APTA GUIDELINE ATTACHMENT A: NEW BUS MANUFACTURING INSPECTION GUIDELINES

E3.19 Pre-production meeting Responsibilities:

- (a) Agency:
 - (i) Provides conformed copy of technical requirements.
- (b) Recommended staff to be involved may include the following:
 - (i) Project manager;
 - (ii) Technical engineer;
 - (iii) Contract administrator;
 - (iv) Quality assurance administrator; and
 - (v) Warranty administrator.
- (c) Process for inspector's role (to deal with Agency) for negotiated changes after freeze date.
- (d) Contractual requirements:
 - (i) Milestones;
 - (ii) Documentation ;
 - (iii) Title requirements;
 - (iv) Deliverables;
 - (v) Payments; and
 - (vi) Reliability tracking.
- (e) Manufacturer identifies any open issues.
- (f) Recommended staff to be involved may include the following:
 - (i) Project manager;
 - (ii) Technical engineer(s) ;
 - (iii) Contract administrator; and
 - (iv) Quality assurance administrator.
- (g) Warranty administrator:
 - (i) Production flow (buses/week, shifts).
 - (ii) Delivery schedule and offsite component build-up schedule.
 - (iii) Bus QA documentation (including supplier application approvals and/or any certifications required for the specific production).
 - (iv) Communication flow/decision making.

- (h) Inspector:
 - (i) Agree on decisions inspectors can and cannot make;
 - (ii) Primary contact for problems;
 - (iii) Production flow process (description of manufacturing by station);
 - (iv) Factory hours (manage inspection schedule based on production hours);
 - (v) Plant rules;
 - (vi) Safety requirements;
 - (vii) Orientation requirements;
 - (viii) Work environment; and
 - (ix) Inspector's office space (per contract).
- (i) As a result of this meeting, documentation should be produced detailing final production requirements and the planned configuration of the bus.

E3.20 Build schedule:

- (a) The bus manufacturer's contract administrator shall supply a fleet build production schedule based on the dates in the Notice to Proceed, and a description of the manufacturer's schedule for plant operations.
- (b) The production schedule should contain specific milestone dates, such as:
 - (i) First vehicle on production line (date on which any work will begin);
 - (ii) First vehicle off production line;
 - (iii) First vehicle through manufacturer's quality assurance inspections;
 - (iv) First vehicle shipped to the City;
 - (v) Last vehicle on production line;
 - (vi) Last vehicle off production line; and
 - (vii) Last vehicle shipped to the City.

E3.21 Plant tour:

- (a) The City will review the entire process from start to finish and review the work completed at each line station, including quality control measures.

E3.22 Prototype/pilot vehicle production:

- (a) The contractor shall conduct acceptance tests at its plant on each bus following completion of manufacture and before delivery to the City. These pre-delivery tests shall include visual and measured inspections, as well as testing the total bus operation. The tests shall be conducted and documented in accordance with written test plans approved by the City. The underfloor equipment shall be available for inspection by the resident inspectors, using a pit or bus hoist provided by the contractor. A hoist, scaffold or elevated platform shall be provided by the contractor to easily and safely inspect bus roofs. Delivery of each bus shall require written authorization of the primary resident inspector. Authorization forms for the release of each bus for delivery shall be provided by the contractor. An executed copy of the authorization shall accompany the delivery of each bus.
- (b) Additional tests may be conducted at the City's discretion to ensure that the completed buses have attained the required quality and have met the requirements in the APTA "Standard Bus Procurement Guidelines RFP," Section 6: Technical Specifications. The City may, prior to commencement of production, demand that the contractor demonstrate compliance with any requirement in that section if there is evidence that prior tests have been invalidated by the contractor's change of supplier or change in manufacturing process. Such demonstration shall be by actual test or by supplying a report of a previously performed test on similar or like components and configuration. Any additional testing shall be recorded on appropriate test forms provided by the contractor and shall be conducted before acceptance of the bus.

- (c) The pre-delivery tests shall be scheduled and conducted with 30 Calendar Days' notice so that they may be witnessed by the resident inspectors, who may accept or reject the results of the tests. The results of pre-delivery tests, and any other tests, shall be filed with the assembly inspection records for each bus.

E3.23 Visual and measured inspections:

- (a) Visual and measured inspections shall be conducted with the bus in a static condition. The purpose of the inspection testing includes verification of overall dimension and weight requirements, that required components are included and are ready for operation, and that components and subsystems designed to operate with the bus in a static condition do function as designed.

E3.24 Total bus operation:

- (a) Total bus operation shall be evaluated during road tests. The purpose of the road tests is to observe and verify the operation of the bus as a system and to verify the functional operation of the subsystems that can be operated only while the bus is in motion.
- (b) Each bus shall be driven for a minimum of 25 kilometres during the road tests. If requested, computerized diagnostic printouts showing the performance of each bus shall be produced and provided to the City. Observed defects shall be recorded on the test forms. The bus shall be retested when defects are corrected and adjustments are made. This process shall continue until defects or required adjustments are no longer detected.

E3.25 Post-delivery tests:

- (a) The City shall conduct acceptance tests on each delivered bus. These tests shall be completed within 15 Business Days after bus delivery and shall be conducted in accordance with the City's written test plans. The purpose of these tests is to identify defects that have become apparent between the time of bus release and delivery to the City. The post-delivery tests shall include visual inspection and bus operations. No post-delivery test shall apply new criteria that are different from criteria applied in a pre-delivery test.
- (b) Buses that fail to pass the post-delivery tests are subject to non-acceptance. The City shall record details of all defects on the appropriate test forms and shall notify the contractor of acceptance or non-acceptance of each bus, after completion of the tests. The defects detected during these tests shall be repaired according to procedures defined in the contract.

E3.26 Prototype/pilot vehicle acceptance:

- (a) In order to assess the contractor's compliance with the Technical Specifications, the City and the contractor shall, at the pre-production meeting, jointly develop a Configuration and Performance Review document for review of the pilot vehicle. This document shall become part of the official record of the pre-production meeting.
- (b) Potential dimensional/performance tests that may be included in the Configuration and Performance Review include the following:
 - (i) Complete electrical system audit;
 - (ii) Dimensional requirements audit;
 - (iii) Seating capacity;
 - (iv) Water test;
 - (v) Water runoff test;
 - (vi) Function test of systems/subsystems and components;
 - (vii) Sound/noise level tests;
 - (viii) Vehicle top speed;
 - (ix) Acceleration tests;
 - (x) Brake stop tests;
 - (xi) Airflow tests;

- (xii) PA function tests;
 - (xiii) Air/brake system audit;
 - (xiv) Individual axle weight;
 - (xv) Standee capacity;
 - (xvi) Body deflection tests;
 - (xvii) Silent alarm function test;
 - (xviii) Interior lighting;
 - (xix) Exterior lighting;
 - (xx) Gradability test;
 - (xxi) Kneeling system function;
 - (xxii) HVAC pulldown/heat;
 - (xxiii) Speedometer;
 - (xxiv) Outside air infiltration (smoke);
 - (xxv) Wheelchair ramps; and
 - (xxvi) Engine performance qualification.
- (c) This test shall be jointly conducted by the contractor and engine manufacturer (including but not limited to charge air cooler performance, air to boil test, loss of coolant, fuel system electrical inputs and engine protection system).
- (i) Transmission performance qualifications.
- (d) This test shall be jointly conducted by the Contractor and transmission manufacturer (including but not limited to retarder operation, heat exchanger, interface with ABS and electrical inputs).

E3.27 Resident inspection process for serial production:

- (a) At the discretion of the City, a decision is made to perform resident inspection using the City's personnel, a contract inspector, or a combination of both. The decision is based on factors such as the availability of personnel, knowledge/expertise in bus build project management, the size of the bus order, etc.

E3.28 Inspector responsibilities:

- (a) The resident inspection process for the serial production of the buses begins following the completion and acceptance of the prototype or pilot vehicle if required, or according to the serial bus production schedule. Resident inspectors should represent the City for all build-related issues (quality, conformance, etc.). Resident inspectors can also address contractual type issues but should only do so under the consult of the City's contracts administrator. Resident inspectors are sent to the manufacturer's facility according to a Resident Inspection Schedule. Typically, one or two inspectors arrive on site at the manufacturing facility about one week prior to actual production to set up the resident inspection process and to begin preliminary quality assurance inspections for items such as power plant build-up and wire harness production, and to inspect incoming parts, fasteners, fluids, etc., that will be used in the production of the buses. During the serial production of the buses, the resident inspectors should monitor the production of each bus, verifying the quality of materials, components, sub- assemblies and manufacturing standards. In addition, the configuration of each vehicle should be audited using the vehicle manufacturer's Build Specification and other documents to ensure contract compliance and uniformity.
- (b) **City of Winnipeg inspectors must have unrestricted access to inspect the materials and processes used on its vehicles at the Contractor's manufacturing facility at all stages of production.**

E3.29 Inspector rotation/scheduling:

- (a) During all inspection phases, a single inspector or multiple inspectors could be used. If it is decided to use multiple inspectors, then the inspectors could be rotated on a biweekly basis.
- (b) **Bidders with facilities located outside the City of Winnipeg must include in their bids and shall bear all costs for two inspectors to spend a minimum five (5) full Business Days per week that buses are in production at their manufacturing facility on a weekly basis. Costs must include air and/or vehicle transportation between Winnipeg and the manufacturing facility. Costs must include lodging and be approved by the City, and additional vehicle transportation between the hotel and the manufacturing facility, (vehicle type supplied will be determined by the time of year and weather conditions) and shall include all applicable insurances. Costs of per diem rate per day per person as set by the City of Winnipeg for meals and other costs. Out of Province medical insurance must be provided in the form of a sub-contractor supply such as Blue Cross Extended Travel Insurance for the time period that the Inspectors are out of Province.**
- (c) **All overtime salary costs of City employees incurred during all phases of inspection at the request of the Contractor shall be borne by the Contractor.**

E3.30 Resident inspector orientation:

- (a) A resident inspector orientation by the bus manufacturer should take place upon the arrival of the initial inspection team. The orientation should include expectations for the use of personal protective equipment (safety shoes, safety glasses, etc.), daily check-in and check-out requirements, lines of communication, use of production documents such as speed memos and line movement charts, inspector/production meetings, inspector office **(with door)** arrangements, and anything else pertinent to the inspection team's involvement during the build. Many of the above items should already be formalized during the pre-production meeting.

E3.31 Audits, inspections and tests:

- (a) The resident inspection process monitors the production of each vehicle. Inspection stations should be strategically placed to test or inspect components or other installations before they are concealed by subsequent fabrication or assembly operations. These locations typically are placed for the inspection of underbody structure, body framing, electrical panels and harnesses, air and hydraulic line routings, installation of insulation, power plant build-up and installation, rust inhibitor/undercoating application, floor installation, front suspension alignment, and other critical areas.

E3.32 Vehicle inspections:

- (a) Each bus is subjected to a series of inspections after the bus reaches the point of final completion on the assembly line. Typically, the vehicle manufacturer performs its own quality assurance inspections following assembly line completion before releasing each bus to the resident inspectors. The inspections for each vehicle are documented, signed off upon passing and included in the vehicle record.
- (b) These are the typical inspections performed on each bus by the resident inspectors:
 - (i) Water test inspection;
 - (ii) Road test inspection;
 - (iii) Interior inspection (including functionality);
 - (iv) Hoist/undercarriage inspection;
 - (v) Exterior inspection (including roof);
 - (vi) Electrical inspection including torque ;
 - (vii) Engine; and
 - (viii) Wheelchair ramp/lift inspection.

E3.33 Water test inspection:

- (a) The **10 minute minimal** water test inspection checks the integrity of the vehicle's body seams, window frame seals and other exterior component close-outs for their ability to keep rainwater, road splash, melting snow and slush, and other exterior water from entering the inside of the vehicle. The test shall be conducted in a purpose-built water test booth. The vehicle's interior is inspected for signs of moisture and water leaks. To perform the leak inspection, interior ceiling and side panels are removed, and access doors are opened. If any moisture or water is detected, then the source of the leak will be located and repaired by the manufacturer, and the vehicle will be tested again – **10 minutes for each retest.**

E3.34 Road test inspection:

- (a) The road test inspection checks all the vehicle's systems and sub-systems while the vehicle is in operation. Typically, the road test inspection is performed immediately following the water test inspection to reveal any standing water that may be present due to a leak, but was not noticed during the "static" water test. Objectionable vibrations, air leakage and other factors that affect ride quality are recorded and reported to the vehicle manufacturer for resolution. Vehicle stability, performance, braking and interlock systems, HVAC, and other critical areas are checked to ensure that the vehicle is complete and ready to provide safe and reliable service.
- (b) The following tests may be performed and recorded during the road test:
 - (i) Acceleration test;
 - (ii) Top speed test;
 - (iii) Gradability test;
 - (iv) Service brake test;
 - (v) Parking brake test;
 - (vi) Turning effort test;
 - (vii) Turning radius test;
 - (viii) Shift quality; and
 - (ix) Quality of retarder or regenerative braking action.
- (c) Midway check:
 - (i) Engine temperature;
 - (ii) Oil pressure;
 - (iii) Leaks;
 - (iv) Coolant system; and
 - (v) Fuel leaks.
- (d) During the road test, a vehicle may be taken to a weigh station to record the vehicle's front axle weight; rear axle weight and total vehicle (curb) weight.

E3.35 Interior inspection:

- (a) The interior inspection checks the fit and finish of the interior installations.
- (b) In addition, the inspection also verifies the installation and function of systems and subsystems according to the Build Specification. All systems and functions accessed from the interior are inspected for functionality, appearance and safety.
- (c) Examples of systems/functions inspected include the following:
 - (i) Interior and exterior lighting controls;
 - (ii) Front and rear door systems;
 - (iii) Flooring installation;
 - (iv) Passenger and operator's seat systems;

- (v) Wheelchair securement and ramp systems;
- (vi) Fire suppression system;
- (vii) Electrical installations (multiplex, tell-tale wiring, panels, etc.);
- (viii) Window systems and emergency escape portals; and
- (ix) Operator dash/side panel controls/indicators.

E3.36 Hoist/undercarriage inspection:

- (a) The hoist/undercarriage inspection checks the installation of components, wiring, air lines, presence of fluid leaks, etc., located under the vehicle. Typically, this inspection is performed following the road test. The vehicle is lifted onto a hoist or pulled over a pit for the inspection. Areas inspected are the front suspension, air bags, airline routings, electrical connections and routings, drive-train components, linkages, and any other system or component that may be prone to early failure due to inadequate installation techniques. All lines, cables, hoses, etc., are inspected for proper securement and protection to prevent rubbing, chafing or any other condition that could result in a failure. The engine/powerplant and HVAC compartments are also inspected during this time.

E3.37 Exterior inspection:

- (a) The exterior inspection checks the fit and finish of components installed on the exterior of the vehicle. Access panels are opened and accessories are inspected for proper installation. In addition, vehicle paint, graphics and proper decals are also inspected. Acceptable paint finish quality (orange peel, adhesion, etc.) should be agreed on with the vehicle manufacturer prior to production to ensure consistency of inspections.

E3.38 Electrical inspection:

- (a) The vehicle's main electrical panels and other sub-panels are inspected for proper components, to include relays, fuses, modules, terminal strips, decals, etc. In addition, electrical harnesses are inspected for proper wiring and termination techniques, bulkhead protection, looming and other items that could result in future electrical failure. Onboard vehicle compartment schematics are verified for accuracy.

E3.39 Wheelchair ramp inspection:

- (a) The wheelchair ramp assembly is inspected for proper installation and performance. Clearances critical to the operation of the ramp are verified, and the ramp's electrical systems are inspected to ensure appropriate wire routings and protection. The successful integration of the ramp assembly into the vehicle is verified, and the vehicle interlocks are checked during automatic and manual ramp operation.

E3.40 Audits:

- (a) During serial production of the bus's quality assurance inspection, tests may be performed to ensure that the manufacturer's quality standards are being followed. These inspection audits could be on items such as torque wrench calibrations, proper techniques for fastener installations, proper use and type of adhesives, use of correct installation drawings on the production line, etc.

E3.41 Communications:

- (a) The lines of communications, formal and informal, should be discussed and outlined in the pre-production meeting. As previously discussed, resident inspectors should represent the City for all bus-build related issues (quality, conformance, etc.). Resident inspectors can relay communications addressing contractual type issues but should do so only under the consult of the City's contracts administrator or designate. Actual personnel contacts for the manufacturing facility should be established during resident inspector orientation. These contacts could include quality assurance, production, material handling, engineering, and buy-off area personnel.

E3.42 Documentation:

- (a) The following documents/reports are typically generated during the bus build process:
 - (i) Vehicle Build Specification;
 - (ii) Sales Order;
 - (iii) Pre-production meeting notes;
 - (iv) Prototype and production correspondence (vehicle build file); and
 - (v) Manufacturer's Vehicle Record (Warranty file).
- (b) Vehicle line documents;
- (c) Serialization documents (Warranty file);
- (d) Alignment verification;
- (e) Brake testing;
- (f) HVAC testing and checkout;
- (g) Manufacturer's QA checklist and signoff;
- (h) Weight Slip (Prototype & Warranty file);
- (i) Prototype Performance Tests document (vehicle build file):
 - (i) Acceleration Test;
 - (ii) Top Speed Test;
 - (iii) Gradability Test;
 - (iv) Interior Noise Test A – Stationary;
 - (v) Interior Noise Test B – Dynamic;
 - (vi) Exterior Noise Test A – Pull Away;
 - (vii) Exterior Noise Test B – Pass-By;
 - (viii) Exterior Noise Test C – Curb Idle;
 - (ix) Turning Radius Test;
 - (x) Turning Effort Test;
 - (xi) Parking Brake; and
 - (xii) Test Service Brake Test.
- (j) Vehicle Acceptance Inspections – Production (Warranty file):
 - (i) Water Test Inspection Report;
 - (ii) Road Test Inspection Report;
 - (iii) Interior Inspection Report;
 - (iv) Hoist/Undercarriage Inspection Report;
 - (v) Exterior Inspection Report;
 - (vi) Electrical Inspection Report; and
 - (vii) Wheelchair Inspection Report.
- (k) Speed Memos (Warranty file);
- (l) City Vehicle Inspection record (Warranty file);
- (m) Release for Delivery documentation (Warranty file);
- (n) Post-Production Acceptance – Certificate of Acceptance (Accounting); and
- (o) Post-Delivery Inspection Report – (Fleet Management & Warranty files).

E3.43 Vehicle release for delivery:

- (a) Final audit inspection shall be provided to accommodate Fixed Inspection Time of 6 hours, plus an average Variable Inspection Time of 3.5 minutes per documented deficiency, excluding downtime waiting for contractor inspectors, facilities, equipment, etc. identified at the First Final Audit Inspection, and subsequent Re-Inspections. Upon satisfactory completion of all inspection, audit and test criteria, and resolution (correction and repair) of any outstanding issues affecting the purchase of any or all buses, proper documentation (the Release for Delivery) is signed by the designated resident inspector authorizing the bus manufacturer to deliver the vehicle to the City's facility, where it will undergo a post-delivery inspection process and final acceptance. The satisfactory sign-off of the Release for Delivery should complete the resident inspector's duties for each bus. In final preparation for delivery, the bus manufacturer may request the resident inspector to do a final walk-through of the bus after it has been cleaned and prepped for shipping.

E3.44 Post-delivery and final acceptance:

- (a) The City shall conduct acceptance tests on each delivered bus. These tests shall be completed within 15 Calendar Days after bus delivery and shall be conducted in accordance with the City's written test plans. The purpose of these tests is to identify defects that have become apparent between the time of bus release and delivery to the City. The post-delivery tests shall include visual inspection, along with a verification of system(s) functionality and overall bus operations. No post-delivery test shall apply new criteria that are different from criteria applied in a pre-delivery test.
- (b) Buses that fail to pass the post-delivery tests are subject to non-acceptance. The City shall record details of all defects on the appropriate test forms and shall notify the contractor of acceptance or non-acceptance of each bus within five Business Days after completion of the tests. The defects detected during these tests shall be repaired according to procedures defined in the contract after non-acceptance.

E3.45 Certificate of Acceptance:

- (a) Accepted.
- (b) Not accepted: In the event that the bus does not meet all requirements for acceptance. The City must identify reasons for non-acceptance and work with the OEM to develop a timeline of addressing the problem for a satisfactory resolution and redelivery.
- (c) Conditional acceptance: In the event that the bus does not meet all requirements for acceptance, the City may conditionally accept the bus and place it into revenue service pending receipt of contractor furnished materials and/or labor necessary to address the identified issue(s).