

New Parapet

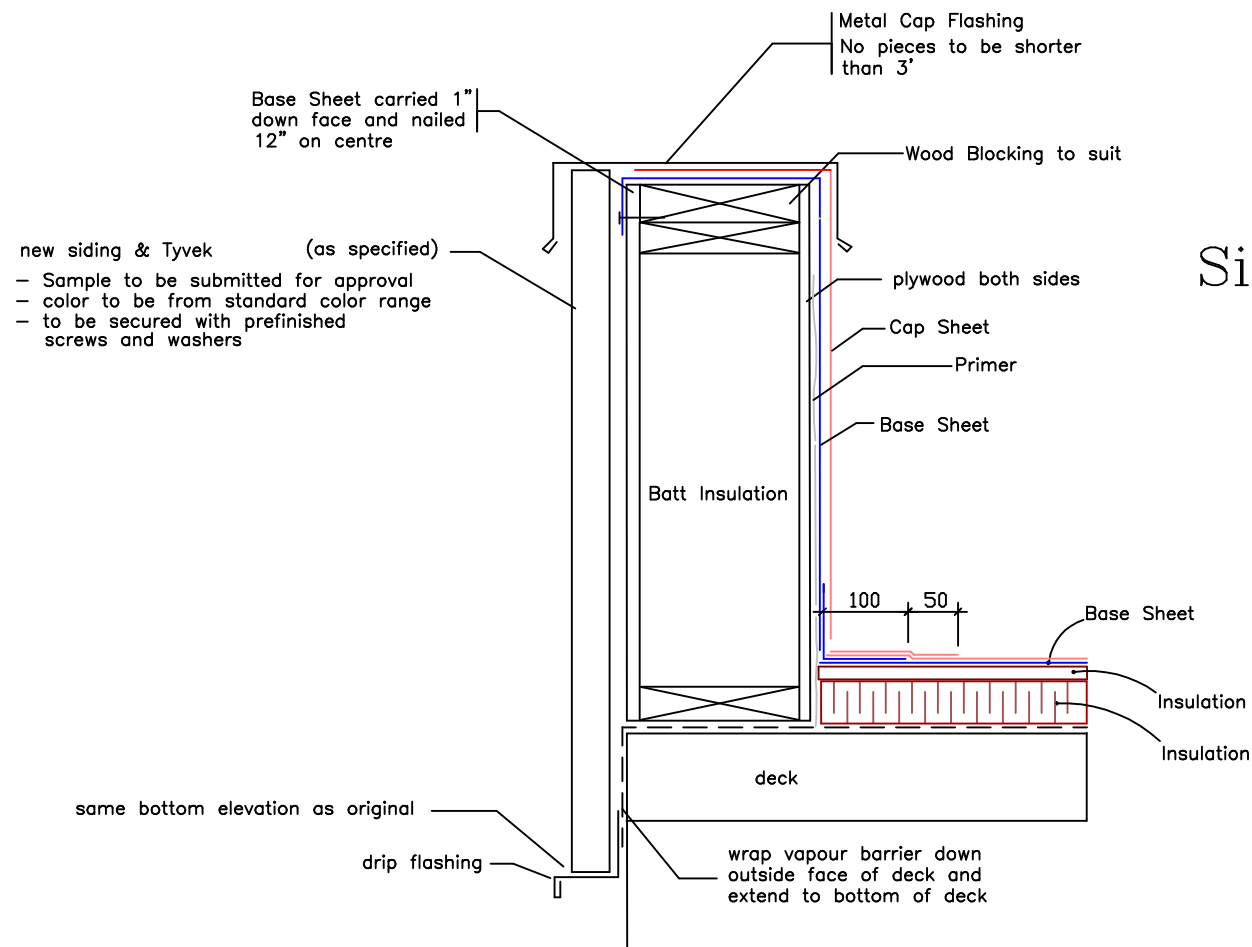

Siding Bottom Flashing

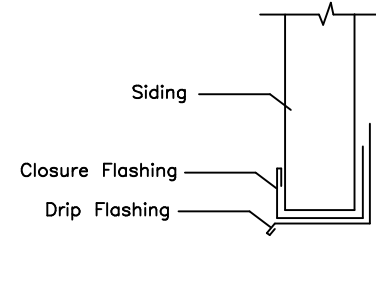

Plumbing Vent Flashing

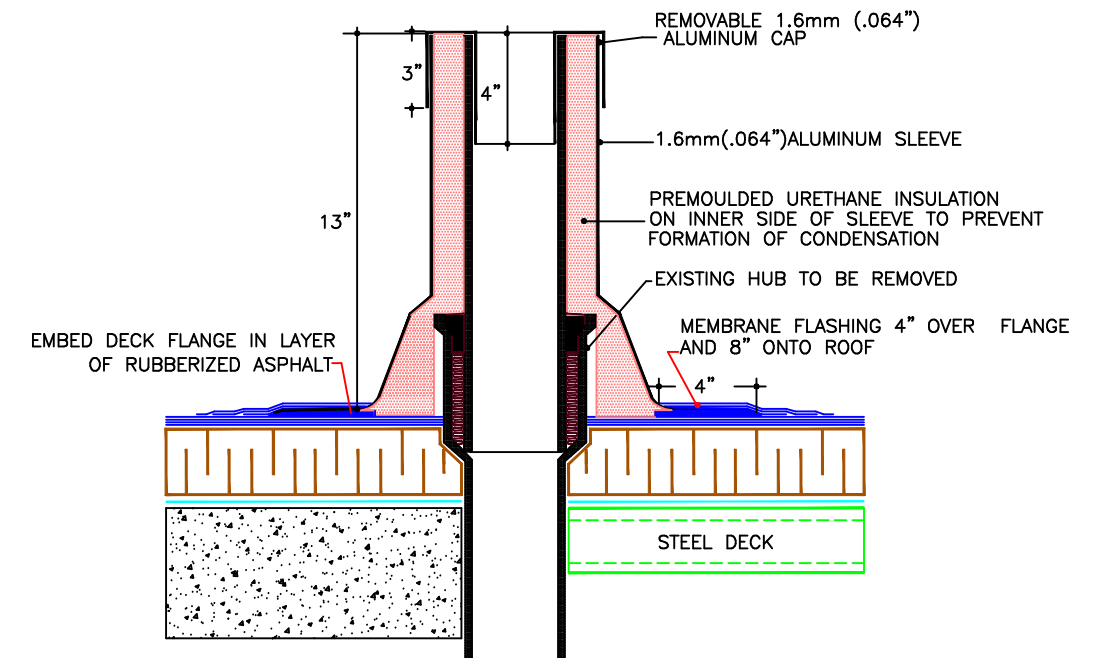

SJ-20 ALUMINUM STACK JACK (13") HIGH
 This is for illustrative purposes of installation only. Vandal proof flashings are to be installed.

Divider Flashing

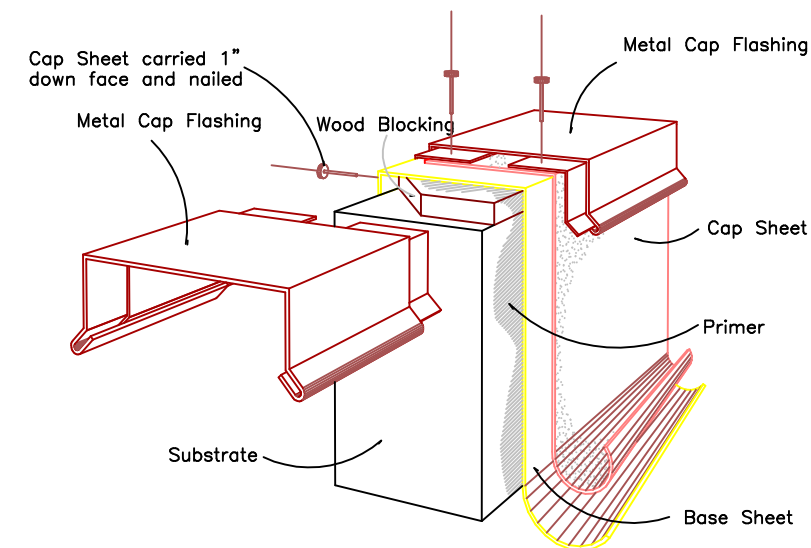

A continuous 18 gauge galvanized cleat is to be installed to insure outside face of flashing is firmly attached to outside face whenever outside face of flashing exceeds 4".

 Agassiz Consulting Group Ltd. Box 41, Warren, Manitoba R0C 3E0 Office Phone: (204) 383-5538	
Project:	St. John's Leisure Center 601 Alkins Winnipeg, MB
Date:	June 1, 2020
Drawing No.	D-1
File no:	4301-20
Scale:	1:100