



**THE CITY OF WINNIPEG**

**TENDER**

**TENDER NO. 618-2020**

**2021 LOCAL STREETS RENEWAL PROGRAM 21-R-05: DOWKER AVENUE AND  
VARIOUS OTHER LOCATIONS**

## TABLE OF CONTENTS

### PART A - BID SUBMISSION

- Form A: Bid/Proposal
- Form B: Prices
- Form G1: Bid Bond and Agreement to Bond

### PART B - BIDDING PROCEDURES

B1. Contract Title	1
B2. Submission Deadline	1
B3. Enquiries	1
B4. Confidentiality	1
B5. Addenda	1
B6. Substitutes	2
B7. Bid Components	3
B8. Bid	3
B9. Prices	4
B10. Disclosure	4
B11. Conflict of Interest and Good Faith	4
B12. Qualification	5
B13. Bid Security	6
B14. Opening of Bids and Release of Information	7
B15. Irrevocable Bid	7
B16. Withdrawal of Bids	8
B17. Evaluation of Bids	8
B18. Award of Contract	9

### PART C - GENERAL CONDITIONS

C0. General Conditions	1
------------------------	---

### PART D - SUPPLEMENTAL CONDITIONS

#### General

D1. General Conditions	1
D2. Form of Contract Documents	1
D3. Scope of Work	1
D4. Contract Administrator	3
D5. Contractor's Supervisor	3
D6. Notices	3
D7. Furnishing of Documents	4

#### Submissions

D8. Authority to Carry on Business	4
D9. Safe Work Plan	4
D10. Insurance	4
D11. Contract Security	5
D12. Subcontractor List	6
D13. Equipment List	6
D14. Detailed Work Schedule	6

#### Schedule of Work

D15. Commencement	6
D16. Working Days	7
D17. Restricted Work Hours	7
D18. Work By Others	7
D19. Sequence of Work	8
D20. Substantial Performance	9
D21. Total Performance	9
D22. Liquidated Damages	9

D23. COVID-19 Schedule Delays	9
D24. Scheduled Maintenance	10
<b>Control of Work</b>	
D25. Job Meetings	10
D26. Prime Contractor – The Workplace Safety and Health Act (Manitoba)	11
D27. The Workplace Safety and Health Act (Manitoba) – Qualifications	11
<b>Measurement and Payment</b>	
D28. Payment	11
<b>Warranty</b>	
D29. Warranty	11
<b>Third Party Agreements</b>	
D30. Funding and/or Contribution Agreement Obligations	11
Form H1: Performance Bond	14
Form H2: Labour and Material Payment Bond	16
Form J: Subcontractor List	18
Form K: Equipment	20
Form L: Detailed Work Schedule	22

## **PART E - SPECIFICATIONS**

<b>General</b>	
E1. Applicable Specifications and Drawings	1
E2. Mobilization and Demobilization Payment	3
E3. Geotechnical Report	4
E4. Office Facilities	4
E5. Protection Of Existing Trees	4
E6. Traffic Control	5
E7. Traffic Management	6
E8. Refuse and Recycling Collection	7
E9. Pedestrian Safety	8
E10. Water Obtained From the City	8
E11. Surface Restorations	8
E12. Infrastructure Signs	9
E13. Supply and Installation of Pavement Repair Fabric	9
E14. Partial Depth Patching of Existing Joints	9
E15. Asphalt Patching of Miscellaneous Concrete	10
E16. Salt Tolerant Grass Seeding	11
E17. Supply and Install Watermain and Water Service Insulation	12
E18. Replace Manhole Benching	13
E19. Curb and Gutter Various Formats	13
E20. Construction of Barrier Curb for Asphalt Pavement	15
E21. Portland Cement Concrete Sidewalk with Block Outs for Indicator Surfaces	16
E22. Paving Stones for Indicator Surfaces	16
E23. Bidding Instructions for Limestone and/or Recycled Base Course and Sub-Base Materials	17
E24. Working Around Teraspan Fibre Optic Lines	19
E25. Operating Constraints for Work in Close Proximity to Critical Water Infrastructure	19
E26. Installation of Street Lighting and Associated Works	23

**Appendix 'A' - Geotechnical Report**

**Appendix 'B' - Manitoba Hydro Electrical Standards - 2019 Street Light Installations**

**Appendix 'C' - Safe Excavation Safety Watch Guidelines**

**Appendix 'D' - Gelcap Kit**

**Appendix 'E' - Electric Gas Locate**

**Appendix 'F' - Sample Job Plan**

**Appendix 'G' - Network Communications**

**Appendix 'H' - Pavement Repair Fabric**

## **PART B - BIDDING PROCEDURES**

### **B1. CONTRACT TITLE**

B1.1 2021 Local Streets Renewal Program 21-R-05: Dowker Avenue and Various other Locations

### **B2. SUBMISSION DEADLINE**

B2.1 The Submission Deadline is 12:00 noon Winnipeg time, March 12, 2021.

### **B3. ENQUIRIES**

B3.1 All enquiries shall be directed to the Contract Administrator identified in D4.1.

B3.2 If the Bidder finds errors, discrepancies or omissions in the Tender, or is unsure of the meaning or intent of any provision therein, the Bidder shall notify the Contract Administrator of the error, discrepancy or omission, or request a clarification as to the meaning or intent of the provision at least five (5) Business Days prior to the Submission Deadline.

B3.3 Responses to enquiries which, in the sole judgment of the Contract Administrator, require a correction to or a clarification of the Tender will be provided by the Contract Administrator to all Bidders by issuing an addendum.

B3.4 Responses to enquiries which, in the sole judgment of the Contract Administrator, do not require a correction to or a clarification of the Tender will be provided by the Contract Administrator only to the Bidder who made the enquiry.

B3.5 The Bidder shall not be entitled to rely on any response or interpretation received pursuant to B3 unless that response or interpretation is provided by the Contract Administrator in writing.

B3.6 Any enquiries concerning submitting through MERX should be addressed to:  
MERX Customer Support  
Phone: 1-800-964-6379  
Email: merx@merx.com

### **B4. CONFIDENTIALITY**

B4.1 Information provided to a Bidder by the City or acquired by a Bidder by way of further enquiries or through investigation is confidential. Such information shall not be used or disclosed in any way without the prior written authorization of the Contract Administrator. The use and disclosure of the confidential information shall not apply to information which:

- (a) was known to the Bidder before receipt hereof; or
- (b) becomes publicly known other than through the Bidder; or
- (c) is disclosed pursuant to the requirements of a governmental authority or judicial order.

B4.2 The Bidder shall not make any statement of fact or opinion regarding any aspect of the Tender to the media or any member of the public without the prior written authorization of the Contract Administrator.

### **B5. ADDENDA**

B5.1 The Contract Administrator may, at any time prior to the Submission Deadline, issue addenda correcting errors, discrepancies or omissions in the Tender, or clarifying the meaning or intent of any provision therein.

B5.2 The Contract Administrator will issue each addendum at least two (2) Business Days prior to the Submission Deadline, or provide at least two (2) Business Days by extending the Submission Deadline.

- B5.3 Addenda will be available on the MERX website at [www.merx.com](http://www.merx.com).
- B5.4 The Bidder is responsible for ensuring that he/she has received all addenda and is advised to check the MERX website for addenda regularly and shortly before the Submission Deadline, as may be amended by addendum.
- B5.5 The Bidder shall acknowledge receipt of each addendum in Paragraph 10 of Form A: Bid/Proposal. Failure to acknowledge receipt of an addendum may render a Bid non-responsive.
- B5.6 Notwithstanding B3, enquiries related to an Addendum may be directed to the Contract Administrator indicated in D4.

**B6. SUBSTITUTES**

- B6.1 The Work is based on the Plant, Materials and methods specified in the Tender.
- B6.2 Substitutions shall not be allowed unless application has been made to and prior approval has been granted by the Contract Administrator in writing.
- B6.3 Requests for approval of a substitute will not be considered unless received in writing by the Contract Administrator at least five (5) Business Days prior to the Submission Deadline.
- B6.4 The Bidder shall ensure that any and all requests for approval of a substitute:
- (a) provide sufficient information and details to enable the Contract Administrator to determine the acceptability of the Plant, Material or method as either an approved equal or alternative;
  - (b) identify any and all changes required in the applicable Work, and all changes to any other Work, which would become necessary to accommodate the substitute;
  - (c) identify any anticipated cost or time savings that may be associated with the substitute;
  - (d) certify that, in the case of a request for approval as an approved equal, the substitute will fully perform the functions called for by the general design, be of equal or superior substance to that specified, is suited to the same use and capable of performing the same function as that specified and can be incorporated into the Work, strictly in accordance with the proposed work schedule and the dates specified in the Supplemental Conditions for Substantial Performance and Total Performance; and
  - (e) certify that, in the case of a request for approval as an approved alternative, the substitute will adequately perform the functions called for by the general design, be similar in substance to that specified, is suited to the same use and capable of performing the same function as that specified and can be incorporated into the Work, strictly in accordance with the proposed work schedule and the dates specified in the Supplemental Conditions for Substantial Performance and Total Performance.
- B6.5 The Contract Administrator, after assessing the request for approval of a substitute, may in his/her sole discretion grant approval for the use of a substitute as an “approved equal” or as an “approved alternative”, or may refuse to grant approval of the substitute.
- B6.6 The Contract Administrator will provide a response in writing, at least two (2) Business Days prior to the Submission Deadline, to the Bidder who requested approval of the substitute.
- B6.6.1 The Contract Administrator will issue an Addendum, disclosing the approved materials, equipment, methods and products to all potential Bidders. The Bidder requesting and obtaining the approval of a substitute shall be responsible for disseminating information regarding the approval to any person or persons he/she wishes to inform.
- B6.7 If the Contract Administrator approves a substitute as an “approved equal”, any Bidder may use the approved equal in place of the specified item.

- B6.8 If the Contract Administrator approves a substitute as an “approved alternative”, any Bidder bidding that approved alternative may base his/her Total Bid Price upon the specified item but may also indicate an alternative price based upon the approved alternative. Such alternatives will be evaluated in accordance with B17.
- B6.9 No later claim by the Contractor for an addition to the Total Bid Price because of any other changes in the Work necessitated by the use of an approved equal or an approved alternative will be considered.

## **B7. BID COMPONENTS**

- B7.1 The Bid shall consist of the following components:
- (a) Form A: Bid;
  - (b) Form B: Prices; and
  - (c) Form G1: Bid Bond and Agreement to Bond.
- B7.2 All components of the Bid shall be fully completed or provided, and submitted by the Bidder no later than the Submission Deadline, with all required entries made clearly and completely.
- B7.3 The Bid shall be submitted electronically through MERX at [www.merx.com](http://www.merx.com).
- B7.3.1 Bids will **only** be accepted electronically through MERX.
- B7.4 Bidders are advised that inclusion of terms and conditions inconsistent with the Tender document, including the General Conditions, will be evaluated in accordance with B17.1(a).

## **B8. BID**

- B8.1 The Bidder shall complete Form A: Bid/Proposal, making all required entries.
- B8.2 Paragraph 2 of Form A: Bid/Proposal shall be completed in accordance with the following requirements:
- (a) if the Bidder is a sole proprietor carrying on business in his/her own name, his/her name shall be inserted;
  - (b) if the Bidder is a partnership, the full name of the partnership shall be inserted;
  - (c) if the Bidder is a corporation, the full name of the corporation shall be inserted; and
  - (d) if the Bidder is carrying on business under a name other than his/her own, the business name and the name of every partner or corporation who is the owner of such business name shall be inserted.
- B8.2.1 If a Bid is submitted jointly by two (2) or more persons, each and all such persons shall identify themselves in accordance with B8.2.
- B8.3 In Paragraph 3 of Form A: Bid/Proposal, the Bidder shall identify a contact person who is authorized to represent the Bidder for purposes of the Bid.
- B8.4 Paragraph 13 of Form A: Bid/Proposal shall be signed in accordance with the following requirements:
- (a) if the Bidder is a sole proprietor carrying on business in his/her own name, it shall be signed by the Bidder;
  - (b) if the Bidder is a partnership, it shall be signed by the partner or partners who have authority to sign for the partnership;
  - (c) if the Bidder is a corporation, it shall be signed by its duly authorized officer or officers; and
  - (d) if the Bidder is carrying on business under a name other than his/her own, it shall be signed by the registered owner of the business name, or by the registered owner's authorized officials if the owner is a partnership or a corporation.

B8.4.1 The name and official capacity of all individuals signing Form A: Bid/Proposal should be entered below such signatures.

B8.5 If a Bid is submitted jointly by two (2) or more persons, the word "Bidder" shall mean each and all such persons, and the undertakings, covenants and obligations of such joint Bidders in the Bid and the Contract, when awarded, shall be both joint and several.

## **B9. PRICES**

B9.1 The Bidder shall state a price in Canadian funds for each item of the Work identified on Form B: Prices.

B9.1.1 Prices stated on Form B: Prices shall not include any costs which may be incurred by the Contractor with respect to any applicable funding agreement obligations as outlined in D30. Any such costs shall be determined in accordance with D30.

B9.2 The quantities listed on Form B: Prices are to be considered approximate only. The City will use said quantities for the purpose of comparing Bids.

B9.3 The quantities for which payment will be made to the Contractor are to be determined by the Work actually performed and completed by the Contractor, to be measured as specified in the applicable Specifications.

B9.4 Payments to Non-Resident Contractors are subject to Non-Resident Withholding Tax pursuant to the Income Tax Act (Canada).

B9.5 The Bidder shall enter the Total Bid Price from Form B: Prices into the Total Bid Price field in MERX.

B9.5.1 Bidders are advised that the calculation indicated in B17.4 will prevail over the Total Bid Price entered in MERX.

B9.6 Form B: Prices is organized into Parts: Part 1 of the Work and Part 2 of the Work. Bidders shall provide a total price for each Part and, on the summary sheet, a Total Bid Price consisting of the sum of prices for Part 1 and Part 2.

## **B10. DISCLOSURE**

B10.1 Various Persons provided information or services with respect to this Work. In the City's opinion, this relationship or association does not create a conflict of interest because of this full disclosure. Where applicable, additional material available as a result of contact with these Persons is listed below.

B10.2 The Persons are:

- (a) N/A

## **B11. CONFLICT OF INTEREST AND GOOD FAITH**

B11.1 Further to C3.2, Bidders, by responding to this Tender, declare that no Conflict of Interest currently exists, or is reasonably expected to exist in the future.

B11.2 Conflict of Interest means any situation or circumstance where a Bidder or employee of the Bidder proposed for the Work has:

- (a) other commitments;
- (b) relationships;
- (c) financial interests; or
- (d) involvement in ongoing litigation;

that could or would be seen to:



- (i) exercise an improper influence over the objective, unbiased and impartial exercise of the independent judgment of the City with respect to the evaluation of Bids or award of the Contract; or
  - (ii) compromise, impair or be incompatible with the effective performance of a Bidder's obligations under the Contract;
- (e) has contractual or other obligations to the City that could or would be seen to have been compromised or impaired as a result of its participation in the Tender process or the Work; or
- (f) has knowledge of confidential information (other than confidential information disclosed by the City in the normal course of the Tender process) of strategic and/or material relevance to the Tender process or to the Work that is not available to other bidders and that could or would be seen to give that Bidder an unfair competitive advantage.

**B11.3** In connection with its Bid, each entity identified in B11.2 shall:

- (a) avoid any perceived, potential or actual Conflict of Interest in relation to the procurement process and the Work;
- (b) upon discovering any perceived, potential or actual Conflict of Interest at any time during the Tender process, promptly disclose a detailed description of the Conflict of Interest to the City in a written statement to the Contract Administrator; and
- (c) provide the City with the proposed means to avoid or mitigate, to the greatest extent practicable, any perceived, potential or actual Conflict of Interest and shall submit any additional information to the City that the City considers necessary to properly assess the perceived, potential or actual Conflict of Interest.

**B11.4** Without limiting B11.3, the City may, in its sole discretion, waive any and all perceived, potential or actual Conflicts of Interest. The City's waiver may be based upon such terms and conditions as the City, in its sole discretion, requires to satisfy itself that the Conflict of Interest has been appropriately avoided or mitigated, including requiring the Bidder to put into place such policies, procedures, measures and other safeguards as may be required by and be acceptable to the City, in its sole discretion, to avoid or mitigate the impact of such Conflict of Interest.

**B11.5** Without limiting B11.3, and in addition to all contractual or other rights or rights at law or in equity or legislation that may be available to the City, the City may, in its sole discretion:

- (a) disqualify a Bidder that fails to disclose a perceived, potential or actual Conflict of Interest of the Bidder or any of its employees proposed for the Work;
- (b) require the removal or replacement of any employees proposed for the Work that has a perceived, actual or potential Conflict of Interest that the City, in its sole discretion, determines cannot be avoided or mitigated;
- (c) disqualify a Bidder or employees proposed for the Work that fails to comply with any requirements prescribed by the City pursuant to B11.4 to avoid or mitigate a Conflict of Interest; and
- (d) disqualify a Bidder if the Bidder, or one of its employees proposed for the Work, has a perceived, potential or actual Conflict of Interest that, in the City's sole discretion, cannot be avoided or mitigated, or otherwise resolved.

**B11.6** The final determination of whether a perceived, potential or actual Conflict of Interest exists shall be made by the City, in its sole discretion.

## **B12. QUALIFICATION**

**B12.1** The Bidder shall:

- (a) undertake to be in good standing under The Corporations Act (Manitoba), or properly registered under The Business Names Registration Act (Manitoba), or otherwise properly registered, licensed or permitted by law to carry on business in Manitoba; and
- (b) be financially capable of carrying out the terms of the Contract; and

- (c) have all the necessary experience, capital, organization, and equipment to perform the Work in strict accordance with the terms and provisions of the Contract.
- B12.2 The Bidder and any proposed Subcontractor (for the portion of the Work proposed to be subcontracted to them) shall:
- (a) be responsible and not be suspended, debarred or in default of any obligations to the City. A list of suspended or debarred individuals and companies is available on the Information Connection page at The City of Winnipeg, Corporate Finance, Materials Management Division website at <https://www.winnipeg.ca/matmgt/Templates/files/debar.pdf>
- B12.3 The Bidder and/or any proposed Subcontractor (for the portion of the Work proposed to be subcontracted to them) shall:
- (a) have successfully carried out work similar in nature, scope and value to the Work; and
- (b) be fully capable of performing the Work required to be in strict accordance with the terms and provisions of the Contract; and
- (c) have a written workplace safety and health program if required pursuant to The Workplace Safety and Health Act (Manitoba).
- B12.4 Further to B12.3(c), the Bidder shall, within five (5) Business Days of a request by the Contract Administrator, provide proof satisfactory to the Contract Administrator that the Bidder/Subcontractor has a workplace safety and health program meeting the requirements of The Workplace Safety and Health Act (Manitoba), by providing:
- (a) Written confirmation of a safety and health certification meeting SAFE Work Manitoba's SAFE Work Certified Standard (e.g., COR™ and SECOR™) in the form of:
- (i) a copy of their valid Manitoba COR certificate and Letter of Good Standing (or Manitoba equivalency) as issued under the Certificate of Recognition (COR) Program administered by the Construction Safety Association of Manitoba or by the Manitoba Heavy Construction Association's WORKSAFELY™ COR™ Program; or
- (ii) a copy of their valid Manitoba SECOR™ certificate and Letter of Good Standing (or Manitoba equivalency) as issued under the Small Employer Certificate of Recognition Program (SECOR™) administered by the Construction Safety Association of Manitoba or by the Manitoba Heavy Construction Association's WORKSAFELY™ COR™ Program; or
- (b) a report or letter to that effect from an independent reviewer acceptable to the City. (A list of acceptable reviewers and the review template are available on the Information Connection page at The City of Winnipeg, Corporate Finance, Materials Management Division website at <http://www.winnipeg.ca/matmgt/>).
- B12.5 The Bidder shall submit, within three (3) Business Days of a request by the Contract Administrator, proof satisfactory to the Contract Administrator of the qualifications of the Bidder and of any proposed Subcontractor.
- B12.6 The Bidder shall provide, on the request of the Contract Administrator, full access to any of the Bidder's equipment and facilities to confirm, to the Contract Administrator's satisfaction, that the Bidder's equipment and facilities are adequate to perform the Work.

### **B13. BID SECURITY**

- B13.1 The Bidder shall include in its Bid Submission Bid security in the form of a digital Bid bond, in the amount of at least ten percent (10%) of the Total Bid Price, and agreement to bond of a company registered to conduct the business of a surety in Manitoba, in Form G1: Bid Bond and Agreement to Bond, available on The City of Winnipeg, Corporate Finance, Materials Management Division website at <https://www.winnipeg.ca/MatMgt/templates/files/eBidsecurity.pdf>.
- B13.2 Bid security shall be submitted in a digital format meeting the following criteria:

- (a) the version submitted by the Bidder must have valid digital signatures and seals;
- (b) the version submitted by the Bidder must be verifiable by the City with respect to the totality and wholeness of the bond form, including: the content; all digital signatures and digital seals; with the surety company, or an approved verification service provider of the surety company;
- (c) the version submitted must be viewable, printable and storable in standard electronic file formats compatible with the City, and in a single file. Allowable formats include pdf;
- (d) the verification may be conducted by the City immediately or at any time during the life of the bond and at the discretion of the City with no requirement for passwords or fees; and
- (e) the results of the verification must provide a clear, immediate and printable indication of pass or fail regarding B13.2(a).

B13.3 Bonds failing the verification process will not be considered to be valid and the Bid shall be determined to be non-responsive in accordance with B17.1(a).

B13.4 Bonds passing the verification process will be treated as original and authentic.

B13.4.1 If the Bidder submits alternative Bids, the Bid security shall be in the amount of the specified percentage of the highest Total Bid Price submitted.

B13.5 The Bid security of the successful Bidder and the next two (2) lowest evaluated responsive and responsible Bidders will be released by the City when a Contract for the Work has been duly formed with the successful Bidder and the contract securities are furnished as provided herein. The Bid securities of all other Bidders will be released when a Contract is awarded.

B13.6 The Bid securities of all Bidders will be released by the City as soon as practicable following notification by the Contract Administrator to the Bidders that no award of Contract will be made pursuant to the Tender.

#### **B14. OPENING OF BIDS AND RELEASE OF INFORMATION**

B14.1 Bids will not be opened publicly.

B14.2 Following the Submission Deadline, the names of the Bidders and their Total Bid Prices (unevaluated, and pending review and verification of conformance with requirements) will be available on the MERX website at [www.merx.com](http://www.merx.com).

B14.3 After award of Contract, the name(s) of the successful Bidder(s) and their Contract amount(s) will be available on the MERX website at [www.merx.com](http://www.merx.com).

B14.4 The Bidder is advised that any information contained in any Bid may be released if required by The Freedom of Information and Protection of Privacy Act (Manitoba), by other authorities having jurisdiction, or by law or by City policy or procedures (which may include access by members of City Council).

B14.4.1 To the extent permitted, the City shall treat as confidential information, those aspects of a Bid Submission identified by the Bidder as such in accordance with and by reference to Part 2, Section 17 or Section 18 or Section 26 of The Freedom of Information and Protection of Privacy Act (Manitoba), as amended.

#### **B15. IRREVOCABLE BID**

B15.1 The Bid(s) submitted by the Bidder shall be irrevocable for the time period specified in Paragraph 11 of Form A: Bid/Proposal.

B15.2 The acceptance by the City of any Bid shall not release the Bids of the next two (2) lowest evaluated responsive Bidders and these Bidders shall be bound by their Bids on such Work until a Contract for the Work has been duly formed and the contract securities have been

furnished as herein provided, but any Bid shall be deemed to have lapsed unless accepted within the time period specified in Paragraph 11 of Form A: Bid/Proposal.

**B16. WITHDRAWAL OF BIDS**

B16.1 A Bidder may withdraw his/her Bid without penalty prior to the Submission Deadline.

**B17. EVALUATION OF BIDS**

B17.1 Award of the Contract shall be based on the following bid evaluation criteria:

- (a) compliance by the Bidder with the requirements of the Tender, or acceptable deviation therefrom (pass/fail);
- (b) qualifications of the Bidder and the Subcontractors, if any, pursuant to B12 (pass/fail);
- (c) Total Bid Price; and
- (d) economic analysis of any approved alternative pursuant to B6.

B17.2 Further to B17.1(a), the Award Authority may reject a Bid as being non-responsive if the Bid is incomplete, obscure or conditional, or contains additions, deletions, alterations or other irregularities. The Award Authority may reject all or any part of any Bid, or waive technical requirements or minor informalities or irregularities, if the interests of the City so require.

B17.2.1 Any Bid with an apparent imbalance between the unit prices in Part 1 and Part 2 may be determined to be non-responsive and rejected by the Award Authority in its sole discretion, acting reasonably.

B17.3 Further to B17.1(b), the Award Authority shall reject any Bid submitted by a Bidder who does not demonstrate, in his/her Bid or in other information required to be submitted, that he/she is qualified.

B17.4 Further to B17.1(c), the Total Bid Price shall be the sum of the quantities multiplied by the unit prices for each item shown on Form B: Prices.

B17.4.1 Further to B17.1(a), in the event that a unit price is not provided on Form B: Prices, the City may determine the unit price by dividing the Amount (extended price) by the approximate quantity, for the purposes of evaluation and payment.

B17.4.2 Bidders are advised that the calculation indicated in B17.4 will prevail over the Total Bid Price entered in MERX.

B17.4.3 A Bidder must Bid on a combination of A.2 and A.5 i), or A.3 and A.5 ii) on Form B: Prices but not both.

B17.4.4 A Bidder must Bid on a combination of B.1 and B.4 i), or B.2 and B.4 ii) on Form B: Prices but not both.

B17.4.5 A Bidder must Bid on a combination of G.2, G.5 i), G.5 iii) and G.17, or G.3, G.5 ii), G.5 iv) and G.18 but not both.

B17.4.6 A Bidder must Bid on a combination of H.1, H.4 i) and H.8 i), or H.2, H.4 ii) and H.8 ii) but not both.

B17.4.7 A Bidder must Bid on a combination of I.1, I.4 i) and I.8 i), or I.2, I.4 ii) and I.8 ii) but not both.

B17.4.8 Further to B17.4.3, if a unit price is included for both item A.2 and item A.3, or item A.5 i) and item A.5 ii), the higher unit price will be used for the calculation of the Total Bid Price. The higher unit price will be used for the calculation of the Total Bid Price.

B17.4.9 Further to B17.4.4, if a unit price is included for both item B.1 and item B.2, or item B.4 i) and item B.4 ii), the higher unit price will be used for the calculation of the Total Bid Price.

- B17.4.10 Further to B17.4.5, if a unit price is included for both item G.2 and item G.3, item G.5 i) and item G.5 ii), item G.5 iii) and item G.5 iv), or item G.17 and item G.18, the higher unit price will be used for the calculation of the Total Bid Price.
- B17.4.11 Further to B17.4.6, if a unit price is included for both item H.1 and item H.2, item H.4 i) and item H.4 ii), or item H.8 i) and item H.8 ii), the higher unit price will be used for the calculation of the Total Bid Price.
- B17.4.12 Further to B17.4.7, if a unit price is included for both item I.1 and item I.2, item I.4 i) and item I.4 ii), or item I.8 i) and item I.8 ii), the higher unit price will be used for the calculation of the Total Bid Price.

## **B18. AWARD OF CONTRACT**

- B18.1 The City will give notice of the award of the Contract or will give notice that no award will be made.
- B18.2 The City will have no obligation to award a Contract to a Bidder, even though one (1) or all of the Bidders are determined to be qualified, and the Bids are determined to be responsive.
- B18.2.1 Without limiting the generality of B18.2, the City will have no obligation to award a Contract where:
- (a) the prices exceed the available City funds for the Work;
  - (b) the prices are materially in excess of the prices received for similar work in the past;
  - (c) the prices are materially in excess of the City's cost to perform the Work, or a significant portion thereof, with its own forces;
  - (d) only one (1) Bid is received; or
  - (e) in the judgment of the Award Authority, the interests of the City would best be served by not awarding a Contract.
- B18.3 If funding for the Work is provided to the City of Winnipeg by Manitoba Hydro, Bidders are advised that the terms of D30 shall immediately take effect upon confirmation of such funding, regardless of when funding is confirmed.
- B18.4 Where an award of Contract is made by the City, the award shall be made to the qualified Bidder submitting the lowest evaluated responsive Bid, in accordance with B17.
- B18.4.1 Following the award of contract, a Bidder will be provided with information related to the evaluation of his/her Bid upon written request to the Contract Administrator.
- B18.5 As noted in D3 and identified in Form B: Prices, the Work of Part 2 will be contingent upon Manitoba Hydro approving funding for the Work. If sufficient funding for Part 2 Work is not approved by Manitoba Hydro the City shall have the right to eliminate all or any portion of Part 2 Work in accordance with D2.

## **PART C - GENERAL CONDITIONS**

### **C0. GENERAL CONDITIONS**

- C0.1 The *General Conditions for Construction* (Revision 2020-01-31) are applicable to the Work of the Contract.
- C0.1.1 The *General Conditions for Construction* are available on the Information Connection page at The City of Winnipeg, Corporate Finance, Materials Management Division website at [http://www.winnipeg.ca/matmgt/gen\\_cond.stm](http://www.winnipeg.ca/matmgt/gen_cond.stm)
- C0.2 A reference in the Tender to a section, clause or subclause with the prefix “**C**” designates a section, clause or subclause in the *General Conditions for Construction*.

## **PART D - SUPPLEMENTAL CONDITIONS**

### **GENERAL**

#### **D1. GENERAL CONDITIONS**

D1.1 In addition to the General Conditions for Construction, these Supplemental Conditions are applicable to the Work of the Contract.

#### **D2. FORM OF CONTRACT DOCUMENTS**

D2.1 Notwithstanding C4.1(c) and C4.4, the Contract Documents will be provided to the Contractor electronically and there will be no requirement for execution and return to the City by the Contractor. Accordingly, the provisions under C4.4(a) and C4.4(b) are no longer applicable.

#### **D3. SCOPE OF WORK**

D3.1 The Work to be done under the Contract shall consist of two (2) parts:

- (a) Part 1 – City Funded Work; and
- (b) Part 2 – Manitoba Hydro Funded Work.

##### **Part 1 – City Funded Work**

D3.2 Part 1 – City Funded Work shall consist of:

- (a) Asphalt Reconstruction:
  - (i) Dowker Avenue from Crowson Bay (East Leg) to South Drive;
  - (ii) Riley Crescent from Wicklow Street to Dowker Avenue;
  - (iii) Grosvenor Avenue from Harrow Street to Stafford Street; and
  - (iv) Alley bounded by Rockwood Street, Dorchester Avenue, Avonherst Street and Yale Avenue;
- (b) Pavement Rehabilitation:
  - (i) Grosvenor Avenue from Ash Street to Lindsay Street;
  - (ii) Nathaniel Street from Grant Avenue to Lorette Avenue;
  - (iii) Nathaniel Street from Fleet Avenue to Dudley Avenue; and
  - (iv) Syracuse Crescent from Chancellor Drive to Chancellor Drive;
- (c) Water and Waste Work:
  - (i) Dowker Avenue from Crowson Bay (East Leg) to South Drive;
  - (ii) Riley Crescent from Wicklow Street to Dowker Avenue;
  - (iii) Grosvenor Avenue from Lindsay Street to Ash Street;
  - (iv) Nathaniel Street from Fleet Avenue to Dudley Avenue;
  - (v) Syracuse Crescent from Chancellor Drive to Chancellor Drive; and
  - (vi) Grosvenor Avenue from Harrow Street to Stafford Street.

##### **Part 2 – Manitoba Hydro Funded Work**

D3.3 Part 2 – Manitoba Hydro Funded Work shall consist of:

- (a) Street Lighting Work:
  - (i) Riley Crescent from Wicklow Street to Dowker Avenue; and
  - (ii) Grosvenor Avenue from Harrow Street to Stafford Street.

- D3.4 The City currently has no approved funding in the Capital Budget for Part 2 of the Work, but is anticipating receiving notification about funding from Manitoba Hydro by late May. Part 2 of the Work is contingent upon Manitoba Hydro approving sufficient funding.
- D3.4.1 Further to C7.1, if notice of sufficient funding is not received, the City shall have the right to eliminate all or any portion of Part 2, and the Contract Price will be reduced accordingly.
- D3.4.2 Further to C7.5, C7.5.1, and C7.6, a reduction in the Contract Price pursuant to D3.4.1 shall not be considered in calculating the aggregate reduction in the Contract Price for purposes of C7.5.
- D3.4.3 If all or any portion of Part 2 is eliminated pursuant to D3.4.1, the time periods stipulated in D20 for Substantial Performance of the Work and in D21 for Total Performance of the Work will be reduced proportionally by the Contract Administrator acting reasonably.
- D3.5 The major components of the Work are as follows:
- (a) Part 1 – Asphalt Reconstruction:
- (i) remove existing pavement;
  - (ii) excavation;
  - (iii) repair of existing sewer and manholes as required;
  - (iv) installation of subdrains;
  - (v) compaction of existing subgrade;
  - (vi) installation of catch basins and connecting pipe;
  - (vii) placement of separation/reinforcement fabric;
  - (viii) placement of sub-base and base course materials;
  - (ix) installation of street lighting as required;
  - (x) construct curb and gutter utilizing slip-form paving equipment;
  - (xi) adjustment of existing drainage inlets, valves and manholes as required;
  - (xii) construct one hundred fifty (150) millimetre (mm) concrete pavement (reinforced) as required at tie-ins;
  - (xiii) construct one hundred fifty (150) mm barrier curb (separate) as required at tie-ins;
  - (xiv) renewal of existing sidewalk;
  - (xv) construct new sidewalk as required;
  - (xvi) placement of asphalt pavement utilizing grade control equipment (average thickness roughly one hundred twenty (120) mm);
  - (xvii) reflective crack maintenance for new asphalt as required and along all new curb and gutter; and
  - (xviii) boulevard grading and sodding;
- (b) Part 1 – Pavement Rehabilitation:
- (i) planing of existing asphalt and concrete pavement as required for headers;
  - (ii) partial depth concrete repairs of existing transverse joints as required;
  - (iii) full depth concrete repairs of the existing slabs and joints as required;
  - (iv) repair of existing sewer and manholes as required;
  - (v) renewal of existing curbs and sidewalks as required;
  - (vi) construct new sidewalk as required;
  - (vii) adjustment of existing drainage inlets, valves and manholes;
  - (viii) boulevard grading and sodding;
  - (ix) cleaning of all catch basins and catch pits in the project area;
  - (x) placement of mainline asphalt overlay (average thickness – eighty (80) mm) utilizing automatic grade control for final lift;
  - (xi) pavement repair fabric reinforcement installation as required; and
  - (xii) reflective crack maintenance for new asphalt, as required;



- (c) Part 1 – Water and Waste Work:
  - (i) installation of watermain and water service insulation as required;
  - (ii) repair of sewer as required;
  - (iii) inspection of sewer repairs;
  - (iv) replace manhole benching as required;
  - (v) replace standard frames for manholes and catch basins as required;
  - (vi) replace existing concrete risers as required; and
  - (vii) patch existing manholes as required;
- (d) Part 2 – Manitoba Hydro Street Lighting:
  - (i) removal of existing street light poles;
  - (ii) installation of conduit cable; and
  - (iii) installation of new bases and poles.

#### **D4. CONTRACT ADMINISTRATOR**

D4.1 The Contract Administrator is Dillon Consulting Limited, represented by:

Jeff Crang, P.Eng.  
Project Manager

Telephone No. 204 509-8745  
Email Address jcrang@dillon.ca

D4.2 At the pre-construction meeting, Jeff Crang, P.Eng. will identify additional personnel representing the Contract Administrator and their respective roles and responsibilities for the Work.

#### **D5. CONTRACTOR'S SUPERVISOR**

D5.1 At the pre-construction meeting, the Contractor shall identify his/her designated supervisor and any additional personnel representing the Contractor and their respective roles and responsibilities for the Work.

D5.2 At least two (2) Business Days prior to the commencement of any Work on the Site, the Contractor shall provide the Contract Administrator with a phone number where the supervisor identified in D5.1 or an alternate can be contacted twenty-four (24) hours a day to respond to an emergency.

#### **D6. NOTICES**

D6.1 Except as provided for in C22.4, all notices, requests, nominations, proposals, consents, approvals, statements, authorizations, documents or other communications to the Contractor shall be sent to the address or facsimile number identified by the Contractor in Paragraph 2 of Form A: Bid/Proposal.

D6.2 All notices, requests, nominations, proposals, consents, approvals, statements, authorizations, documents or other communications to the City, except as expressly otherwise required in D6.3 or elsewhere in the Contract, shall be sent to the attention of the Contract Administrator identified in D4.

D6.3 All notices, requests, nominations, proposals, consents, approvals, statements, authorizations, documents or other communications required to be submitted or returned to the City Solicitor shall be sent to the following facsimile number:

The City of Winnipeg  
Legal Services Department  
Attn: Director of Legal Services  
Facsimile No.: 204-947-9155

## **D7. FURNISHING OF DOCUMENTS**

- D7.1 Upon award of the Contract, the Contractor will be provided with 'issued for construction' Contract Documents electronically, including Drawings in PDF format only.

## **SUBMISSIONS**

### **D8. AUTHORITY TO CARRY ON BUSINESS**

- D8.1 The Contractor shall be in good standing under The Corporations Act (Manitoba), or properly registered under The Business Names Registration Act (Manitoba), or otherwise properly registered, licensed or permitted by law to carry on business in Manitoba, or if the Contractor does not carry on business in Manitoba, in the jurisdiction where the Contractor does carry on business, throughout the term of the Contract, and shall provide the Contract Administrator with evidence thereof upon request.

### **D9. SAFE WORK PLAN**

- D9.1 The Contractor shall provide the Contract Administrator with a Safe Work Plan at least five (5) Business Days prior to the commencement of any Work on the Site but in no event later than the date specified in C4.1 for the return of the executed Contract Documents, if applicable.
- D9.2 The Safe Work Plan shall be prepared and submitted in the format shown in the City's template which is available on the Information Connection page at The City of Winnipeg, Corporate Finance, Materials Management Division website at <http://www.winnipeg.ca/matmgt/safety/default.stm>.
- D9.3 Notwithstanding B12.4 at any time during the term of the Contract, the City may, at its sole discretion and acting reasonably, require an updated COR Certificate or Annual Letter of good Standing. A Contractor, who fails to provide a satisfactory COR Certificate or Annual Letter of good Standing, will not be permitted to continue to perform any Work.

### **D10. INSURANCE**

- D10.1 The Contractor shall provide and maintain the following insurance coverage:
- (a) commercial general liability insurance, in the amount of at least two million dollars (\$2,000,000.00) inclusive, with The City of Winnipeg added as an additional insured, with a cross-liability clause, such liability policy to also contain contractual liability, unlicensed motor vehicle liability, non-owned automobile liability, broad form property damage cover and products and completed operations, to remain in place at all times during the performance of the Work and throughout the warranty period;
  - (b) Automobile Liability Insurance covering all motor vehicles, owned and operated and used or to be used by the Contractor directly or indirectly in the performance of the Work. The Limit of Liability shall not be less than two million dollars (\$2,000,000.00) inclusive for loss or damage including personal injuries and death resulting from any one accident or occurrence;
  - (c) an all risks Installation Floater carrying adequate limits to cover all machinery, equipment, supplies and/or materials intended to enter into and form part of any installation; and
  - (d) property insurance for all equipment, tools, field office, and portable toilets used by the Contractor directly or indirectly in the performance of the Work on the project that may be owned, rented, leased, or borrowed.
- D10.2 If required by Contract, Manitoba Hydro, BellMTS to be added to the commercial general liability policy outlined in D10.1(a) above as an additional insured.
- D10.3 Deductibles shall be borne by the Contractor.

- D10.4 The Contractor shall provide the City Solicitor with a certificate(s) of insurance, in a form satisfactory to the City Solicitor, at least two (2) Business Days prior to the commencement of any Work but in no event later than the date specified in the C4.1 for the return of the executed Contract Documents, as applicable.
- D10.5 All policies shall be taken out with insurers duly licensed to carry on business in the Province of Manitoba.
- D10.6 The Contractor shall not cancel, materially alter, or cause each policy to lapse without providing at least thirty (30) Calendar Days prior written notice to the Contract Administrator.

## **D11. CONTRACT SECURITY**

- D11.1 The Contractor shall provide and maintain the performance bond and the labour and material payment bond until the expiration of the warranty period in the form of:
- (a) a performance bond of a company registered to conduct the business of a surety in Manitoba, in the form attached to these Supplemental Conditions (Form H1: Performance Bond), in the amount of fifty percent (50%) of the Contract Price; and
  - (b) a labour and material payment bond of a company registered to conduct the business of a surety in Manitoba, in the form attached to these Supplemental Conditions (Form H2: Labour and Material Payment Bond), in an amount equal to fifty percent (50%) of the Contract Price.
- D11.1.1 Where the contract security is a performance bond, it may be submitted in hard copy or digital format. If submitted in digital format the contract security must meet the following criteria:
- (a) the version submitted by the Contractor must have valid digital signatures and seals;
  - (b) the version submitted by the Contractor must be verifiable by the City with respect to the totality and wholeness of the bond form, including: the content; all digital signatures and digital seals; with the surety company, or an approved verification service provider of the surety company;
  - (c) the version submitted must be viewable, printable and storable in standard electronic file formats compatible with the City, and in a single file. Allowable formats include pdf;
  - (d) the verification may be conducted by the City immediately or at any time during the life of the bond and at the discretion of the City with no requirement for passwords or fees; and
  - (e) the results of the verification must provide a clear, immediate and printable indication of pass or fail regarding D11.1(b).
- D11.1.2 Digital bonds failing the verification process will not be considered to be valid and may be determined to be an event of default in accordance with C18.1. If a digital bond fails the verification process, the Contractor may provide a replacement bond (in hard copy or digital format) within seven (7) Calendar Days of the City's request or within such greater period of time as the City in its discretion, exercised reasonably, allows.
- D11.1.3 Digital bonds passing the verification process will be treated as original and authentic.
- D11.2 The Contractor shall provide the City Solicitor with the required performance and labour and material payment bonds within seven (7) Calendar Days of notification of the award of the Contract by way of an award letter and prior to the commencement of any Work on the Site but in no event later than the date specified in C4.1 for the return of the executed Contract Documents, if applicable.
- D11.3 The Contractor shall, as soon as practicable after entering into a contract with a Subcontractor:
- (a) give the Subcontractor written notice of the existence of the labour and material payment bond in D11.1(b); and

- (b) post a notice of the bond and/or a copy of that bond in a conspicuous location at the Site of the Work.

#### **D12. SUBCONTRACTOR LIST**

- D12.1 The Contractor shall provide the Contract Administrator with a complete list of the Subcontractors whom the Contractor proposes to engage (Form J: Subcontractor List) at or prior to a pre-construction meeting, or at least two (2) Business Days prior to the commencement of any Work on the Site but in no event later than the date specified in the C4.1 for the return of the executed Contract Documents, if applicable.

#### **D13. EQUIPMENT LIST**

- D13.1 The Contractor shall provide the Contract Administrator with a complete list of the equipment which the Contractor proposes to utilize (Form K: Equipment List) at or prior to a pre-construction meeting, or at least two (2) Business Days prior to the commencement of any Work on the Site but in no event later than the date specified in the C4.1 for the return of the executed Contract Documents, if applicable.

#### **D14. DETAILED WORK SCHEDULE**

- D14.1 The Contractor shall provide the Contract Administrator with a detailed work schedule (Form L: Detailed Work Schedule) at least two (2) Business Days prior to the commencement of any Work on the Site but in no event later than the date specified in the General Conditions for the return of the executed Contract Documents, as applicable.
- D14.2 If, prior to submitting the Detailed Work Schedule, the Contractor does not receive notification pursuant to D15.4 that all or some portion of Part 2 of the Work may be commenced, he/she shall complete Form L: Detailed Work Schedule for only Part 1 of the Work assuming that, if all of Part 2 is eliminated, the time periods stipulated in D20 for Substantial Performance of the Work and in D21 for Total Performance of the Work will be reduced by two (2) Working Days.
- D14.3 If, after submitting the Detailed Work Schedule, the Contractor receives notification that all or any portion of Part 2 of the Work may be commenced, he/she shall submit a revised Detailed Work Schedule no later than two (2) Business Days from receipt of the notification.
- D14.4 The detailed work schedule shall consist of the following:
  - (a) a critical path method (C.P.M.) schedule for the Work; and
  - (b) a Gantt chart for the Work based on the C.P.M. schedule.all acceptable to the Contract Administrator.
- D14.5 Further to D14.4(a), the C.P.M. schedule shall clearly identify the start and completion dates of all of the following activities/tasks making up the Work as well as showing those activities/tasks on the critical path:
- D14.6 Further to D14.4(b), the Gantt chart shall show the time on a weekly basis, required to carry out the Work of each trade, or specification division. The time shall be on the horizontal axis, and the type of trade shall be on the vertical axis.

### **SCHEDULE OF WORK**

#### **D15. COMMENCEMENT**

- D15.1 The Contractor shall not commence any Work until he/she is in receipt of an award letter from the Award Authority authorizing the commencement of the Work.

- D15.2 The Contractor shall not commence any Work on the Site until:
- (a) the Contract Administrator has confirmed receipt and approval of:
    - (i) evidence of authority to carry on business specified in D8;
    - (ii) evidence of the workers compensation coverage specified in C6.15;
    - (iii) the twenty-four (24) hour emergency response phone number specified in D5.2;
    - (iv) the Safe Work Plan specified in D9;
    - (v) evidence of the insurance specified in D10;
    - (vi) the contract security specified in D11;
    - (vii) the subcontractor list specified in D12;
    - (viii) the equipment list specified in D13; and
    - (ix) the detailed work schedule specified in D14;
  - (b) the Contractor has attended a pre-construction meeting with the Contract Administrator, or the Contract Administrator has waived the requirement for a pre-construction meeting.
- D15.3 The Contractor shall not commence the Work on the Site before May 25, 2021, and shall commence the Work on Site no later than June 7, 2021, as directed by the Contract Administrator and weather permitting.
- D15.4 The Contractor shall not commence Part 2 of the Work as described in D3 and identified in Form B: Prices, unless he/she has received notification from the Contract Administrator that the City has received notice of sufficient funding from Manitoba Hydro.

## **D16. WORKING DAYS**

- D16.1 Further to C1.1(tt);
- D16.1.1 The Contract Administrator will determine daily if a Working Day has elapsed and will record his/her assessment. On a weekly basis the Contract Administrator will provide the Contractor with a record of the Working Days assessed for the preceding week. The Contractor shall sign each report signifying that he/she agrees with the Contract Administrator's determination of the Working Days assessed for the report period.
- D16.1.2 Work done to restore the Site to a condition suitable for Work, shall not be considered "work" as defined in the definition of a Working Day.
- D16.1.3 When the Work includes two (2) or more major types of Work that can be performed under different atmospheric conditions, the Contract Administrator shall consider all major types of Work in determining whether the Contractor was able to work in assessing Working Days.
- D16.1.4 Further to D16.1, if a Contractor receives permission from the Contract Administrator for work to be performed on Saturdays, each Saturday worked will be considered a Working Day.

## **D17. RESTRICTED WORK HOURS**

- D17.1 Further to clause 3.10 of CW 1130, the Contractor shall require written permission forty-eight (48) hours in advance from the Contract Administrator for any work to be performed between 2000 hours and 0700 hours, or on Saturdays, Sundays, Statutory Holidays and or Civic Holidays.

## **D18. WORK BY OTHERS**

- D18.1 Work by others on or near the Site will include but not necessarily be limited to:
- (a) Manitoba Hydro:
    - (i) supply and inspection of new street lighting hardware (to be installed by the Contractor) and the de-energizing and energizing of the new street light plant;

- (ii) relocation of existing street light poles as required in this Contract; and
  - (iii) adjusting Manitoba Hydro manhole lids;
- (b) Manitoba Hydro Gas Divisions:
  - (i) gas services will be lowered if required on reconstruction roadwork locations. This Work should be coordinated immediately after excavation has taken place;
- (c) BellMTS:
  - (i) miscellaneous adjustments of manholes, relocation of BellMTS boxes and other appurtenances that may be required within this Contract;
- (d) City of Winnipeg Traffic Signals:
  - (i) relocation and replacement of conduit and bases.

## **D19. SEQUENCE OF WORK**

D19.1 Further to C6.1, the sequence of work shall comply with the following:

- D19.1.1 Providing that the Work on each street is completed in a similar order to the order that the Work was commenced in, the Contractor will be permitted to have a maximum of three (3) streets under construction at any one (1) time. Completion of a street means that all of the necessary concrete, asphalt including approaches and landscaping Work is completed to the satisfaction of the Contract Administrator.
- D19.1.2 Where the Contractor utilizes two (2) or more crews that work independently on the same major component of the Work as identified in D3, the Contract Administrator may approve an increase to the maximum number of streets under construction at any time.
- D19.1.3 Placing the topsoil and finished grading of all boulevard and median areas shall be completed prior to commencing construction of asphaltic concrete overlays, including scratch courses.
- D19.1.4 The Contractor will not be permitted to plane the road surface, and then open to traffic without approval by the Contract Administrator. In general, planing should be limited to lanes under construction.
- D19.1.5 Work on Dowker Street shall be separated into two (2) phases and Riley Street will only commence once Phase 1 has been completed and opened. The recommended sequence of Work will be as follows:
  - (a) Stage 1 – Dowker Street from Crowson Bay to South Drive. The Contractor will reconstruct the road way in two (2) phases to maintain local access:
    - (i) Phase 1 – Crowson Bay to Wicklow Place; and
    - (ii) Phase 2 – Wicklow Place to South Drive;
  - (b) Stage 1 – Riley Crescent from Wicklow Street to Dowker Street. The Contractor shall not start the construction until the completion of Dowker Street Phase 1 – Crowson Bay to Wicklow Place;
  - (c) Stage 1 – Syracuse Crescent from Chancellor Drive to Chancellor Drive;
  - (d) Stage 2 – Nathaniel Street from Grant Avenue to Lorette Avenue;
  - (e) Stage 2 – Nathaniel Street from Fleet Avenue to Ash Street;
  - (f) Stage 2 – Alley bounded by Rockwood Street, Dorchester Avenue, McMillan Avenue and Wilton Street;
  - (g) Stage 3 – Grosvenor Avenue from Harrow Street to Stafford Street;
  - (h) Stage 3 – Grosvenor Avenue from Ash Street to Lindsay Street; and
  - (i) Stage 3 – Alley bounded by Harvard Avenue, Stafford Avenue, Avonherst Street and Yale Street.

D19.1.6 Potential alterations to the sequence of Work must be presented in writing to the Contract Administrator at least one (1) week in advance of a requested change. No changes to sequence of Work may occur until approval provided by the Contract Administrator.

## **D20. SUBSTANTIAL PERFORMANCE**

D20.1 The Contractor shall achieve Substantial Performance within seventy-seven (77) consecutive Working Days of the commencement of the Work as specified in D15.

D20.2 When the Contractor considers the Work to be substantially performed, the Contractor shall arrange, attend and assist in the inspection of the Work with the Contract Administrator for purposes of verifying Substantial Performance. Any defects or deficiencies in the Work noted during that inspection shall be remedied by the Contractor at the earliest possible instance and the Contract Administrator notified so that the Work can be re-inspected.

D20.3 The date on which the Work has been certified by the Contract Administrator as being substantially performed to the requirements of the Contract through the issue of a certificate of Substantial Performance is the date on which Substantial Performance has been achieved.

## **D21. TOTAL PERFORMANCE**

D21.1 The Contractor shall achieve Total Performance within eighty-two (82) consecutive Working Days of the commencement of the Work as specified in D15.

D21.2 When the Contractor or the Contract Administrator considers the Work to be totally performed, the Contractor shall arrange, attend and assist in the inspection of the Work with the Contract Administrator for purposes of verifying Total Performance. Any defects or deficiencies in the Work noted during that inspection shall be remedied by the Contractor at the earliest possible instance and the Contract Administrator notified so that the Work can be re-inspected.

D21.3 The date on which the Work has been certified by the Contract Administrator as being totally performed to the requirements of the Contract through the issue of a certificate of Total Performance is the date on which Total Performance has been achieved.

## **D22. LIQUIDATED DAMAGES**

D22.1 If the Contractor fails to achieve Substantial Performance or Total Performance in accordance with the Contract by the days fixed herein for same, the Contractor shall pay the City the following amounts per Working Day for each and every Working Day following the days fixed herein for same during which such failure continues:

- (a) Substantial Performance – three thousand dollars (\$3,000.00); and
- (b) Total Performance – one thousand five hundred dollars (\$1,500.00).

D22.2 The amounts specified for liquidated damages in D22.1 are based on a genuine pre-estimate of the City's losses in the event that the Contractor does not achieve Substantial Performance or Total Performance by the days fixed herein for same.

D22.3 The City may reduce any payment to the Contractor by the amount of any liquidated damages assessed.

## **D23. COVID-19 SCHEDULE DELAYS**

D23.1 The City acknowledges that the schedule for this Contract may be impacted by the COVID-19 pandemic. Commencement and progress of the Work shall be performed by the Contractor with due consideration to the health and safety of workers and the public, directives from health authorities and various levels of government and in close consultation with the Contract Administrator.

- D23.2 If the Contractor is delayed in the performance of the Work by reason of the COVID-19 pandemic, the Work schedule may be adjusted by a period of time equal to the time lost due to such delay and costs related to such delay will be determined as identified herein.
- D23.3 A minimum of seven (7) Calendar Days prior to the commencement of Work, the Contractor shall declare whether COVID-19 will affect the start date. The Contractor shall provide sufficient evidence that the delay is directly related to COVID-19, including but not limited to evidence related to availability of staff, availability of Material or work by others.
- D23.4 For any delay related to COVID-19 and identified after Work has commenced, the Contractor shall within seven (7) Calendar Days of becoming aware of the anticipated delay declare the additional delay and shall provide sufficient evidence as indicated in D23.3. Failure to provide this notice will result in no additional time delays being considered by the City.
- D23.5 The Work schedule, including the durations identified in D20 to D21 where applicable, will be adjusted to reflect delays accepted by the Contract Administrator. No additional payment will be made for adjustment of schedules except where seasonal work, not previously identified in the Contract, is carried over to the following construction season.
- D23.6 Where Work not previously identified is being carried over solely as a result of delays related to COVID-19, as confirmed by the Contract Administrator, the cost of temporary works to maintain the Work in a safe manner until Work recommences, will be considered by the Contract Administrator. Where the Work is carried over only partially due to COVID-19, a partial consideration of the cost of temporary works will be considered by the Contract Administrator.
- D23.7 Any time or cost implications as a result of COVID-19 and in accordance with the above, as confirmed by the Contract Administrator, shall be documented in accordance with C7.

#### **D24. SCHEDULED MAINTENANCE**

- D24.1 The Contractor shall perform the following scheduled maintenance in the manner and within the time periods required by the Specifications:
- (a) Reflective Crack Maintenance (during one (1) year warranty period) as specified in CW 3250 – R7;
  - (b) sodding (maintenance period) as specified in CW 3510 – R9; and
  - (c) seeding (maintenance period) as specified in CW 3520 – R9.
- D24.2 Determination of Substantial Performance and Total Performance shall be exclusive of scheduled maintenance identified herein. All scheduled maintenance shall be completed prior to the expiration of the warranty period. Where the scheduled maintenance cannot be completed during the warranty period, the warranty period shall be extended for such period of time as it takes the Contractor to complete the scheduled maintenance.

#### **CONTROL OF WORK**

##### **D25. JOB MEETINGS**

- D25.1 Regular weekly job meetings will be held at the Site. These meetings shall be attended by a minimum of one (1) representative of the Contract Administrator, one (1) representative of the City and one (1) representative of the Contractor. Each representative shall be a responsible person capable of expressing the position of the Contract Administrator, the City and the Contractor respectively on any matter discussed at the meeting including the Work schedule and the need to make any revisions to the Work schedule. The progress of the Work will be reviewed at each of these meetings.
- D25.2 The Contract Administrator reserves the right to cancel any job meeting or call additional job meetings whenever he/she deems it necessary.



**D26. PRIME CONTRACTOR – THE WORKPLACE SAFETY AND HEALTH ACT (MANITOBA)**

D26.1 Further to C6.26, the Contractor shall be the Prime Contractor and shall serve as, and have the duties of the Prime Contractor in accordance with The Workplace Safety and Health Act (Manitoba).

**D27. THE WORKPLACE SAFETY AND HEALTH ACT (MANITOBA) – QUALIFICATIONS**

D27.1 Further to B12.4, the Contractor/Subcontractor must, throughout the term of the Contract, have a Workplace Safety and Health Program meeting the requirements of The Workplace Safety and Health Act (Manitoba). At any time during the term of the Contract, the City may, at its sole discretion and acting reasonably, require updated proof of compliance, as set out in B12.4.

**MEASUREMENT AND PAYMENT**

**D28. PAYMENT**

D28.1 Further to C12, the City may at its option pay the Contractor by direct deposit to the Contractor's banking institution.

**WARRANTY**

**D29. WARRANTY**

D29.1 Notwithstanding C13.2, the warranty period shall begin on the date of Substantial Performance and shall expire one (1) years thereafter for pavement rehabilitation works and Water and Waste works, and two (2) years thereafter for pavement reconstruction works, unless extended pursuant to C13.2.1 or C13.2.2, in which case it shall expire when provided for thereunder.

**THIRD PARTY AGREEMENTS**

**D30. FUNDING AND/OR CONTRIBUTION AGREEMENT OBLIGATIONS**

D30.1 In the event that funding for the Work of the Contract is provided to the City of Winnipeg by Manitoba Hydro, the following terms and conditions shall apply, as required by the applicable funding agreements.

D30.2 Further to D30.1, in the event that the obligations in D30 apply, actual costs legitimately incurred by the Contractor as a direct result of these obligations ("Funding Costs") shall be determined by the actual cost to the Contractor and not by the valuation method(s) outlined in C7.4. In all other respects Funding Costs will be processed in accordance with Changes in Work under C7.

D30.3 For the purposes of D30, "**Manitoba Hydro**" includes the authorized officials, auditors and representatives of Manitoba Hydro.

D30.4 Modified Insurance Requirements

D30.4.1 If not already required under the insurance requirements identified in D10, the Contractor will be required to provide wrap-up liability insurance in an amount of no less than two million dollars (\$2,000,000) inclusive per occurrence. Such policy will be written in the joint names of the City, Contractor, Consultants and all sub-contractors and sub-consultants and include twelve (12) months completed operations. Manitoba Hydro employees and agents shall be added as additional insureds.

D30.4.2 If not already required under the insurance requirements identified in D10, the Contractor will be required to provide builders' risk insurance (including boiler and machinery insurance, as applicable) providing all risks coverage at full replacement cost, or such

lower level of insurance that the City may identify on a case-by-case basis, such as an installation floater.

D30.4.3 The Contractor shall obtain and maintain third party liability insurance with minimum coverage of two million dollars (\$2,000,000.00) per occurrence on all licensed vehicles operated at the Site. In the event that this requirement conflicts with another licensed vehicle insurance requirement in this Contract, then the requirement that provides the higher level of insurance shall apply.

D30.4.4 Further to D10.4, insurers shall provide satisfactory Certificates of Insurance to Manitoba Hydro prior to commencement of Work as written evidence of the insurance required. The Certificates of Insurance must provide for a minimum of thirty (30) days' prior written notice to Manitoba Hydro in case of insurance cancellation.

D30.4.5 All policies must be taken out with insurers licensed to carry on business in the Province of Manitoba.

#### D30.5 Indemnification By Contractor

D30.5.1 In addition to the indemnity obligations outlined in C17 of the General Conditions for Construction, the Contractor agrees to indemnify and save harmless Manitoba Hydro and each of their respective servants, employees, and agents from and against all claims and demands, losses, costs, damages, actions, suit or other proceedings brought or pursued in any manner in respect of any matter caused by the Contractor or arising from this Contract or the Work, or from the goods or services provided or required to be provided by the Contractor, except those resulting from the negligence of any of Manitoba Hydro's employees or agents, as the case may be.

#### D30.6 Records Retention and Audits

D30.6.1 The Contractor shall maintain and preserve accurate and complete records in respect of this Contract and the Work, including all accounting records, financial documents, copies of contracts with other parties and other records relating to this Contract and the Work during the term of the Contract and for at least six (6) years after Total Performance. Those records bearing original signatures or professional seals or stamps must be preserved in paper form; other records may be retained in electronic form.

D30.6.2 In addition to the record keeping and inspection obligations outlined in C6 of the General Conditions for Construction, the Contractor shall keep available for inspection and audit at all reasonable times while this Contract is in effect and until at least six (6) years after Total Performance, all records, documents, and contracts referred to in D30.6.1 for inspection, copying and audit by the City of Winnipeg and/or Manitoba Hydro and their respective representatives and auditors, and to produce them on demand; to provide reasonable facilities for such inspections, copying and audits, to provide copies of and extracts from such records, documents, or contracts upon request by the City of Winnipeg and/or Manitoba Hydro and their respective representatives and auditors, and to promptly provide such other information and explanations as may be reasonably requested by the City of Winnipeg and/or Manitoba Hydro from time-to-time.

#### D30.7 Other Obligations

D30.7.1 The Contractor consents to the City providing a copy of the Contract Documents to Manitoba Hydro upon request.

D30.7.2 If the Lobbyists Registration Act (Manitoba) applies to the Contractor, the Contractor represents and warrants that it has filed a return and is registered and in full compliance with the obligations of that Act, and covenants that it will continue to comply for the duration of this Contract.

D30.7.3 The Contractor shall comply with all applicable legislation and standards, whether federal, provincial, or municipal, including (without limitation) labour, environmental, and human rights laws, in the course of providing the Work.

- D30.7.4 The Contractor shall properly account for the Work provided under this Contract and payment received in this respect, prepared in accordance with generally accepted accounting principles in effect in Canada, including those principles and standards approved or recommended from time-to-time by the Chartered Professional Accountants of Canada or the Public Sector Accounting Board, as applicable, applied on a consistent basis.
- D30.7.5 The Contractor represents and warrants that no current or former public servant or public office holder, to whom the Value and Ethics Code for the Public Sector, the Policy on Conflict of Interest and Post Employment, or the Conflict of Interest Act applies, shall derive direct benefit from this Contract, including any employment, payments, or gifts, unless the provision or receipt of such benefits is in compliance with such codes and the legislation.
- D30.7.6 The Contractor represents and warrants that no member of the House of Commons or of the Senate of Canada or of the Legislative Assembly of Manitoba is a shareholder, director or officer of the Contractor or of a Subcontractor, and that no such member is entitled to any benefits arising from this Contract or from a contract with the Contractor or a Subcontractor concerning the Work.

**FORM H1: PERFORMANCE BOND**  
(See D11)

KNOW ALL MEN BY THESE PRESENTS THAT

\_\_\_\_\_ ,  
(hereinafter called the "Principal"), and

\_\_\_\_\_ ,  
(hereinafter called the "Surety"), are held and firmly bound unto **THE CITY OF WINNIPEG** (hereinafter called the "Obligee"), in the sum of

\_\_\_\_\_ dollars (\$ \_\_\_\_\_)

of lawful money of Canada to be paid to the Obligee, or its successors or assigns, for the payment of which sum the Principal and the Surety bind themselves, their heirs, executors, administrators, successors and assigns, jointly and severally, firmly by these presents.

WHEREAS the Principal has entered into a written contract with the Obligee for

TENDER NO. 618-2020

2021 Local Streets Renewal Program 21-R-05: Dowker Avenue and Various other Locations which is by reference made part hereof and is hereinafter referred to as the "Contract".

NOW THEREFORE the condition of the above obligation is such that if the Principal shall:

- (a) carry out and perform the Contract and every part thereof in the manner and within the times set forth in the Contract and in accordance with the terms and conditions specified in the Contract;
- (b) perform the Work in a good, proper, workmanlike manner;
- (c) make all the payments whether to the Obligee or to others as therein provided;
- (d) in every other respect comply with the conditions and perform the covenants contained in the Contract; and
- (e) indemnify and save harmless the Obligee against and from all loss, costs, damages, claims, and demands of every description as set forth in the Contract, and from all penalties, assessments, claims, actions for loss, damages or compensation whether arising under "The Workers Compensation Act", or any other Act or otherwise arising out of or in any way connected with the performance or non-performance of the Contract or any part thereof during the term of the Contract and the warranty period provided for therein;

THEN THIS OBLIGATION SHALL BE VOID, but otherwise shall remain in full force and effect. The Surety shall not, however, be liable for a greater sum than the sum specified above.

AND IT IS HEREBY DECLARED AND AGREED that the Surety shall be liable as Principal, and that nothing of any kind or matter whatsoever that will not discharge the Principal shall operate as a discharge or release of liability of the Surety, any law or usage relating to the liability of Sureties to the contrary notwithstanding.

IN WITNESS WHEREOF the Principal and Surety have signed and sealed this bond the

\_\_\_\_\_ day of \_\_\_\_\_, 20\_\_\_\_ .

**SIGNED AND SEALED**  
in the presence of:

\_\_\_\_\_  
(Witness as to Principal if no seal)

\_\_\_\_\_  
(Name of Principal)

Per: \_\_\_\_\_ (Seal)

Per: \_\_\_\_\_

\_\_\_\_\_  
(Name of Surety)

By: \_\_\_\_\_ (Seal)  
(Attorney-in-Fact)

**FORM H2: LABOUR AND MATERIAL PAYMENT BOND**  
(See D11)

KNOW ALL MEN BY THESE PRESENTS THAT

\_\_\_\_\_  
his/its heirs, executors, administrators, successors or assigns (hereinafter called the "Principal"), and

\_\_\_\_\_  
his/its heirs, executors, administrators, successors or assigns (hereinafter called the "Surety"), are held and firmly bound unto **THE CITY OF WINNIPEG** (hereinafter called the "Obligee"), for the use and benefit of claimants as herein below defined, in the amount of

\_\_\_\_\_ dollars (\$\_\_\_\_\_)

of lawful money of Canada, for the payment whereof we, the Principal and the Surety jointly and severally bind ourselves firmly by these presents.

WHEREAS the Principal has entered into a written contract with the Obligee for

TENDER NO. 618-2020

2021 Local Streets Renewal Program 21-R-05: Dowker Avenue and Various other Locations

which is by reference made part hereof and is hereinafter referred to as the "Contract".

NOW THEREFORE the condition of the above obligation is such that if the Principal shall promptly make payment to all claimants as hereinafter defined, for all labour, service and material used or reasonably required for use in the performance of the Contract, then this obligation shall be void, otherwise it shall remain in full force and effect subject, however, to the following conditions:

- (a) A claimant is defined as one having a direct contract with the Principal for labour, service and material, or any of them, used or reasonably required for use in the performance of the contract, labour, service and material being construed to include that part of water, gas, power, light, heat, oil, gasoline, telephone service or rental of equipment (but excluding rent of equipment where the rent pursuant to an agreement is to be applied towards the purchase price thereof) directly applicable to the Contract;
- (b) The above-named Principal and Surety hereby jointly and severally agree with the Obligee that every claimant as herein defined, who has not been paid in full before the expiration of a period of ninety (90) days after the date on which the last of such claimant's work, labour or service was done or performed, or materials were furnished by such claimant, may sue on this bond, prosecute the suit to final judgment for such sum or sums as may be justly due claimant, and have execution thereon;
- (c) No suit or action shall be commenced hereunder by any claimant
  - (i) unless claimant shall have given written notice to the Principal and the Surety above-named, within one hundred and twenty (120) days after such claimant did or performed the last of the work, labour or service, or furnished the last of the materials for which said claim is made, stating with substantial accuracy the amount claimed and the name of the party to whom the materials were furnished, or for whom the work, labour or service was done or performed. Such notice shall be served by mailing the same by registered mail to the Principal, and Surety, at any place where an office is regularly maintained for the transaction of business, or served in any manner in which legal process may be served in the Province of Manitoba;

- (ii) after the expiration of one (1) year following the date on which Principal ceased work on said Contract; including work performed under the guarantees provided in the Contract;
  - (iii) other than in a court of competent jurisdiction in the Province of Manitoba.
- (d) The amount of this bond shall be reduced by and to the extent of any payment or payments made in good faith hereunder, inclusive of the payment by Surety of mechanics liens which may be filed of record against said improvement, whether or not claim for the amount of such lien be presented under and against this bond.
- (e) The Surety shall not be liable for a greater sum than the specified penalty of this bond.

The Principal and Surety hereby agree that The Guarantors' Liability Act (Manitoba) shall apply to this Bond.

IN TESTIMONY WHEREOF, the Principal has hereunto set its hand affixed its seal, and the Surety has caused these presents to be sealed and with its corporate seal duly attested by the authorized signature of its signing authority this

\_\_\_\_\_ day of \_\_\_\_\_, 20\_\_\_\_.

SIGNED AND SEALED  
in the presence of:

\_\_\_\_\_  
(Witness as to Principal if no seal)

\_\_\_\_\_  
(Name of Principal)

Per: \_\_\_\_\_ (Seal)

Per: \_\_\_\_\_

\_\_\_\_\_  
(Name of Surety)

By: \_\_\_\_\_ (Seal)  
(Attorney-in-Fact)

**FORM J: SUBCONTRACTOR LIST**  
 (See D12)

2021 Local Streets Renewal Program 21-R-05: Dowker Avenue and Various other Locations

<u>Portion of the Work</u>	<u>Name</u>	<u>Address</u>
<b><i>SURFACE WORKS:</i></b>		
<b>Supply of Materials:</b>		
Base Course and Sub-Base		
Geotextile Fabric		
Concrete		
Asphalt		
Sod and Topsoil		
<b>Installation/Placement:</b>		
Asphalt Planing		
Base Course and Sub-Base		
Geotextile Fabric		
Concrete		
Asphalt		
Sod and Topsoil		
<b><i>UNDERGROUND WORKS:</i></b>		
<b>Supply of Materials:</b>		
Catch basins/manholes		
Connecting Pipe		
Subdrains		
<b>Installation/Placement:</b>		
Catch basins/manholes		
Connecting Pipe		
Subdrains		
<b><i>STREET LIGHT WORKS</i></b>		
<b>Installation/Placement:</b>		
Removal of Poles		
Installation of Conduit/Cables		



**FORM J: SUBCONTRACTOR LIST**  
(See D12)

2021 Local Streets Renewal Program 21-R-05: Dowker Avenue and Various other Locations

<u>Portion of the Work</u>	<u>Name</u>	<u>Address</u>
Installation of Bases and Poles		

**FORM K: EQUIPMENT**  
(See D13)

2021 Local Streets Renewal Program 21-R-05: Dowker Avenue and Various other Locations

<p><b>1. Category/type:</b></p> <p>Make/Model/Year: _____ Serial No.: _____</p> <p>Registered owner: _____</p> <p>Make/Model/Year: _____ Serial No.: _____</p> <p>Registered owner: _____</p> <p>Make/Model/Year: _____ Serial No.: _____</p> <p>Registered owner: _____</p>
<p><b>2. Category/type:</b></p> <p>Make/Model/Year: _____ Serial No.: _____</p> <p>Registered owner: _____</p> <p>Make/Model/Year: _____ Serial No.: _____</p> <p>Registered owner: _____</p> <p>Make/Model/Year: _____ Serial No.: _____</p> <p>Registered owner: _____</p>
<p><b>3. Category/type:</b></p> <p>Make/Model/Year: _____ Serial No.: _____</p> <p>Registered owner: _____</p> <p>Make/Model/Year: _____ Serial No.: _____</p> <p>Registered owner: _____</p> <p>Make/Model/Year: _____ Serial No.: _____</p> <p>Registered owner: _____</p>

**FORM K: EQUIPMENT**  
(See D13)

2021 Local Streets Renewal Program 21-R-05: Dowker Avenue and Various other Locations

<p><b>4. Category/type:</b></p> <p>Make/Model/Year: _____ Serial No.: _____</p> <p>Registered owner: _____</p> <p>Make/Model/Year: _____ Serial No.: _____</p> <p>Registered owner: _____</p> <p>Make/Model/Year: _____ Serial No.: _____</p> <p>Registered owner: _____</p>
<p><b>5. Category/type:</b></p> <p>Make/Model/Year: _____ Serial No.: _____</p> <p>Registered owner: _____</p> <p>Make/Model/Year: _____ Serial No.: _____</p> <p>Registered owner: _____</p> <p>Make/Model/Year: _____ Serial No.: _____</p> <p>Registered owner: _____</p>
<p><b>6. Category/type:</b></p> <p>Make/Model/Year: _____ Serial No.: _____</p> <p>Registered owner: _____</p> <p>Make/Model/Year: _____ Serial No.: _____</p> <p>Registered owner: _____</p> <p>Make/Model/Year: _____ Serial No.: _____</p> <p>Registered owner: _____</p>



## PART E - SPECIFICATIONS

### GENERAL

#### E1. APPLICABLE SPECIFICATIONS AND DRAWINGS

- E1.1 These Specifications shall apply to the Work.
- E1.2 *The City of Winnipeg Standard Construction Specifications* in its entirety, whether or not specifically listed on Form B: Prices, shall apply to the Work.
- E1.2.1 *The City of Winnipeg Standard Construction Specifications* is available on the Information Connection page at The City of Winnipeg, Corporate Finance, Materials Management Division website at <http://www.winnipeg.ca/matmgt/Spec/Default.stm>.
- E1.2.2 The version in effect three (3) Business Days before the Submission Deadline shall apply.
- E1.2.3 Further to C2.4(d), Specifications included in the Tender shall govern over *The City of Winnipeg Standard Construction Specifications*.
- E1.3 Bidders are reminded that requests for approval of substitutes as an approved equal or an approved alternative shall be made in accordance with B6. In every instance where a brand name or design specification is used, the City will also consider approved equals and/or approved alternatives in accordance with B6.
- E1.4 The following are applicable to the Work:

<u>Drawing No.</u>	<u>Drawing Name/Title</u>	<u>Drawing (Original) Sheet Size</u>
	Cover Sheet	
01	DOWKER AVENUE – PLAN-PROFILE (START TO STA. 1+155)	
02	DOWKER AVENUE – PLAN-PROFILE (STA. 1+155 TO STA. 1+315)	
03	DOWKER AVENUE – PLAN-PROFILE (STA. 1+315 TO END)	
04	RILEY CRESCENT – PLAN-PROFILE (START TO STA. 1+110)	
05	RILEY CRESCENT – PLAN-PROFILE (STA. 1+110 TO STA. 1+215)	
06	RILEY CRESCENT – PLAN-PROFILE (STA. 1+215 TO END)	
07	GROSVENOR AVENUE – PLAN-PROFILE (START TO STA. 1+080)	
08	GROSVENOR AVENUE – PLAN-PROFILE (STA. 1+080 TO END)	
09	GROSVENOR AVENUE – PLAN-PROFILE (START TO STA. 1+170)	

<u>Drawing No.</u>	<u>Drawing Name/Title</u>	<u>Drawing (Original) Sheet Size</u>
10	GROSVENOR AVENUE – PLAN-PROFILE (STA. 1+170 TO 1+330)	
11	GROSVENOR AVENUE – PLAN-PROFILE (STA. 1+330 TO STA. 1+490)	
12	GROSVENOR AVENUE – PLAN-PROFILE (STA. 1+490 TO STA. 1+650)	
13	GROSVENOR AVENUE – PLAN-PROFILE (STA. 1+650 TO END)	
14	GROSVENOR AVENUE – TRAFFIC CIRCLE REMOVALS	
15	NATHANIEL STREET – PLAN-PROFILE (START TO STA. 1+130)	
16	NATHANIEL STREET – PLAN-PROFILE (STA. 1+205 TO STA. 1+275)	
17	NATHANIEL STREET – PLAN-PROFILE (STA. 1+275 TO END)	
18	SYRACUSE CRESCENT – PLAN-PROFILE (START TO STA. 1+145)	
19	SYRACUSE CRESCENT – PLAN-PROFILE (STA. 1+145 TO STA. 1+305)	
20	SYRACUSE CRESCENT – PLAN-PROFILE (STA. 1+305 TO STA. 1+465)	
21	SYRACUSE CRESCENT – PLAN-PROFILE (STA. 1+465 TO END)	
22	ALLEY (ROCKWOOD-WILTON) – PLAN-PROFILE (START TO STA. 1+085)	
23	ALLEY (ROCKWOOD-WILTON) – PLAN-PROFILE (STA. 1+085 TO END)	
24	ALLEY (YALE-HARVARD) – PLAN-PROFILE	
25	SECTIONS AND DETAILS (1 OF 2)	
26	SECTIONS AND DETAILS (2 OF 2)	
27	RILEY CRESCENT – STREET LIGHTING	
28	GROSVENOR AVENUE – STREET LIGHTING	

## **E2. MOBILIZATION AND DEMOBILIZATION PAYMENT**

### DESCRIPTION

- E2.1 This Specification shall cover all operations relating to the mobilization and demobilization of the Contractor to the project location(s).
- E2.2 The Work to be done by the Contractor under this Specification shall include the furnishing of all superintendence, overhead, labour, materials, equipment, tools, supplies, and all things necessary for and incidental to the satisfactory performance and completion of all Works as hereinafter specified.
- E2.3 The inclusion of a payment item for the Work under this Specification shall not release or reduce the responsibilities of the Contractor under any other specification in this Contract.

### SCOPE OF WORK

- E2.4 Further to C12 of the General Conditions, where Mobilization and Demobilization is included as a bid item, it shall consist of the following, as applicable:
- (a) Mobilization shall include, but not be limited to:
    - (i) all activities and associated costs for transportation of the Contractor's personnel, equipment, and operating supplies to the Site, and/or Sites, and/or between Sites;
    - (ii) establishment of offices, buildings, other necessary general facilities and equipment parking/staging areas for the Contractor's operations at the Site or Sites;
    - (iii) premiums paid for performance and payment bonds including coinsurance and reinsurance agreements as applicable;
    - (iv) general cleanup and housekeeping needed maintain a neat and orderly project Site and/or Sites; and
    - (v) other job related items;
  - (b) Demobilization shall include, but not be limited to:
    - (i) all activities and costs for transportation of personnel, equipment, and supplies not used in the project from the Site, and/or Sites, and/or between Sites;
    - (ii) disassembly, removal, and Site cleanup and restoration of offices, buildings, and other facilities assembled on the Site and/or Sites;
    - (iii) repair of access roads, temporary haul roads, and equipment parking areas leaving the project Site in the same or better condition than at the start of the project; and
    - (iv) general cleanup and housekeeping needed to restore a neat and orderly project Site.
- E2.5 Access to the Site, equipment parking, and staging areas are limited to that shown on the Drawings or as approved by the Contract Administrator.

### MEASUREMENT AND PAYMENT

- E2.6 The lump-sum price for the Mobilization and Demobilization bid item shall not exceed five percent (5.00%) of the total bid price for the Contract.
- E2.6.1 Further to B9, B17, C12 and E2.6, should the lump sum price exceed five percent (5%) of the Total Bid Price the lump sum price will be reduced to five percent (5%) of the Total Bid Price, the Total Bid Price will be determined using the reduced lump sum price and payment will be based on the reduced lump sum price.
- E2.7 Payment for Mobilization:
- (a) sixty percent (60%) of the lump-sum price will be paid to the contractor for Mobilization on the first progress estimate for the Contract.
- E2.8 Payment for Demobilization:

- (a) The remaining forty percent (40%) of the lump-sum price will be paid upon:
  - (i) restoration of the Site and/or Sites to the satisfaction of the Contract Administrator;  
and
  - (ii) distribution of the declaration of Total Performance.

E2.9 Mobilization and Demobilization will be paid only once (to a maximum of one hundred percent (100%)), regardless of the number of times the Contractor mobilizes to the Site and/or Sites.

### **E3. GEOTECHNICAL REPORT**

E3.1 Further to C3.1, the geotechnical report is provided to aid the Contractor's evaluation of the pavement structure and/or existing soil conditions. The geotechnical report is contained in Appendix 'A'.

### **E4. OFFICE FACILITIES**

E4.1 The Contractor shall supply office facilities meeting the following requirements:

- (a) the field office shall be for the exclusive use of the Contract Administrator;
- (b) the building shall be conveniently located near the Site of the Work;
- (c) the building shall have a minimum floor area of twenty (20) square metres, a height of 2.4 metres with two (2) windows for cross ventilation and a door entrance with a suitable lock.
- (d) the building shall be suitable for all weather use. It shall be equipped with an electric heater and air conditioner so that the room temperature can be maintained between either sixteen (16) degrees Celsius to eighteen (18) degrees Celsius or twenty-four (24) degrees Celsius to twenty-five (25) degrees Celsius;
- (e) the building shall be adequately lighted with fluorescent fixtures and have a minimum of three (3) wall outlets;
- (f) the building shall be furnished with one (1) design table, one (1) drafting table, one (1) meeting table, one (1) stool, one (1) legal size filing cabinet, and a minimum of eight (8) chairs;
- (g) a portable toilet shall be located near the field office building. The toilet shall have a locking door and be for the exclusive use of the Contract Administrator and other personnel from the City; and
- (h) the field office building and the portable toilet shall be cleaned on a weekly basis immediately prior to each Site meeting. The Contract Administrator may request additional cleaning when he/she deems it necessary.

E4.2 The Contractor shall be responsible for all installation and removal costs, all operating costs, and the general maintenance of the office facilities.

E4.3 The office facilities will be provided from the date of the commencement of the Work to the date of Total Performance.

E4.4 On a one (1) time basis, where directed by the Contract Administrator, the Contractor shall relocate the office facilities to a location more convenient for the remaining Work.

### **E5. PROTECTION OF EXISTING TREES**

E5.1 The Contractor shall take the following precautionary steps to prevent damage from construction activities to existing boulevard trees within the limits of the construction area:

- (a) the Contractor shall not stockpile materials and soil or park vehicles and equipment on boulevards within two (2) metres of trees;



- (b) trees identified to be at risk by the Contract Administrator are to be strapped with twenty-five (25) by one hundred (100) by two thousand four hundred (2400) mm wood planks, or suitably protected as approved by the Contract Administrator;
- (c) excavation shall be performed in a manner that minimizes damage to the existing root systems. Where possible, excavation shall be carried out such that the edge of the excavation shall be a minimum of 1.5 times the diameter (measured in inches), with the outcome read in feet, from the closest edge of the trunk. Where roots must be cut to facilitate excavation, they shall be pruned neatly at the face of excavation;
- (d) operation of equipment within the dripline of the trees shall be kept to the minimum required to perform the Work required. Equipment shall not be parked, repaired, refuelled; construction materials shall not be stored, and earth materials shall not be stockpiled within the driplines of trees. The dripline of a tree shall be considered to be the ground surface directly beneath the tips of its outermost branches. The Contractor shall ensure that the operations do not cause flooding or sediment deposition on areas where trees are located; and
- (e) Work on-site shall be carried out in such a manner so as to minimize damage to existing tree branches. Where damage to branches does occur, they shall be neatly pruned.

E5.2 All damage to existing trees caused by the Contractor's activities shall be repaired to the requirements and satisfaction of the Contract Administrator and the City Forester or his/her designate.

E5.3 No separate measurement or payment will be made for the protection of trees.

E5.4 Except as required in clause E5.1(c) and E5.1(e), Elm trees shall not be pruned at any time between April 1 and July 31.

## **E6. TRAFFIC CONTROL**

E6.1 Further to clauses 3.6, 3.7 and 3.8 of CW 1130:

- (a) where directed by the Contract Administrator, the Contractor shall construct and maintain temporary asphalt ramps to alleviate vertical pavement obstructions such as manholes and planing drop-offs to the satisfaction of the Contract Administrator. Payment shall be in accordance with CW3410; and
- (b) in accordance with the Manual of Temporary Traffic Control on City Streets (MTTC), the Contractor ("Construction Agency" in the manual) shall be responsible for placing, maintaining and removing the appropriate temporary traffic control devices as specified by the MTTC or by the Traffic Management Branch of the City of Winnipeg Public Works Department. The Contractor shall bear all costs associated with the placement of temporary traffic control devices by their own forces or subcontractor.

E6.2 Notwithstanding E6.1, in accordance with the MTTC, the Contract Administrator shall make arrangements with the **Traffic Services Branch of the City of Winnipeg** to place, maintain, and remove all **regulatory signs** and traffic control devices authorized and/or required by the Traffic Management Branch in the following situations:

- (a) parking restrictions;
- (b) stopping restrictions;
- (c) turn restrictions;
- (d) diamond lane removal;
- (e) full or directional closures on a Regional Street;
- (f) traffic routed across a median;
- (g) full or directional closure of a non-regional street where there is a requirement for regulatory signs (turn restrictions, bus stop relocations, etc.) to implement the closure; and

- (h) approved Designated Construction Zones with a temporary posted speed limit reduction. Traffic Services will be responsible for placing all of the advance signs and 'Construction Ends' (TC-4) signs. The Contractor is still responsible for all other temporary traffic control including but not limited to barricades, barrels and tall cones.
- E6.2.1 An exception to E6.2 is the 'KEEP RIGHT/KEEP LEFT' sign (RB-25 / RB-25L) which shall be supplied, installed, and maintained by the Contractor at their own expense.
- E6.2.2 Further to E6.2, where the Contract Administrator has determined that the services of the Traffic Services Branch are required, the City shall bear the costs associated with the placement of temporary traffic control devices by the Traffic Services Branch of the City of Winnipeg in connection with the works undertaken by the Contractor.

## **E7. TRAFFIC MANAGEMENT**

E7.1 Further to clause 3.7 of CW 1130:

- E7.1.1 The Contractor shall schedule construction activities to meet the following:
- (a) Dowker Avenue and Riley Crescent will be closed to all traffic. The Contractor shall sign the street "Road Closed – No Exit" in accordance with the Manual of Temporary Traffic Control. The reconstruction of Dowker Avenue will be completed in two (2) phases according to the requirements of D19.1.5.
    - (i) Phase 1: Dowker Avenue from Crowson Bay to Wicklow Place; and
    - (ii) Phase 2: Dowker Avenue from Wicklow Place to South Drive;
  - (b) Grosvenor Avenue from Ash Street to Lindsay Street shall have one (1) lane for westbound traffic maintained at all times. The Contractor shall sign the street "One Way Traffic Only" in accordance with the Manual of Temporary Traffic Control. Bus access shall be maintained at the intersection of Grosvenor Avenue and Lindsay Street at all times. The Contractor shall give forty-eight (48) hour notice prior to closing the intersection with approval from the Contract Administrator;
  - (c) Nathaniel Street from Grant Avenue to Lorette Avenue shall have one (1) lane for northbound traffic maintained at all times. The Contractor shall sign the street "One Way Traffic Only" in accordance with the Manual of Temporary Traffic Control;
  - (d) Nathaniel Street from Fleet Avenue to Dudley Street will be closed to through traffic. Local access shall be maintained. The Contractor shall sign the street "Road Closed – No Exit" in accordance with the Manual of Temporary Traffic Control. All intersections and private approaches shall be maintained at all times during construction;
  - (e) Syracuse Crescent from Chancellor Drive to Chancellor Drive will be closed to through traffic. Local access shall be maintained. The Contractor shall sign the street "Road Closed – No Exit" in accordance with the Manual of Temporary Traffic Control. All intersections and private approaches shall be maintained at all times during construction;
  - (f) Grosvenor Avenue from Harrow Street to Stafford Street will be closed to all traffic. The Contractor shall sign the street "Road Closed – No Exit" in accordance with the Manual of Temporary Traffic Control. Pedestrian access to local businesses shall be maintained at all times in accordance with the Manual of Temporary Traffic Control unless approved by the Contract Administrator;
  - (g) Alley bounded by Rockwood Street/Dorchester Street/McMillan Avenue/Wilton Street will be closed to all traffic. The Contractor shall sign the street "Road Closed – No Exit" in accordance with the Manual of Temporary Traffic Control. Intersections shall be maintained at all times during construction; and
  - (h) Alley bounded by Harvard Avenue/Stafford Street/Avonherst Street/Yale Avenue will be closed to all traffic. The Contractor shall sign the street "Road Closed – No Exit" in accordance with the Manual of Temporary Traffic Control. Intersections shall be maintained at all times during construction.

E7.1.2 Should the Contractor be unable to maintain an existing access to a residence or business, he/she shall review the planned disruption with the business or residence and the Contract Administrator, and take reasonable measures to minimize the impact. The Contractor shall provide a minimum of twenty-four (24) hours notification to the affected residence or business and the Contract Administrator, prior to disruption of access.

E7.1.3 Pedestrian and ambulance/emergency vehicle access must be maintained at all times.

## **E8. REFUSE AND RECYCLING COLLECTION**

E8.1 While access to refuse and/or recycling collection vehicles is restricted, on collection day(s) the Contractor shall move all of the affected property owners refuse and/or recycling materials to a nearby common area, prior to an established time, in accordance with E8.2 to permit the normal collection vehicles to collect the materials. Immediately following recycling collection the Contractor shall return recycling receptacles to the addresses marked on the receptacles.

E8.2 Collection Schedule:

### **Dowker Avenue from Crowson Bay (East Leg to South Drive).**

*Collection Day(s):* **Wednesday**

*Collection Time:* **7:00 a.m.**

*Common Collection Area:* **Refuse and recycling from Dowker Avenue and Wicklow Place to be relocated to a common collection area as determined by the Contract Administrator.**

### **Riley Crescent from Wicklow Street to Dowker Avenue.**

*Collection Day(s):* **Wednesday**

*Collection Time:* **7:00 a.m.**

*Common Collection Area:* **Not Applicable**

### **Grosvenor Avenue from Ash Street to Lindsay Street.**

*Collection Day(s):* **Monday**

*Collection Time:* **7:00 a.m.**

*Common Collection Area:* **Not Applicable**

### **Nathaniel Street from Grant Avenue to Lorette Avenue.**

*Collection Day(s):* **Monday/Thursday**

*Collection Time:* **7:00 a.m.**

*Common Collection Area:* **Not Applicable**

### **Nathaniel Street from Fleet Avenue to Dudley Avenue.**

*Collection Day(s):* **Monday/Thursday**

*Collection Time:* **7:00 a.m.**

*Common Collection Area:* **Not Applicable**

**Syracuse Crescent from Chancellor Drive to Chancellor Drive.**

*Collection Day(s):* **Wednesday**

*Collection Time:* **7:00 a.m.**

*Common Collection Area:* **Refuse and recycling from Syracuse Crescent to be relocated to a common collection area as determined by the Contract Administrator.**

**Grosvenor Avenue from Harrow Street to Stafford Street.**

*Collection Day(s):* **Monday**

*Collection Time:* **7:00 a.m.**

*Common Collection Area:* **Not Applicable**

**Alley bounded by Rockwood Street, Dorchester Street, McMillan Avenue and Wilton Street.**

*Collection Day(s):* **Monday**

*Collection Time:* **7:00 a.m.**

*Common Collection Area:* **Refuse and recycling from Alley bounded by Rockwood Street, Dorchester Street, McMillan Avenue and Wilton Street to be relocated to the front street of each adjacent property as directed by the Contract Administrator.**

**Alley bounded by Harvard Avenue, Stafford Street, Avonherst Street and Wilton Street.**

*Collection Day(s):* **Monday**

*Collection Time:* **7:00 a.m.**

*Common Collection Area:* **Refuse and recycling from Alley bounded by Harvard Avenue, Stafford Street, Avonherst Street and Wilton Street to be relocated to the front street of each adjacent property as directed by the Contract Administrator.**

E8.3 No measurement or payment will be made for the work associated with this specification.

**E9. PEDESTRIAN SAFETY**

E9.1 During the project, a temporary snow fence shall be installed in locations such as open excavations that are adjacent to pedestrian facilities. The Contractor shall be responsible for maintaining the snow fence in a proper working condition. No measurement for payment shall be made for this Work.

**E10. WATER OBTAINED FROM THE CITY**

E10.1 Further to clause 3.7 of CW 1120, the Contractor shall pay for all costs, including sewer charges, associated with obtaining water from the City in accordance with the Waterworks and Sewer By-laws.

**E11. SURFACE RESTORATIONS**

E11.1 Further to clause 3.3 of CW 1130, when Total Performance is not achieved in the year the Contract is commenced, the Contractor shall temporarily repair any Work commenced and not completed to the satisfaction of the Contract Administrator. The Contractor shall maintain the temporary repairs in a safe condition as determined by the Contract Administrator until permanent repairs are completed. The Contractor shall bear all costs associated with temporary repairs and their maintenance.

## **E12. INFRASTRUCTURE SIGNS**

E12.1 The Contractor shall obtain infrastructure signs from the Traffic Services Sign Shop at 421 Osborne Street. The Contractor shall mount each sign securely to a rigid backing material approved by the Contract Administrator. The Contractor shall fasten each sign to a suitable support and erect and maintain one (1) sign at each street as directed by the Contract Administrator. When the Contract Administrator considers the Work on the street complete, the Contractor shall remove and dispose of the signs and supports. No measurement for payment will be made for performing all operations herein described and all other items incidental to the work described

## **E13. SUPPLY AND INSTALLATION OF PAVEMENT REPAIR FABRIC**

### DESCRIPTION

E13.1 General

E13.1.1 This specification covers the supply and installation of pavement repair fabric for reinforcement of asphalt layers and is contained in Appendix 'H'.

## **E14. PARTIAL DEPTH PATCHING OF EXISTING JOINTS**

### DESCRIPTION

E14.1 General

E14.1.1 This specification covers the Partial Depth Patching of existing concrete pavement joints.

E14.2 Referenced Standard Construction Specifications:

- (a) CW 3230 – Full-Depth Patching of Existing Slabs and Joints; and
- (b) CW 3410 – Asphalt Concrete Pavement Works.

### MATERIALS

E14.3 Asphalt Materials

E14.3.1 Asphalt material will be Type 1A supplied in accordance with Sections 5 and 6 of CW 3410.

E14.4 Tack Coat

E14.4.1 Tack Coat will be undiluted SS-1 emulsified asphalt.

### CONSTRUCTION METHODS

E14.5 Planing of Joints

E14.5.1 Plane existing joints designated by the Contract Administrator to a minimum depth of fifty (50) mm and a maximum of depth ninety (90) mm to remove ravelled or deteriorated concrete. Width of joint to be planed will vary with depth.

E14.5.2 Should the depth of joint deterioration exceed the maximum indicated, as determined by the Contract Administrator, the entire joint shall be renewed and paid for in accordance with CW 3230 as a full depth joint repair. Planing completed shall be paid for in accordance with Section 4 of CW 3450.

E14.5.3 Dispose of material in accordance with Section 3.4 of CW 1130.

E14.6 Placement of Asphalt Material

E14.6.1 Prior to placement of asphalt material, the planed joint shall be swept or blow clean of any loose material.

- E14.6.2 Apply Tack Coat uniformly on the entire surface of the planed joint. The application rate shall not exceed 0.23 litres per square metre. The planed joint shall be dry prior to applying the tack coat.
- E14.6.3 Place and compact asphalt material in accordance with Section 9.3 of CW 3410 to the satisfaction of the Contract Administrator. The finished elevation of the patch shall be flush with surrounding pavement surface.
- E14.6.4 Compact the asphalt material to an average ninety-five percent (95%) of the 75 blow Marshall Density of the paving mixture with no individual test being less than ninety percent (90%).
- E14.6.5 Ensure that no traffic is allowed to travel over the patched area until the asphalt has cooled to atmospheric temperature.

#### MEASUREMENT AND PAYMENT

- E14.7 Partial Depth Planing of Existing Joints
- E14.7.1 Partial Depth Planing of Existing Joints will be measured on an area basis and paid for at the Contract Unit Price per square metre for "Partial Depth Planing of Existing Joints". The area to be paid for will be the total number of square metres of joints planed in accordance with this specification, accepted and measured by the Contract Administrator.
- E14.8 Asphalt Patching of Partial Depth Joints
- E14.9 Asphalt Patching of Partial Depth Joints will be measured on an area basis and paid for at the Contract Unit Price per square metre for "Asphalt Patching of Partial Depth Joints". The area to be paid for will be the total number of square metres of joints patched in accordance with this specification, accepted, and measured by the Contract Administrator.

### **E15. ASPHALT PATCHING OF MISCELLANEOUS CONCRETE**

#### DESCRIPTION

- E15.1 General
- E15.1.1 This specification covers the placement of asphalt patches in various situations to prepare a concrete pavement for subsequent placement of mainline asphalt pavement overlay. This includes patching full depth concrete repairs, cracks and joints, and vertical faults.
- E15.2 Referenced Standard Construction Specifications:
- (a) CW 1130-R2 - Site Requirements;
  - (b) CW 3250-R7 – Joint and Crack Maintenance; and
  - (c) CW 3410-R10 – Asphaltic Concrete Pavement Works.

#### MATERIALS AND EQUIPMENT

- E15.3 Asphalt Materials
- E15.3.1 Asphalt material supplied shall be as per CW 3250 (Type 1 Asphalt Material).
- E15.4 Equipment
- E15.4.1 Equipment as per CW 3410-R10 Clause 8.

#### CONSTRUCTION METHODS

- E15.5 Full Depth Concrete Repairs
- E15.5.1 Place asphaltic concrete over the newly constructed joint repair where there is a minimum of twenty (20) mm elevation difference between repair surface and adjacent pavement

surface. Remove any loose or debonded asphalt at the joint perimeter and place new asphaltic concrete in these areas as well.

- E15.5.2 Dispose of all material in accordance with Section 3.4 of CW 1130-R2.
  - E15.5.3 Prior to placement of asphaltic concrete patching material, ensure surface is clean and dry.
  - E15.5.4 Prepare the joint surface with a uniform application of Tack Coat applied in small quantities sufficient to wet the concrete surface.
  - E15.5.5 Place and compact asphaltic concrete over the joint repair in accordance with CW 3410-R8 Clause 9.3 and to the satisfaction of the Contract Administrator so that the finished elevation of the patch is flush with surrounding asphalt surface.
  - E15.5.6 Compact the asphalt material to an average ninety-five percent (95%) of the 75 blow Marshall Density of the paving mixture with no individual test being less than ninety percent (90%).
  - E15.5.7 Ensure that no traffic is allowed to cross the patched area until the asphalt has cooled to atmospheric temperature.
- E15.6 Crack/Joint Patching
- E15.6.1 Construction Methods as per CW 3250-R7 Clause 3.4.

#### MEASUREMENT AND PAYMENT

- E15.7 Asphalt Patching of Miscellaneous Concrete will be measured on an area basis and paid for at the Contract Unit Price per square metre for "Asphalt Patching of Miscellaneous Concrete". The area to be paid for will be the total number of square metres of full depth joints, cracks and joints, and vertical faults patched in accordance with this specification, accepted, and measured by the Contract Administrator.

### **E16. SALT TOLERANT GRASS SEEDING**

#### DESCRIPTION

- E16.1 Further to CW 3520 and CW 3540, this specification shall cover sub-grade preparation and the supply and placement of Salt Tolerant Grass Seed.

#### MATERIALS

- E16.2 Salt Tolerant Grass Seed
  - E16.2.1 Salt Tolerant Grass Seed for regional and collector boulevards, medians and interchange areas shall be a mixture composed of:
    - (a) seventy percent (70%) Fults or Nuttals Alkaligrass (*Puccinellia* spp.), twenty percent (20%) Audubon or Aberdeen Creeping Red Fescue and ten percent (10%) Perennial Ryegrass.

#### EQUIPMENT

- E16.3 Scarification equipment shall be suitable for the area being scarified, shall be capable of scarifying the sub-grade to the specified depth and shall be accepted by the Contract Administrator. For confined areas a toothed bucket may be acceptable. For larger areas tilling equipment may be required.

#### CONSTRUCTION METHODS

- E16.4 Preparation of Existing Grade
  - E16.4.1 Prior to placing topsoil, in areas to be seeded greater in width than six hundred (600) mm, prepare the existing sub-grade by scarifying to a minimum depth of seventy-five (75) mm

and to a maximum depth of one hundred (100) mm to the satisfaction of the Contract Administrator.

E16.4.2 Scarification shall consist of breaking up and loosening the sub-grade. No scarification shall occur within the edge of a tree canopy (or drip line).

E16.5 Salt Tolerant Grass Seeding

E16.5.1 Salt Tolerant Grass Seed shall be sown at a rate of 2.2 kilograms per one hundred (100) square meters.

#### MEASUREMENT AND PAYMENT

E16.6 Supply, placement and maintenance of Salt Tolerant Grass Seed will be paid for at the Contract Unit Price per square metre for "Salt Tolerant Grass Seeding", measured as specified herein, which price shall be payment in full for supplying all materials and for completing all operations herein described and all other items incidental to the Work included in this Specification. Payment for Salt Tolerant Grass Seeding shall be in accordance with the following:

- (a) sixty five percent (65%) of quantity following supply and placement; and
- (b) remaining thirty five percent (35%) of quantity following termination of the Maintenance Period.

### **E17. SUPPLY AND INSTALL WATERMAIN AND WATER SERVICE INSULATION**

#### DESCRIPTION

E17.1 Notwithstanding 3.12 of CW 2110, this specification covers the supply and installation of insulation in roadway excavations over watermains and water services.

E17.2 Referenced Standard Construction Specifications:

- (a) CW 2030 – Excavation Bedding and Backfill; and
- (b) CW 3110 – Sub –grade, Sub-base and Base Course Construction.

E17.3 Referenced Standard Details:

- (a) SD-018 - Watermain and Water Service Insulation.

#### MATERIALS

E17.4 Acceptable insulation is:

- (a) Extruded Polystyrene rigid foam insulation – Type 4, 101.6 mm (four (4) inches) in thickness.

DOW - Roofmate or Highload 40

Owen's Corning - Foamular 350 or Foamular 400.

50.8 mm (two (2) inches) by 1219.2 mm (forty-eight (48) inches) by 2438.4 mm (ninety-six (96) inches), 50.8 mm (two (2) inches) by 609.6 mm (twenty-four (24) inches) by 2438.4 mm (ninety-six (96) inches), 101.6 mm (four (4) inches) by 609.6 mm (twenty-four (24) inches) by 2438.4 mm (ninety-six (96) inches).

E17.5 Sand Bedding:

- (a) In accordance with CW 2030.

#### CONSTRUCTION METHODS

E17.6 Prior to the installation of any sub-base material or geotextile material, locate all existing water services. Further to SD-018, where directed by the Contract Administrator, excavate the sub-grade to allow the top of the insulation to be installed flush with the surrounding sub-grade. Install the insulation on a level surface centered over the located watermain or water service for



the full width of the roadway excavation. Install sand bedding if required to level the surface. Stockpile and dispose of excavated material in accordance with CW 3110.

- E17.7 Thickness of insulation is one hundred (100) mm (four (4) inches). If using fifty (50) mm (two (2) inches) panels two (2) layers are required. Total width of insulation to be as directed by the Contract Administrator. Place sufficient full width panels to meet or exceed the specified width.
- E17.8 Place insulation panels adjacent to each other over the specified area with no gaps between panels and less than fifteen (15) mm of elevation difference along the adjoined edges. Where fifty (50) mm (two (2) inches) thick panels are being used, offset the top layer to prevent the panel joints from aligning with the joints in the lower layer.
- E17.9 Use full panels of insulation where possible. Where necessary cut insulation panels to obtain coverage to specified lengths. Insulation pieces shall be a minimum of dimension of three hundred (300) mm in width or length.
- E17.10 Take appropriate measures to ensure panels are not displaced when installing geotextiles and during backfilling operations.

#### MEASUREMENT AND PAYMENT

- E17.11 Watermain and Water Service Insulation shall be measured on an area basis and paid for at the Contract Unit Price per square metre of "Watermain and Water Service Insulation". The area to be paid for shall be the total square meters of watermain and water service insulation supplied and installed in accordance with this specification, accepted and measured by the Contract Administrator.
- (a) Excavation of the roadway subgrade in accordance with E17.6 will not be measured for payment and will be included in the payment for "Watermain and Water Service Insulation".

### **E18. REPLACE MANHOLE BENCHING**

#### DESCRIPTION

- E18.1 This Specification covers the placement of benching in existing manholes.

#### CONSTRUCTION METHODS

- E18.2 Replace Manhole Benching:
- (a) the Contractor shall remove and dispose of existing loose or crumbling benching mortar to the satisfaction of the Contract Administrator; and
- (b) the Contractor shall bench and channel the manhole floor with mortar or concrete in accordance with CW 2130, SD-010 and SD-011. Flow channels shall curve smoothly and provide a smooth transition between inlet and outlet pipes.

#### MEASUREMENT AND PAYMENT

- E18.3 Replacement of manhole benching will be measured on a unit basis and paid for at the Contract Unit Price for "Replace Manhole Benching". The number to be paid for shall be the total number of manholes that have been repaired in accordance with this Specification, accepted and measured by the Contract Administrator.

### **E19. CURB AND GUTTER VARIOUS FORMATS**

#### DESCRIPTION

- E19.1 General
- E19.1.1 This specification covers the Work related to the installation of seventy-five (75) mm Lip Curb and Gutter, forty (40) mm Lip Curb and Gutter, and Modified Barrier Curb and Gutter.

E19.2 Referenced Standard Construction Specifications:  
(a) CW 3310 – Portland Cement Concrete Pavement Works.

E19.3 Referenced Standard Details and Drawings:  
(a) seventy-five (75) mm Lip Curb – SD-202A;  
(b) forty (40) mm Lip Curb – SD-202B;  
(c) Modified Barrier Curb – SD-203B; and  
(d) all applicable Contract Drawings.

#### MATERIALS AND EQUIPMENT

E19.4 Materials

E19.4.1 Materials supplied shall be as per CW 3310 Clause 5.

E19.5 Equipment

E19.5.1 Equipment as per CW 3310 Clause 8.

#### CONSTRUCTION METHODS

E19.6 Seventy-five (75) mm Lip Curb and Gutter

E19.6.1 Seventy-five (75) mm Lip Curb and Gutter shall be constructed where specified using the SD-202A shape for the curb, and the Contract Drawings for the gutter width and height. Unless directed by the Contract Administrator, the curb and gutter shall be slip formed.

E19.7 Forty (40) mm Lip Curb and Gutter

E19.7.1 Forty (40) mm Lip Curb and Gutter shall be constructed where specified using the SD-202B shape for the curb, and the Contract Drawings for the gutter width and height. Unless directed by the Contract Administrator, the curb and gutter shall be slip formed.

E19.8 Modified Barrier Curb and Gutter

E19.8.1 Modified Barrier Curb and Gutter shall be constructed where specified using the SD-203B shape for the curb, and the Contract Drawings for the gutter width and height. Unless directed by the Contract Administrator, the curb and gutter shall be slip formed.

E19.9 Where directed by the Contract Administrator to be hand formed, the Contractor shall use wood forms and templates to ensure the curb is shaped properly. Wood forms and templates shall be constructed to allow for the placement of curb and gutter in unison to ensure adhesion of the integral curb.

E19.10 Sawcut all curb and gutter types transversely every three (3) metres.

E19.11 Transitions between curb and gutter types as per Contract Drawings.

#### MEASUREMENT AND PAYMENT

E19.12 Curb and Gutter – Various Formats

E19.12.1 Construction of seventy-five (75) mm Lip Curb and Gutter, forty (40) mm Lip Curb and Gutter, and Modified Barrier Curb and Gutter will be measured on a length basis and will be paid for at the Contract Unit Price per metre for the “Concrete Curbs, Curb and Gutter, and Splash Strips” items below, measured as specified herein, which price shall be payment in full for performing all operations herein described and all other items incidental to the Work included in the specification.

E19.12.2 Transitions between curb and gutter types will be paid for at the more costly Contract Unit Price of the two (2) curb and gutter types.

- (a) Concrete Curbs, Curb and Gutter, and Splash Strips:
  - (i) construction of seventy-five (75) mm Lip Curb and Gutter;
  - (ii) construction of forty (40) mm Lip Curb and Gutter; and
  - (iii) construction of Modified Barrier Curb and Gutter.

## **E20. CONSTRUCTION OF BARRIER CURB FOR ASPHALT PAVEMENT**

### DESCRIPTION

- E20.1 This Specification covers the construction of Barrier Curb on Grosvenor Avenue where the underlying concrete pavement may be rubbelized in localized areas. This may prevent the construction of new concrete pavement tying into the rubbelized sections. Instead, an asphalt pavement structure will be constructed and a Barrier Curb pinned in place.
- E20.2 Referenced Standard Construction Specifications and Standard Detail Drawings:
  - (a) CW 3110 – Sub-grade, Sub-base and Base Course Construction;
  - (b) CW3310 – Portland Cement Concrete Pavement Works;
  - (c) CW 3240 – Renewal of Existing Curbs; and
  - (d) Standard Detail Drawings SD-200A and SD-200B.

### CONSTRUCTION METHODS

- E20.3 Construction of Barrier Curb for Asphalt Pavement
  - (a) place and compact base course material for roadway in accordance with Specification CW3110;
  - (b) supply and install tie-bars, dowels, and deformed bars as shown on Detail 4 of the Contract Drawings; and
  - (c) provide a minimum of forty (40) mm cover between reinforcing steel and the finished concrete surface.
- E20.4 Transverse joints will be saw cut every three (3.0) metres. Transverse joints are to be sawn to a maximum depth of twenty-five (25) mm, so as not to saw cut into the 10M longitudinal deformed bars and 19.1 mm dowels.
- E20.5 Place and compact base course material as backfill behind barrier curb for asphalt pavement within excavated area approximately one hundred fifty (150) mm deep or as directed by the Contract Administrator. Place and compact suitable Site material as backfill behind barrier curb or modified barrier curb to allow for one hundred (100) mm of topsoil and sod below the top of curb. Care must be taken so as not to disturb the barrier curb for asphalt pavement during placing and compaction of base course material and suitable Site materials.

### MEASUREMENT AND PAYMENT

- E20.6 Construction of Barrier Curb for Asphalt Pavement shall be measured on a length basis and paid for at the Contract Unit Price per metre of "Construction of Barrier Curb for Asphalt Pavement". The length to be paid for shall be the total number of meters supplied and installed in accordance with this Specifications, accepted and measured by the Contract Administrator.
- E20.7 The supply and installation of reinforcing steel, base course for backfill, and suitable Site material is incidental to "Construction of Barrier Curb for Asphalt Pavement and no measurement or payment will be made.

## **E21. PORTLAND CEMENT CONCRETE SIDEWALK WITH BLOCK OUTS FOR INDICATOR SURFACES**

### DESCRIPTION

E21.1 This specification shall supplement CW 3325-R5 "Portland Cement Concrete Sidewalks".

### CONSTRUCTION METHODS

E21.2 Add the following to CW 3325-R5 Section 9:

E21.2.1 As shown on the Drawings and as directed by the Contract Administrator, construct sidewalk with block outs and/or monolithic curb and sidewalk with block outs, to allow for the installation of indicator surfaces.

E21.2.2 Verify dimensions of paving stones (indicator surface) prior to construction of the block-outs. Gaps between paving stones and concrete pavement shall not exceed five (5) mm.

E21.2.3 Concrete curbs for monolithic curb and sidewalk with block outs shall be constructed in accordance with CW 3240.

### MEASUREMENT AND PAYMENT

E21.3 Add the following to CW 3325-R5 Section 12:

E21.3.1 Construction of concrete sidewalks with block outs for indicator surfaces will be measured on surface area basis. The surface area to be paid for shall be the number of square metres constructed in accordance with this specification and accepted by the Contract Administrator, as computed by measurements made by the Contract Administrator.

### BASIS OF PAYMENT

E21.4 Add the following to CW 3325-R5 Section 13:

E21.4.1 Construction of concrete sidewalks with block outs for indicator surfaces will be paid for at the Contract Unit Price per square metre for the "Items of Work" listed here below (E21.4.2), measured as specified herein, which price shall be payment in full for supplying all materials and for performing all operations herein described and all other items incidental to the Work included in this specification.

E21.4.2 Items of Work:

(a) Monolithic curb and one hundred fifty (150) mm sidewalk with block outs.

E21.4.3 Concrete thickness greater than the specified sidewalk thickness as a result of shaping the base material to accommodate the block outs is incidental to the listed E21.4.2.

## **E22. PAVING STONES FOR INDICATOR SURFACES**

### DESCRIPTION

E22.1 This specification shall supplement CW 3330-R5 "Installation of Interlocking Paving Stones".

### MATERIALS

E22.2 Add the following to CW 3330-R5 Section 5:

E22.2.1 Paving stones for indicator surfaces shall be as shown on the Drawings.

E22.2.2 Paving stones for indicator surfaces shall be :

(a) Barkman Concrete paving stones – Blue Holland Paver (sixty (60) mm by two hundred ten (210) mm by two hundred ten (210) mm)

<https://www.barkmanconcrete.com/>.

## CONSTRUCTION METHODS

- E22.3 Add the following to CW 3330-R5 Section 9.2 "Preparation of Sub-grade, Sub-base and Sand-base":
- E22.3.1 Preparation of "Sand-Base for Paving Stones in Sidewalk Block Outs".
  - E22.3.2 Place a fifteen (15) mm layer of bedding sand in the blocked out sidewalk areas.
  - E22.3.3 The bedding sand shall be spread and levelled so that the paving stones when installed are five (5) mm higher than the finished grade.
  - E22.3.4 No more sand shall be spread than can be covered in with paving stone on the same day.
  - E22.3.5 The bedding sand shall not be compacted or disturbed prior to laying the paving stones.
- E22.4 Add the following to CW 3330-R5 Section 9.3 "Installation of Paving Stones":
- E22.4.1 For indicator surface paving stones, commence installation of paving stones against the long edge of the block out to obtain the straightest possible course of installation.

## MEASUREMENT AND PAYMENT

- E22.5 Add the following to CW 3330-R5 Section 12:
- E22.6 Supply and Installation of Paving Stones for Indicator Surfaces
- E22.6.1 Paving stones for indicator surfaces will be measured on surface area basis. The surface area to be paid for shall be the number of square metres constructed in accordance with this specification and accepted by the Contract Administrator, as computed by measurements made by the Contract Administrator.

## BASIS OF PAYMENT

- E22.7 Add the following to CW 3330-R5 Section 13:
- E22.7.1 The supply and installation of paving stones for indicator surfaces will be paid for at the Contract Unit Price per square metre for "Paving Stone Indicator Surface", measured as specified herein, which price shall be payment in full for supplying all materials and for performing all operations herein described and all other items incidental to the Work included in this specification.
  - E22.7.2 Concrete thickness greater than the specified sidewalk thickness as a result of shaping the base material to accommodate the block outs is incidental to the listed Items of Work.

## **E23. BIDDING INSTRUCTIONS FOR LIMESTONE AND/OR RECYCLED BASE COURSE AND SUB-BASE MATERIALS**

### DESCRIPTION

- E23.1 This specification covers the bidding instructions for Granular B Interim Recycled Concrete Sub-base Materials.
- E23.2 Referenced Standard Construction Specifications and Standard Detail Drawings:
  - (a) CW 3110 – Sub-grade, Sub-base and Base Course Construction.

### MATERIALS

- E23.3 Add the following to Table CW 3110.2 Physical Property Requirements from CW 3110-R21 Section 2.2 "Base Course and Sub-Base Materials" for physical property requirements specific to Granular B Interim Recycled Concrete Sub-base materials:

Tests	Testing Method	Interim Granular B	
		50 mm	100 mm
Los Angeles Abrasion, (% maximum)	ASTM C535 (Grading 1)	--	35
Los Angeles Abrasion, (% maximum)	ASTM C131 (Grading A)	35	--
California Bearing Ratio (CBR) - 4 days soaked, (% minimum at 2.54 mm)	ASTM D1883	50	--
Micro-Deval Abrasion, (% maximum)	ASTM D6928	20	20
Percentage of Fractured Particles, minimum two or more fractured faces, (% mass)	ASTM D5821	70	60
Atterberg Limits* (Liquid Limit,% maximum) (Plasticity Index,% maximum)	ASTM D4318	22 4	25 6
Content Composition, (maximum)	Mass %	10% asphalt material 3% clay 3% deleterious materials	

#### METHOD

- E23.4 Place and compact Granular B Interim Recycled Concrete Sub-base Materials as per Section 3.3, 3.4, and 3.5 of CW 3110.
- E23.4.1 A Bidder must Bid on a combination of A.2 and A.5 i), or A.3 and A.5 ii) on Form B: Prices but not both.
- E23.4.2 A Bidder must Bid on a combination of B.1 and B.4 i), or B.2 and B.4 ii) on Form B: Prices but not both.
- E23.4.3 A Bidder must Bid on a combination of G.2, G.5 i), G.5 iii) and G.17, or G.3, G.5 ii), G.5 iv), and G.18 but not both.
- E23.4.4 A Bidder must Bid on a combination of H.1, H.4 i), and H.8 i), or H.2, H.4 ii), and H.8 ii) but not both.
- E23.4.5 A Bidder must Bid on a combination of I.1, I.4 i), and I.8 i), or I.2, I.4 ii), and I.8 ii) but not both.

#### MEASUREMENT AND PAYMENT

- E23.5 The supplying, placing and compaction of sub-base material will be measured on a weight basis and paid for at the Contract Unit Price per tonne for the "Supplying and Placing Sub-base Material" listed here below. The weight to be paid for will be the total number of tonnes of subbase material supplied and placed in accordance with this specification, accepted by the Contract Administrator.
- (a) Items of Work:
- (i) fifty (50) mm Granular B Interim Recycled Concrete Sub-base; and
  - (ii) one hundred (100) mm Granular B Interim Recycled Concrete Sub-base.
- E23.6 The weight to be paid for will be the total number of tonnes of sub-base material as measured on a certified weigh scale.
- E23.7 Only material placed within the limits of excavation will be included in the payment for the "Items of Work" listed for sub-base material.

E23.8 No measurement or payment will be made for materials rejected by the Contract Administrator.

**E24. WORKING AROUND TERASPAN FIBRE OPTIC LINES**

E24.1 The Contractor is not responsible to protect or restore any Teraspan fibre optic lines that must be removed during normal construction practices.

E24.2 The Contractor shall not remove any portion of a Teraspan fibre optic line before receiving written approval from the Contract Administrator.

**E25. OPERATING CONSTRAINTS FOR WORK IN CLOSE PROXIMITY TO CRITICAL WATER INFRASTRUCTURE**

DESCRIPTION

E25.1 This Section details operating constraints for all work to be carried out in close proximity to the City feeder mains and other critical water infrastructure. Close proximity shall be deemed to be any construction activity within a five (5) metres horizontal offset from the centreline of the feeder main/water main, within five (5) metres of valve chambers and other appurtenances, and any other infrastructure identified below.

E25.2 The feeder main beneath Waverley Street shall be considered a component of critical pipelines and water infrastructure for this project. The feeder main runs north-south within Waverley Street right of way as shown on the Drawings.

E25.3 General Considerations for Work in Close Proximity to Critical Water Infrastructure:

E25.3.1 Feeder mains and large diameter water mains are a critical component of the City of Winnipeg Regional Water Supply System and Work in close proximity to feeder mains shall be undertaken with an abundance of caution. Large diameter feeder main and water mains cannot typically be taken out of service for extended periods to facilitate construction and inadvertent damage caused to the pipe would likely have catastrophic consequences.

E25.3.2 Work around critical water infrastructure shall be planned and implemented to minimize the time period that Work is carried out in close proximity to the pipe and to ensure that the pipeline is not subjected to excessive construction related loads, including excessive vibrations and/or concentrated or asymmetrical lateral loads during backfill placement.

E25.3.3 Large diameter pressure pipe generally has limited ability to withstand increased earth and live loading. Therefore, every precaution must be undertaken to ensure that applied loading during all phases of construction is within accepted loading parameters. PCCP typically fails in a non-ductile mode with the potential to cause extensive consequential damage to infrastructure if failure should occur. All large diameter feeder mains/water mains have the potential to cause extensive flooding.

E25.3.4 Construction in close proximity to critical infrastructure shall not commence until both the equipment and construction method statements have been submitted, reviewed, and accepted by the Contract Administrator.

E25.4 Submittals

E25.4.1 Submit proposed construction equipment specifications to the Contract Administrator for review a minimum of five (5) Business Days prior to construction. The equipment submission shall include:

- (a) equipment operating and payload weights;
- (b) equipment dimensions, including: wheel or track base, track length or axle spacing;
- (c) track widths or wheel configurations; and
- (d) load distributions in the intended operating configuration.

- E25.4.2 Submit a construction method statement to the Contract Administrator a minimum of five (5) Business Days prior to construction. The construction method statement shall contain the following minimum information:
- (a) proposed construction plan including excavation locations, haul routes, excavation equipment locations, and loading positions;
  - (b) excavation plans, including shoring designs, for excavations occurring in close proximity to feeder mains (within five (5) metres horizontal of the pipe's centerline) where the excavation to be extended below the top of the feeder mains embedment zone (one hundred fifty (150) mm above the pipe);
  - (c) trenchless construction methodology for feeder main crossings, including: installation methods, means of grade control, means of confirming clear separation between the new LDS and existing feeder main; and
  - (d) any other pertinent information required to accurately describe the construction activities in close proximity to the feeder main and permit the Contract Administrator to review the proposed construction plans.
- E25.4.3 Incomplete or partial submissions will not be reviewed and will be returned to the Contractor for re-submission.
- E25.4.4 Allow five (5) Business Days for review by the Contract Administrator.
- E25.5 Feeder Main Operational Limitations
- E25.5.1 Feeder main shutdowns are scheduled based on a number of factors including water demand, weather, reservoir operation, routine maintenance and repair work within the regional distribution system, and other factors. If feeder main shutdowns are required, the City shall endeavour to make requested time periods available to the Contractor to schedule his/her work requiring removal of the feeder main from service, without limiting the City's control over the operation of the feeder main to complete other work, maintain adequate water supply and storage of water and maintain the integrity of the infrastructure. The City shall reserve the right to cancel and/or delay these schedule dates at any time, due to any circumstances that could adversely affect the feeder main or water supply including, but not limited to, high water demand, abnormal weather, failures of related water system components and/or security concerns.
- E25.5.2 Scheduling Restrictions:
- (a) Temporary feeder main shutdowns are typically limited to off-peak demand seasons (September 15 to May 15) and low demand hours including evenings or other low demand periods.
- E25.5.3 The Contractor shall provide Notice to the Contract Administrator in writing, a minimum of fifteen (15) Business Days prior to requiring the shutdown. The City will endeavour to schedule the shutdown as requested.
- E25.6 Pre-Work, Planning and General Execution
- E25.6.1 No Work shall commence in close proximity to feeder mains, chambers, and critical infrastructure until the equipment specifications and construction method statement have been submitted and accepted, and feeder main locations have been clearly delineated in the field. Work over feeder mains shall only be carried out with equipment that has been reviewed and quantified in terms of its loading implications on the pipe.
- E25.6.2 Contact the City of Winnipeg Water and Waste Department, Construction Services Coordinator prior to construction.
- E25.6.3 Locate feeder mains and watermains and confirm their position horizontally and vertically at the proposed the following locations prior to undertaking Work in close proximity to the identified feeder mains. Note, exact locations to be identified in the field. Deviations from the elevations noted on the Drawings shall be reported to Contract Administrator for review prior to proceeding with Work:



- (a) The feeder main beneath the intersection of Waverley Street and Grosvenor Avenue.
- E25.6.4 Visually delineate all critical infrastructure identified herein on Site by use of paint, staking/flagging, construction fencing, snow fencing, or other suitable methods.
- E25.6.5 Only utilize construction practices and procedures that do not impart excessive vibratory loads on feeder mains and chambers or that would cause settlement of the subgrade below feeder mains and critical pipelines.
- E25.6.6 Where the existing road structure must be removed, crossing of critical infrastructure shall be prohibited from the time the existing roadway structure is removed until the completion of granular base construction. At all times prior to completion of final paving; reduce equipment speeds to levels that minimize the effects of impact loading to the critical infrastructure.
- E25.6.7 Only equipment and construction practices stipulated in the accepted construction method statement and the supplemental requirements noted herein may be utilized in close proximity to feeder mains, chambers, and other critical infrastructure identified herein.
- E25.6.8 Construction operations should be staged in such a manner as to limit multiple construction loads at one (1) time, (e.g., offset crossings sufficiently from each other, rollers should remain a sufficient distance behind spreaders to limit loads. A reasonable offset distance is three (3) metres between loads).
- E25.6.9 Granular material, construction material, soil, and/or other material shall not be stockpiled on the pipelines or within five (5) metres of any feeder main, valve chamber, or other critical infrastructure identified herein.
- E25.6.10 The Contractor shall ensure that all crew members understand and observe the requirements of working near feeder mains, valve chambers, and critical infrastructure. Prior to commencement of on-Site work, the Contractor shall jointly conduct an orientation meeting with the Contract Administrator, all superintendents, foreman, and heavy equipment operators to make all workers on the Site fully cognizant of the limitations of altered loading on, the ramifications of inadvertent damage to, and the constraints associated with Work in close proximity to feeder mains and critical pipelines. New personnel introduced after commencement of the Project need to be formally orientated as outlined herein. It is recommended that restrictions associated with the crossing, consistent with the Contractor's submitted method statement be posted on Site and near the crossing.
- E25.7 Demolition, Excavation and Shoring
- E25.7.1 Use of pneumatic concrete breakers within three (3) metres of a feeder main, valve chamber, or critical pipeline is prohibited. Pavement shall be full depth sawcut and carefully removed. Use of hand held jackhammers for pavement removal will be allowed.
- E25.7.2 Offset excavation equipment a minimum of three (3) metres from the centerline of critical pipelines when undertaking excavations where there is less than 2.4 metres of earth cover over the pipeline.
- E25.8 Excavation:
- (a) Utilize only smooth edged excavation buckets, soft excavation, or hand excavation techniques where there is less than 1.5 metres of earth cover over the pipeline.
  - (b) Where there is less than one (1.0) metres of soil cover above the pipeline, provide full time supervision and complete the excavation utilizing hand excavation, soft excavation methods, or machine excavation. Where machine excavation is to be used the crown of the pipeline must be exposed (or suitable located) using hand or soft excavation methods a minimum of every 1.8 metres.
  - (c) Where there is less than 0.5 metres of soil cover above the pipeline, provide full time supervision and complete the excavation utilizing hand excavation or soft excavation methods only.

- E25.8.1 Equipment should not be allowed to operate while positioned directly over a feeder main or critical pipeline except where permitted herein, outlined in the reviewed and accepted construction method statement.
- E25.8.2 Excavations within three (3) metres of the outside edge of a feeder main (hydrovac holes for confirming trenchless installations excluded) and which extend below the surface of the feeder main shall utilize shoring methods that preclude the movement of native in-situ soils (i.e. a tight shoring system).
- E25.8.3 Excavation and base placement for sidewalks and approaches shall be completed and shall be completed remotely with limitations as specified herein.
- E25.9 Underground Construction and Trenchless Pipe Installation
- E25.9.1 Where removing existing catch basins are noted on the Drawings, expose feeder main where catch basin is closer than three (3) metres from Feeder Main. Where Contract Administrator determines removal of catch basin may undermine pipe foundation, remove catch basin to the top of the feeder main and abandon catch basin in place.
- E25.9.2 Where excavation is required within the feeder main's embedment zone, the Contractor shall take steps to ensure the granular embedment material surrounding the feeder main remains stable during the work and the feeder main outside of the excavation is not undermined.
- E25.10 Subgrade Construction
- E25.10.1 Subgrade and backfill compaction within three (3) metres (horizontal) of a critical pipeline or valve chamber shall be limited to non-vibratory methods only. Small walk behind vibratory packers will be permitted.
- E25.10.2 Subgrade, sub-base and base course construction shall be kept in a rut free condition at all times. Construction equipment is prohibited from crossing pipelines if the grade is insufficient to support the equipment without rutting.
- E25.10.3 Subgrade conditions should be inspected by personnel with competent geotechnical experience (e.g. ability to adequately visually classify soils and competency of subgrade, subbase, and base course materials). In the event of encountering unsuitable subgrade materials above the feeder main, proposed design revisions shall be submitted to this office for review to obtain approval from the Water and Waste Department relative to any change in conditions.
- E25.10.4 Fill material shall not be dumped directly on pipelines but shall be stockpiled outside the limits noted in these recommendations and shall be carefully bladed in-place.
- E25.10.5 Only use compaction equipment approved by the Contract Administrator to compact fill materials above critical pipelines. Compaction of fill materials shall be completed using static methods only, no vibratory compaction will be allowed within the limits noted in these recommendations.
- E25.10.6 Construction operations shall be staged to minimize the time period between excavation to subgrade and placement of granular subbase materials. Should bare subgrade be left overnight, measures shall be implemented to protect the subgrade against inadvertent travel over it and to minimize the impact of wet weather.
- E25.11 Subbase and Base Course Construction
- E25.11.1 Subbase or base course materials shall not be dumped directly on pipelines but shall be stockpiled outside limits noted in these recommendations and shall be carefully bladed in-place.
- E25.11.2 Subbase compaction within three (3) metres horizontal of the centreline of a critical pipeline shall be either carried out by static methods (without vibration) or with smaller approved equipment such as hand held plate packers or smaller roller equipment.

## E25.12 Paving

- E25.12.1 When constructing asphalt pavements only non-vibratory compaction should be used within three (3) metres (horizontal) of the center of critical pipelines.

## E26. INSTALLATION OF STREET LIGHTING AND ASSOCIATED WORKS

### DEFINITIONS

- E26.1 "**Limits of Approach**" means the shortest distance that is permissible between live high voltage (greater than seven hundred fifty (750) volts) conductors or apparatus and any part of a worker's body, material or tools being handled, or equipment operated.
- E26.2 "**Manitoba Hydro Central Stores**" means Manitoba Hydro's Waverley Service and Reclaim Centre – 1840 Chevrier Boulevard – Winnipeg, Manitoba.
- E26.3 "**Overhead Feed**" means an electrical supply via an overhead conductor connected between streetlight standards. Typically strung between standards on a temporary basis.
- E26.4 "**Overhead Source**" means an electrical supply from Manitoba Hydro's system. (Typically an overhead conductor from a wooden distribution pole or a DIP/RISER located on a wooden distribution pole).
- E26.5 "**Reclaim**" material means existing material that has been removed from Manitoba Hydro's system and to be returned to Manitoba Hydro.
- E26.6 "**Scrap**" material means existing material that has been removed from Manitoba Hydro's system and to be recycled/disposed of by the Contractor.
- E26.7 "**Surplus**" material means new material that has been requisitioned by the Contractor and not incorporated into the Work at the end of the Contract.
- E26.8 "**Work Clearance**" means an "**Electrical And/Or Natural Gas Facilities Locate**" form (see SAMPLE ONLY included as Appendix 'E') issued by each of Manitoba Hydro's Customer Service Centre (CSC) affected to permit work to commence (Permit to work).

### DESCRIPTION

- E26.9 The Work shall consist of the supply of all supervision, labour, materials (except as indicated under MATERIAL SUPPLIED BY MANITOBA HYDRO below) insurance, tools, backfill and equipment (and their maintenance), transportation, fuel, oil, meals and lodging, mobilization and de-mobilization, and warranty of workmanship as required to install and remove temporary Overhead Feeds, remove existing street light poles as required, install new street light poles and associated underground cables/conduits, all in accordance with the requirements specified in the Tender Documents.

### WORK LOCATIONS

- E26.10 The proposed street light installation and removals are shown on construction Drawings and are as follows:
- (a) Bowman Avenue between Henderson Highway and Roch Street.

### COORDINATION OF WORK

- E26.11 The Contractor shall provide a minimum of ten (10) Working Days' notice to Manitoba Hydro prior to the start of construction. The Work shall be conducted and coordinated with Manitoba Hydro in a manner to ensure street lighting is maintained at all times for the duration of the Work. The construction Drawings provide the Proposed Sequence of Construction.

- E26.12 The Contractor shall obtain Work Clearance from Manitoba Hydro's Customer Service Centre(s) (CSC) affected prior to the Work commencing. No additional compensation shall be paid to the Contractor for delays obtaining Work Clearance for any reason.
- E26.13 Manitoba Hydro's CSC will provide the Limits of Approach applicable to the Contractor on the Work Clearance form.

#### ORIENTATION

- E26.14 Prior to the commencement of the proposed Work, the Contractor's crew foremen, electricians, and other key personnel shall attend one (1) day of orientation provided by Manitoba Hydro for various operations such as cable handling, cable splicing/termination, installation of street light poles, concrete bases, luminaires and various other construction standards and procedures. The Contractor will be responsible for all costs associated with personnel salaries, travel, sustenance and overheads, etc., during training.

#### PRE-CONSTRUCTION MEETING

- E26.15 Prior to the commencement of the Work, the Contractor shall attend a pre-construction meeting with Manitoba Hydro. The agenda for this meeting shall include but not be limited to the following:
- (a) reference the Contractor's Safe Work Procedures;
  - (b) prime Contractor;
  - (c) materials;
  - (d) sequence of construction;
  - (e) communication plan;
  - (f) any training requirements and qualifications;
  - (g) Drawing and Project review;
  - (h) a review of the Contractor's proposed work schedule; and
  - (i) any and all other topics of clarification that the Contractor and the Contract Administrator may wish to discuss.
- E26.16 The Contractor's cost to attend this pre-construction meeting shall be incorporated into the unit prices for the Work.

#### QUALIFICATIONS AND CERTIFICATION

- E26.17 The Contractor's Crew Foreman, installers and other key Contractor's Personnel shall possess the necessary certification, licensing, training, experience and familiarity with safety rules, procedures and hazards relating to the Work. Journeyman Power Line Technician (PLT), Journeyman Lineman, Journeyman Cableman or Journeyman Electricians shall be required to perform portions of this Work.
- E26.18 Journeyman Power Line Technician (PLT), Journeyman Cableman and Journeyman Lineman are also required to possess a "Limited Specialized Trade Licence – 'M-P' Licence – Power Line" issued by the Province of Manitoba.
- E26.19 Manitoba "Safe Work" Bulletin M&E010 dated January 5, 2011 regarding Electrician Licenses discusses the requirements for a "Limited Specialized Trade Licence – 'M-P' Licence – Power Line".
- (a) For more information contact:  
Manitoba Hydro  
Mechanical and Engineering Branch  
500-401 York Avenue  
Winnipeg, Manitoba R3C 0P8

Tel. 204-945-3373  
Fax 204-948-2309

- E26.20 Licensed Journeyman Electricians or Journeyman PLT or Journeyman Cableman or Journeyman Lineman ARE REQUIRED for all cable handling operations included but not limited to: disconnecting cables in the handhole, installation and removal of temporary overhead feeds, installation and connection of ground rods, streetlight cable splices, termination of streetlight cables in handholds and at luminaires. The Contractor shall employ sufficient qualified personnel on its crews to conform to the Electrician's Licensing Act. The Contractor shall be prepared to provide proof of licences to Manitoba Hydro upon request.
- E26.21 The Contractor shall assess the hazards associated with the Work and have documented Safe Work Procedures to perform the Work. It is the Contractor's responsibility to train employees on these procedures. The Contractor shall be prepared to provide proof of training to Manitoba Hydro upon request.

#### REFERENCED STANDARD CONSTRUCTION SPECIFICATIONS

- E26.22 In addition to these Specifications, the Work to be performed by the Contractor relative to the installation and/or replacement of street lighting poles, concrete bases and associated cabling shall be in accordance with the following:
- (a) Manitoba Hydro 66kV and Below Standards;
  - (b) CSA C22.3 No. 7 (latest edition);
  - (c) Canadian Electrical Code (CEC) Part 1 (latest edition); and
  - (d) any other applicable codes collectively, the "Standards".
- E26.23 Revisions and updates to the Manitoba Hydro 66kV and Below Standards are issued periodically and the latest issued version of the Standard will apply. For the convenience of the Contractor for Bidding purposes, excerpts of the Manitoba Hydro 66kV and Below Standards have been included as Appendix 'B'.
- E26.24 In some cases, Municipal, Provincial or Federal laws or this Technical Specification may be more stringent than the CSA Standards. Whenever conflict exists, the Contractor shall comply with the most stringent requirements applicable at the place of the Work.

#### TOOLS, EQUIPMENT AND MATERIALS

- E26.25 The Contractor shall be required to provide all tools and equipment required for performing the specified tasks. Equipment shall be in good operating condition, shall be properly maintained using original equipment manufacturer replacement parts and shall be provided with letters of testing/inspection from the manufacturer when requested. Where the equipment is provided as a kit with multiple parts and tools, the kit shall be complete with all parts required to perform the designed task. Contractor fabricated tools or equipment will not be accepted for use.
- E26.26 The Contractor shall obtain the following specific Electrical Equipment including but not limited to:
- (a) compression tool or tools and associated dies to perform compressions to a maximum size of 1/0 Al (MD-6 compression tools shall not be used); and
  - (b) approved compression tools are:

Manufacture	Type	Model No.	Range
Burndy	In-line, battery	PATMD68-14V	350 Kcmil AL
Cembre	In-line, battery	B54Y (06V081E)	4/0 AWG AL
Burndy	Pistol, battery	BUR PAT60018V	350 Kcmil AL

- E26.27 Dies shall be of the type shown in Standard CD210-21 and CD 210-24 only, must have identical markings, and compression tool die must match die number stamped on connector:
- (a) Modiewark Model #4444 or Fluke 1AC-II Volt Alert potential Indicator;
  - (b) voltage meter – Fluke model #T3C; and
  - (c) insulated wire cutters – used for cutting cable ends square.

E26.28 Alternative equipment manufacturers may be considered upon request by the Contractor and shall be approved for use by Manitoba Hydro prior to use.

E26.29 Manitoba Hydro may reject any tools or equipment that do not appear to be in good condition or fail to successfully provide the required function.

#### MATERIAL SUPPLIED BY MANITOBA HYDRO

E26.30 Manitoba Hydro shall supply all street light poles, concrete bases, breakaway bases, luminaires, street light arms, ground rods, compression sleeves, grommets, nuts, electrical cables, conduits, relays, cable guards, Gel-caps and all other materials noted in the Standards. The Contractor shall sign receipts indicating the location on which the materials are to be used. The material shall be picked up by the Contractor from the following locations:

- (a) Manitoba Hydro Central Stores (contact personnel will be provided to the successful Contractor).

E26.31 Materials requested will be supplied to the Contractor by Manitoba Hydro upon presentation of Manitoba Hydro's Stores Material Order Form. The Contractor shall assume all responsibilities for the loading, unloading, transportation, proper handling, secure storage and working of the materials and shall make replacements at its own expense in case any material is damaged, stolen or lost due to improper handling, storage or poor workmanship.

E26.32 The Contractor shall, at the time of materials release, check and confirm the quantity of materials. Shortages, discrepancies, or damages to materials shall be immediately reported in writing to Manitoba Hydro.

E26.33 After commencing performance of the Work, the Contractor shall continually monitor all material required for the timely completion of the Work and shall report additional material requirements to Manitoba Hydro a minimum of seventy-two (72) hours prior to materials being required to perform the Work. No additional compensation shall be paid as a result of delays due to material shortages where additional material requirements were not reported a minimum of seventy-two (72) hours prior to being required for the work on an active project.

#### MATERIAL SUPPLIED BY CONTRACTOR

E26.34 The Contractor shall be responsible to furnish gravel, sand, 19.05 mm (¾ inch) down limestone, 6.35 mm (¼ inch) down limestone, protective hose (i.e. typically 50.8 mm (two (2) inches) fire hose), duct seal and pit-run material for backfilling around street light poles and around cables as per the Standards. The cost of furnishing the above listed materials shall be incorporated into the unit prices for the Work.

#### SURPLUS, RECLAIM AND SCRAP MATERIAL

E26.35 Upon completion of the Work, the Contractor shall, at its own expense, deliver to Manitoba Hydro Central Stores, all Surplus materials furnished by Manitoba Hydro and not used in the Work, regardless of the location of said material at that time.

E26.36 In addition, the Contractor shall, at its own expense, deliver to Manitoba Hydro Central Stores all Reclaim materials from the Work specifically HPS luminaires. Manitoba Hydro shall be responsible for the proper disposal of Reclaim HPS luminaires. The HPS bulb shall remain installed and unbroken in the Reclaim luminaire. The Contractor shall handle the Reclaim luminaires with care and shall avoid breaking the bulb or refractor.

- E26.37 Manitoba Hydro's preference is to recycle as much Scrap Material as practicable. The Contractor is responsible to remove the Scrap Material, transport to the recycler or Manitoba Hydro approved disposal site, pay for any disposal fees and may retain any recycling value.

#### DE-ENERGIZATION AND LOCKOUT

- E26.38 **Manitoba Hydro** – Where a standard is supplied from an Overhead Source, Manitoba Hydro's staff shall be responsible to disconnect and isolate the street light standard or standards between the standard and Overhead Source. Some street light standards may be temporarily fed from an Overhead Source. This Overhead Source shall be disconnected and removed by Manitoba Hydro staff prior to commencing with the Work. The streetlight circuits will not be Locked Out by Manitoba Hydro.
- E26.39 **The Contractor** – The Contractor shall assess the hazards associated with the Work and employ its own Safe Work Procedure for the Work to be performed. The Contractor's Safe Work Procedure shall include provisions that the street light circuits will not be Locked Out by Manitoba Hydro. The Contractor's Safe Work Procedure shall achieve Lock Out or techniques equivalent to Lock Out.
- E26.40 The Contractor shall complete a job planning form (an example is included as Appendix 'F') on a daily basis before any Work commences and provide Manitoba Hydro with copies of the job plans if requested.

#### TEMPORARY OVERHEAD FEEDS

- E26.41 Manitoba Hydro in consultation with the Contractor will determine if temporary lighting will be provided by the existing street lights or from the new street lights.
- E26.42 When using the existing poles for temporary lighting, Manitoba Hydro shall remove an Overhead Source in accordance with DE-ENERGIZATION AND LOCKOUT section above, prior to the Contractor installing a #4 duplex overhead conductor between the existing poles. The #4 duplex overhead conductor will normally be attached to the tenon of the davit arm near the luminaire with a pre-form grip. Older poles may require a spool insulator be attached to the pole using a pre-form grip to support the #4 duplex overhead conductor. A short length of 2C/#12 copper conductor is connected to the terminals of the luminaire brought out and connected to the #4 duplex overhead conductor. The final span to the Overhead Source shall be installed by Manitoba Hydro.
- E26.43 When using the new poles for temporary lighting, the Contractor shall install the new bases, poles and #4 duplex overhead conductor. The #4 duplex overhead conductor will be attached to the tenon of the davit arm near the luminaire with a pre-form grip. A short length of 2C/#12 copper conductor is connected to the terminals of the luminaire brought out and connected to the #4 duplex overhead conductor. The final span to the Overhead Source shall be installed by Manitoba Hydro.
- E26.44 All material used to provide the temporary overhead feed shall be returned to Manitoba Hydro. Care shall be taken to coil and tag Reclaim conductor for reuse. If used, insulators shall be handled carefully to prevent breakage.

#### SAFE EXCAVATION

- E26.45 The Work shall be performed in accordance with the requirements of Manitoba Hydro's Safe Excavation and Safety Watch Guidelines (latest revision) included as Appendix 'C' and Manitoba Workplace Safety and Health Regulation 217 latest revision.

#### SAFE HANDLING

- E26.46 The Contractor shall apply handling techniques in accordance with Manitoba Workplace Health and Safety Regulation 217 (latest revision).

## ELECTRIC CABLES AND CONDUITS

- E26.47 The Contractor shall use diligent care and proper equipment in handling of all cables, so as not to injure the jacket and avoid gouging, kinking, scratching or abrading the cables. If any material is damaged to any extent, the Contractor shall repair the damages at its own expense, in a manner approved by Manitoba Hydro or will be charged the full cost of the damaged items.
- E26.48 Cable reels shall not be dropped and must be handled and placed/stored in an upright position at all times and shall not be laid flat for any purpose or reason. Cable reels shall be adequately supported on hard surface to prevent the reel from sinking into the ground that can cause undue stress on the cables. Cable reels should be inspected for damages prior to use. If a cable reel is found to be defective, such defect shall be reported immediately to Manitoba Hydro.
- E26.49 The Contractor shall place all material and string the cables in such a manner as to cause the least interference with normal use of the land, street or roadway. All material shall be unloaded in a manner to preserve its condition, prevent loss and/or theft and permit easy access for Manitoba Hydro's inspection.
- E26.50 The Contractor shall provide Manitoba Hydro's inspector sufficient opportunity, in the sole discretion of Manitoba Hydro, to inspect the Work.

## PRECAST CONCRETE BASES

- E26.51 The Contractor shall handle, store, transport and unload the precast concrete bases in a manner to prevent damage to the threaded bolts and conduit casing.
- E26.52 Precast Concrete Bases are extremely heavy. Approximate weight of pre-cast concrete bases are found in the Standards. The Contractor shall only use equipment rated for such weight.

## STREET LIGHT POLES AND ARMS

- E26.53 The Contractor shall handle, store, transport, and provide proper load securement for the poles and arms in a manner to prevent damage.

## LUMINAIRES

- E26.54 The Contractor shall handle, store, transport and unload the luminaires in their original packaging and in a manner to prevent damage.

## SMALL MATERIAL

- E26.55 Photo electric cells, shorting caps, shims, nut covers and associated supplies shall be kept in a suitable warehouse provided by the Contractor at its own expense. Photo electric cells shall be transported and stored in such a manner as to prevent breakage.

## CARE OF MATERIALS

- E26.56 The Contractor shall assume all responsibilities of all the materials and shall replace, at its own expense, any materials damaged, stolen or lost due to improper handling or poor workmanship.

## WIRE AND CABLE REEL STORAGE

- E26.57 Cable reels shall be stored with the flanges upright and resting on a hard surface. At temporary storage sites where the soil may be soft, preservative-treated plywood sheets may be used to keep the flanges from sinking into the ground.
- E26.58 If cable reels must be pancaked or stored on their side in vertical racks, do not lift the reel by the top flange. Spacers (two (2), two (2) by fours (4) placed wide side up) should be placed under the bottom flange and between the reels in order to create a space to insert the forks and lift the reels without damaging the cable.



## REEL HANDLING

- E26.59 When off-loading reels from a truck, reels shall be lowered using a hydraulic gate, hoist or forklift truck. When a reel is rolled from one point to another, care must be taken to see that the reel does not straddle objects such as rocks, pipes, curbs or wooden blocks which could damage the cable or protective covering. A reel should always be rolled on hard surfaces to avoid sinkage and in the opposite direction to the cable wraps to ensure that the reel is rolled in such a direction as to tighten the cable on the reel.
- E26.60 When using a hoist, install a mandrel through the reel arbour hole and attach a sling. Use a spreader bar approximately 152.4 mm (six (6) inches) longer than the overall reel width placed between the sling ends just above the reel flanges. This will prevent bending of the reel flanges and damage to the cable.
- E26.61 If a forklift is used to move a reel, the reel is to be approached from the flange side. Position the forks such that the reel is lifted by both reel flanges. The lift forks shall not contact the cable.
- E26.62 Returnable reels shall be returned promptly to Manitoba Hydro Central Stores and in no case later than three (3) days after the completion of the Work unless otherwise mutually agreed between the Contractor and Manitoba Hydro.

## PRESSURIZED WATER/VACUUM EXCAVATION

- E26.63 Pressurized water/vacuum excavation (PW/VE) shall be used to daylight all buried utilities and structures where excavation by other mechanical means would be expected to provide a physical risk to that utility or structure.
- E26.64 The Work shall be performed in accordance with the requirements of Manitoba Hydro's Safe Excavation and Safety Watch Guidelines (latest revision) included as Appendix 'C'.

## REMOVAL STREET LIGHT POLE FROM EXISTING BASE

- E26.65 This shall include all Work required to remove a street light pole from an existing base as set forth in this Technical Specification. The pole may be on an existing precast concrete base, steel power installed screw base or poured in place concrete base.
- E26.66 The Contractor shall furnish all labour, supplies and materials (except as indicated in the Section "MATERIAL SUPPLIED BY MANITOBA HYDRO") necessary for the removal of the street light pole from the existing base. Care shall be taken to preserve the luminaire. The luminaire shall be reinstalled on the new street light pole or returned to Manitoba Hydro's stores as instructed by the Manitoba Hydro.
- E26.67 The Contractor shall be responsible to transport all Surplus and Reclaim materials to Manitoba Hydro Central Stores and transport and dispose of all Scrap material as set forth in this Specification.

## REMOVAL OF BASE AND DIRECT BURIED STREET LIGHT POLE

- E26.68 This shall include all excavation, whether by auger, pressurized water/vacuum excavation, by hand, or by other methods which may be necessary to remove a base or direct buried street light pole. The base may be poured in place concrete, steel power installed or precast concrete.
- E26.69 The Contractor shall be responsible to transport all Surplus and Reclaim materials to Manitoba Hydro Central Stores and transport and dispose of all Scrap material as set forth in this Specification.
- E26.70 The Contractor is responsible to supply all backfill material as specified in the Standards and carry out all backfill, compacting and leveling of all excavations and voids for removed bases and direct buried street light poles so as to be ready for top soil and seed or sod or as directed by Manitoba Hydro.

## INSTALLATION OF FOUNDATION – CONCRETE BASE

- E26.71 This shall include all excavation, whether by auger, pressurized water/vacuum excavation, by hand, or by other methods which may be necessary to replace or install a concrete base as set forth in this Specification.
- E26.72 The Contractor shall furnish all labour, supplies and material (except as indicated in the Section "MATERIAL SUPPLIED BY MANITOBA HYDRO") necessary to install a new or replace a concrete base. Excavation for the precast concrete base shall be to a diameter and depth specified in Standard CD 300-6. All excess material is to be removed by the Contractor.
- E26.73 The concrete base shall be set on a bed of 19.05 mm ( $\frac{3}{4}$  inch) down limestone. The concrete base backfill material shall be compacted in lifts no more than one hundred fifty (150) mm. Backfill material shall be 19.05 mm ( $\frac{3}{4}$  inch) down limestone. Compacting of backfill material shall be done using a hydraulic tamper. Alternative tamping methods shall be approved by Manitoba Hydro. Underground cables entering the concrete base shall be protected by a length of protective hose supplied by the Contractor and a layer of sand surrounding the cables to protect it from the limestone. The concrete base shall be installed level in all four (4) directions. Final grade must be established prior to installing the concrete bases.
- E26.74 The completed backfill shall be at least equal in compaction to undisturbed soil, as required by the Municipal authorities or elsewhere in this Specification. The Contractor shall level all excavations.
- E26.75 Should settlement occur in the excavation and cause a depression in the surface, the Contractor shall repair the surface. Placing of additional backfill material due to settlement shall be at the Contractor's expense.
- E26.76 The concrete base shall be oriented in the proper direction to allow the easy entrance of the underground cables into the plastic pipe preinstalled in the concrete base. Care shall be taken to prevent damage to the insulation or jacket of the conductors. The cable shall be left long enough to extend one (1) metres beyond the top of the hand hole.

## BASE MOUNTED STREET LIGHT POLES

- E26.77 This shall include all Work required to install the street light pole on the concrete base as set forth in this Specification.
- E26.78 The Contractor shall furnish all labour, supplies and material (except as indicated in the Section "MATERIAL SUPPLIED BY MANITOBA HYDRO") necessary for the installation of the pole (straight shaft or davit) on the concrete base.
- E26.79 Unless otherwise specified on the construction Drawings, the Contractor shall orient the poles so that the hand hole is on the left side of the pole when viewed from the road. A worker should be able to see oncoming traffic when working in the hand hole.
- E26.80 The Contractor shall level the street light pole in all four (4) directions. Levelling shims may be used.
- E26.81 Tightening of bolts shall be performed in a manner that brings the surfaces up evenly. All nuts shall be tightened and torqued in accordance with Standard CD 300-9. The Contractor shall install the nut covers included with the pole.
- E26.82 Unless otherwise specified, excess underground cable and 2C-12 wire shall be left inside the hand hole with the hand hole cover loosely installed.
- E26.83 Existing street light poles may have street signs attached. The Contractor shall remove the signs from the existing pole and temporarily reattach the signs to the new pole. The Contractor shall notify Manitoba Hydro of the location where the signs have been removed.

## LUMINAIRES AND ASSOCIATED WIRING

- E26.84 The Contractor shall furnish labour, supplies and material (except as indicated in the Section "MATERIAL SUPPLIED BY MANITOBA HYDRO") necessary to install the luminaire and associated wiring. Unless otherwise specified, the luminaire shall be installed with a tilt of zero (0) degrees. The Contractor shall install a length of two (2) conductor No. 12 gauge (2C-12) wire from the terminals of the luminaire, through the arm (if applicable), down the pole to the hand hole. One (1) metres of 2C-12 wire shall be left at the hand hole. Impact equipment (air or electric) shall not be used to tighten luminaire mounting bolts. The Contractor shall be liable for damage due to over tightening.
- E26.85 The Contractor shall verify the luminaire voltage matches the source voltage as shown on the construction Drawings. If luminaire voltage does not match the source voltage, the Contractor shall re-wire the luminaire in accordance with the wiring diagram provided. NOTE: Not applicable for LED luminaires.
- E26.86 As specified on the construction Drawings, the luminaire will require either a photo electric cell (PEC) or shorting cap installed. When installing the PEC the eye shall be oriented north. The Contractor shall also install the appropriate wattage bulb in the luminaire. NOTE: Bulb installation not applicable for LED luminaires.

## BREAK AWAY BASES

- E26.87 Break away bases shall be installed in accordance with Standard CD 300-10. The height of the concrete base above grade shall not exceed fifty (50) mm. The surface of the concrete base shall be flat and level. A reaction plate shall be installed between the concrete base and the break-away base.
- E26.88 The Contractor shall torque the couplers in accordance with Standard CD 300-10. Impact tools shall not be used to tighten or torque couplers or nuts associated with a break away base.

## SPLICING/CONNECTING CABLES

- E26.89 The electric cable shall be spliced/terminated as per Standards CD 215-12, CD 215-13, CD 310-1, CD 310-4, CD 310-9 and CD 310-10 with the exception that the Contractor will use a GELCAP-SL-2/0 splice kit (See Appendix 'D'). Termination in the hand hole may include the installation of an inline fuse holder.
- E26.90 The Contractor shall furnish all labour, supplies and material (except as indicated in the Section "MATERIAL SUPPLIED BY MANITOBA HYDRO") necessary to splice/terminate the street light conductor(s).

## EXCAVATION

- E26.91 The Contractor shall furnish all labour, supplies and material (except as indicated in the Section "MATERIAL SUPPLIED BY MANITOBA HYDRO") necessary for the completion and maintenance of grade and line of the street light cables and conduit including water control if found to be necessary. The trench shall be graded to conform to the street light cables and conduit so that the street light cables and conduit rest firmly on a smooth surface throughout its length. All stones or other objects which, in the opinion of Manitoba Hydro might damage the street light cable jacket and conduit shall be removed. Where the presence of rock or other condition prevent a satisfactory bed for the cables, one hundred fifty (150) mm of well-tamped, clean soil or 6.35 mm (¼ inch) down crushed limestone shall be placed in the bottom of the trench. In this case, the spoil bank from trenching operations shall not be allowed to fall into the trench or mix with the soil to be used in backfilling the trench. Loose debris or foreign matter and the spoil bank shall be placed so as not to hinder drainage, damage property, or obstruct traffic.
- E26.92 Trenches shall be dug to such a depth that will provide a minimum cover of six hundred (600) mm from final grade in sodded areas and one thousand (1000) mm in roadways in accordance with Standard CD 305-1.

## LAYING CABLES

- E26.93 Cables are to be lowered in the trench in an orderly fashion so as to maintain a consistent path and straight alignment. All cables shall be lowered in a continuous run (NO SPLICING) and in accordance with the construction Drawings; and shall maintain the necessary separation, where required. All cables shall be of continuous runs and capped and sealed if they are not being installed in the pole at that time. Cables shall not be dragged over paved surfaces.
- E26.94 Once a cable is cut its ends must be sealed immediately with an approved and appropriately sized, heat shrink or cold shrink sealing cap to prevent moisture ingress unless the cable is being installed in the pole at that time.
- E26.95 During the removal of the cable, the reels shall be placed on jacks, stands or trailers with a bar through the arbour holes which will allow the reel to be turned easily, and the cable to be paid out. Cables can be paid out from the bottom or the top of the reel. Cable in coils shall be handled in a similar manner. This can be achieved by supporting the coil in a vertical plane and rotating it by hand as the cable is carefully uncoiled. The cable shall never be pulled over the flange of a reel, or pulled off the side of a coil, since this will introduce a twist in the cable.
- E26.96 During installation, under no circumstance is the cable to be subjected to a bending radius tighter than that detailed in the Standards.
- E26.97 Where specified in the Standards or on the construction Drawings, the Contractor shall install the street light cable in a conduit.

## INSTALLING CONDUIT AND CABLE BY BORING (HORIZONTAL DIRECTIONAL DRILLING)

- E26.98 The Contractor shall dig the approaches and openings necessary to install boring equipment, and the boring equipment used shall be of such a nature as to minimize the opening size required. The boring equipment shall produce a straight hole without unnecessary dips or bends. The bore hole shall be only slightly larger than the outside diameter of the conduits or cables to minimize possible settlement. Cables and conduits shall be pulled in with pulling eyes or using a kellum grip in a manner so as to guard against damage.
- E26.99 During construction as the drill bit crosses each existing facility a lookout shall be assigned by the Contractor to visually confirm the drill bit is maintaining a minimum three hundred (300) mm clearance from the existing facility all in accordance with Manitoba Hydro Safe Excavation and Safety Watch Guidelines (latest revision) included as Appendix 'C'. Maximum pulling tensions on any streetlight cable shall be limited to 2.9 kN/0.65 kips.
- E26.100 Drilling fluids and associated waste materials shall be disposed of in a manner that minimizes environmental effects.
- E26.101 The Contractor shall properly compact the backfill material and will be responsible for placing additional material should settlement occur for the duration of the warranty period.

## BURIED UTILITY CROSSINGS

- E26.102 All buried obstructions are not necessarily shown on the reference Drawings and the locations of those indicated are approximate only.
- E26.103 The Contractor shall determine the location of all buried obstructions and shall notify the appropriate authorities and obtain all necessary permits prior to excavation, trenching and directional drilling near or across such obstructions. All buried obstructions where the new buried cable route crosses other utilities including but not limited to gas, water, sewer, telephone and electric lines shall be exposed as per each utilities guidelines by the Contractor, including the use of Pressurized Water/Vacuum Equipment (PW/VE) where necessary. Should any damage occur to such lines during the course of the Work, the Contractor shall be responsible for the damage and the costs of repairs to buried obstructions caused by its operations and shall fully indemnify the City of Winnipeg and Manitoba Hydro from and against all claims arising out of such damage. Manitoba Hydro Safe Excavation and Safety Watch

Guidelines (latest revision) included as Appendix 'C' shall be followed when crossing natural gas pipelines and electrical cables by the directional boring method.

- E26.104 The PW/VE technique, used to expose underground plant in certain conditions, must be performed in accordance with each utility's requirements, including but not limited to Manitoba Hydro, Manitoba Telecom Services, Shaw Cable, etc. PW/VE costs that the Contractor will incur during the Work must be factored into the Contractor's Bid prices. The Contractor shall not be entitled to extra compensation for the use of PW/VE on the Work.
- E26.105 The Contractor shall be responsible to supply all backfill material and carry out all backfill, compacting and leveling of all excavations so as to be ready for topsoil and seed or sod or as directed by Manitoba Hydro.

#### BENDING CABLES/CONDUITS AND INSTALLATION INTO STANDARDS

- E26.106 It is desired to reduce to a minimum the required number of bends and to lay the cables/conduits to conform to the contour of the ground and maintain a normal covering. This shall be accomplished by cutting the trench slightly deeper in approaches to road crossings and drainage ditches. It is intended that the Contractor shall eliminate unnecessary bending by operating the trenching machine at various depths rather than by finishing grading the trench by hand whenever practical.
- E26.107 Sharp bends of the cables/conduits shall be avoided at all times. All bends shall meet the requirements set out in this Specification. If excessive bending was exerted on any cable, the cable shall be replaced at the Contractor's cost. During installation, under no circumstance is the cable to be subjected to a bending radius tighter than that detailed in the Standards. At street light poles the Contractor shall install the ends of the cables into the plastic pipe preinstalled in the concrete base. Care shall be taken to prevent damage to the insulation or jacket of the conductors. Underground cables entering the concrete base shall be protected by a length of protective hose supplied by the Contractor and by a layer of sand surrounding the cables to protect it from the limestone. The cable shall be left long enough to extend one (1) metres beyond the hand hole. The street light cable in the trench shall be installed in conduit for mechanical protection and the ends sealed with duct seal supplied by the Contractor. Care shall be taken to prevent damaging the cable where it exits the conduit. The conduit shall only be installed into the concrete base if conduit sizes make it practicable.
- E26.108 Unless otherwise directed, excess underground cable and 2C-12 wire shall be left inside the hand hole with the hand hole cover loosely installed.

#### BACKFILL

- E26.109 All backfilling material within three hundred (300) mm of the cables/conduits shall be clean, free of sod, vegetation, organic material, stones or other debris, and of a consistency as to not create significant voids or air spaces around the cables/conduits. Other backfilling material shall be free of stones greater than one hundred fifty (150) mm on their maximum dimension. Where cinders or very acid soil are encountered or where gravel or incompressible fill is required by Municipal authorities, 6.35 mm (¼ inch) down crushed limestone shall be placed all around the cables for a depth of at least three hundred (300) mm. The completed backfill shall be at least equal in compaction to undisturbed soil or as directed by Manitoba Hydro. Backfill material is to be placed and compacted in lifts not exceeding three hundred (300) mm. All excess material is to be removed by the Contractor.
- E26.110 Tamping or flushing methods must be used where necessary to give the required compaction. Where tamping is used, hand tampers shall be used to at least three hundred (300) mm above the cable before machine tamping may be used. The Contractor shall level all excavations so as to be ready for topsoil and seed or sod or as directed by the Manitoba Hydro. Should settlement occur in the excavation and cause a depression in the surface, the Contractor shall repair the surface to the satisfaction of the Manitoba Hydro at the Contractor's cost.
- E26.111 Excavations remaining where poles have been removed shall be backfilled with spoil, pit run gravel or 19.05 mm (¾ inch) down limestone and compacted in lifts of one hundred fifty (150)

mm as directed by Manitoba Hydro. The top three hundred (300) mm of the excavation shall be backfilled with topsoil.

E26.112 Excavations remaining where utility crossings have been exposed shall be backfilled with sand or clean spoil and compacted in lifts of one hundred fifty (150) mm. The top three hundred (300) mm of the excavation shall be backfilled with topsoil.

E26.113 Backfill of all excavations shall be in accordance with City of Winnipeg Standard Construction Specification CW 2030 (latest revision), to the satisfaction of the authority having jurisdiction and Manitoba Hydro.

#### DEFECTIVE WORK AND WARRANTY

E26.114 If any portion of the Work fails to comply with the requirements of this Specification, fails within the Warranty period, or if the final tests prove or indicate the existence of any fault or defect in the Work, or any part thereof, Manitoba Hydro may forthwith re-execute or make good the faulty or defective Work or alter the same to make it comply with requirements of the Specification at the Contractor's expense. Manitoba Hydro shall give the Contractor notice together with particulars of such failure, fault or defect, Manitoba Hydro's cost to re-execute or make good the faulty or defective Work and the Cost shall be deducted from the Contract.

E26.115 At the completion of the Work for each location, Manitoba Hydro shall prepare and issue a Network Commissioning Report, a sample of which is included as Appendix 'G', to the Contractor. The Network Commissioning Report shall be dated indicating the commencement of the Warranty period for the Work performed at the location.

#### AS-BUILT DRAWING

E26.116 The Contractor shall provide an as-built Drawing or mark-up Drawing to Manitoba Hydro which accurately displays the "as-built" location of the buried street light cables, conduits and street light poles.

#### MEASUREMENT AND PAYMENT

E26.117 Removal of twenty-five (25) foot to thirty-five (35) foot street light pole and precast, poured in place concrete, steel power installed base or direct buried including davit arm, luminaire and appurtenances:

(a) This pay item will be measured on a unit basis and paid for at the Contract Unit Price per unit for "Removal of twenty-five (25) foot to thirty-five (35) foot street light pole and precast, poured in place concrete, steel power installed base or direct buried including davit arm, luminaire and appurtenances". The number of units to be paid for at the Contract Unit Price shall be verified and accepted by Manitoba Hydro. The Price shall be payment in full for performing all operations herein described including removal of the pole, base, luminaire, appurtenances, use of pressurized water/vacuum excavation, transportation of Reclaim, Surplus and Scrap material, payment of associated disposal fees and all other items incidental to the Work included in the Specification.

E26.118 Removal of forty-five (45) foot street light pole and precast, poured in place concrete, steel power installed base or direct buried including davit arm, luminaire and appurtenances:

(a) This pay item will be measured on a unit basis and paid for at the Contract Unit Price per unit for "Removal of forty-five (45) foot street light pole and precast, poured in place concrete, steel power installed base or direct buried including davit arm, luminaire and appurtenances". The number of units to be paid for at the Contract Unit Price shall be verified and accepted by Manitoba Hydro. The Price shall be payment in full for performing all operations herein described including removal of the pole, base, luminaire, appurtenances, use of pressurized water/vacuum excavation, transportation of Reclaim, Surplus and Scrap material, payment of associated disposal fees and all other items incidental to the Work included in the Specification.

E26.119 Installation of Conduit and #4 AL C/N or 1/0 AL Triplex Streetlight Cable in Conduit by Open Trench Method:

- (a) This pay item will be measured on a linear metre basis and paid for at the Contract Unit Price per linear metre for "Installation of Conduit and #4 AL C/N or 1/0 AL Triplex streetlight cable in Conduit by open trench method". The number of metres to be paid for at the Contract Unit Price shall be measured and accepted by Manitoba Hydro. The Price shall be payment in full for performing all operations herein described including installation of the conduit, pulling cable into the conduit, backfilling the trench, buried utility crossings, use of pressurized water/vacuum excavation and all other items incidental to the Work included in the Specification.

E26.120 Installation of fifty (50) mm Conduit by Boring Method complete with Cable Insertion (#4 AL C/N or 1/0 AL Triplex):

- (a) This pay item will be measured on a linear metre basis and paid for at the Contract Unit Price per linear metre for "Installation of fifty (50) mm conduit or conduits by boring method complete with cable insertion (#4 AL C/N or 1/0 AL Triplex)." The number of metres to be paid for at the Contract Unit Price shall be measured and accepted by Manitoba Hydro. The Price shall be payment in full for performing all operations herein described including installation of fifty (50) mm conduit or conduits by boring method, inserting the #4 AL C/N or 1/0 AL Triplex streetlight cable into the conduit(s), buried utility crossings, use of pressurized water/vacuum excavation and all other items incidental to the Work included in the Specification.

E26.121 Installation of cable (#4 AL C/N or 1/0 AL Triplex) by boring method:

- (a) This pay item will be measured on a linear metre basis and paid for at the Contract Unit Price per linear metre for "Installation of cable(s) (#4 AL C/N or 1/0 AL Triplex) by boring method." The number of metres to be paid for at the Contract Unit Price shall be measured and accepted by Manitoba Hydro. The Price shall be payment in full for performing all operations herein described including installation of the cable or cables by boring method, buried utility crossings, use of pressurized water/vacuum excavation and all other items incidental to the Work included in the Specification.

E26.122 Installation of twenty-five (25) foot/thirty-five (35) foot Pole, Davit Arm and Precast Concrete Base Including Luminaire and Appurtenances:

- (a) This pay item will be measured on a unit basis and paid for at the Contract Unit Price per unit for "Installation of twenty-five (25) foot/thirty-five (35) foot pole, davit arm and precast concrete base including luminaire and appurtenances." The number of units to be paid for at the Contract Unit Price shall be verified and accepted by Manitoba Hydro. The Price shall be payment in full for performing all operations herein described including installation of the pole, davit arm, base, luminaire, appurtenances, placing the cable(s) into the base, use of pressurized water/vacuum excavation and all other items incidental to the Work included in the Specification.

E26.123 Installation of forty-five (45) foot Pole, Davit Arm and Precast Concrete Base Including Luminaire and Appurtenances:

- (a) This pay item will be measured on a unit basis and paid for at the Contract Unit Price per unit for "Installation of forty-five (45) foot pole, davit arm and precast concrete base including luminaire and appurtenances." The number of units to be paid for at the Contract Unit Price shall be verified and accepted by Manitoba Hydro. The Price shall be payment in full for performing all operations herein described including installation of the pole, davit arm, base, luminaire, appurtenances, placing the cable(s) into the base, use of pressurized water/vacuum excavation and all other items incidental to the Work included in the Specification.

E26.124 Installation of One (1) ten (10) foot Ground Rod at Every Third Street Light, at the End of a Street Light Circuit or Anywhere Else as Shown on the Design Drawings. Trench #4 Ground Wire up to One (1) metres From Rod Location to New Street Light and Connect (Hammerlock) to Top of Ground Rod:

- (a) This pay item will be measured on a unit basis and paid for at the Contract Unit Price per unit for "Installation of one (1) ten (10) foot ground rod at every third street light, at the end of a street light circuit or anywhere else as shown on the design Drawings. Trench #4 ground wire up to one (1) metres from rod location to new street light and connect (hammerlock) to top of the ground rod." The number of units to be paid for at the Contract Unit Price shall be verified and accepted by Manitoba Hydro. The Price shall be payment in full for performing all operations herein described including install one (1) ten (10) foot ground rod, trench the #4 ground wire to the new streetlight pole, connect (hammerlock) ground wire to rod and all other items incidental to the Work included in the Specification.
- E26.125 Installation of Lower Three (3) metres of Cable Guard, Ground Lug, Cable Up Pole, and First 3 M Section of Ground Rod Per Standard CD 315-5:
- (a) This pay item will be measured on a unit basis and paid for at the Contract Unit Price per unit for "Install/lower three (3) metres of Cable Guard, ground lug, cable up pole, and first three (3) metres section of ground rod per Standard CD 315-5". The number of units to be paid for at the Contract Unit Price shall be verified and accepted by Manitoba Hydro. The Price shall be payment in full for performing all operations herein described including installing the lower section of cable guard, ground lug, ground rod, coiling cable(s) up the pole and all other items incidental to the Work included in the Specification.
- E26.126 Installation and Connection of Externally-Mounted Relay and PEC Per Standards CD 315-12 and CD 315-13:
- (a) This pay item will be measured on a unit basis and paid for at the Contract Unit Price per unit for "Installation and connection of externally-mounted relay and PEC per Standards CD 315-12 and CD 315-13". The number of units to be paid for at the Contract Unit Price shall be verified and accepted by Manitoba Hydro. The Price shall be payment in full for performing all operations herein described including mounting the relay, PEC, wiring as per the schematic and all other items incidental to the Work included in the Specification.
- E26.127 Termination of 2/C #12 Copper Conductor to Street Light Cables Per Standard CD310-4, CD310-9 or CD310-10:
- (a) This pay item will be measured on a unit basis and paid for at the Contract Unit Price per unit for "Terminate 2/C #12 copper conductor to street light cables per Standard CD310-4, CD310-9 or CD310-10". The number of units to be paid for at the Contract Unit Price shall be verified and accepted by Manitoba Hydro. The Price shall be payment in full for performing all operations herein described including connection of the 2/C # 12 copper conductor to the #4 C/N or 1/0 Al Triplex cable(s) using a GELCAP-SL-2/0 splice kit and all other items incidental to the Work included in the Specification.
- E26.128 Splicing #4 AL C/N or two (2) Single Conductor Street Light Cables:
- (a) This pay item will be measured on a unit basis and paid for at the Contract Unit Price per unit for "Splicing #4 Al C/N or two (2) single conductor street light cables". The number of units to be paid for at the Contract Unit Price shall be verified and accepted by Manitoba Hydro. The Price shall be payment in full for performing all operations herein described including splicing the #4 AL C/N or two (2) single conductor cables in accordance with Standard CD 215-12 and CD 215-13 and all other items incidental to the Work included in the Specification.
- E26.129 Splicing 1/0 AL Triplex Cable or three (3) Single Conductor Street Light Cables:
- (a) This pay item will be measured on a unit basis and paid for at the Contract Unit Price per unit for "Splicing 1/0 AL triplex cable or three (3) single conductor street light cables". The number of units to be paid for at the Contract Unit Price shall be verified and accepted by Manitoba Hydro. The Price shall be payment in full for performing all operations herein described including splicing the 1/0 Al triplex cable or set of three (3) single conductor cables in accordance with Standard CD 215-12 and CD 215-13 and all other items incidental to the Work included in the Specification.



E26.130 Installation of Break-Away Base and Reaction Plate on Base-Mounted Poles up to thirty-five (35) foot:

- (a) This pay item will be measured on a unit basis and paid for at the Contract Unit Price per unit for "Installation of break-away base and reaction plate on base mounted poles up to thirty-five (35) foot". The number of units to be paid for at the Contract Unit Price shall be verified and accepted by Manitoba Hydro. The Price shall be payment in full for performing all operations herein described including installation of the reaction plate, break-away base and all other items incidental to the Work included in the Specification.

E26.131 Installation of Overhead Span of #4 Duplex Between New or Existing Streetlight Poles and Connect Luminaire to Provide Temporary Overhead Feed:

- (a) This pay item will be measured on per span basis and paid for at the Contract Unit Price per span for "Installation of Overhead Span of #4 duplex Between New or Existing Streetlight Poles and Connect Luminaire to Provide Temporary Overhead Feed". The number of units to be paid for at the Contract Unit Price shall be verified and accepted by Manitoba Hydro. The Price shall be payment in full for performing all operations herein described including attachment of the #4 duplex overhead conductor using a perform grip (c/w spool insulator(s) to davit arm if necessary), sagging conductor, connection of luminaire using 2C#12 copper conductor and all other items incidental to the Work included in the Specification.

E26.132 Removal of Overhead Span of #4 Duplex Between New or Existing Streetlight Poles to Remove Temporary Overhead Feed:

- (a) This pay item will be measured on a per span basis and paid for at the Contract Unit Price per span for "Removal of Overhead Span of #4 duplex Between New or Existing Streetlight Poles to Remove Temporary Overhead Feed". The number of units to be paid for at the Contract Unit Price shall be verified and accepted by the Manitoba Hydro. The Price shall be payment in full for performing all operations herein described including removal of the #4 duplex overhead conductor, spool insulator(s) and all other items incidental to the Work included in the Specification.

E26.133 Expose Underground Cable Entrance of Existing Streetlight Pole and Install New Streetlight Cable(s):

- (a) This pay item will be measured on a unit basis and paid for at the Contract Unit Price per unit for "Expose Underground Cable Entrance of Existing Streetlight Pole and Install New Streetlight Cable(s)". The number of units to be paid for at the Contract Unit Price shall be verified and accepted by Manitoba Hydro. The Price shall be payment in full for performing all operations herein described including excavation and exposure of the underground cable entrance by any means necessary including use of pressurized water/vacuum excavation, installation of the new streetlight cables(s), backfill, compaction and all other items incidental to the Work included in the Specification.

# **APPENDIX 'A'**

# **GEOTECHNICAL REPORT**



# **Geotechnical Investigation**

**Winnipeg Street Investigation (Project 21-R-05)**

**Various Streets, Winnipeg, Manitoba**

**WX19175**

**10 October 2020**



Environment & Infrastructure Solutions  
 440 Dovercourt Drive, Winnipeg Manitoba, Canada R3Y 1N4  
 Phone: (204) 488-2997  
[www.woodplc.com](http://www.woodplc.com)

**Geotechnical Investigation  
 Winnipeg Street Investigation (Project 21-R-05)  
 Wood Project Number - WX19175**

<b>Prepared for:</b>	Dillon Consulting Ltd. 1558 Willson Pl. Winnipeg, Manitoba R3T 0Y4		
<b>Contact:</b>	Taran Peters, P.Eng.		
<b>Report Distribution:</b>			
<b>Dillon Consulting Ltd.:</b>	Taran Peters, P.Eng.		
<b>Third Party:</b>			
<b>Report Classification:</b>	Confidential		
	<b>Name</b>	<b>Job Title</b>	<b>Signature</b>
<b>Prepared by:</b>	Jason Plohman, P.Eng.	Geotechnical Engineer	
<b>Reviewed by:</b>	Brad Wiebe., P.Eng.	Manager of Geotechnical Services, Saskatchewan/Manitoba	
<b>Project Manager:</b>	Jason Plohman, P.Eng.	Geotechnical Engineer	
<b>Other Technical Contributors</b>			
<b>Rev.</b>	<b>Date</b>	<b>Revision Notes</b>	
0	10 October 2020	Issued Final to Client	
<b>Permit Stamp</b>		<b>Engineer Seal</b>	



**Copyright and non-disclosure notice**

The contents and layout of this report are subject to copyright owned by Wood (© Dillon Consulting Ltd.), save to the extent that copyright has been legally assigned by us to another party or is used by Wood under license. To the extent that we own the copyright in this report, it may not be copied or used without our prior written agreement for any purpose other than the purpose indicated in this report. The methodology (if any) contained in this report is provided to you in confidence and must not be disclosed or copied to third parties without the prior written agreement of Wood. Disclosure of that information may constitute an actionable breach of confidence or may otherwise prejudice our commercial interests. Any third party who obtains access to this report by any means will, in any event, be subject to the Third-Party Disclaimer set out below.

**Third Party Disclaimer**

Any disclosure of this report to a third party is subject to this disclaimer. The report was prepared by Wood at the instruction of, and for use by, our client named on the front of the report. It does not in any way constitute advice to any third party who is able to access it by any means. Wood excludes to the fullest extent lawfully permitted all liability whatsoever for any loss or damage howsoever arising from reliance on the contents of this report. We do not however exclude our liability (if any) for personal injury or death resulting from our negligence, for fraud or any other matter in relation to which we cannot legally exclude liability.



## Table of Contents

<b>1.0</b>	<b>Introduction.....</b>	<b>1</b>
<b>2.0</b>	<b>Geotechnical Investigation.....</b>	<b>1</b>
<b>3.0</b>	<b>Subsurface Conditions.....</b>	<b>3</b>
<b>4.0</b>	<b>Closure.....</b>	<b>3</b>



## List of Tables

Table 1-1: Street Location and Investigation Scope.....	1
Table 2-1: Summary of Atterberg and Particle Size Analysis Results.....	2
Table 2-2: Summary of Concrete Core Strengths.....	3

## List of Appendices

### Appendix A

Dowker Avenue

### Appendix B

Riley Crescent

### Appendix C

Grosvenor Avenue 1

### Appendix D

Rockwood Alley

### Appendix E

Harvard Alley

### Appendix F

Grosvenor Avenue 2

### Appendix G

Nathaniel Street 1

### Appendix H

Nathaniel Street 2

### Appendix I

Syracuse Crescent



## 1.0 Introduction

At the authorization of Mr. Taran Peters, P. Eng., of Dillon Consulting Ltd. (Dillon), Wood Environment & Infrastructure Solutions, a division of Wood Canada Limited (Wood), completed a pavement coring and test hole drilling program related to the pavement evaluation and potential asphalt reconstruction and rehabilitation for various streets in Winnipeg, Manitoba. Test hole locations and scope of work for each street are itemized in Table 1-1.

**Table 1-1: Street Location and Investigation Scope**

Street Name	Location	Total Number of Test Holes	Number of Cores Tested	Test Hole Numbers
Dowker Avenue	Crowson Bay to South Drive	5	0	DOW-01 to DOW-05
Riley Crescent	Wicklow Street to Dowker Avenue	4	0	RIL-01 to RIL-04
Grosvenor Avenue 1	Harrow Street to Stafford Street	3	0	GROS1-01 to GROS1-03
Rockwood Alley	Bounded by Rockwood/Dorchester/McMillan/Wilton	2	0	ROCK-01 to ROCK-02
Harvard Alley	Bounded by Harvard/Stafford/Avonherst/Yale	2	0	HAR-01 to HAR-02
Grosvenor Avenue 2	Ash Street to Lindsay Street	9	0	GROS2-01 to GROS2-09
Nathaniel Street 1	Grant Avenue to Lorette Avenue	2	1	NAT1-01 to NAT1-02
Nathaniel Street 2	Fleet Avenue to Dudley Avenue	3	2	NAT2-01 to NAT2-03
Syracuse Crescent	Chancellor Drive to Chancellor Drive	6	0	SYR-01 to SYR-06
<b>Total</b>		<b>36</b>	<b>3</b>	

The geotechnical investigation was completed in general accordance with the Scope of Work and Terms and Conditions outlined in Wood Proposal No. WPG2020.448, dated 21 July 2020.

## 2.0 Geotechnical Investigation

Prior to initiating the field investigation, Wood notified public utility providers (i.e. Manitoba Hydro, Bell MTS, Shaw, etc.) of the intent to drill in order to clear public utilities. All field activities were completed without incident.

Between 14 September and 05 October 2020, Wood supervised the coring and drilling of thirty six (36) holes along the street sections outlined in Table 1-1, located in Winnipeg, Manitoba. The test hole locations are illustrated in Appendices A through I, respectively. All locations were cored using a 137.5 mm diameter core barrel, while test hole drilling was conducted using a truck mounted Mobile B40 drill rig equipped with 125 mm solid stem augers, owned and operated by Maple Leaf Drilling of Springfield, Manitoba. Approximate coring and test hole locations were selected by Dillon.

At each test hole location drilled below the asphalt/concrete pavement, Wood field personnel visually classified the soil stratigraphy within the test holes in accordance with the Modified Unified Soil Classification System (MUSCS) and noted observed seepage and/or sloughing conditions. The in-situ relative consistency of cohesive soil (i.e. clay) was evaluated using a pocket penetrometer. The recorded pocket penetrometer readings are shown on the test hole logs in terms of compressive strength (kPa). Soil



sampling consisted of grab samples obtained at regular depth intervals. All core and grab samples were retained in sealed plastic bags and shipped to Wood's Winnipeg laboratory for review and select testing.

Upon completion of drilling at each test hole location, the holes were left open for 5 minutes and the depths to accumulated slough and groundwater level were measured prior to backfill. Upon obtaining the measurements, all test holes were subsequently backfilled to grade with auger cuttings and bentonite, and patched with cold mix asphalt at the surface.

Following completion of the field drilling program, a laboratory testing program was conducted on select soil samples obtained from the test holes. The laboratory testing program consisted of moisture content determinations, Atterberg limits, particle size distributions (hydrometer method), and California Bearing Ratio (CBR) evaluations on the anticipated subgrade soils as outlined in Dillon's Request for Proposal (RFP). A summary of the laboratory testing results for soil and core strength are shown in Table 2-1 and Table 2-2, respectively.

**Table 2-1: Summary of Atterberg and Particle Size Analysis Results**

Test Hole	Depth (m)	MUSCS Symbol	Atterberg Limits		Particle Size Distribution Results			
			Liquid Limit (%)	Plastic Limit (%)	Gravel (%)	Sand (%)	Silt (%)	Clay (%)
DOW-01	1.2	CH	87	25	0.6	7.0	23.4	69.0
DOW-03	1.2	CH	73	19	0.0	2.5	27.3	70.2
DOW-05	1.2	CH	90	24	0.7	3.4	16.2	79.7
RIL-01	0.8	MLCI	43	15	0.5	13.3	51.0	35.2
RIL-02	0.5	CI	61	24	0.0	6.6	45.1	48.2
RIL-04	0.5	CH	80	24	0.0	3.0	26.8	70.2
GROS1-01	1.8	CH	91	27	0.0	5.6	16.4	78.0
GROS1-02	1.1	CH	95	26	0.0	1.2	13.7	85.1
ROCK-01	1.1	CH	89	25	0.0	1.8	19.0	79.2
ROCK-02	1.1	MLCL	24	16	0.0	11.1	70.6	18.4
HAR-01	1.1	ML	40	15	0.0	7.5	56.7	35.8
HAR-02	1.1	CH	84	23	0.0	0.9	13.1	86.1

**Table 2-2: Summary of Concrete Core Strengths**

Test Hole	Concrete Core Strength (MPa)
NAT1-02	39.2
NAT2-01	36.9
NAT2-03	37.6

It should be noted that strength tests could not be completed on core samples retrieved from the following streets:

- Grosvenor 2 – pavement structure did not contain a concrete slab
- Syracuse Crescent – poor quality of the concrete cores obtained from each of the test hole locations
- Nathaniel 1 – poorly quality of concrete at NAT1-01

At the time this report was prepared all of the above testing has been completed with the exceptions noted above and CBR testing. CBR results will be provided upon their completion.

### 3.0 Subsurface Conditions

Detailed test hole logs summarizing the sampling, field testing, laboratory test results, and subsurface conditions encountered at the test hole locations as well as photographs of the asphalt and concrete cores obtained from each test hole location are presented in Appendices A through I. Actual depths noted on the test hole logs may vary by  $\pm 0.3$  m from those recorded due to the method by which the soil cuttings are returned to the surface. Summaries of the terms and symbols used on the test hole logs and of the Modified Unified Soil Classification System are also presented in Appendix A.

### 4.0 Closure

The findings of this report were based on the results of field and laboratory investigations at test hole locations determined based on the requirements provided by Dillon Consulting Ltd.

The site investigation was conducted for the sole purpose of profiling the pavement and subsurface conditions. Although no environmental issues were identified during the fieldwork, this does not indicate that no such issues exist. If the owner or other parties have any concern regarding the presence of environmental issues, then an appropriate level environmental assessment should be conducted.

Soil conditions, by their nature, can be highly variable across a site. The placement of fill and prior construction activities on a site can contribute to the variability especially near surface soil conditions. A contingency should always be included in any construction budget to allow for the possibility of variation in soil conditions, which may result in modification of any potential design and construction procedures which may arise from this factual investigative report.

This report has been prepared for the exclusive use of Dillon Consulting Ltd., and their agents, for specific application to the project described in this report. The data provided herein should not be used for any other purpose, or by any other parties, without review and written advice from Wood. Any use that a third party makes of this report, or any reliance or decisions made based on this report, are the responsibility of

those parties. Wood accepts no responsibility for damages suffered by a third party as a result of decisions made or actions based on this report.

This report has been prepared in accordance with generally accepted geotechnical engineering practices. No other warranty, either expressed or implied, is made.

Respectfully submitted,

**Wood Environment & Infrastructure Solutions,  
a Division of Wood Canada Limited**

# Appendix A

## Dowker Avenue

- Test Hole Location Plan
- Core Photos
- Test Hole Logs

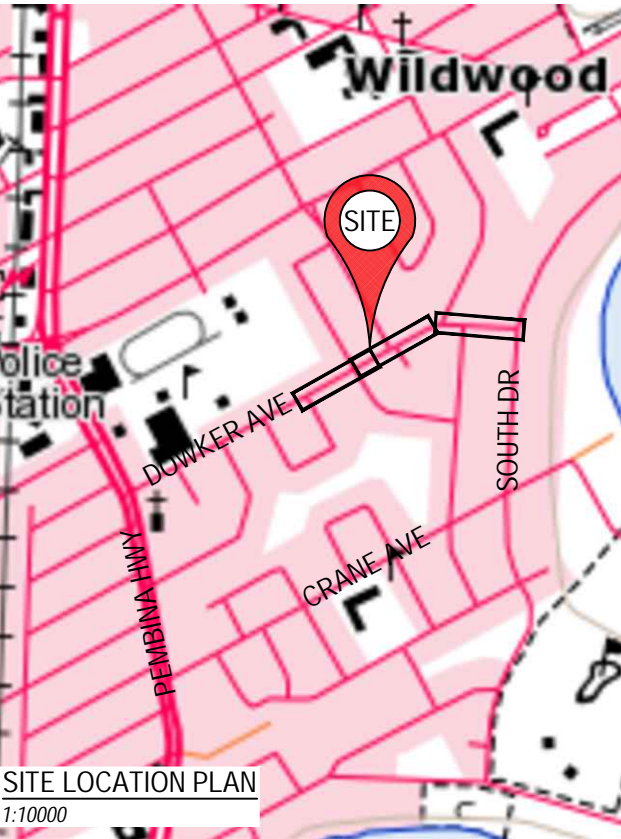
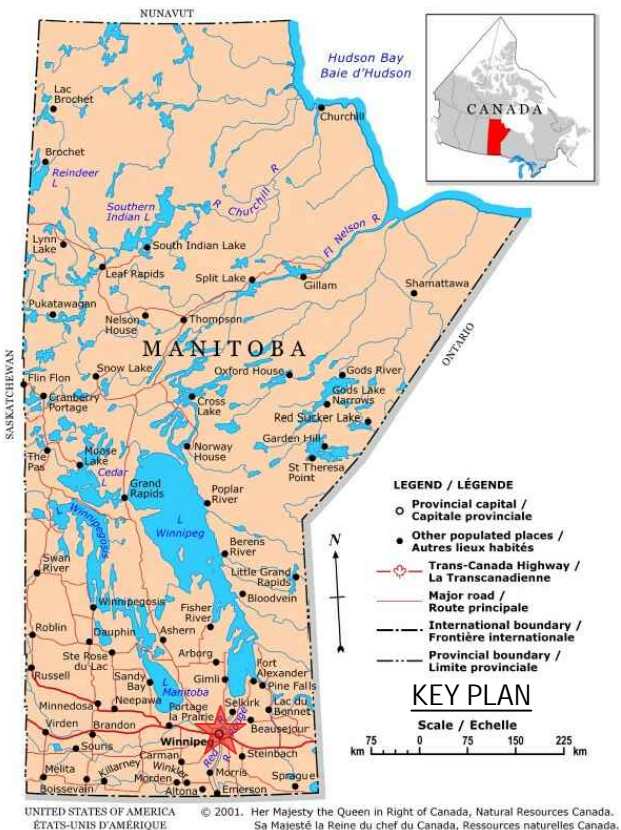

NOTES: SITE FEATURES AND LOCATIONS ARE APPROXIMATE ONLY. IMAGES FROM AUTODESK IMAGERY AND TOPO MAPS.

**LEGEND:**  
TEST HOLE

REVISION	BY	DATE
----	----	----

CLIENT:  
**DILLON CONSULTING LTD.**

**wood.**  
440 DOVERCOURT DRIVE  
WINNIPEG, MANITOBA R3Y 1N4  
PHONE: 204.488.2997 FAX:204.489.8261

DWN BY: MD  
CHK'D BY: JP  
DATUM: ---  
PROJECTION: ---  
SCALE: AS SHOWN

CITY OF WINNIPEG STREET INVESTIGATION  
PROJECT 21-R-05  
WINNIPEG, MANITOBA

**SITE AND TEST HOLE LOCATION PLAN -  
DOWER AVENUE FROM CROWSON BAY TO SOUTH DRIVE**

DATE: OCTOBER 2020  
PROJECT NO: WX19175  
REV. NO.: A  
FIGURE NO: FIGURE 1



DOW-01: Asphalt Layer, Plan View



DOW-01: Asphalt Layer, Profile



DOW-02: Asphalt Layer, Plan View



DOW-02: Asphalt Layer, Profile View

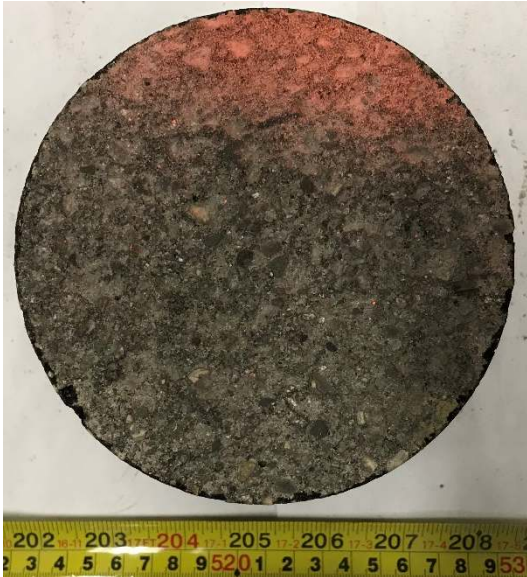

DOW-03: Asphalt Layer, Plan View



DOW-03: Asphalt Layer, Profile



DOW-04: Asphalt Layer, Plan View



DOW-04: Asphalt Layer, Profile View



DOW-05: Asphalt Layer, Plan View

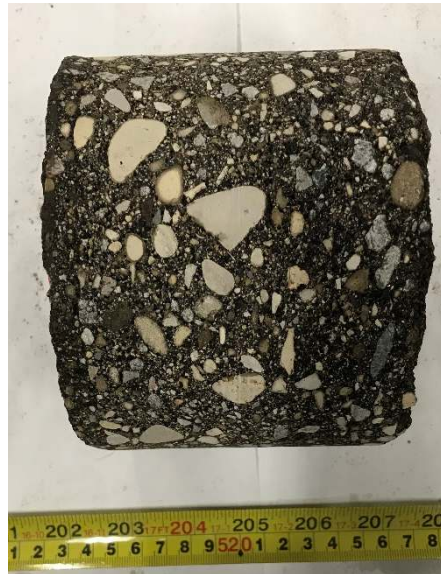

DOW-05: Asphalt Layer, Profile



PROJECT: City of Winnipeg Street Investigation	DRILLER: Maple Leaf Drilling Ltd.	TEST HOLE ID: <b>DOW-01</b>
CLIENT: Dillon Consulting	DRILL RIG: Truck Mounted B40	PROJECT No: WX19175
LOCATION: Dowker Avenue, Winnipeg, MB	DRILL METHOD: 138mm Core & 125mm SSA	ELEVATION: Not Surveyed

SAMPLE TYPE	<input checked="" type="checkbox"/> Shelby Tube	<input type="checkbox"/> No Recovery	<input checked="" type="checkbox"/> SPT (N)	<input type="checkbox"/> Grab Sample	<input type="checkbox"/> Split-Pen	<input type="checkbox"/> Core
BACKFILL TYPE	<input checked="" type="checkbox"/> Bentonite	<input type="checkbox"/> Pea Gravel	<input checked="" type="checkbox"/> Drill Cuttings	<input type="checkbox"/> Grout	<input type="checkbox"/> Slough	<input type="checkbox"/> Sand

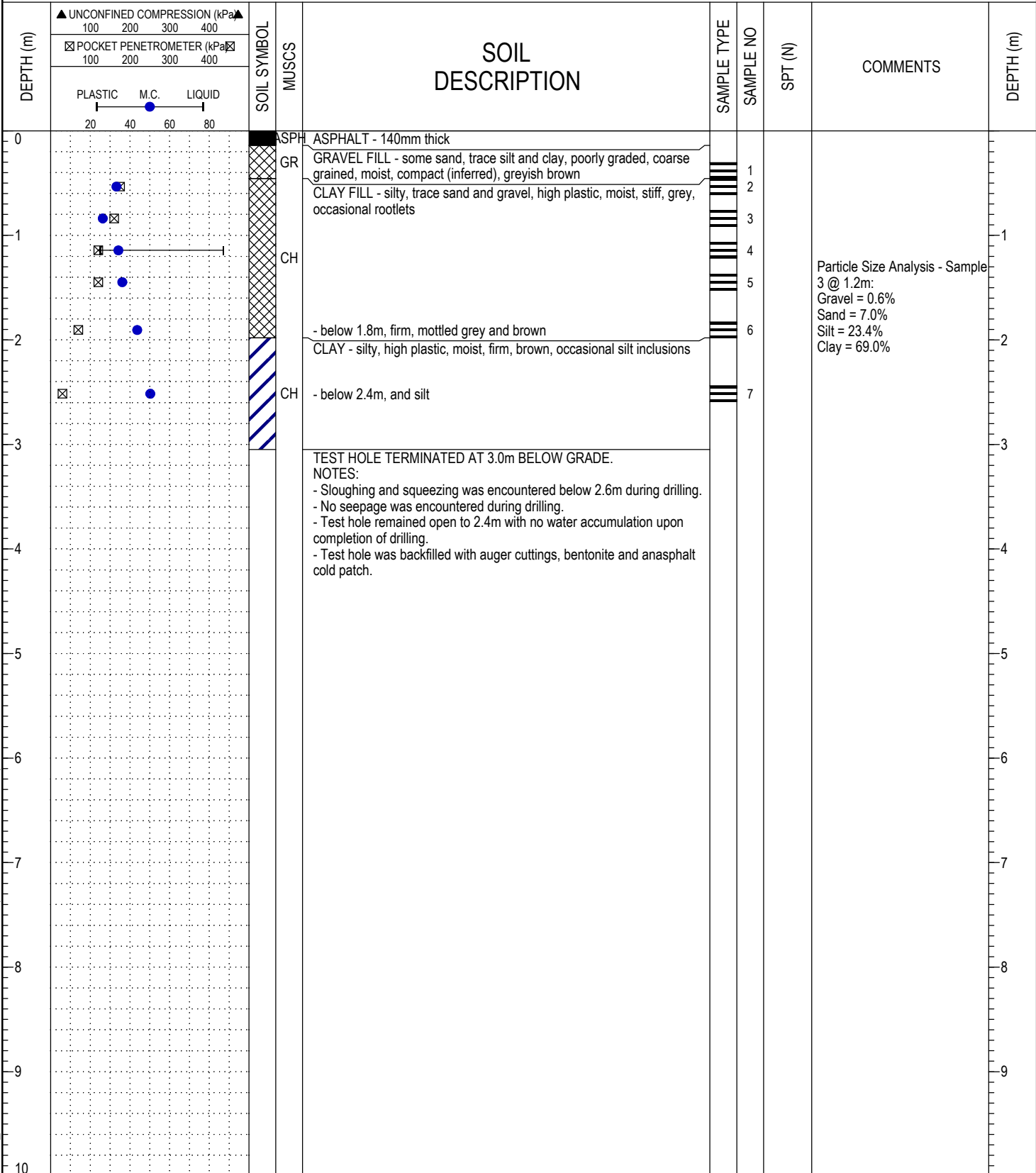

WX19175 - DILLON\_DOWKER AVE R1.GPJ 20/10/09 02:19 PM (WPG - GEOTECH LOG 1)



**Wood Environment & Infrastructure Solutions**  
 a division of Wood Canada Limited

LOGGED BY: AL	COMPLETION DEPTH: 3 m
REVIEWED BY: JP	COMPLETION DATE: September 16, 2020
Figure No.	Sheet 1 of 1

PROJECT: City of Winnipeg Street Investigation	DRILLER: Maple Leaf Drilling Ltd.	TEST HOLE ID: <b>DOW-02</b>
CLIENT: Dillon Consulting	DRILL RIG: Truck Mounted B40	PROJECT No: WX19175
LOCATION: Dowker Avenue, Winnipeg, MB	DRILL METHOD: 138mm Core & 125mm SSA	ELEVATION: Not Surveyed

SAMPLE TYPE	<input checked="" type="checkbox"/> Shelby Tube	<input type="checkbox"/> No Recovery	<input checked="" type="checkbox"/> SPT (N)	<input type="checkbox"/> Grab Sample	<input type="checkbox"/> Split-Pen	<input type="checkbox"/> Core
BACKFILL TYPE	<input checked="" type="checkbox"/> Bentonite	<input type="checkbox"/> Pea Gravel	<input checked="" type="checkbox"/> Drill Cuttings	<input type="checkbox"/> Grout	<input type="checkbox"/> Slough	<input type="checkbox"/> Sand

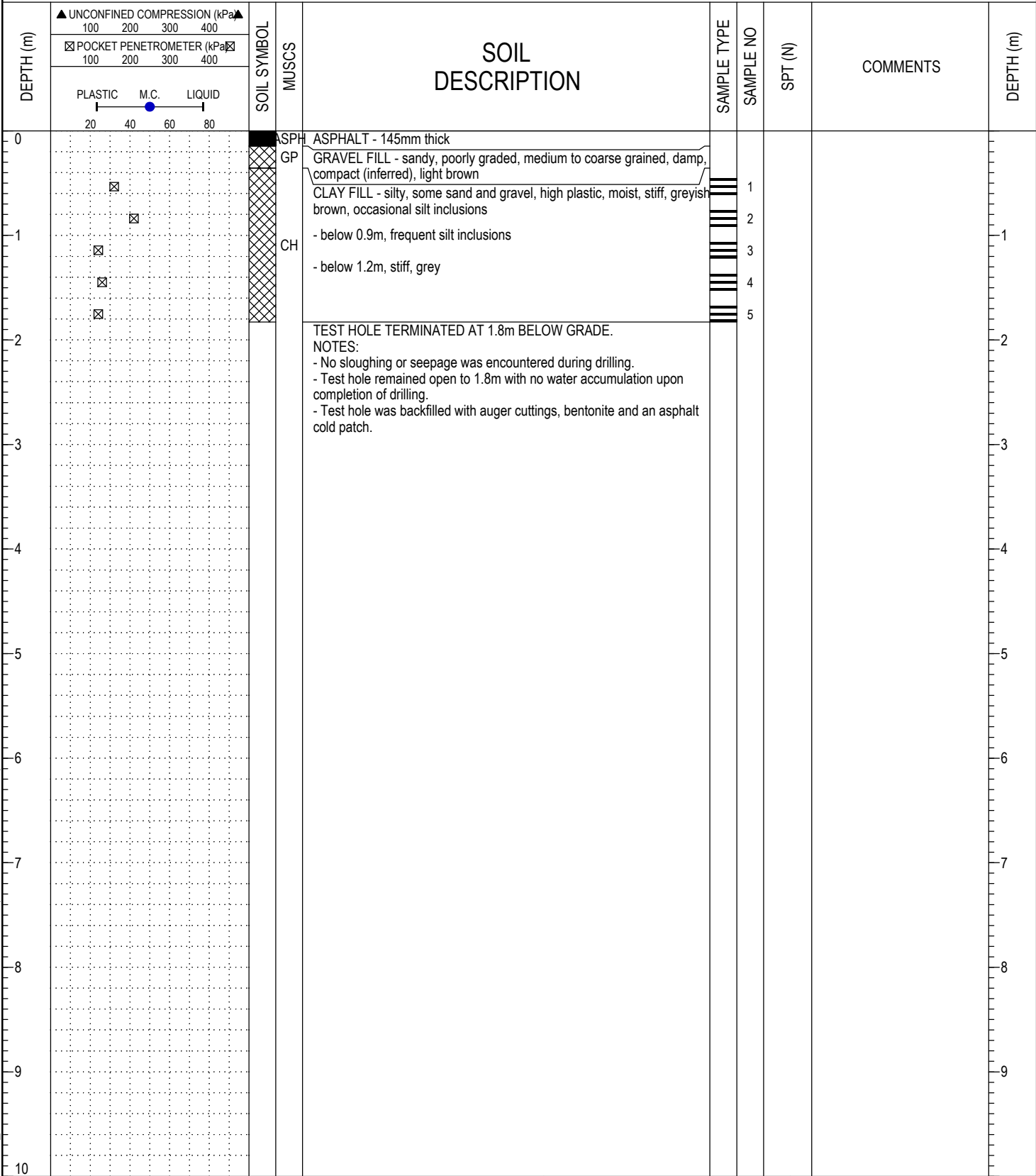

WX19175 - DILLON\_DOWKER AVE R1.GPJ 20/10/09 02:20 PM (WPG - GEOTECH LOG 1)



**Wood Environment & Infrastructure Solutions**  
 a division of Wood Canada Limited

LOGGED BY: AL	COMPLETION DEPTH: 1.8 m
REVIEWED BY: JP	COMPLETION DATE: September 16, 2020
Figure No.	Sheet 1 of 1

PROJECT: City of Winnipeg Street Investigation	DRILLER: Maple Leaf Drilling Ltd.	TEST HOLE ID: <b>DOW-03</b>
CLIENT: Dillon Consulting	DRILL RIG: Truck Mounted B40	PROJECT No: WX19175
LOCATION: Dowker Avenue, Winnipeg, MB	DRILL METHOD: 138mm Core & 125mm SSA	ELEVATION: Not Surveyed

SAMPLE TYPE	<input checked="" type="checkbox"/> Shelby Tube	<input type="checkbox"/> No Recovery	<input checked="" type="checkbox"/> SPT (N)	<input type="checkbox"/> Grab Sample	<input type="checkbox"/> Split-Pen	<input type="checkbox"/> Core
BACKFILL TYPE	<input checked="" type="checkbox"/> Bentonite	<input type="checkbox"/> Pea Gravel	<input checked="" type="checkbox"/> Drill Cuttings	<input type="checkbox"/> Grout	<input type="checkbox"/> Slough	<input type="checkbox"/> Sand

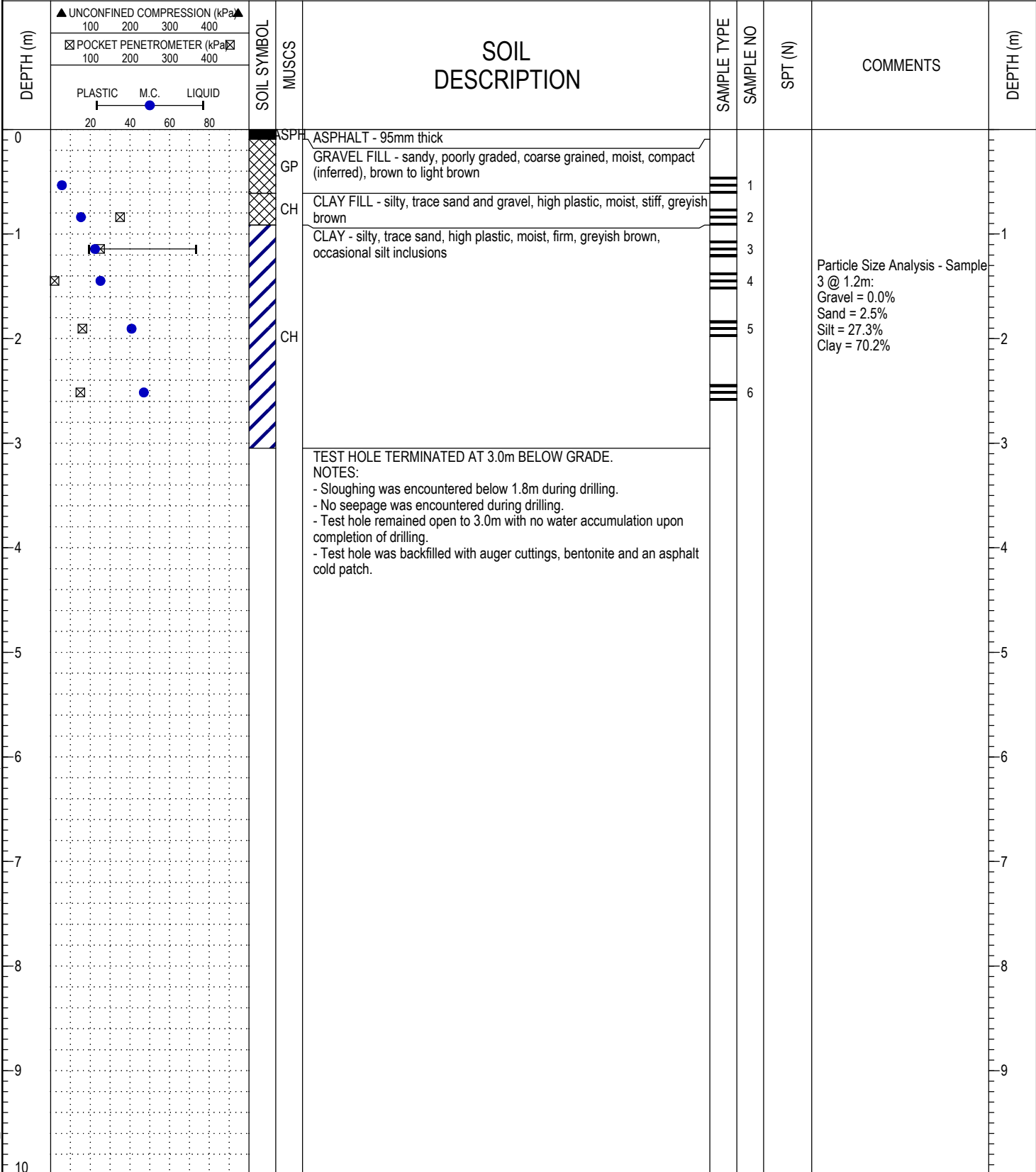

WX19175 - DILLON\_DOWKER AVE R1.GPJ 20/10/09 02:20 PM (WPG - GEOTECH LOG 1)



**Wood Environment & Infrastructure Solutions**  
a division of Wood Canada Limited

LOGGED BY: AL	COMPLETION DEPTH: 3 m
REVIEWED BY: JP	COMPLETION DATE: September 17, 2020
Figure No.	Sheet 1 of 1

PROJECT: City of Winnipeg Street Investigation	DRILLER: Maple Leaf Drilling Ltd.	TEST HOLE ID: <b>DOW-04</b>
CLIENT: Dillon Consulting	DRILL RIG: Truck Mounted B40	PROJECT No: WX19175
LOCATION: Dowker Avenue, Winnipeg, MB	DRILL METHOD: 138mm Core & 125mm SSA	ELEVATION: Not Surveyed

SAMPLE TYPE	<input checked="" type="checkbox"/> Shelby Tube	<input type="checkbox"/> No Recovery	<input checked="" type="checkbox"/> SPT (N)	<input type="checkbox"/> Grab Sample	<input type="checkbox"/> Split-Pen	<input type="checkbox"/> Core
BACKFILL TYPE	<input checked="" type="checkbox"/> Bentonite	<input type="checkbox"/> Pea Gravel	<input checked="" type="checkbox"/> Drill Cuttings	<input type="checkbox"/> Grout	<input type="checkbox"/> Slough	<input type="checkbox"/> Sand

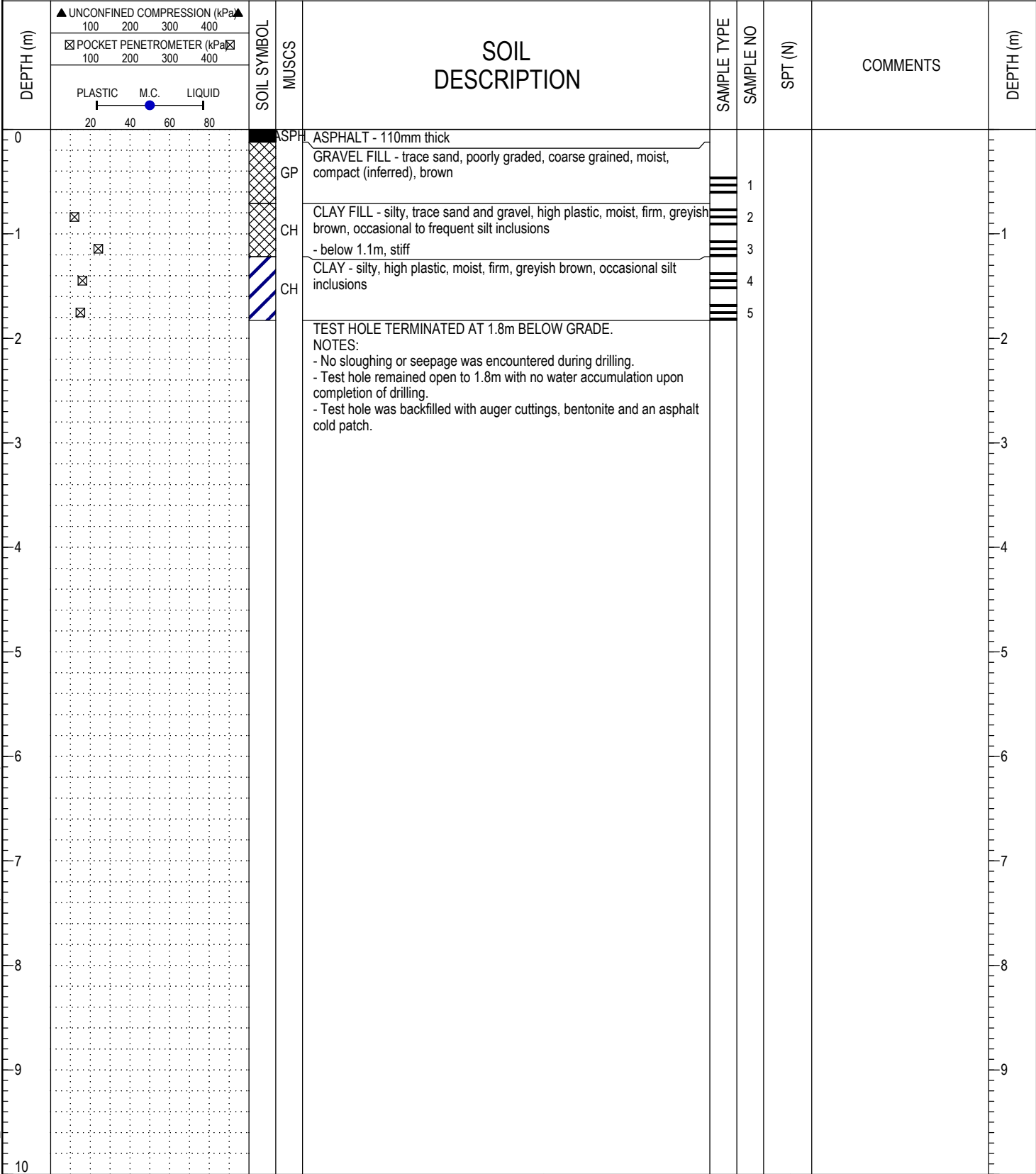

WX19175 - DILLON\_DOWKER AVE R1.GPJ 20/10/09 02:20 PM (WPG - GEOTECH LOG 1)



**Wood Environment & Infrastructure Solutions**  
 a division of Wood Canada Limited

LOGGED BY: AL	COMPLETION DEPTH: 1.8 m
REVIEWED BY: JP	COMPLETION DATE: September 17, 2020
Figure No.	Sheet 1 of 1

PROJECT: City of Winnipeg Street Investigation	DRILLER: Maple Leaf Drilling Ltd.	TEST HOLE ID: <b>DOW-05</b>
CLIENT: Dillon Consulting	DRILL RIG: Truck Mounted B40	PROJECT No: WX19175
LOCATION: Dowker Avenue, Winnipeg, MB	DRILL METHOD: 138mm Core & 125mm SSA	ELEVATION: Not Surveyed

SAMPLE TYPE	<input checked="" type="checkbox"/> Shelby Tube	<input type="checkbox"/> No Recovery	<input checked="" type="checkbox"/> SPT (N)	<input type="checkbox"/> Grab Sample	<input type="checkbox"/> Split-Pen	<input type="checkbox"/> Core
BACKFILL TYPE	<input checked="" type="checkbox"/> Bentonite	<input type="checkbox"/> Pea Gravel	<input checked="" type="checkbox"/> Drill Cuttings	<input type="checkbox"/> Grout	<input type="checkbox"/> Slough	<input type="checkbox"/> Sand

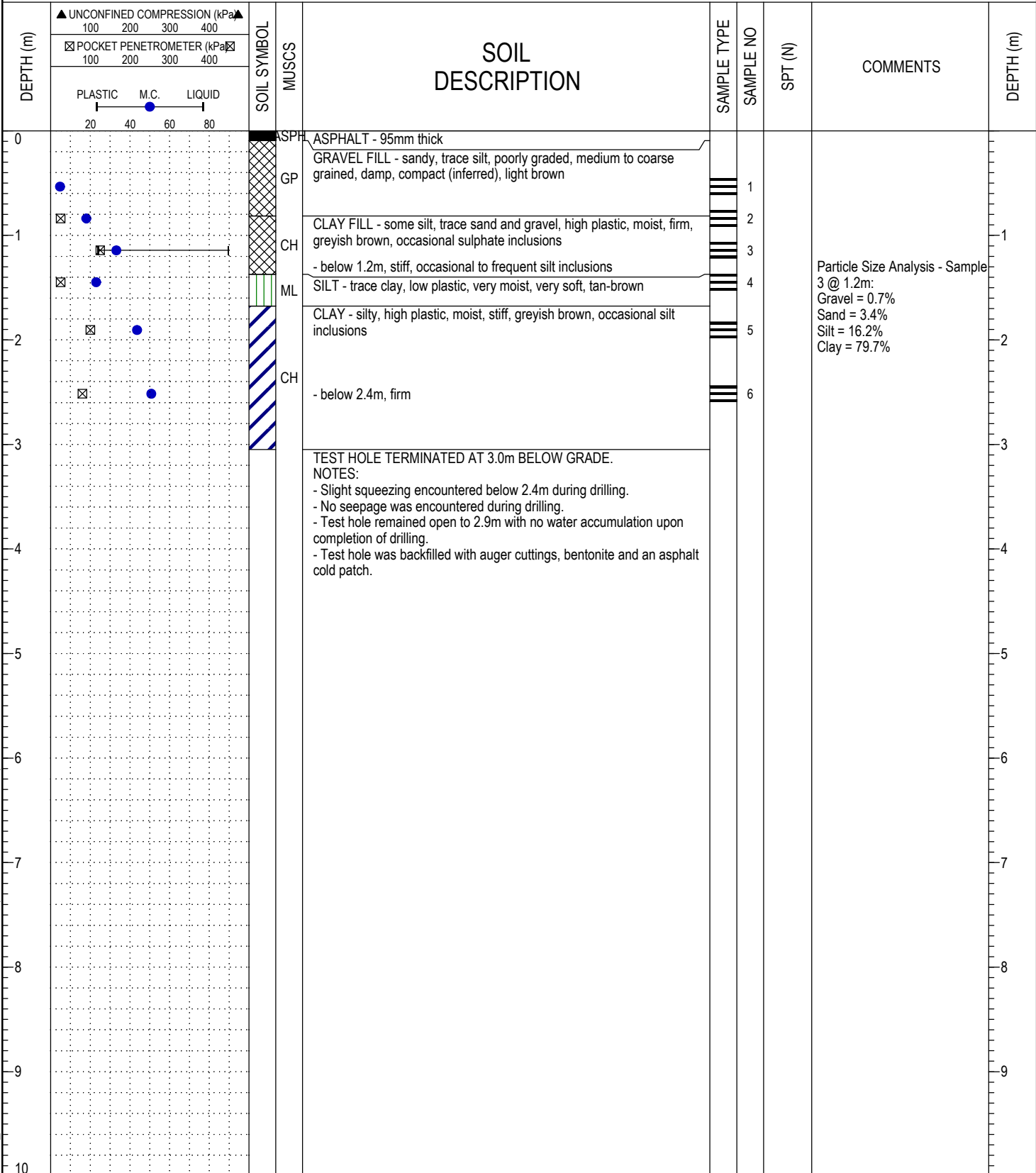

WX19175 - DILLON\_DOWKER AVE R1.GPJ 20/10/09 02:21 PM (WPG - GEOTECH LOG 1)



**Wood Environment & Infrastructure Solutions**  
 a division of Wood Canada Limited

LOGGED BY: AL	COMPLETION DEPTH: 3 m
REVIEWED BY: JP	COMPLETION DATE: September 17, 2020
Figure No.	Sheet 1 of 1

# Appendix B

## Riley Crescent

- Test Hole Location Plan
- Core Photos
- Test Hole Logs

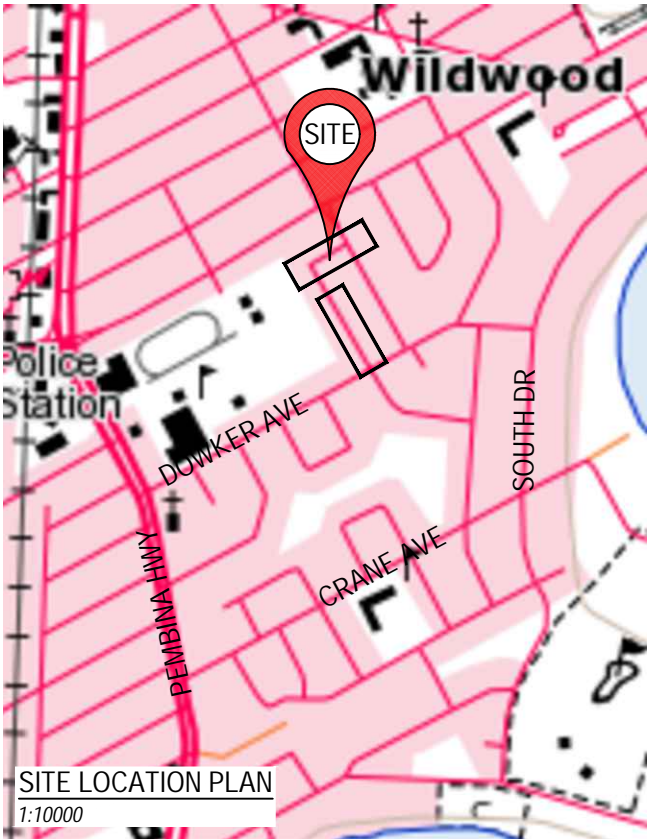
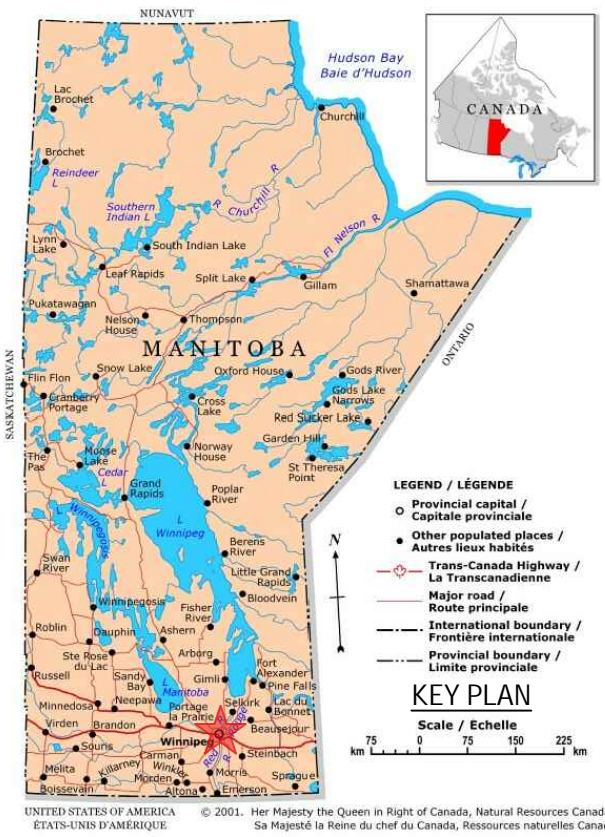

NOTES: SITE FEATURES AND LOCATIONS ARE APPROXIMATE ONLY. IMAGES FROM AUTODESK IMAGERY AND TOPO MAPS.

**LEGEND:**

TEST HOLE

REVISION	BY	DATE
----	----	----

CLIENT:

DILLON CONSULTING LTD.

**wood.**

440 DOVERCOURT DRIVE  
WINNIPEG, MANITOBA R3Y 1N4  
PHONE: 204.488.2997 FAX: 204.489.8261

DWN BY: MD

CHK'D BY: JP

DATUM: ---

PROJECTION: ---

SCALE: AS SHOWN

CITY OF WINNIPEG STREET INVESTIGATION  
PROJECT 21-R-05  
WINNIPEG, MANITOBA

SITE AND TEST HOLE LOCATION PLAN -  
RILEY CRESCENT FROM DOWKER AVENUE TO WICKLOW STREET

DATE: OCTOBER 2020

PROJECT NO: WX19175

REV. NO.: A

FIGURE NO: FIGURE 1



RIL-01: Asphalt Layer, Plan View



RIL-01: Asphalt Layer, Profile View



RIL-01: Concrete Layer, Plan View



RIL-01: Concrete Layer, Profile View



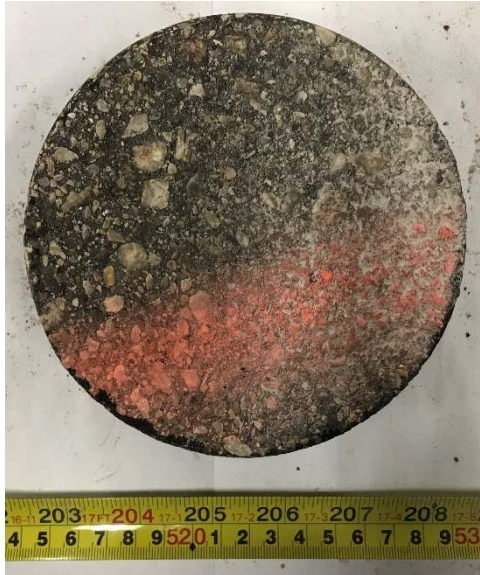

RIL-02: Asphalt Layer, Plan View



RIL-02: Asphalt Layer, Profile View



RIL-02: Concrete Layer, Plan View



RIL-02: Concrete Layer, Profile View



RIL-03: Asphalt Layer, Plan View



RIL-03: Asphalt Layer, Profile View



RIL-03: Concrete Layer (Broken), Plan View



RIL-04: Asphalt Layer, Plan View



RIL-04: Asphalt Layer, Profile View



RIL-04: Concrete Layer (Broken), Plan View

	<p><b>CORE PHOTOGRAPHS</b>  <b>RILEY CRESCENT BETWEEN DOWKER AVENUE AND WICKLOW STREET</b>  <b>WINNIPEG, MANITOBA</b></p>
---	---

<p><b>Wood Environment and Infrastructure Solutions</b></p>	<p><b>DILLON CONSULTING LTD.</b></p>
---	--------------------------------------

<p>Drawn: AL</p>	<p>Scale: N/A</p>	<p>Date: 09 October 2020</p>	<p>Project No.: WX19175</p>	
------------------	-------------------	------------------------------	-----------------------------	--

PROJECT: City of Winnipeg Street Investigation	DRILLER: Maple Leaf Drilling Ltd.	TEST HOLE ID: <b>RIL-01</b>
CLIENT: Dillon Consulting	DRILL RIG: Truck Mounted B40	PROJECT No: WX19175
LOCATION: Riely Street, Winnipeg, MB	DRILL METHOD: 138mm Core & 125mm SSA	ELEVATION: Not Surveyed

SAMPLE TYPE	<input checked="" type="checkbox"/> Shelby Tube	<input type="checkbox"/> No Recovery	<input checked="" type="checkbox"/> SPT (N)	<input type="checkbox"/> Grab Sample	<input type="checkbox"/> Split-Pen	<input type="checkbox"/> Core
BACKFILL TYPE	<input checked="" type="checkbox"/> Bentonite	<input type="checkbox"/> Pea Gravel	<input checked="" type="checkbox"/> Drill Cuttings	<input type="checkbox"/> Grout	<input type="checkbox"/> Slough	<input type="checkbox"/> Sand

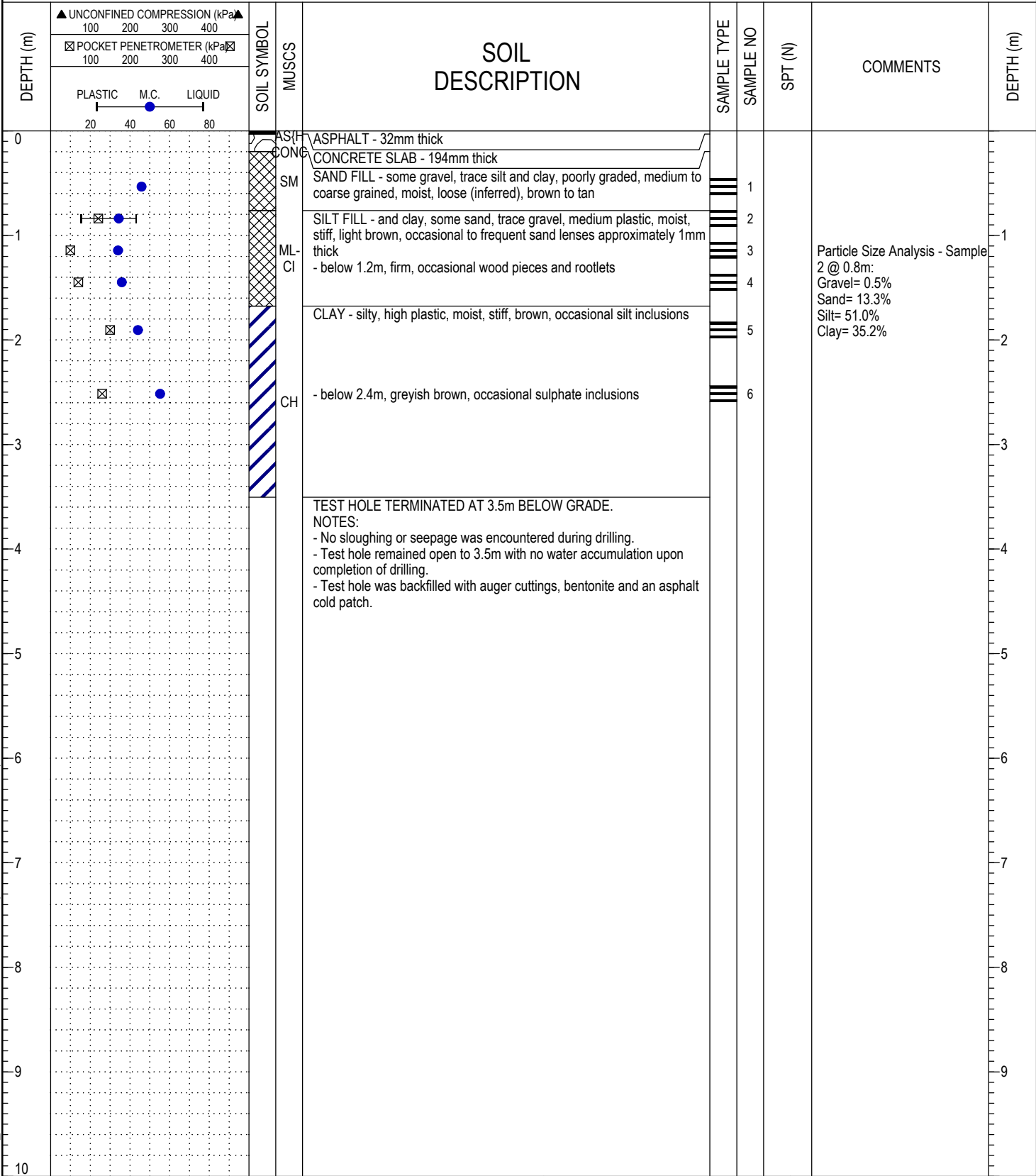

WX19175 - DILLON\_RILEY STREET.R1.GPJ 20/10/09 02:45 PM (WPG - GEOTECH LOG 1)



**Wood Environment & Infrastructure Solutions**  
 a division of Wood Canada Limited

LOGGED BY: AL	COMPLETION DEPTH: 3.5 m
REVIEWED BY: JP	COMPLETION DATE: September 14, 2020
Figure No.	Sheet 1 of 1

PROJECT: City of Winnipeg Street Investigation	DRILLER: Maple Leaf Drilling Ltd.	TEST HOLE ID: <b>RIL-02</b>
CLIENT: Dillon Consulting	DRILL RIG: Truck Mounted B40	PROJECT No: WX19175
LOCATION: Riely Street, Winnipeg, MB	DRILL METHOD: 138mm Core & 125mm SSA	ELEVATION: Not Surveyed

SAMPLE TYPE	<input checked="" type="checkbox"/> Shelby Tube	<input type="checkbox"/> No Recovery	<input checked="" type="checkbox"/> SPT (N)	<input type="checkbox"/> Grab Sample	<input type="checkbox"/> Split-Pen	<input type="checkbox"/> Core
BACKFILL TYPE	<input checked="" type="checkbox"/> Bentonite	<input type="checkbox"/> Pea Gravel	<input checked="" type="checkbox"/> Drill Cuttings	<input type="checkbox"/> Grout	<input type="checkbox"/> Slough	<input type="checkbox"/> Sand

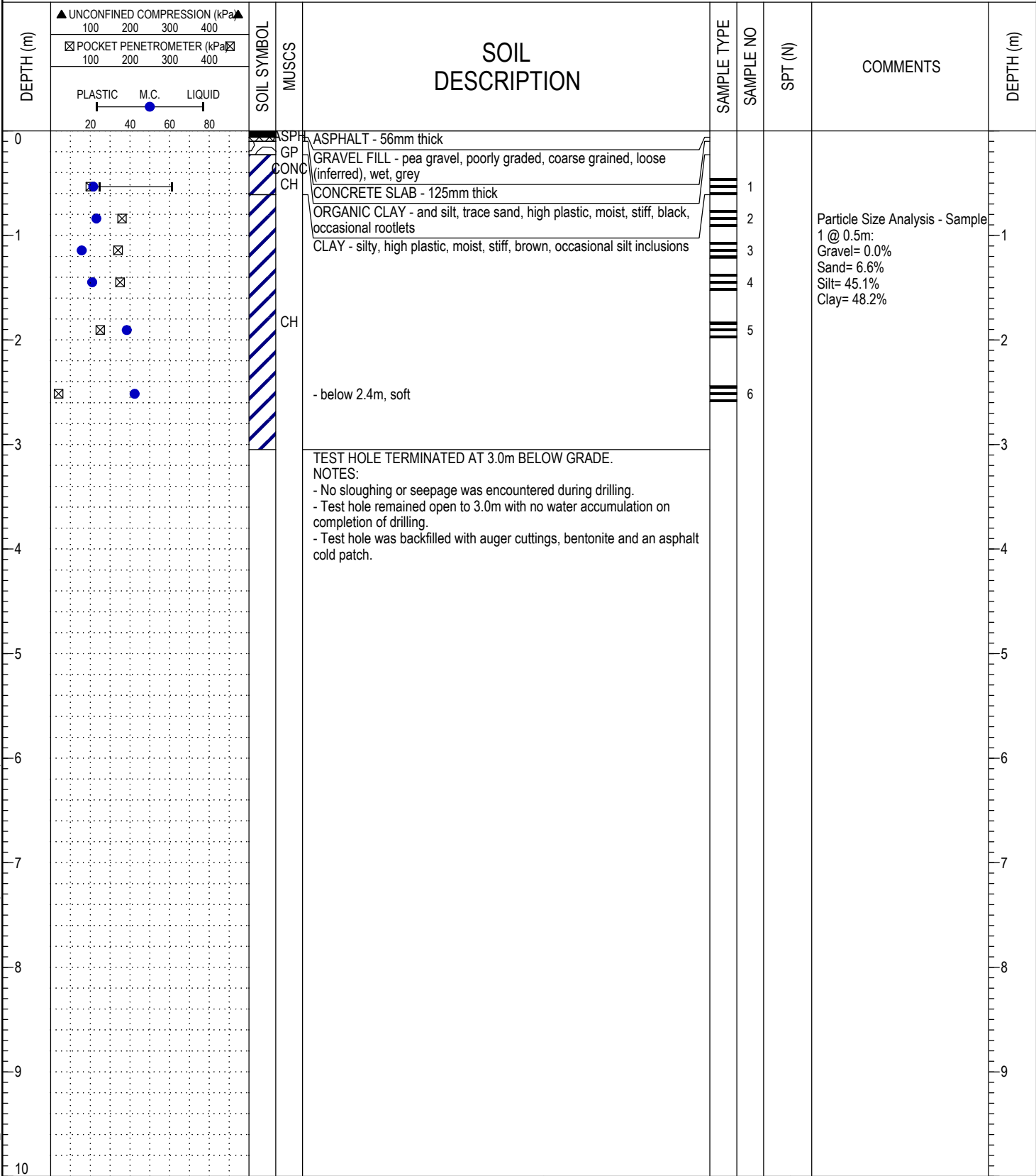

WX19175 - DILLON\_RILEY\_STREET.R1.GPJ 20/10/09 02:46 PM (WPG - GEOTECH LOG 1)



**Wood Environment & Infrastructure Solutions**  
 a division of Wood Canada Limited

LOGGED BY: AL	COMPLETION DEPTH: 3 m
REVIEWED BY: JP	COMPLETION DATE: September 14, 2020
Figure No.	Sheet 1 of 1

PROJECT: City of Winnipeg Street Investigation	DRILLER: Maple Leaf Drilling Ltd.	TEST HOLE ID: <b>RIL-03</b>
CLIENT: Dillon Consulting	DRILL RIG: Truck Mounted B40	PROJECT No: WX19175
LOCATION: Riely Street, Winnipeg, MB	DRILL METHOD: 138mm Core & 125mm SSA	ELEVATION: Not Surveyed

SAMPLE TYPE	<input checked="" type="checkbox"/> Shelby Tube	<input type="checkbox"/> No Recovery	<input checked="" type="checkbox"/> SPT (N)	<input type="checkbox"/> Grab Sample	<input type="checkbox"/> Split-Pen	<input type="checkbox"/> Core
BACKFILL TYPE	<input checked="" type="checkbox"/> Bentonite	<input type="checkbox"/> Pea Gravel	<input checked="" type="checkbox"/> Drill Cuttings	<input type="checkbox"/> Grout	<input type="checkbox"/> Slough	<input type="checkbox"/> Sand

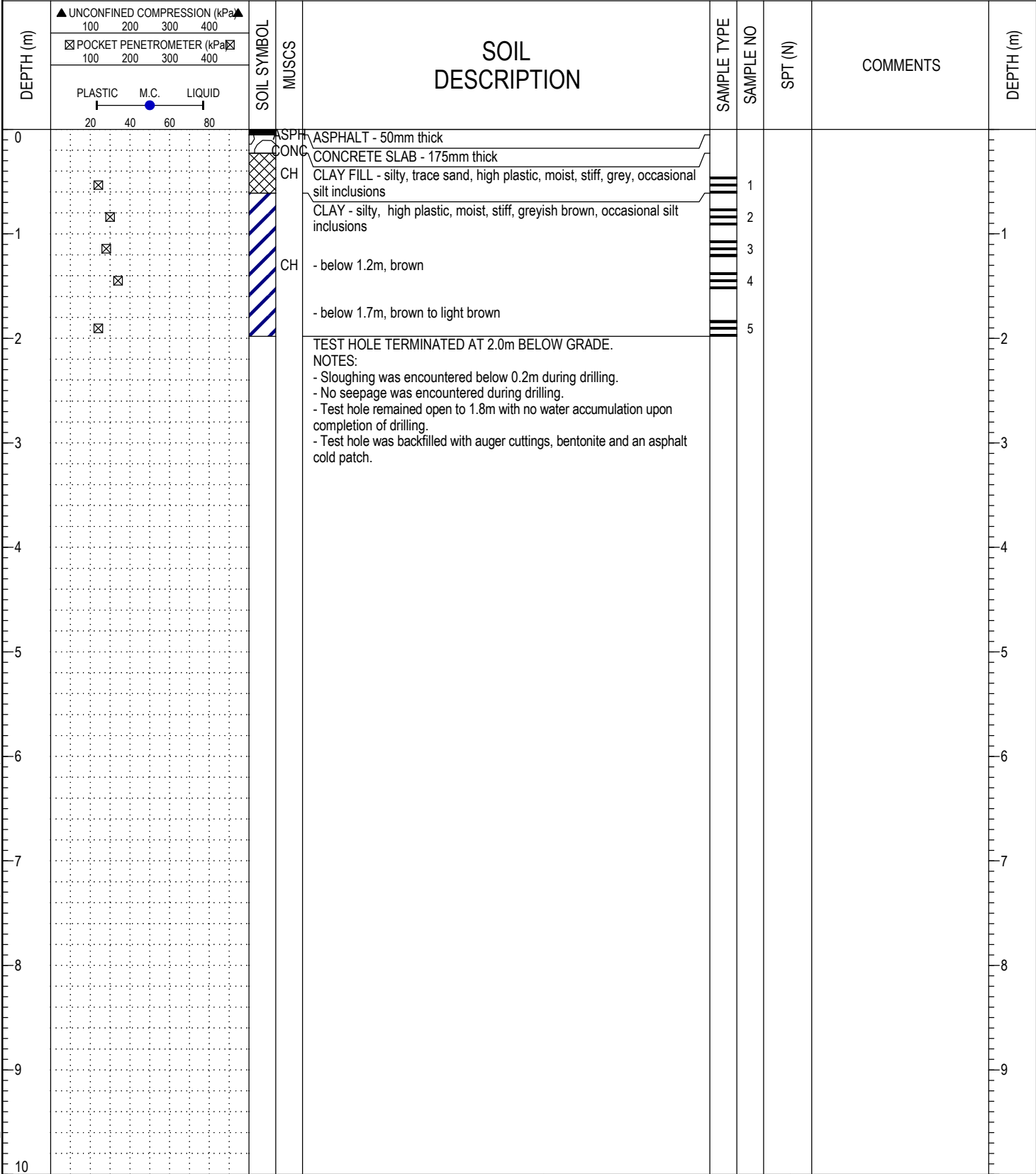

WX19175 - DILLON\_RILEY\_STREET.R1.GPJ 20/10/09 02:46 PM (WPG - GEOTECH LOG 1)



**Wood Environment & Infrastructure Solutions**  
a division of Wood Canada Limited

LOGGED BY: AL	COMPLETION DEPTH: 2 m
REVIEWED BY: JP	COMPLETION DATE: September 14, 2020
Figure No.	Sheet 1 of 1

PROJECT: City of Winnipeg Street Investigation	DRILLER: Maple Leaf Drilling Ltd.	TEST HOLE ID: <b>RIL-04</b>
CLIENT: Dillon Consulting	DRILL RIG: Truck Mounted B40	PROJECT No: WX19175
LOCATION: Riely Street, Winnipeg, MB	DRILL METHOD: 138mm Core & 125mm SSA	ELEVATION: Not Surveyed

SAMPLE TYPE	<input checked="" type="checkbox"/> Shelby Tube	<input type="checkbox"/> No Recovery	<input checked="" type="checkbox"/> SPT (N)	<input type="checkbox"/> Grab Sample	<input type="checkbox"/> Split-Pen	<input type="checkbox"/> Core
BACKFILL TYPE	<input checked="" type="checkbox"/> Bentonite	<input type="checkbox"/> Pea Gravel	<input checked="" type="checkbox"/> Drill Cuttings	<input type="checkbox"/> Grout	<input type="checkbox"/> Slough	<input type="checkbox"/> Sand

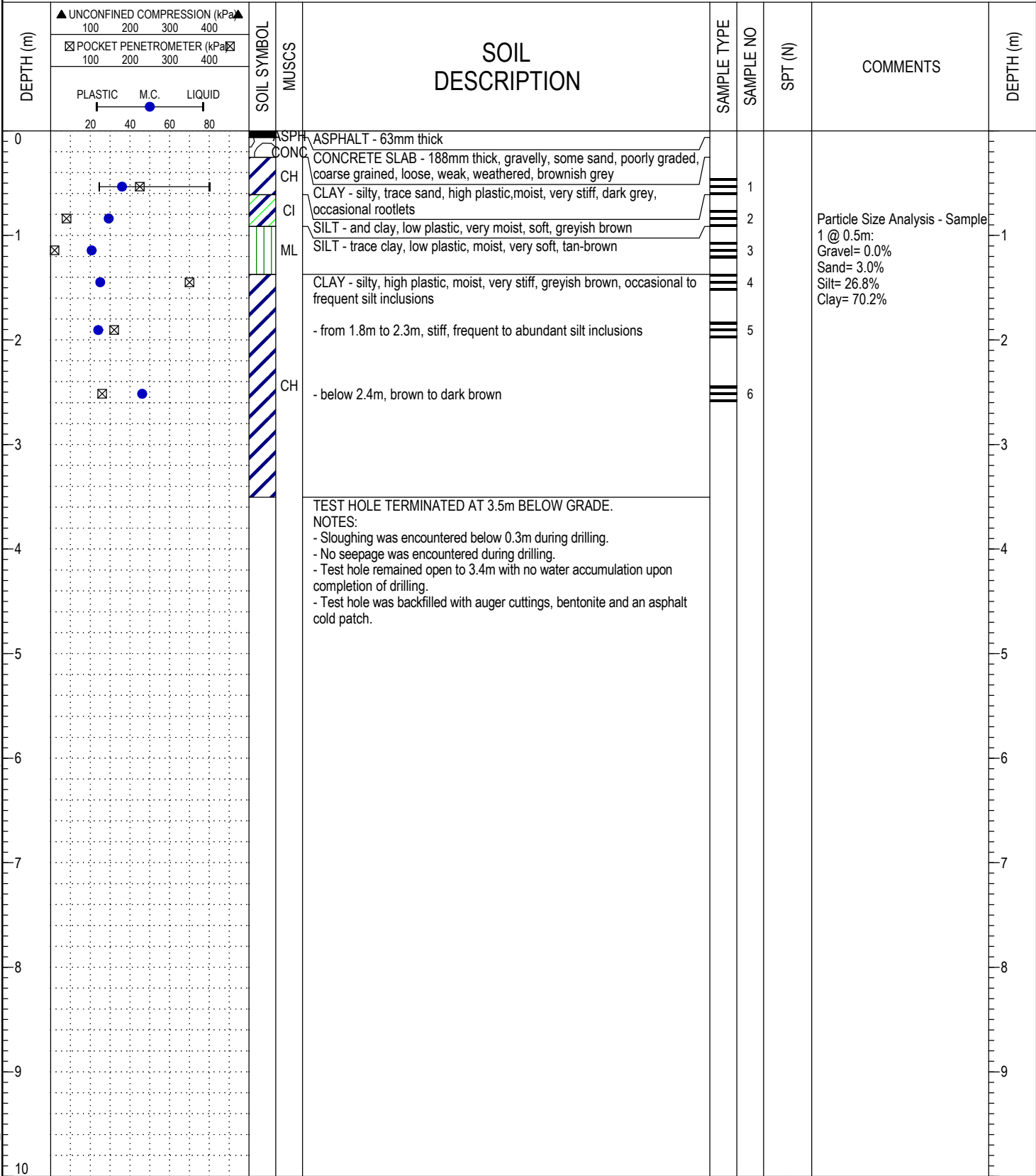

WX19175 - DILLON\_RILEY\_STREET.R1.GPJ 20/10/09 02:46 PM (WPG - GEOTECH LOG 1)



**Wood Environment & Infrastructure Solutions**  
 a division of Wood Canada Limited

LOGGED BY: AL	COMPLETION DEPTH: 3.5 m
REVIEWED BY: JP	COMPLETION DATE: September 14, 2020
Figure No.	Sheet 1 of 1

# Appendix C

## Grosvenor Avenue 1

- Test Hole Location Plan
- Core Photos
- Test Hole Logs



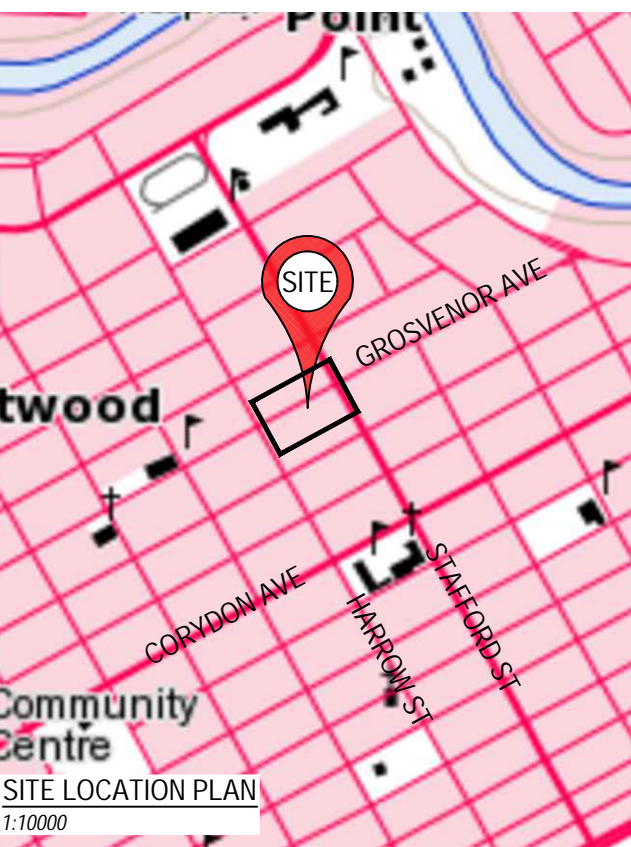

NOTES: SITE FEATURES AND LOCATIONS ARE APPROXIMATE ONLY. IMAGES FROM AUTODESK IMAGERY AND TOPO MAPS.

**LEGEND:**

TEST HOLE 

REVISION	BY	DATE
----	----	----

CLIENT:

DILLON CONSULTING LTD.

**wood.**

440 DOVERCOURT DRIVE  
WINNIPEG, MANITOBA R3Y 1N4  
PHONE: 204.488.2997 FAX:204.489.8261

DWN BY: MD

CHK'D BY: JP

DATUM: ---

PROJECTION: ---

SCALE: AS SHOWN

CITY OF WINNIPEG STREET INVESTIGATION  
PROJECT 21-R-05  
WINNIPEG, MANITOBA

SITE AND TEST HOLE LOCATION PLAN -  
GROSVENOR AVENUE FROM HARROW STREET TO STAFFORD STREET

DATE: OCTOBER 2020

PROJECT NO: WX19175

REV. NO.: A

FIGURE NO: FIGURE 1



GRO1-01: Intact Core, Plan View



GRO1-01: Intact Core, Profile View



GRO1-02: Asphalt Layer, Plan View



GRO1-02: Asphalt Layer, Profile View

	<p><b>CORE PHOTOGRAPHS</b>  <b>GROSVENOR AVENUE BETWEEN HARROW STREET AND</b>  <b>STAFFORD STREET</b>  <b>WINNIPEG, MANITOBA</b></p>
---	--

<p><b>Wood Environment and</b>  <b>Infrastructure Solutions</b></p>	<p><b>DILLON CONSULTING LTD.</b></p>
---	--------------------------------------

<p>Drawn: AL</p>	<p>Scale: N/A</p>	<p>Date: 09 October 2020</p>	<p>Project No.: WX19175</p>	
------------------	-------------------	------------------------------	-----------------------------	--



GRO1-02: Concrete Layer, Plan View



GRO1-02: Concrete Layer, Profile View



GRO1-03: Asphalt Layer, Plan View



GRO1-03: Asphalt Layer, Profile View

	<p align="center"><b>CORE PHOTOGRAPHS GROSVENOR AVENUE BETWEEN HARROW STREET AND STAFFORD STREET WINNIPEG, MANITOBA</b></p>		
<p><b>Wood Environment and Infrastructure Solutions</b></p>	<p align="center"><b>DILLON CONSULTING LTD.</b></p>		
<p>Drawn: AL</p>	<p>Scale: N/A</p>	<p>Date: 09 October 2020</p>	<p>Project No.: WX19175</p>



GRO1-03: Concrete Layer, Plan View



GRO1-03: Concrete Layer, Profile View

PROJECT: City of Winnipeg Street Investigation	DRILLER: Maple Leaf Drilling Ltd.	TEST HOLE ID: <b>GROS1-01</b>
CLIENT: Dillon Consulting	DRILL RIG: Truck Mounted B40	PROJECT No: WX19175
LOCATION: Grosvenor Avenue 1, Winnipeg, MB	DRILL METHOD: 138mm Core & 125mm SSA	ELEVATION: Not Surveyed

SAMPLE TYPE	<input checked="" type="checkbox"/> Shelby Tube	<input type="checkbox"/> No Recovery	<input checked="" type="checkbox"/> SPT (N)	<input type="checkbox"/> Grab Sample	<input type="checkbox"/> Split-Pen	<input type="checkbox"/> Core
BACKFILL TYPE	<input checked="" type="checkbox"/> Bentonite	<input type="checkbox"/> Pea Gravel	<input checked="" type="checkbox"/> Drill Cuttings	<input type="checkbox"/> Grout	<input type="checkbox"/> Slough	<input type="checkbox"/> Sand

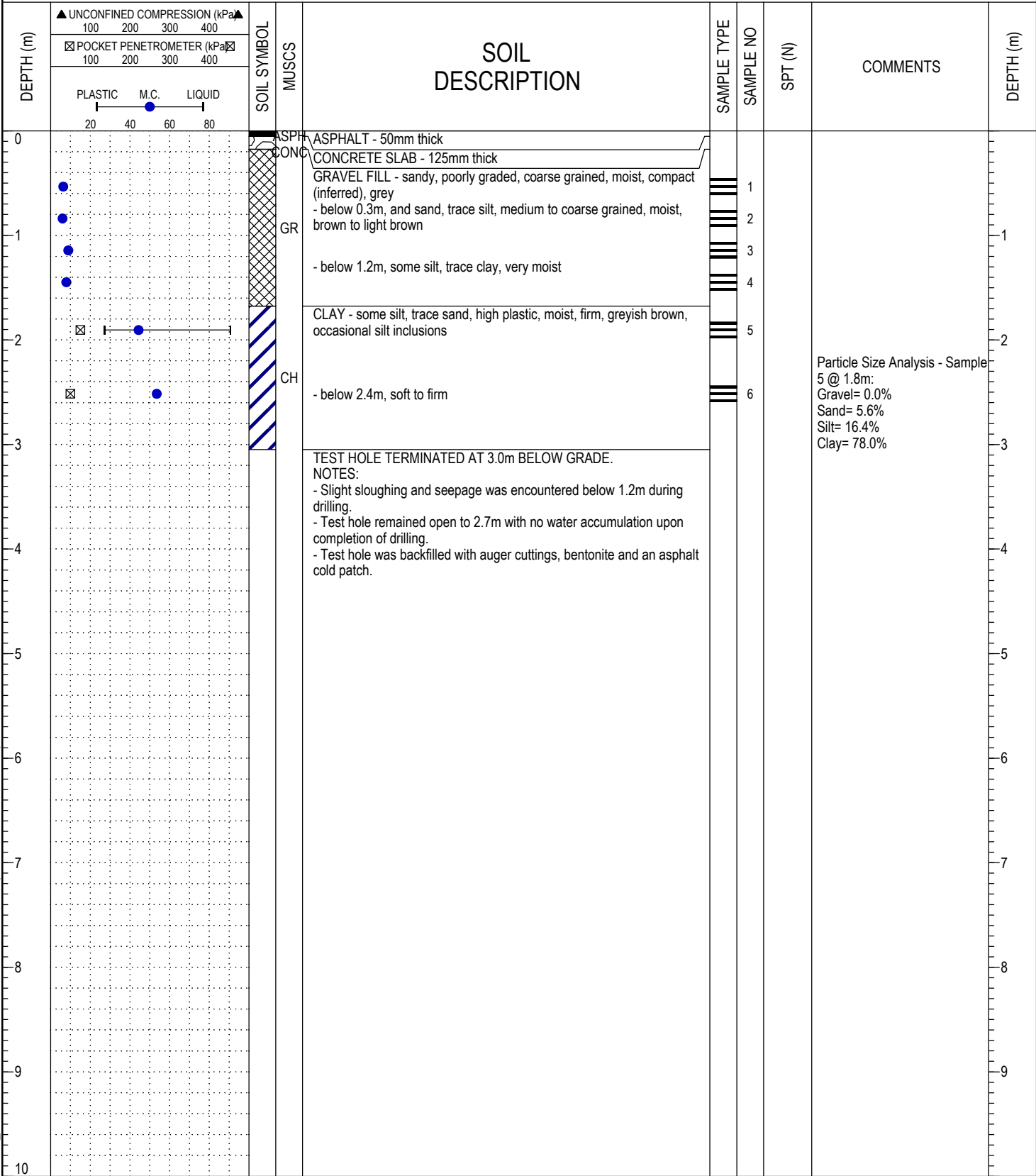

WX19175 - DILLON\_GROSVENOR AVE R1.GPJ 20/10/09 03:10 PM (MPG - GEOTECH LOG 1)



**Wood Environment & Infrastructure Solutions**  
a division of Wood Canada Limited

LOGGED BY: AL	COMPLETION DEPTH: 3 m
REVIEWED BY: JP	COMPLETION DATE: September 14, 2020
Figure No.	Sheet 1 of 1

PROJECT: City of Winnipeg Street Investigation	DRILLER: Maple Leaf Drilling Ltd.	TEST HOLE ID: <b>GROS1-02</b>
CLIENT: Dillon Consulting	DRILL RIG: Truck Mounted B40	PROJECT No: WX19175
LOCATION: Grosvenor Avenue 1, Winnipeg, MB	DRILL METHOD: 138mm Core & 125mm SSA	ELEVATION: Not Surveyed

SAMPLE TYPE	<input checked="" type="checkbox"/> Shelby Tube	<input type="checkbox"/> No Recovery	<input checked="" type="checkbox"/> SPT (N)	<input type="checkbox"/> Grab Sample	<input type="checkbox"/> Split-Pen	<input type="checkbox"/> Core
BACKFILL TYPE	<input checked="" type="checkbox"/> Bentonite	<input type="checkbox"/> Pea Gravel	<input checked="" type="checkbox"/> Drill Cuttings	<input type="checkbox"/> Grout	<input type="checkbox"/> Slough	<input type="checkbox"/> Sand

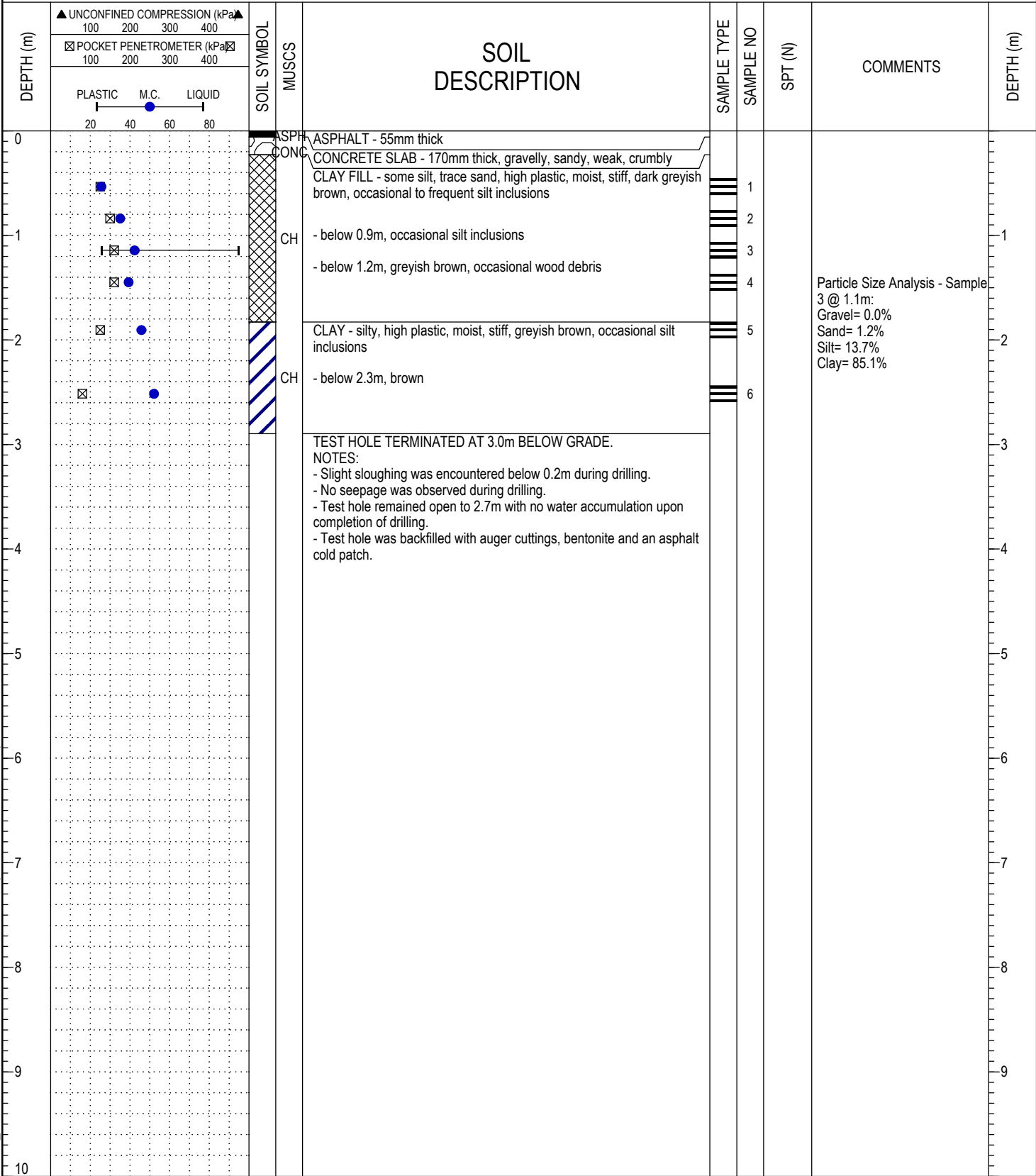

WX19175 - DILLON\_GROSVENOR AVE R1.GPJ 20/10/09 03:10 PM (MPG - GEOTECH LOG 1)



**Wood Environment & Infrastructure Solutions**  
 a division of Wood Canada Limited

LOGGED BY: AL	COMPLETION DEPTH: 2.9 m
REVIEWED BY: JP	COMPLETION DATE: September 14, 2020
Figure No.	Sheet 1 of 1

PROJECT: City of Winnipeg Street Investigation	DRILLER: Maple Leaf Drilling Ltd.	TEST HOLE ID: <b>GROS1-03</b>
CLIENT: Dillon Consulting	DRILL RIG: Truck Mounted B40	PROJECT No: WX19175
LOCATION: Grosvenor Avenue 1, Winnipeg, MB	DRILL METHOD: 138mm Core & 125mm SSA	ELEVATION: Not Surveyed

SAMPLE TYPE	<input checked="" type="checkbox"/> Shelby Tube	<input type="checkbox"/> No Recovery	<input checked="" type="checkbox"/> SPT (N)	<input type="checkbox"/> Grab Sample	<input type="checkbox"/> Split-Pen	<input type="checkbox"/> Core
BACKFILL TYPE	<input checked="" type="checkbox"/> Bentonite	<input type="checkbox"/> Pea Gravel	<input checked="" type="checkbox"/> Drill Cuttings	<input type="checkbox"/> Grout	<input type="checkbox"/> Slough	<input type="checkbox"/> Sand

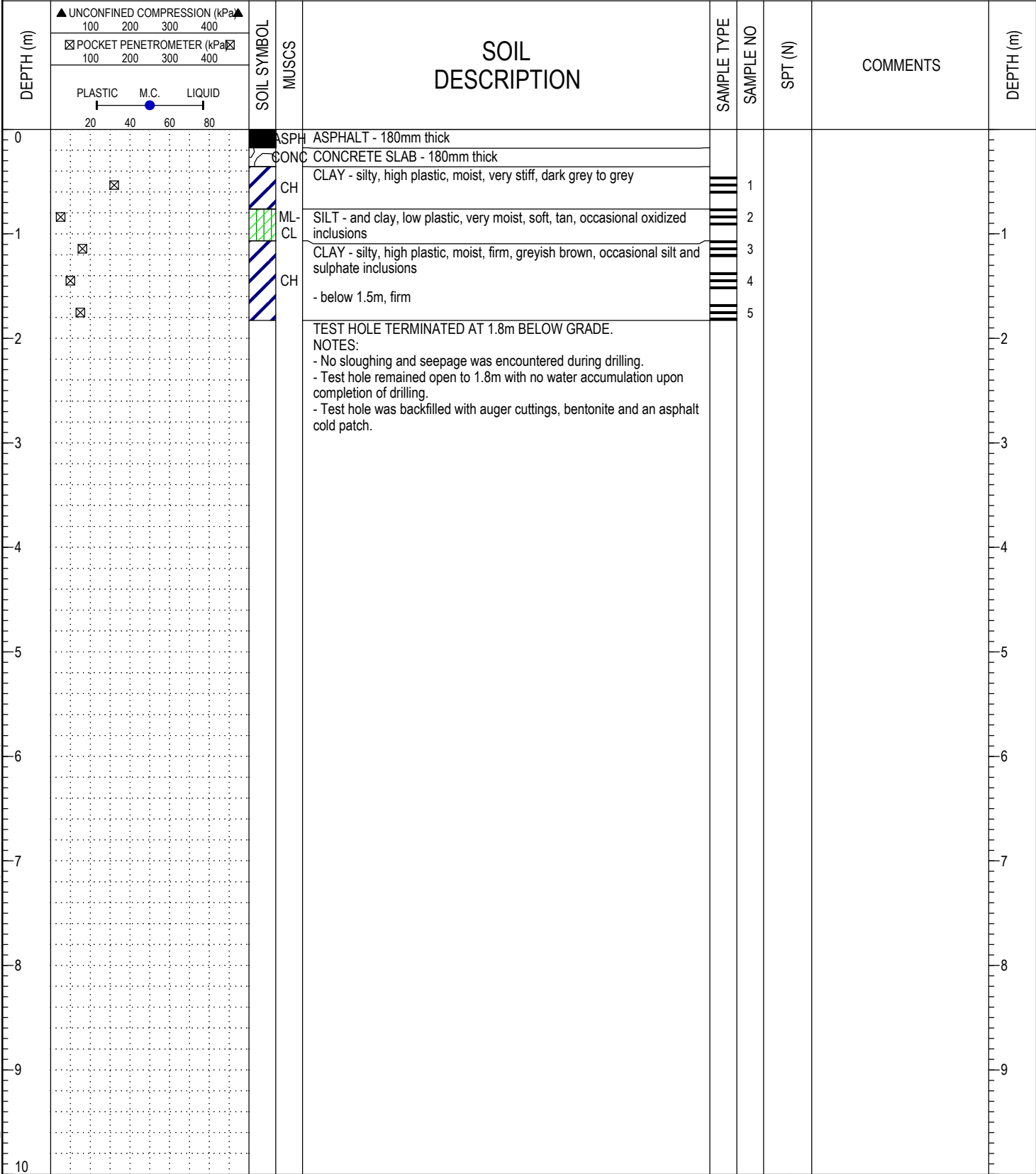

WX19175 - DILLON\_GROSVENOR AVE R1.GPJ 20/10/09 03:10 PM (MPG - GEOTECH LOG 1)



**Wood Environment & Infrastructure Solutions**  
a division of Wood Canada Limited

LOGGED BY: AL	COMPLETION DEPTH: 1.8 m
REVIEWED BY: JP	COMPLETION DATE: September 14, 2020
Figure No.	Sheet 1 of 1

# Appendix D

## Rockwood Alley

- Test Hole Location Plan
- Core Photos
- Test Hole Logs



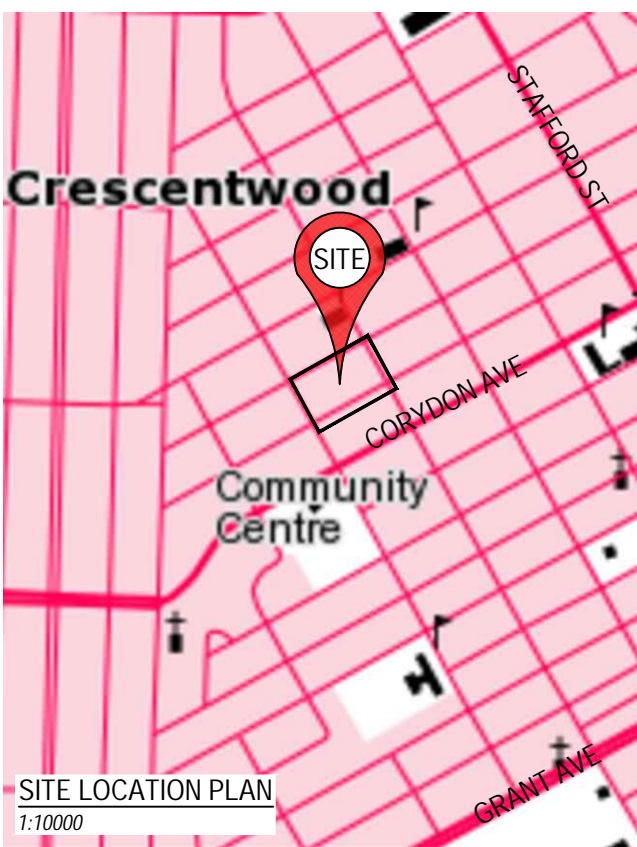
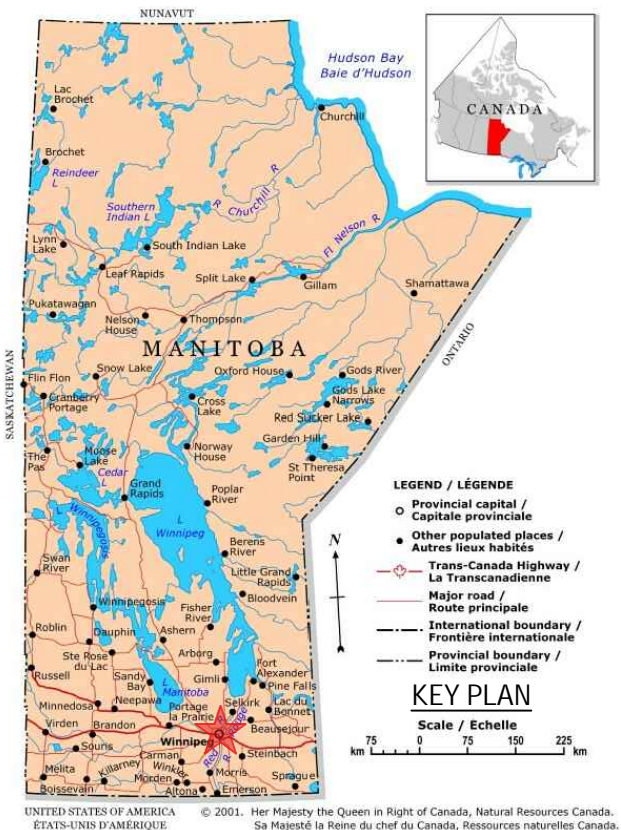

NOTES: SITE FEATURES AND LOCATIONS ARE APPROXIMATE ONLY. IMAGES FROM AUTODESK IMAGERY AND TOPO MAPS.

<b>LEGEND:</b> TEST HOLE	REVISION ----	BY ----	DATE ----	CLIENT:  <b>DILLON CONSULTING LTD.</b>	  440 DOVERCOURT DRIVE WINNIPEG, MANITOBA R3Y 1N4 PHONE: 204.488.2997 FAX:204.489.8261	DWN BY: MD	CITY OF WINNIPEG STREET INVESTIGATION PROJECT 21-R-05 WINNIPEG, MANITOBA	DATE: OCTOBER 2020
						CHK'D BY: JP		PROJECT NO.: WX19175
						DATUM: ---		REV. NO.: A
						PROJECTION: ---		FIGURE NO.: FIGURE 1
						SCALE: AS SHOWN		SITE AND TEST HOLE LOCATION PLAN - ALLEY FROM ROCKWOOD STREET TO WILTON STREET



ROCK-01: Intact Core, Plan View



ROCK-01: Intact Core, Profile View



ROCK-02: Intact Core, Plan View



ROCK-02: Intact Core, Profile View

	<p><b>CORE PHOTOGRAPHS</b>  <b>ROCKWOOD STREET ALLEY BOUNDED BY DORCHESTER</b>  <b>AVENUE, MCMILAN AVENUE AND WILTON STREET</b>  <b>WINNIPEG, MANITOBA</b></p>
---	--

<p><b>Wood Environment and Infrastructure Solutions</b></p>	<p><b>DILLON CONSULTING LTD.</b></p>
---	--------------------------------------

Drawn: AL	Scale: N/A	Date: 09 October 2020	Project No.: WX19175	
-----------	------------	-----------------------	----------------------	--

PROJECT: City of Winnipeg Street Investigation	DRILLER: Maple Leaf Drilling Ltd.	TEST HOLE ID: <b>ROCK-01</b>
CLIENT: Dillon Consulting	DRILL RIG: Truck Mounted B40	PROJECT No: WX19175
LOCATION: Rockwood Back Alley, Winnipeg, MB	DRILL METHOD: 138mm Core & 125mm Solid Stem Auger	ELEVATION: Not Surveyed

SAMPLE TYPE	<input checked="" type="checkbox"/> Shelby Tube	<input type="checkbox"/> No Recovery	<input checked="" type="checkbox"/> SPT (N)	<input type="checkbox"/> Grab Sample	<input type="checkbox"/> Split-Pen	<input type="checkbox"/> Core
BACKFILL TYPE	<input checked="" type="checkbox"/> Bentonite	<input type="checkbox"/> Pea Gravel	<input checked="" type="checkbox"/> Drill Cuttings	<input type="checkbox"/> Grout	<input type="checkbox"/> Slough	<input type="checkbox"/> Sand

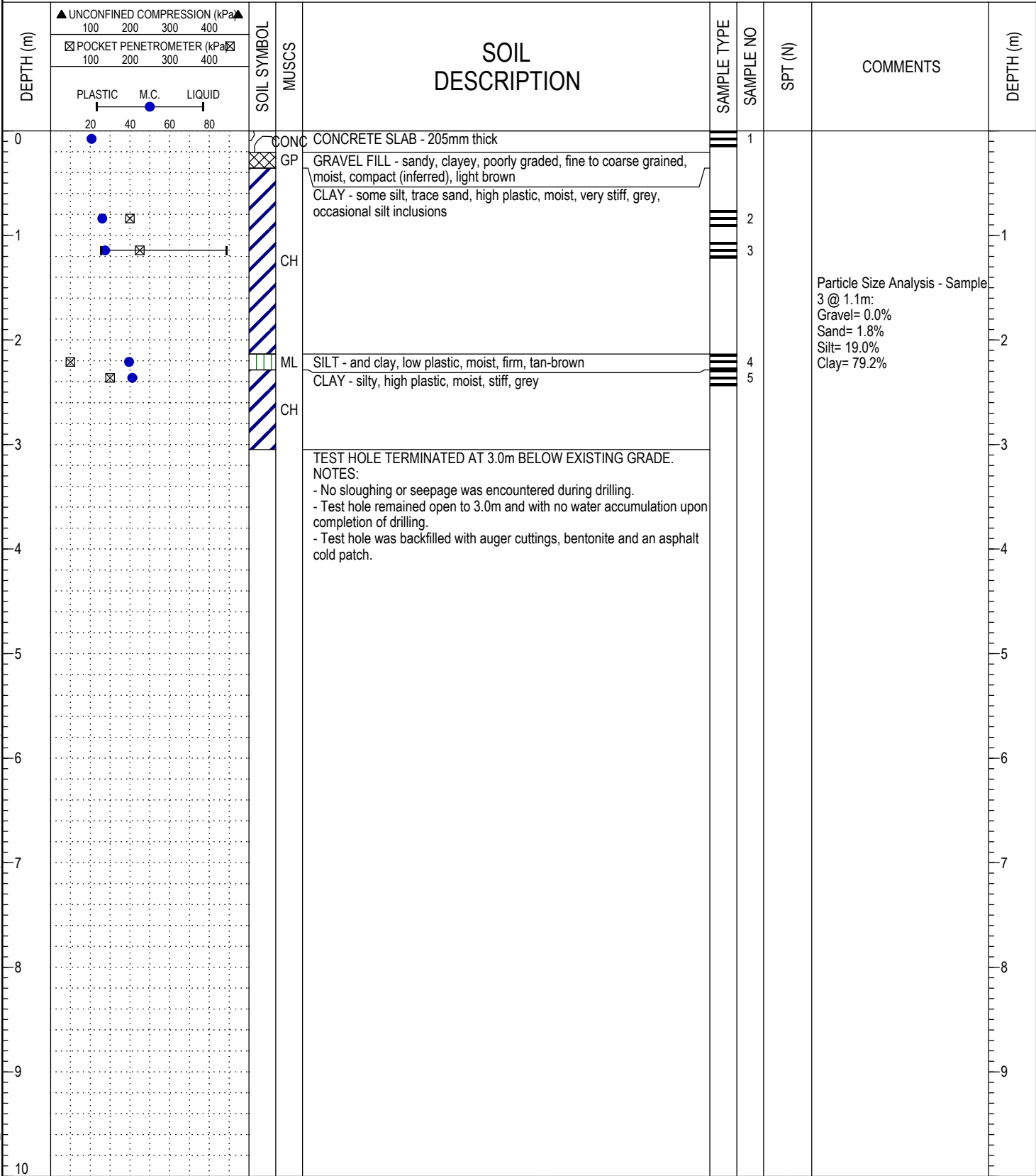

WX19175 - DILLON ROCKWOOD ALLEY R1.GPJ 20/10/09 01:25 PM (MPG - GEOTECH LOG 1)



**Wood Environment & Infrastructure Solutions**  
 a division of Wood Canada Limited

LOGGED BY: JP	COMPLETION DEPTH: 3 m
REVIEWED BY: JP	COMPLETION DATE: September 27, 2020
Figure No.	Sheet 1 of 1

PROJECT: City of Winnipeg Street Investigation	DRILLER: Maple Leaf Drilling Ltd.	TEST HOLE ID: <b>ROCK-02</b>
CLIENT: Dillon Consulting	DRILL RIG: Truck Mounted B40	PROJECT No: WX19175
LOCATION: Rockwood Back Alley, Winnipeg, MB	DRILL METHOD: 138mm Core & 125mm Solid Stem Auger	ELEVATION: Not Surveyed

SAMPLE TYPE	<input checked="" type="checkbox"/> Shelby Tube	<input type="checkbox"/> No Recovery	<input checked="" type="checkbox"/> SPT (N)	<input type="checkbox"/> Grab Sample	<input type="checkbox"/> Split-Pen	<input type="checkbox"/> Core
BACKFILL TYPE	<input checked="" type="checkbox"/> Bentonite	<input type="checkbox"/> Pea Gravel	<input checked="" type="checkbox"/> Drill Cuttings	<input type="checkbox"/> Grout	<input type="checkbox"/> Slough	<input type="checkbox"/> Sand

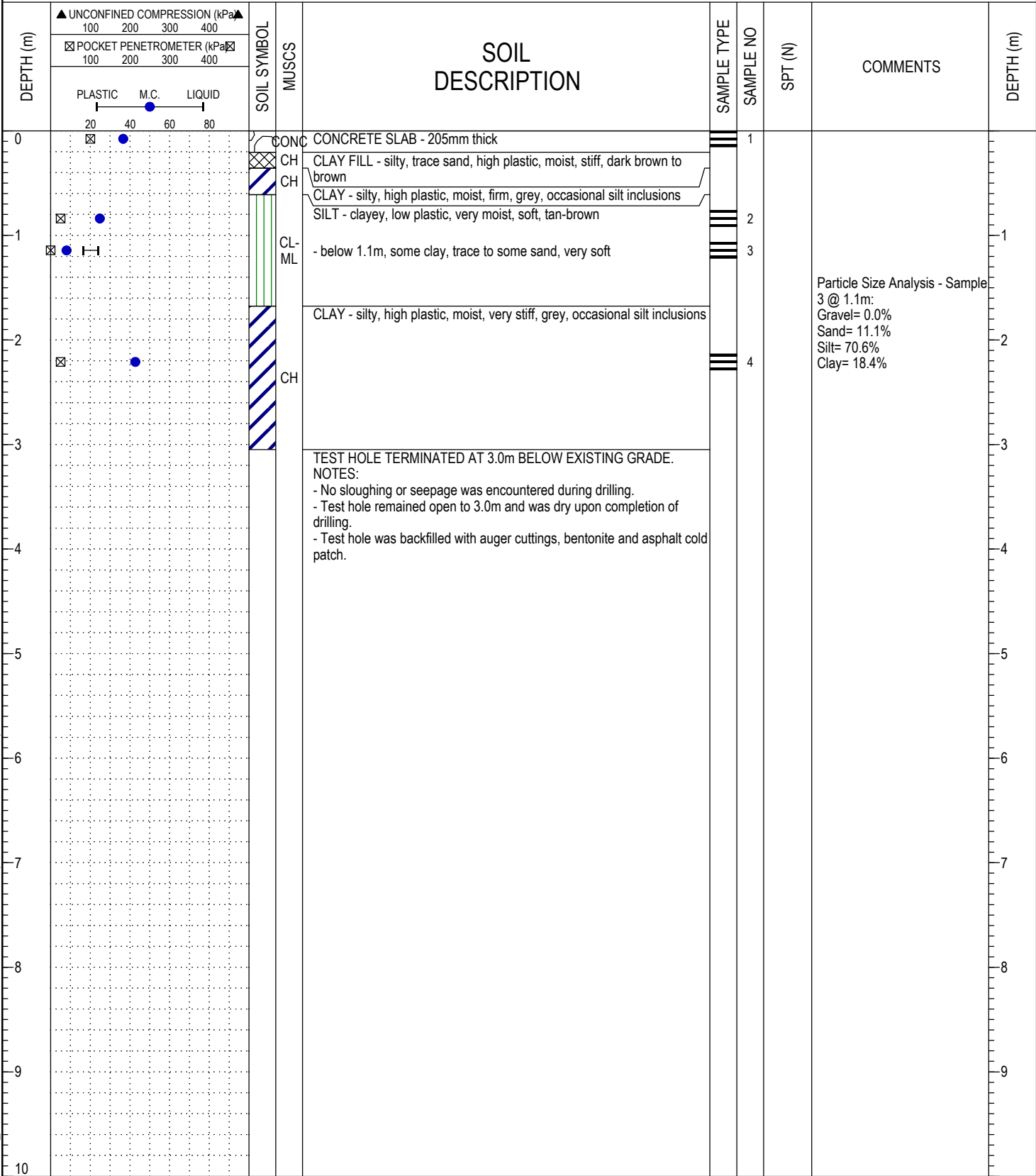

WX19175 - DILLON ROCKWOOD ALLEY R1.GPJ 20/10/09 01:26 PM (MPG - GEOTECH LOG 1)



**Wood Environment & Infrastructure Solutions**  
 a division of Wood Canada Limited

LOGGED BY: JP	COMPLETION DEPTH: 3 m
REVIEWED BY: JP	COMPLETION DATE: September 27, 2020
Figure No.	Sheet 1 of 1

# Appendix E

## Harvard Alley

- Test Hole Location Plan
- Core Photos
- Test Hole Logs

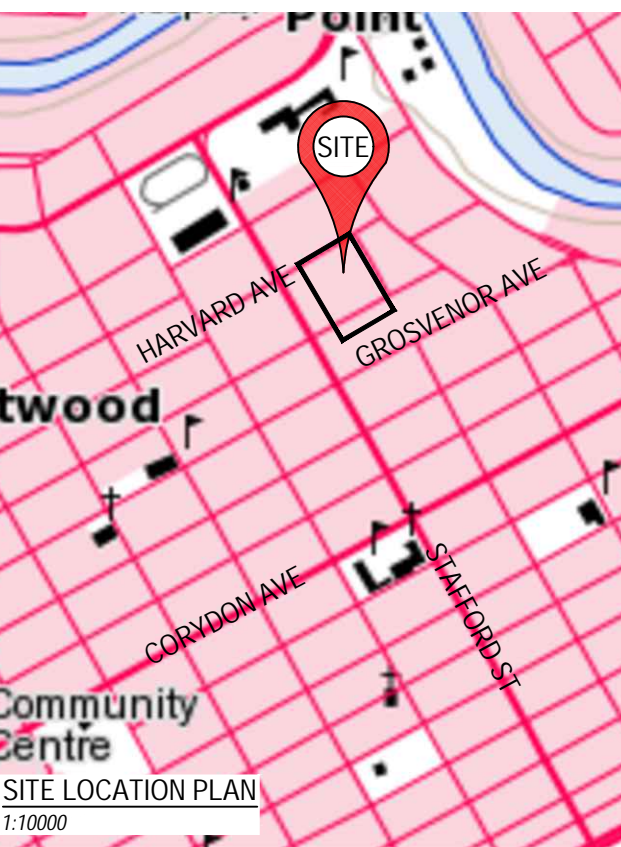
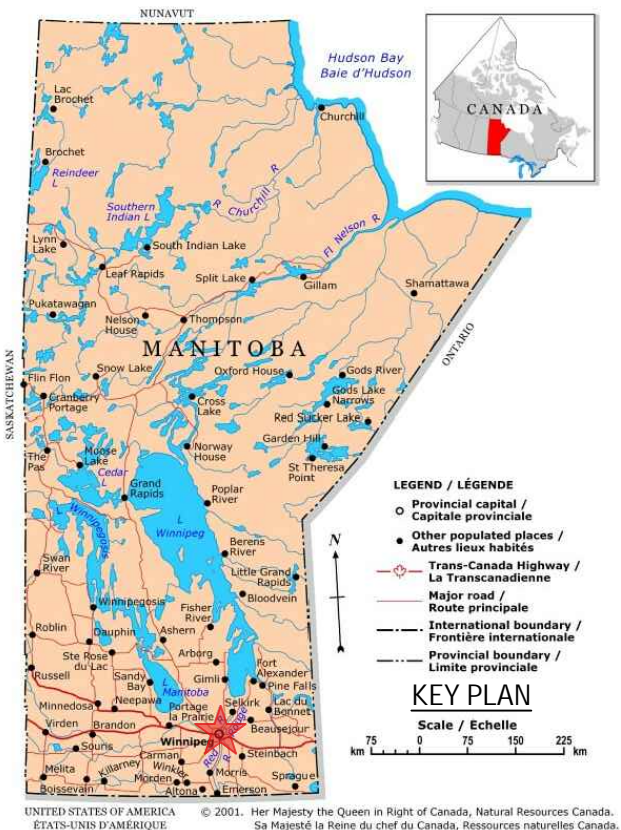

NOTES: SITE FEATURES AND LOCATIONS ARE APPROXIMATE ONLY. IMAGES FROM AUTODESK IMAGERY AND TOPO MAPS.

**LEGEND:**

TEST HOLE

REVISION	BY	DATE
----	----	----

CLIENT:

DILLON CONSULTING LTD.

**wood.**

440 DOVERCOURT DRIVE  
WINNIPEG, MANITOBA R3Y 1N4  
PHONE: 204.488.2997 FAX: 204.489.8261

DWN BY: MD  
CHK'D BY: JP  
DATUM: ---  
PROJECTION: ---  
SCALE: AS SHOWN

CITY OF WINNIPEG STREET INVESTIGATION  
PROJECT 21-R-05  
WINNIPEG, MANITOBA

SITE AND TEST HOLE LOCATION PLAN -  
ALLEY FROM YALE STREET TO HARVARD STREET

DATE: OCTOBER 2020  
PROJECT NO: WX19175  
REV. NO.: A  
FIGURE NO: FIGURE 1



HAR-01: Intact Core, Plan View



HAR-01: Intact Core, Profile View

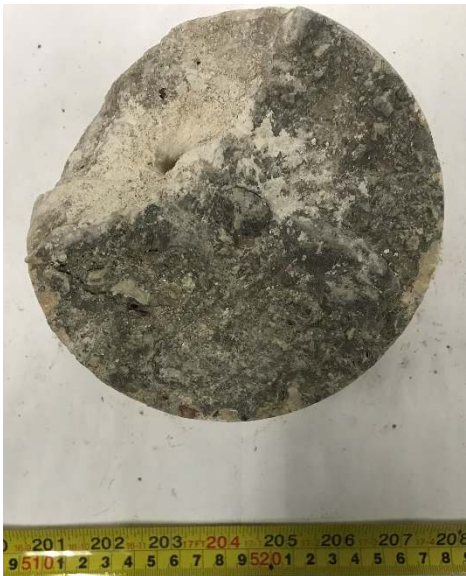

HAR-02: Intact Core, Plan View



HAR-02: Intact Core, Profile View

	<p><b>CORE PHOTOGRAPHS</b>  <b>HARVARD AVENUE ALLEY BOUNDED BY STAFFORD STREET,</b>  <b>AVONHERST STREET AND YALE AVENUE</b>  <b>WINNIPEG, MANITOBA</b></p>			
<p><b>Wood Environment and Infrastructure Solutions</b></p>	<p><b>DILLON CONSULTING LTD.</b></p>			
<p>Drawn: AL</p>	<p>Scale: N/A</p>	<p>Date: 09 October 2020</p>	<p>Project No.: WX19175</p>	

PROJECT: City of Winnipeg Street Investigation	DRILLER: Maple Leaf Drilling Ltd.	TEST HOLE ID: HAR-01
CLIENT: Dillon Consulting	DRILL RIG: Truck Mounted B40	PROJECT No: WX19175
LOCATION: Harvard Back Alley, Winnipeg, MB	DRILL METHOD: 138mm Core & 125mm SSA	ELEVATION: Not Surveyed

SAMPLE TYPE	<input checked="" type="checkbox"/> Shelby Tube	<input type="checkbox"/> No Recovery	<input checked="" type="checkbox"/> SPT (N)	<input type="checkbox"/> Grab Sample	<input type="checkbox"/> Split-Pen	<input type="checkbox"/> Core
BACKFILL TYPE	<input checked="" type="checkbox"/> Bentonite	<input type="checkbox"/> Pea Gravel	<input checked="" type="checkbox"/> Drill Cuttings	<input type="checkbox"/> Grout	<input type="checkbox"/> Slough	<input type="checkbox"/> Sand

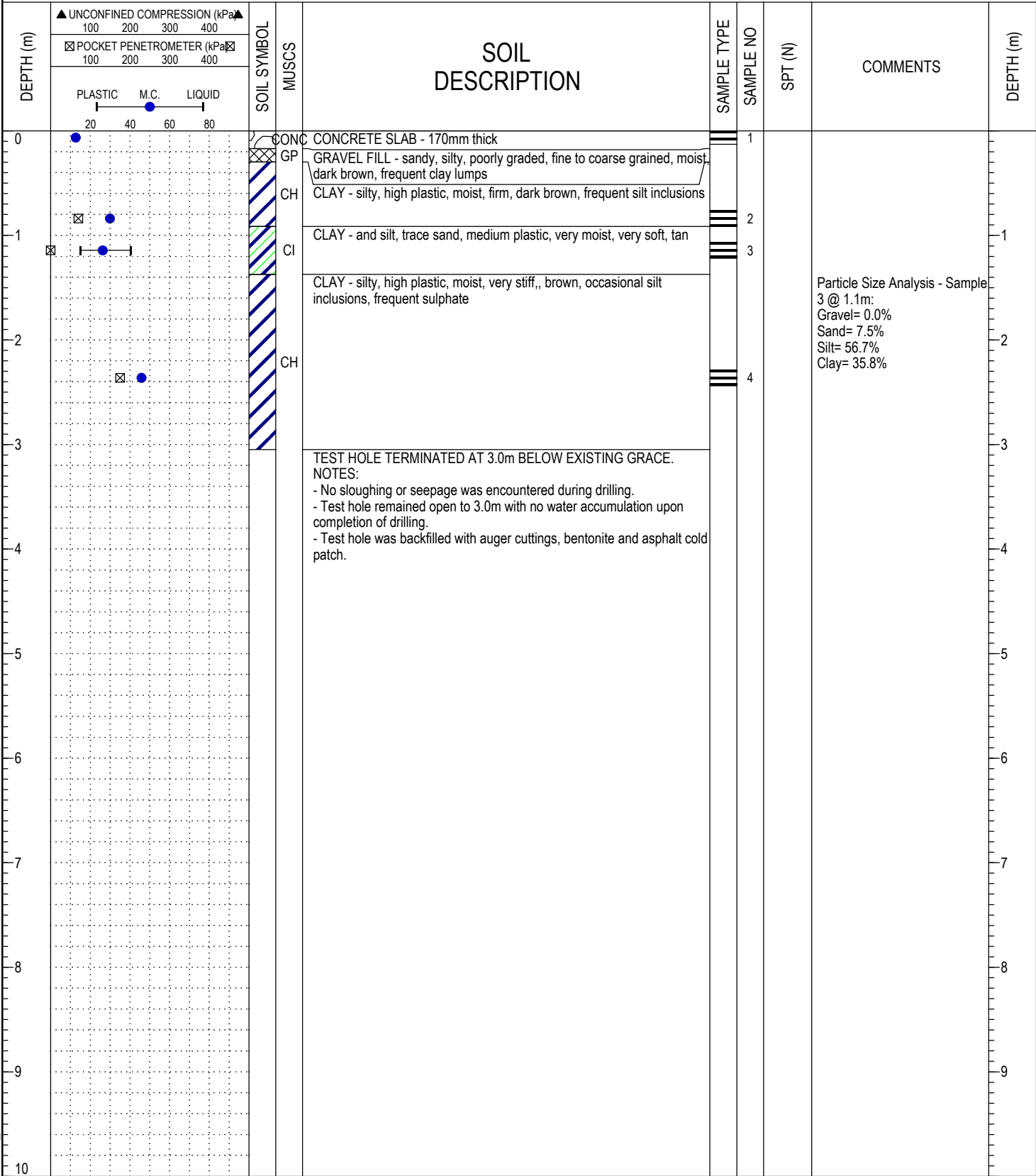

WX19175 - DILLON HARVARD ALLEY R1.GPJ 20/10/09 01:33 PM (WPG - GEOTECH LOG 1)



**Wood Environment & Infrastructure Solutions**  
a division of Wood Canada Limited

LOGGED BY: JP	COMPLETION DEPTH: 3 m
REVIEWED BY: JP	COMPLETION DATE:
Figure No.	Sheet 1 of 1



PROJECT: City of Winnipeg Street Investigation	DRILLER: Maple Leaf Drilling Ltd.	TEST HOLE ID: <b>HAR-02</b>
CLIENT: Dillon Consulting	DRILL RIG: Truck Mounted B40	PROJECT No: WX19175
LOCATION: Harvard Back Alley, Winnipeg, MB	DRILL METHOD: 138mm Core & 125mm SSA	ELEVATION: Not Surveyed

SAMPLE TYPE	<input checked="" type="checkbox"/> Shelby Tube	<input type="checkbox"/> No Recovery	<input checked="" type="checkbox"/> SPT (N)	<input type="checkbox"/> Grab Sample	<input type="checkbox"/> Split-Pen	<input type="checkbox"/> Core
BACKFILL TYPE	<input checked="" type="checkbox"/> Bentonite	<input type="checkbox"/> Pea Gravel	<input checked="" type="checkbox"/> Drill Cuttings	<input type="checkbox"/> Grout	<input type="checkbox"/> Slough	<input type="checkbox"/> Sand

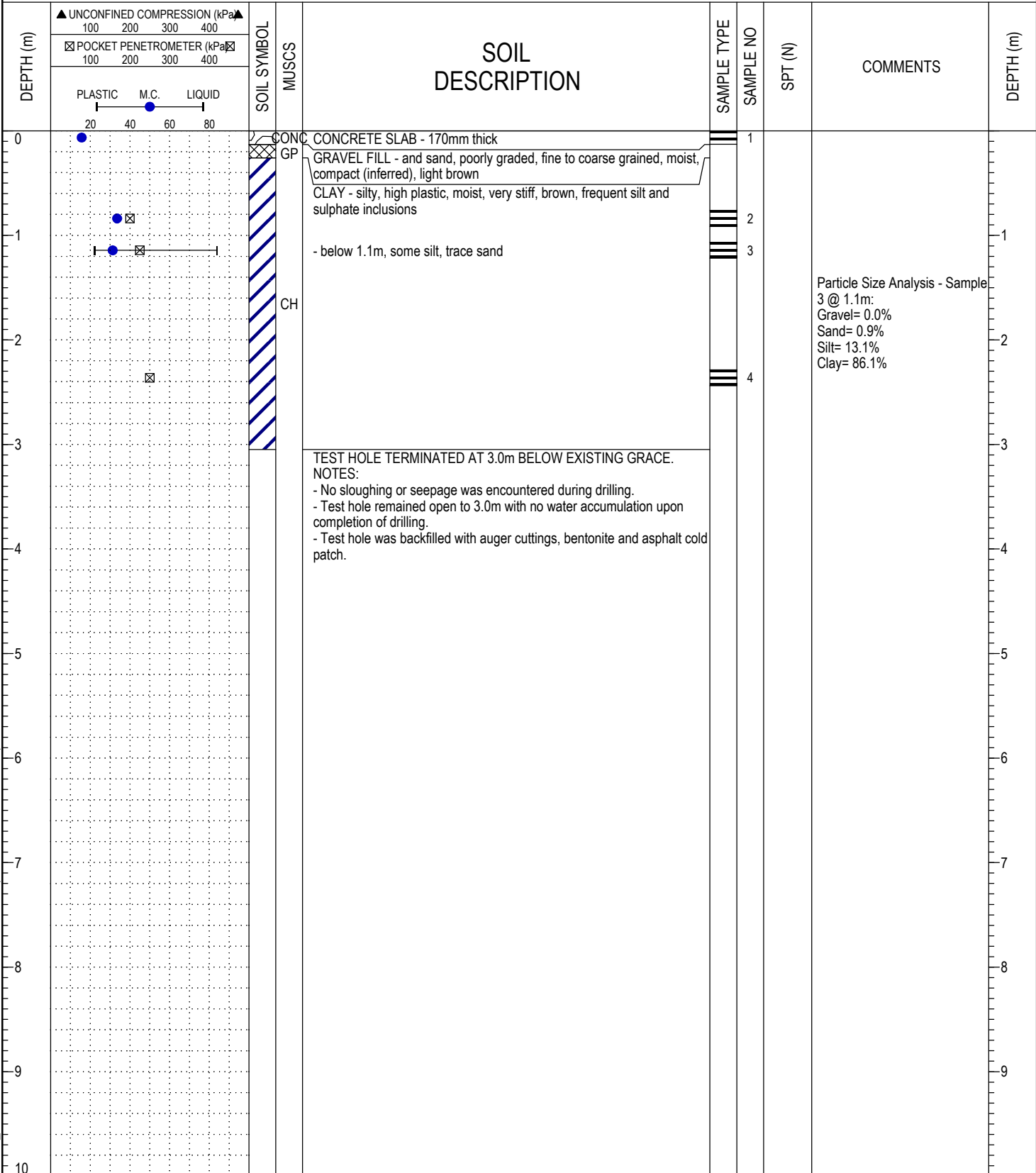

WX19175 - DILLON HARVARD ALLEY R1.GPJ 20/10/09 01:33 PM (WPG - GEOTECH LOG 1)



**Wood Environment & Infrastructure Solutions**  
 a division of Wood Canada Limited

LOGGED BY: JP	COMPLETION DEPTH: 3 m
REVIEWED BY: JP	COMPLETION DATE:
Figure No.	Sheet 1 of 1

# Appendix F

## Grosvenor Avenue 2

- Test Hole Location Plan
- Core Photos
- Test Hole Logs

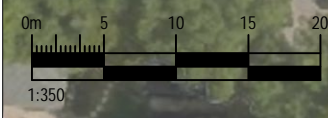
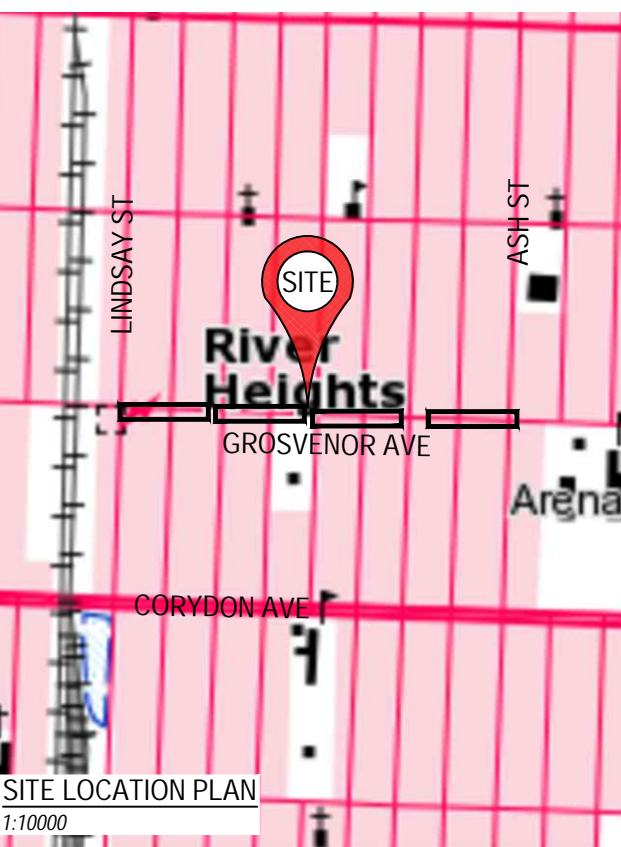
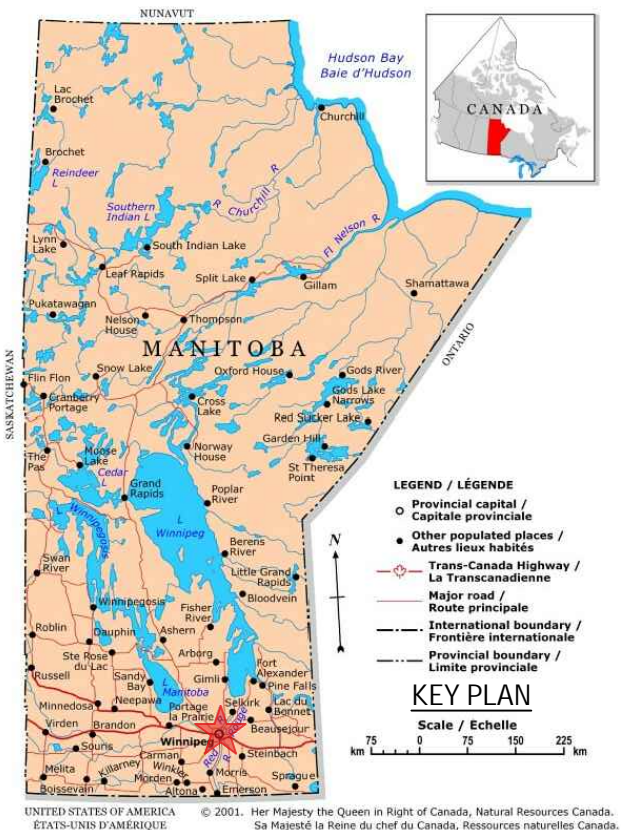

NOTES: SITE FEATURES AND LOCATIONS ARE APPROXIMATE ONLY. IMAGES FROM AUTODESK IMAGERY AND TOPO MAPS.

<b>LEGEND:</b> TEST HOLE	REVISION	BY	DATE	CLIENT:	 440 DOVERCOURT DRIVE WINNIPEG, MANITOBA R3Y 1N4 PHONE: 204.488.2997 FAX:204.489.8261	DWN BY:	CITY OF WINNIPEG STREET INVESTIGATION PROJECT 21-R-05 WINNIPEG, MANITOBA	DATE:
	----	----	----			OCTOBER 2020		
						PROJECT NO:		
						WX19175		
						REV. NO.:		
			A	FIGURE NO:		AS SHOWN	SITE AND TEST HOLE LOCATION PLAN - GROSVENOR AVENUE FROM LINDSAY STREET TO ASH STREET	FIGURE 1



GRO2-01: Intact Core, Plan View



GRO2-01: Intact Core, Profile View



GRO2-02: Intact Core, Plan View



GRO2-02: Intact Core, Profile View

	<p><b>CORE PHOTOGRAPHS</b>  <b>GROSVENOR AVENUE BETWEEN ASH STREET AND LINDSAY STREET</b>  <b>WINNIPEG, MANITOBA</b></p>			
<p><b>Wood Environment and Infrastructure Solutions</b></p>	<p><b>DILLON CONSULTING LTD.</b></p>			
<p>Drawn: AL</p>	<p>Scale: N/A</p>	<p>Date: 09 October 2020</p>	<p>Project No.: WX19175</p>	



GRO2-03: Intact Core, Plan View



GRO2-03: Intact Core, Profile View



GRO2-04: Intact Core, Plan View



GRO2-04: Intact Core, Profile View

	<p><b>CORE PHOTOGRAPHS</b>  <b>GROSVENOR AVENUE BETWEEN ASH STREET AND LINDSAY STREET</b>  <b>WINNIPEG, MANITOBA</b></p>		
<p><b>Wood Environment and Infrastructure Solutions</b></p>	<p><b>DILLON CONSULTING LTD.</b></p>		
<p>Drawn: AL</p>	<p>Scale: N/A</p>	<p>Date: 09 October 2020</p>	<p>Project No.: WX19175</p>



GRO2-05: Intact Core, Plan View

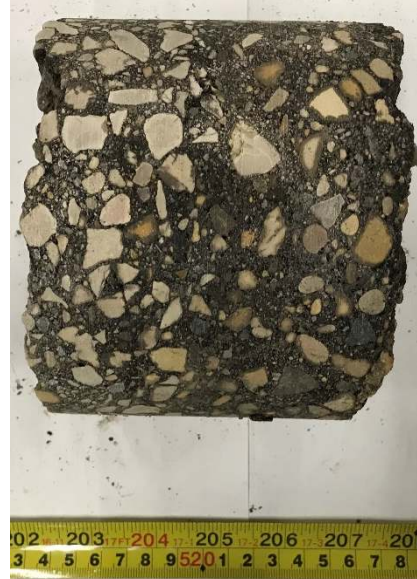

GRO2-05: Intact Core, Profile View



GRO2-06: Intact Core, Plan View



GRO2-06: Intact Core, Profile View

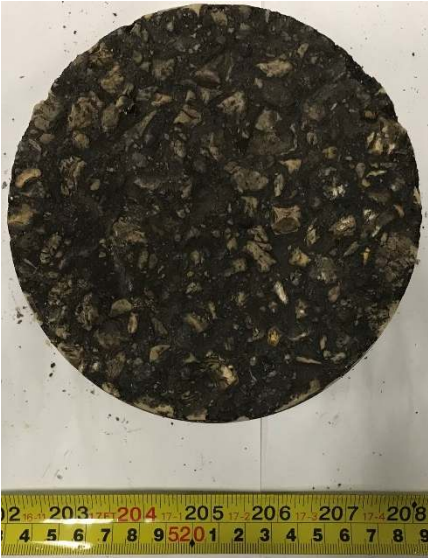

GRO2-07: Intact Core, Plan View



GRO2-07: Intact Core, Profile View



GRO2-08: Intact Core, Plan View



GRO2-08: Intact Core, Profile View



GRO2-09: Intact Core, Plan View



GRO2-09: Intact Core, Profile View

	<p align="center"><b>CORE PHOTOGRAPHS</b>  <b>GROSVENOR AVENUE BETWEEN ASH STREET AND LINDSAY STREET</b>  <b>WINNIPEG, MANITOBA</b></p>		
<p><b>Wood Environment and Infrastructure Solutions</b></p>	<p align="center"><b>DILLON CONSULTING LTD.</b></p>		
<p>Drawn: AL</p>	<p>Scale: N/A</p>	<p>Date: 09 October 2020</p>	<p>Project No.: WX19175</p>



PROJECT: City of Winnipeg Street Investigation	DRILLER: Maple Leaf Drilling Ltd.	TEST HOLE ID: <b>GROS2-01</b>
CLIENT: Dillon Consulting	DRILL RIG: Truck Mounted B40	PROJECT No: WX19175
LOCATION: Grosvenor Avenue 2, Winnipeg, MB	DRILL METHOD: 138mm Core & 125mm SSA	ELEVATION: Not Surveyed

SAMPLE TYPE	<input checked="" type="checkbox"/> Shelby Tube	<input type="checkbox"/> No Recovery	<input checked="" type="checkbox"/> SPT (N)	<input type="checkbox"/> Grab Sample	<input type="checkbox"/> Split-Pen	<input type="checkbox"/> Core
BACKFILL TYPE	<input checked="" type="checkbox"/> Bentonite	<input type="checkbox"/> Pea Gravel	<input checked="" type="checkbox"/> Drill Cuttings	<input type="checkbox"/> Grout	<input type="checkbox"/> Slough	<input type="checkbox"/> Sand

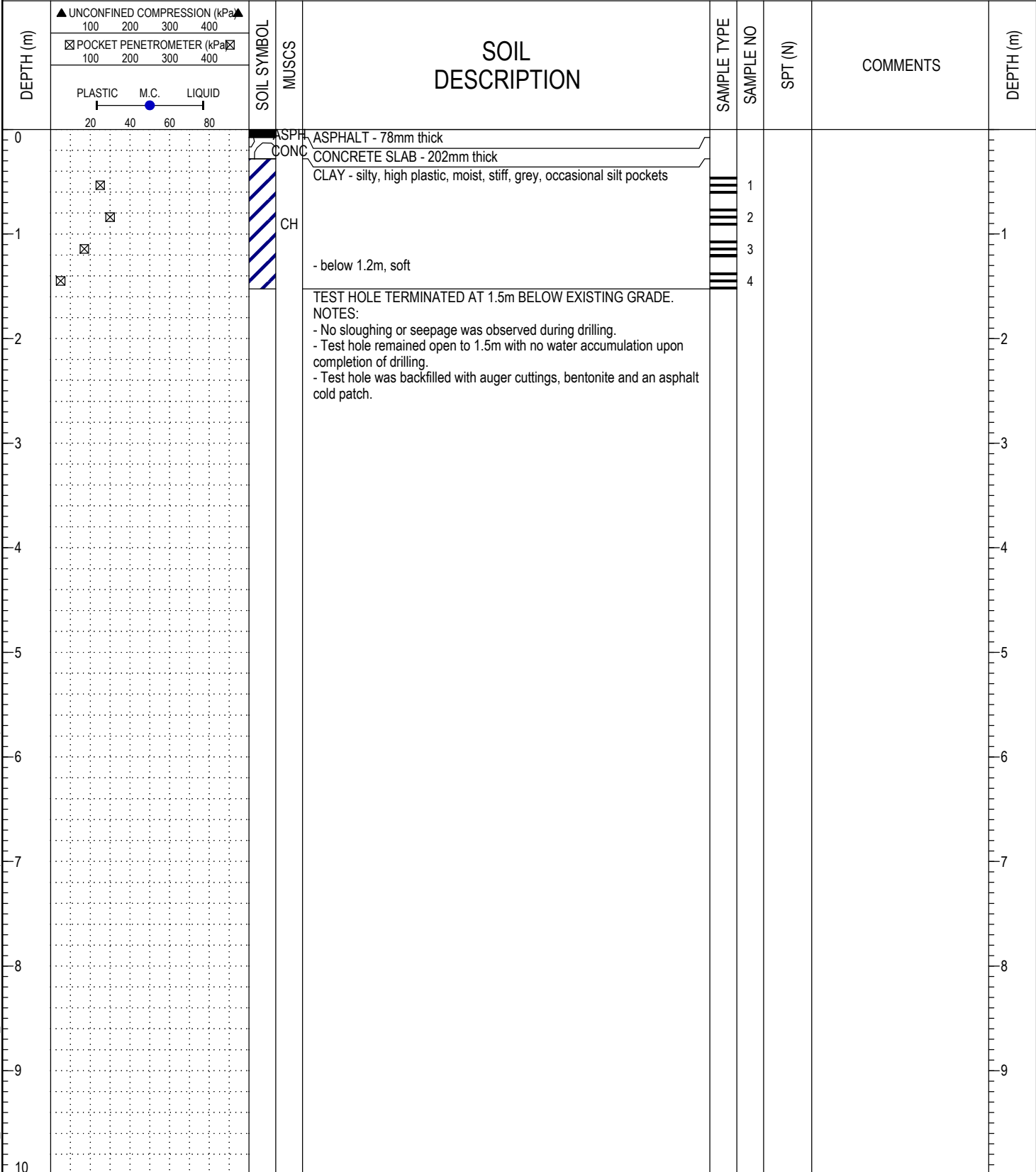

WX19175 - DILLON\_GROSVENOR AVE\_2\_R1.GPJ\_20/10/13 09:36 AM (WPG - GEOTECH LOG 1)



**Wood Environment & Infrastructure Solutions**  
 a division of Wood Canada Limited

LOGGED BY: JW	COMPLETION DEPTH: 1.5 m
REVIEWED BY: JP	COMPLETION DATE: March 10, 2020
Figure No.	Sheet 1 of 1

PROJECT: City of Winnipeg Street Investigation	DRILLER: Maple Leaf Drilling Ltd.	TEST HOLE ID: <b>GROS2-02</b>
CLIENT: Dillon Consulting	DRILL RIG: Truck Mounted B40	PROJECT No: WX19175
LOCATION: Grosvenor Avenue 2, Winnipeg, MB	DRILL METHOD: 138mm Core & 125mm SSA	ELEVATION: Not Surveyed

SAMPLE TYPE	<input checked="" type="checkbox"/> Shelby Tube	<input type="checkbox"/> No Recovery	<input checked="" type="checkbox"/> SPT (N)	<input type="checkbox"/> Grab Sample	<input type="checkbox"/> Split-Pen	<input type="checkbox"/> Core
BACKFILL TYPE	<input checked="" type="checkbox"/> Bentonite	<input type="checkbox"/> Pea Gravel	<input checked="" type="checkbox"/> Drill Cuttings	<input type="checkbox"/> Grout	<input type="checkbox"/> Slough	<input type="checkbox"/> Sand

DEPTH (m)	UNCONFINED COMPRESSION (kPa)		SOIL SYMBOL	MUSCS	SOIL DESCRIPTION	SAMPLE TYPE	SAMPLE NO	SPT (N)	COMMENTS	DEPTH (m)
	▲	□								
0	POCKET PENETROMETER (kPa) 100 200 300 400 PLASTIC M.C. LIQUID 20 40 60 80		ASPH		ASPHALT - 170mm thick					0
0			GP		GRAVEL FILL (LIMESTONE) - and sand, trace silt, poorly graded, fine to coarse grained, moist, compact (inferred), white to grey	Core	1			0
1					TEST HOLE TERMINATED AT 0.5m BELOW EXISTING GRADE. NOTES: - No sloughing or seepage was observed during drilling. - Test hole remained open to 0.5m with no water accumulation upon completion of drilling. - Test hole was backfilled with auger cuttings, bentonite and an asphalt cold patch.					1
2										2
3										3
4										4
5										5
6										6
7										7
8										8
9										9
10										10

WX19175 - DILLON\_GROSVENOR AVE\_2\_R1.GPJ\_20/10/13 09:37 AM (WPG - GEOTECH LOG 1)



Wood Environment & Infrastructure Solutions  
a division of Wood Canada Limited

LOGGED BY: JW	COMPLETION DEPTH: 0.5 m
REVIEWED BY: JP	COMPLETION DATE: March 10, 2020
Figure No.	Sheet 1 of 1

PROJECT: City of Winnipeg Street Investigation	DRILLER: Maple Leaf Drilling Ltd.	TEST HOLE ID: <b>GROS2-03</b>
CLIENT: Dillon Consulting	DRILL RIG: Truck Mounted B40	PROJECT No: WX19175
LOCATION: Grosvenor Avenue 2, Winnipeg, MB	DRILL METHOD: 138mm Core & 125mm SSA	ELEVATION: Not Surveyed

SAMPLE TYPE	<input checked="" type="checkbox"/> Shelby Tube	<input type="checkbox"/> No Recovery	<input checked="" type="checkbox"/> SPT (N)	<input type="checkbox"/> Grab Sample	<input type="checkbox"/> Split-Pen	<input type="checkbox"/> Core
-------------	---	--------------------------------------	---	--------------------------------------	------------------------------------	-------------------------------

BACKFILL TYPE	<input checked="" type="checkbox"/> Bentonite	<input type="checkbox"/> Pea Gravel	<input checked="" type="checkbox"/> Drill Cuttings	<input type="checkbox"/> Grout	<input type="checkbox"/> Slough	<input type="checkbox"/> Sand
---------------	---	-------------------------------------	--	--------------------------------	---------------------------------	-------------------------------

DEPTH (m)	UNCONFINED COMPRESSION (kPa)		SOIL SYMBOL	MUSCS	SOIL DESCRIPTION	SAMPLE TYPE	SAMPLE NO	SPT (N)	COMMENTS	DEPTH (m)
	▲	▲								
0	POCKET PENETROMETER (kPa) PLASTIC M.C. LIQUID 20 40 60 80		ASPH		ASPHALT - 64mm thick	Core	1			0
0.5			GP		GRAVEL FILL (LIMESTONE) - and sand, trace silt, poorly graded, fine to coarse grained, moist, compact (inferred), white	Core	2			0.5
1			CH		CLAY - silty, high plastic, moist, stiff, dark grey, occasional silt pockets					1
1.5					TEST HOLE TERMINATED AT 0.5m BELOW EXISTING GRADE.					1.5
2					NOTES: - No sloughing or seepage was observed during drilling. - Test hole remained open to 0.5m with no water accumulation upon completion of drilling. - Test hole was backfilled with auger cuttings, bentonite and asphalt cold patch.					2
3										3
4										4
5										5
6										6
7										7
8										8
9										9
10										10

WX19175 - DILLON\_GROSVENOR AVE\_2\_R1.GPJ 20/10/13 09:37 AM (WPG - GEOTECH LOG 1)



Wood Environment & Infrastructure Solutions  
a division of Wood Canada Limited

LOGGED BY: JW	COMPLETION DEPTH: 0.5 m
REVIEWED BY: JP	COMPLETION DATE: March 10, 2020
Figure No.	Sheet 1 of 1

PROJECT: City of Winnipeg Street Investigation	DRILLER: Maple Leaf Drilling Ltd.	TEST HOLE ID: <b>GROS2-04</b>
CLIENT: Dillon Consulting	DRILL RIG: Truck Mounted B40	PROJECT No: WX19175
LOCATION: Grosvenor Avenue 2, Winnipeg, MB	DRILL METHOD: 138mm Core & 125mm SSA	ELEVATION: Not Surveyed

SAMPLE TYPE	<input checked="" type="checkbox"/> Shelby Tube	<input type="checkbox"/> No Recovery	<input checked="" type="checkbox"/> SPT (N)	<input type="checkbox"/> Grab Sample	<input type="checkbox"/> Split-Pen	<input type="checkbox"/> Core
BACKFILL TYPE	<input checked="" type="checkbox"/> Bentonite	<input type="checkbox"/> Pea Gravel	<input checked="" type="checkbox"/> Drill Cuttings	<input type="checkbox"/> Grout	<input type="checkbox"/> Slough	<input type="checkbox"/> Sand

DEPTH (m)	UNCONFINED COMPRESSION (kPa)		SOIL SYMBOL	MUSCS	SOIL DESCRIPTION	SAMPLE TYPE	SAMPLE NO	SPT (N)	COMMENTS	DEPTH (m)
	▲	▲								
0	100	200	ASPH		ASPHALT - 80mm thick					0
0	100	200	GM		GRAVEL FILL - and sand, silty, poorly graded, fine to medium grained, damp, compact (inferred), brown to dark grey		1			0
0.5	TEST HOLE TERMINATED AT 0.5m BELOW EXISTING GRADE.									
0.5	NOTES:									
0.5	- No sloughing or seepage was observed during drilling.									
0.5	- Test hole remained open to 0.5m with no water accumulation upon completion of drilling.									
0.5	- Test hole was backfilled with auger cuttings, bentonite and an asphalt cold patch.									
1										1
2										2
3										3
4										4
5										5
6										6
7										7
8										8
9										9
10										10

WX19175 - DILLON\_GROSVENOR AVE\_2\_R1.GPJ\_20/10/13 09:37 AM (WPG - GEOTECH LOG 1)



**Wood Environment & Infrastructure Solutions**  
a division of Wood Canada Limited

LOGGED BY: JW	COMPLETION DEPTH: 0.5 m
REVIEWED BY: JP	COMPLETION DATE: March 10, 2020
Figure No.	Sheet 1 of 1

PROJECT: City of Winnipeg Street Investigation	DRILLER: Maple Leaf Drilling Ltd.	TEST HOLE ID: <b>GROS2-05</b>
CLIENT: Dillon Consulting	DRILL RIG: Truck Mounted B40	PROJECT No: WX19175
LOCATION: Grosvenor Avenue 2, Winnipeg, MB	DRILL METHOD: 138mm Core & 125mm SSA	ELEVATION: Not Surveyed

SAMPLE TYPE	<input checked="" type="checkbox"/> Shelby Tube	<input type="checkbox"/> No Recovery	<input checked="" type="checkbox"/> SPT (N)	<input type="checkbox"/> Grab Sample	<input type="checkbox"/> Split-Pen	<input type="checkbox"/> Core
BACKFILL TYPE	<input checked="" type="checkbox"/> Bentonite	<input type="checkbox"/> Pea Gravel	<input checked="" type="checkbox"/> Drill Cuttings	<input type="checkbox"/> Grout	<input type="checkbox"/> Slough	<input type="checkbox"/> Sand

DEPTH (m)	UNCONFINED COMPRESSION (kPa)		SOIL SYMBOL	MUSCS	SOIL DESCRIPTION	SAMPLE TYPE	SAMPLE NO	SPT (N)	COMMENTS	DEPTH (m)
	▲	□								
0	POCKET PENETROMETER (kPa)		ASPH		ASPHALT - 114mm thick					
0	POCKET PENETROMETER (kPa)		GP		GRAVEL FILL (LIMESTONE) - and sand, trace silt, poorly graded, fine to coarse grained, damp, compact (inferred), white		1			
0.5	POCKET PENETROMETER (kPa)				TEST HOLE TERMINATED AT 0.5m BELOW EXISTING GRADE.					
0.5	POCKET PENETROMETER (kPa)				NOTES:					
0.5	POCKET PENETROMETER (kPa)				- No sloughing or seepage was observed during drilling.					
0.5	POCKET PENETROMETER (kPa)				- Test hole remained open to 0.5m with no water accumulation upon completion of drilling.					
0.5	POCKET PENETROMETER (kPa)				- Test hole was backfilled with auger cuttings, bentonite and an asphalt cold patch.					
1	POCKET PENETROMETER (kPa)									1
2	POCKET PENETROMETER (kPa)									2
3	POCKET PENETROMETER (kPa)									3
4	POCKET PENETROMETER (kPa)									4
5	POCKET PENETROMETER (kPa)									5
6	POCKET PENETROMETER (kPa)									6
7	POCKET PENETROMETER (kPa)									7
8	POCKET PENETROMETER (kPa)									8
9	POCKET PENETROMETER (kPa)									9
10	POCKET PENETROMETER (kPa)									10

WX19175 - DILLON\_GROSVENOR AVE\_2\_R1.GPJ\_20/10/13 09:37 AM (WPG - GEOTECH LOG 1)



Wood Environment & Infrastructure Solutions  
a division of Wood Canada Limited

LOGGED BY: JW	COMPLETION DEPTH: 0.5 m
REVIEWED BY: JP	COMPLETION DATE: March 10, 2020
Figure No.	Sheet 1 of 1

PROJECT: City of Winnipeg Street Investigation	DRILLER: Maple Leaf Drilling Ltd.	TEST HOLE ID: <b>GROS2-06</b>
CLIENT: Dillon Consulting	DRILL RIG: Truck Mounted B40	PROJECT No: WX19175
LOCATION: Grosvenor Avenue 2, Winnipeg, MB	DRILL METHOD: 138mm Core & 125mm SSA	ELEVATION: Not Surveyed

SAMPLE TYPE	<input checked="" type="checkbox"/> Shelby Tube	<input type="checkbox"/> No Recovery	<input checked="" type="checkbox"/> SPT (N)	<input type="checkbox"/> Grab Sample	<input type="checkbox"/> Split-Pen	<input type="checkbox"/> Core
-------------	---	--------------------------------------	---	--------------------------------------	------------------------------------	-------------------------------

BACKFILL TYPE	<input checked="" type="checkbox"/> Bentonite	<input type="checkbox"/> Pea Gravel	<input checked="" type="checkbox"/> Drill Cuttings	<input type="checkbox"/> Grout	<input type="checkbox"/> Slough	<input type="checkbox"/> Sand
---------------	---	-------------------------------------	--	--------------------------------	---------------------------------	-------------------------------

DEPTH (m)	UNCONFINED COMPRESSION (kPa)		SOIL SYMBOL	MUSCS	SOIL DESCRIPTION	SAMPLE TYPE	SAMPLE NO	SPT (N)	COMMENTS	DEPTH (m)
	▲	▲								
0	100	200	ASPH		ASPHALT - 140mm thick					0
			GM		GRAVEL FILL (LIMESTONE) - and sand, silty, poorly graded, fine to medium grained, damp, compact (inferred), white - below 0.4m, trace clay		1			
1					TEST HOLE TERMINATED AT 0.5m BELOW EXISTING GRADE.					1
2					NOTES:					2
3					- No sloughing or seepage was observed during drilling.					3
4					- Test hole remained open to 0.5m with no water accumulation upon completion of drilling.					4
5					- Test hole was backfilled with auger cuttings, bentonite and an asphalt cold patch.					5
6										6
7										7
8										8
9										9
10										10

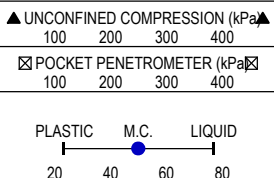

WX19175 - DILLON\_GROSVENOR AVE\_2\_R1.GPJ 20/10/13 09:37 AM (WPG - GEOTECH LOG 1)



**Wood Environment & Infrastructure Solutions**  
a division of Wood Canada Limited

LOGGED BY: JW	COMPLETION DEPTH: 0.5 m
REVIEWED BY: JP	COMPLETION DATE: March 10, 2020
Figure No.	Sheet 1 of 1

PROJECT: City of Winnipeg Street Investigation	DRILLER: Maple Leaf Drilling Ltd.	TEST HOLE ID: <b>GROS2-07</b>
CLIENT: Dillon Consulting	DRILL RIG: Truck Mounted B40	PROJECT No: WX19175
LOCATION: Grosvenor Avenue 2, Winnipeg, MB	DRILL METHOD: 138mm Core & 125mm SSA	ELEVATION: Not Surveyed

SAMPLE TYPE	<input checked="" type="checkbox"/> Shelby Tube	<input type="checkbox"/> No Recovery	<input checked="" type="checkbox"/> SPT (N)	<input type="checkbox"/> Grab Sample	<input type="checkbox"/> Split-Pen	<input type="checkbox"/> Core
BACKFILL TYPE	<input checked="" type="checkbox"/> Bentonite	<input type="checkbox"/> Pea Gravel	<input checked="" type="checkbox"/> Drill Cuttings	<input type="checkbox"/> Grout	<input type="checkbox"/> Slough	<input type="checkbox"/> Sand

DEPTH (m)	UNCONFINED COMPRESSION (kPa)		SOIL SYMBOL	MUSCS	SOIL DESCRIPTION	SAMPLE TYPE	SAMPLE NO	SPT (N)	COMMENTS	DEPTH (m)
	▲	□								
0	POCKET PENETROMETER (kPa) 100 200 300 400		ASPH		ASPHALT - 66mm thick		1			0
0	PLASTIC M.C. LIQUID 20 40 60 80		GM		GRAVEL FILL (LIMESTONE) - and sand, silty, poorly graded, fine to coarse grained, damp, compact (inferred), white					0
1					TEST HOLE TERMINATED AT 0.5m BELOW EXISTING GRADE.					1
1					NOTES:					1
1					- No sloughing or seepage was observed during drilling.					1
1					- Test hole remained open to 0.5m with no water accumulation upon completion of drilling.					1
1					- Test hole was backfilled with auger cuttings, bentonite and an asphalt cold patch.					1
2										2
3										3
4										4
5										5
6										6
7										7
8										8
9										9
10										10

WX19175 - DILLON\_GROSVENOR AVE\_2\_R1.GPJ\_20/10/13 09:37 AM (WPG - GEOTECH LOG 1)



Wood Environment & Infrastructure Solutions  
a division of Wood Canada Limited

LOGGED BY: JW	COMPLETION DEPTH: 0.5 m
REVIEWED BY: JP	COMPLETION DATE: March 10, 2020
Figure No.	Sheet 1 of 1

PROJECT: City of Winnipeg Street Investigation	DRILLER: Maple Leaf Drilling Ltd.	TEST HOLE ID: <b>GROS2-08</b>
CLIENT: Dillon Consulting	DRILL RIG: Truck Mounted B40	PROJECT No: WX19175
LOCATION: Grosvenor Avenue 2, Winnipeg, MB	DRILL METHOD: 138mm Core & 125mm SSA	ELEVATION: Not Surveyed

SAMPLE TYPE	<input checked="" type="checkbox"/> Shelby Tube	<input type="checkbox"/> No Recovery	<input checked="" type="checkbox"/> SPT (N)	<input type="checkbox"/> Grab Sample	<input type="checkbox"/> Split-Pen	<input type="checkbox"/> Core
BACKFILL TYPE	<input checked="" type="checkbox"/> Bentonite	<input type="checkbox"/> Pea Gravel	<input checked="" type="checkbox"/> Drill Cuttings	<input type="checkbox"/> Grout	<input type="checkbox"/> Slough	<input type="checkbox"/> Sand

DEPTH (m)	UNCONFINED COMPRESSION (kPa)		SOIL SYMBOL	MUSCS	SOIL DESCRIPTION	SAMPLE TYPE	SAMPLE NO	SPT (N)	COMMENTS	DEPTH (m)
	▲	□								
0	POCKET PENETROMETER (kPa) PLASTIC    M.C.    LIQUID 20    40    60    80		ASPH	CONC	GM	CH	1			0
0					ASPHALT - 75mm thick					0
0					CONCRETE SLAB - 125mm thick					0
0					GRAVEL FILL (LIMESTONE) - and sand, silty, poorly graded, fine to coarse grained, damp, compact (inferred), white					0
0					CLAY - silty, high plastic, moist, stiff, dark grey, occasional silt pockets					0
0					TEST HOLE TERMINATED AT 0.5m BELOW EXISTING GRADE.					0
0					NOTES:					0
0					- No sloughing or seepage was observed during drilling.					0
0					- Test hole remained open to 0.5m with no water accumulation upon completion of drilling.					0
0					- Test hole was backfilled with auger cuttings, bentonite and an asphalt cold patch.					0
1										1
2										2
3										3
4										4
5										5
6										6
7										7
8										8
9										9
10										10

WX19175 - DILLON\_GROSVENOR AVE\_2\_R1.GPJ\_20/10/13 09:37 AM (WPG - GEOTECH LOG 1)



Wood Environment & Infrastructure Solutions  
a division of Wood Canada Limited

LOGGED BY: JW	COMPLETION DEPTH: 0.5 m
REVIEWED BY: JP	COMPLETION DATE: March 10, 2020
Figure No.	Sheet 1 of 1



PROJECT: City of Winnipeg Street Investigation	DRILLER: Maple Leaf Drilling Ltd.	TEST HOLE ID: <b>GROS2-09</b>
CLIENT: Dillon Consulting	DRILL RIG: Truck Mounted B40	PROJECT No: WX19175
LOCATION: Grosvenor Avenue 2, Winnipeg, MB	DRILL METHOD: 138mm Core & 125mm SSA	ELEVATION: Not Surveyed

SAMPLE TYPE	<input checked="" type="checkbox"/> Shelby Tube	<input type="checkbox"/> No Recovery	<input checked="" type="checkbox"/> SPT (N)	<input type="checkbox"/> Grab Sample	<input type="checkbox"/> Split-Pen	<input type="checkbox"/> Core
-------------	---	--------------------------------------	---	--------------------------------------	------------------------------------	-------------------------------

BACKFILL TYPE	<input checked="" type="checkbox"/> Bentonite	<input type="checkbox"/> Pea Gravel	<input checked="" type="checkbox"/> Drill Cuttings	<input type="checkbox"/> Grout	<input type="checkbox"/> Slough	<input type="checkbox"/> Sand
---------------	---	-------------------------------------	--	--------------------------------	---------------------------------	-------------------------------

DEPTH (m)	UNCONFINED COMPRESSION (kPa)		SOIL SYMBOL	MUSCS	SOIL DESCRIPTION	SAMPLE TYPE	SAMPLE NO	SPT (N)	COMMENTS	DEPTH (m)
	▲	▲								
0	POCKET PENETROMETER (kPa) 100 200 300 400 PLASTIC M.C. LIQUID 20 40 60 80		ASPH GM CH		ASPHALT - 81mm thick GRAVEL FILL (LIMESTONE) - and sand, silty, poorly graded, fine to medium grained, damp, compact (inferred), white CLAY - silty, high plastic, moist, firm, dark grey, occasional silt pockets TEST HOLE TERMINATED AT 0.5m BELOW EXISTING GRADE. NOTES: - No sloughing or seepage was observed during drilling. - Test hole remained open to 0.5m with no water accumulation upon completion of drilling. - Test hole was backfilled with auger cuttings, bentonite and an asphalt cold patch.		1			0

WX19175 - DILLON\_GROSVENOR AVE\_2\_R1.GPJ 20/10/13 09:37 AM (WPG - GEOTECH LOG 1)



**Wood Environment & Infrastructure Solutions**  
a division of Wood Canada Limited

LOGGED BY: JW	COMPLETION DEPTH: 0.5 m
REVIEWED BY: JP	COMPLETION DATE: March 10, 2020
Figure No.	Sheet 1 of 1

# Appendix G

## Nathaniel Street 1

- Test Hole Location Plan
- Core Photos
- Test Hole Logs

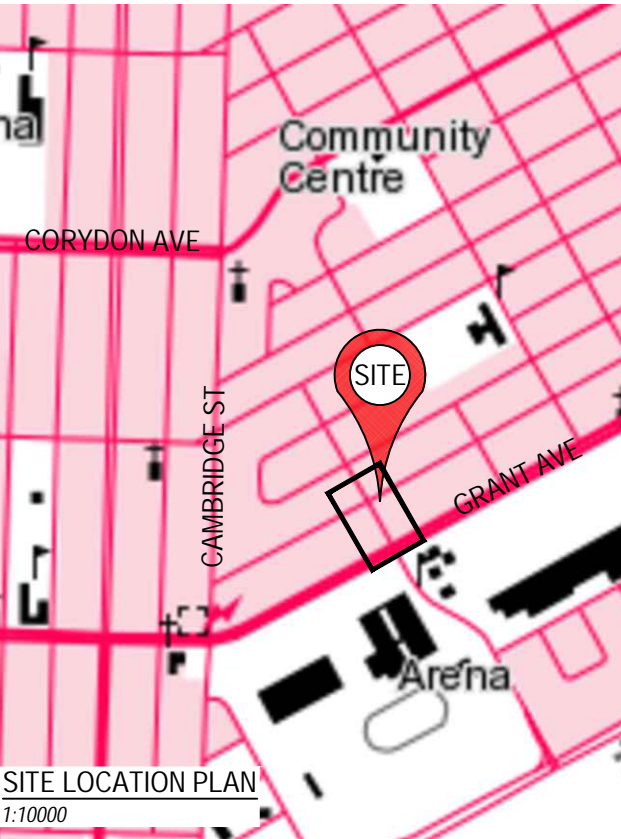
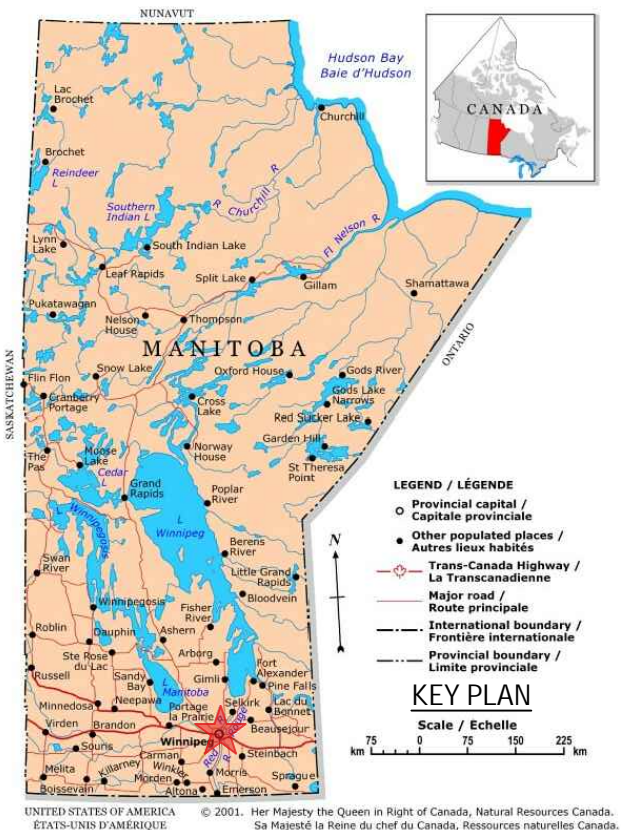

NOTES: SITE FEATURES AND LOCATIONS ARE APPROXIMATE ONLY. IMAGES FROM AUTODESK IMAGERY AND TOPO MAPS.

**LEGEND:**

TEST HOLE

REVISION	BY	DATE
----	----	----

CLIENT:

DILLON CONSULTING LTD.

**wood.**

440 DOVERCOURT DRIVE  
WINNIPEG, MANITOBA R3Y 1N4  
PHONE: 204.488.2997 FAX:204.489.8261

DWN BY: MD  
CHK'D BY: JP  
DATUM: ---  
PROJECTION: ---  
SCALE: AS SHOWN

CITY OF WINNIPEG STREET INVESTIGATION  
PROJECT 21-R-05  
WINNIPEG, MANITOBA

SITE AND TEST HOLE LOCATION PLAN -  
NATHANIEL STREET FROM GRANT AVENUE TO LORETTE AVENUE

DATE: OCTOBER 2020  
PROJECT NO: WX19175  
REV. NO.: A  
FIGURE NO: FIGURE 1



NAT1-01: Broken Concrete Core. Plan View



NAT1-02: Intact Core, Plan View



NAT1-02: Intact Core, Profile View

	<p align="center"><b>CORE PHOTOGRAPHS</b>  <b>NATHANEL STREET FROM GRANT AVENUE TO LORETTE AVENUE</b>  <b>WINNIPEG, MANITOBA</b></p>			
<p><b>Wood Environment and Infrastructure Solutions</b></p>	<p align="center"><b>DILLON CONSULTING LTD.</b></p>			
<p>Drawn: AL</p>	<p>Scale: N/A</p>	<p>Date: 09 October 2020</p>	<p>Project No.: WX19175</p>	

PROJECT: City of Winnipeg Street Investigation	DRILLER: Maple Leaf Drilling Ltd.	TEST HOLE ID: <b>NAT1-01</b>
CLIENT: Dillon Consulting	DRILL RIG: Truck Mounted B40	PROJECT No: WX19175
LOCATION: Nathaniel Street 1, Winnipeg, MB	DRILL METHOD: 138mm Core & 125mm SSA	ELEVATION: Not Surveyed

SAMPLE TYPE	<input checked="" type="checkbox"/> Shelby Tube	<input type="checkbox"/> No Recovery	<input checked="" type="checkbox"/> SPT (N)	<input type="checkbox"/> Grab Sample	<input type="checkbox"/> Split-Pen	<input type="checkbox"/> Core
BACKFILL TYPE	<input checked="" type="checkbox"/> Bentonite	<input type="checkbox"/> Pea Gravel	<input checked="" type="checkbox"/> Drill Cuttings	<input type="checkbox"/> Grout	<input type="checkbox"/> Slough	<input type="checkbox"/> Sand

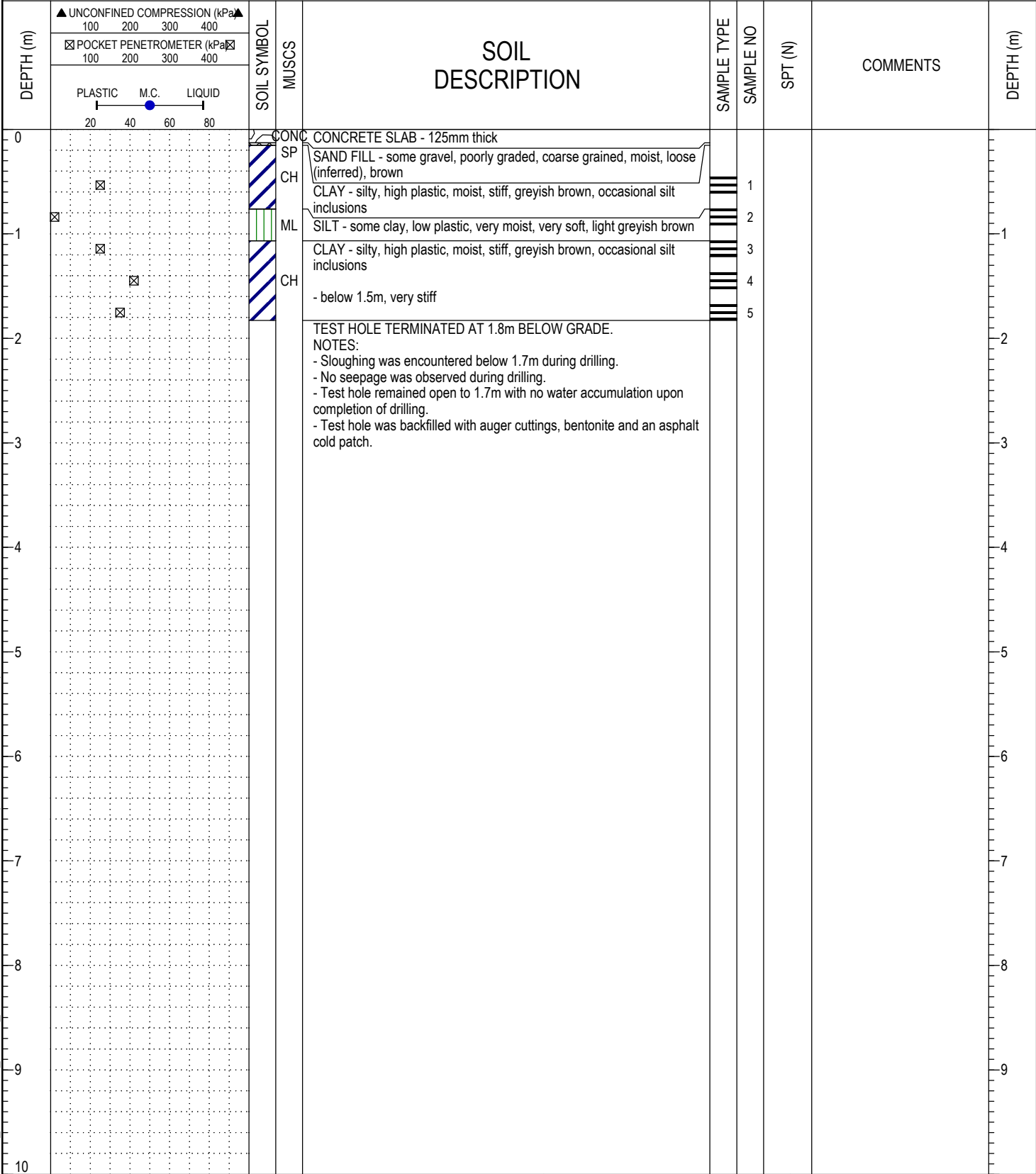

WX19175 - DILLON\_NATHANIEL\_GRANT\_LOTETTE R1.GPJ 20/10/10 08:34 AM (WPG - GEOTECH LOG 1)



**Wood Environment & Infrastructure Solutions**  
 a division of Wood Canada Limited

LOGGED BY: AL	COMPLETION DEPTH: 1.8 m
REVIEWED BY: JP	COMPLETION DATE: September 16, 2020
Figure No.	Sheet 1 of 1

PROJECT: City of Winnipeg Street Investigation	DRILLER: Maple Leaf Drilling Ltd.	TEST HOLE ID: <b>NAT1-02</b>
CLIENT: Dillon Consulting	DRILL RIG: Truck Mounted B40	PROJECT No: WX19175
LOCATION: Nathaniel Street 1, Winnipeg, MB	DRILL METHOD: 138mm Core & 125mm SSA	ELEVATION: Not Surveyed

SAMPLE TYPE	<input checked="" type="checkbox"/> Shelby Tube	<input type="checkbox"/> No Recovery	<input checked="" type="checkbox"/> SPT (N)	<input type="checkbox"/> Grab Sample	<input type="checkbox"/> Split-Pen	<input type="checkbox"/> Core
BACKFILL TYPE	<input checked="" type="checkbox"/> Bentonite	<input type="checkbox"/> Pea Gravel	<input checked="" type="checkbox"/> Drill Cuttings	<input type="checkbox"/> Grout	<input type="checkbox"/> Slough	<input type="checkbox"/> Sand

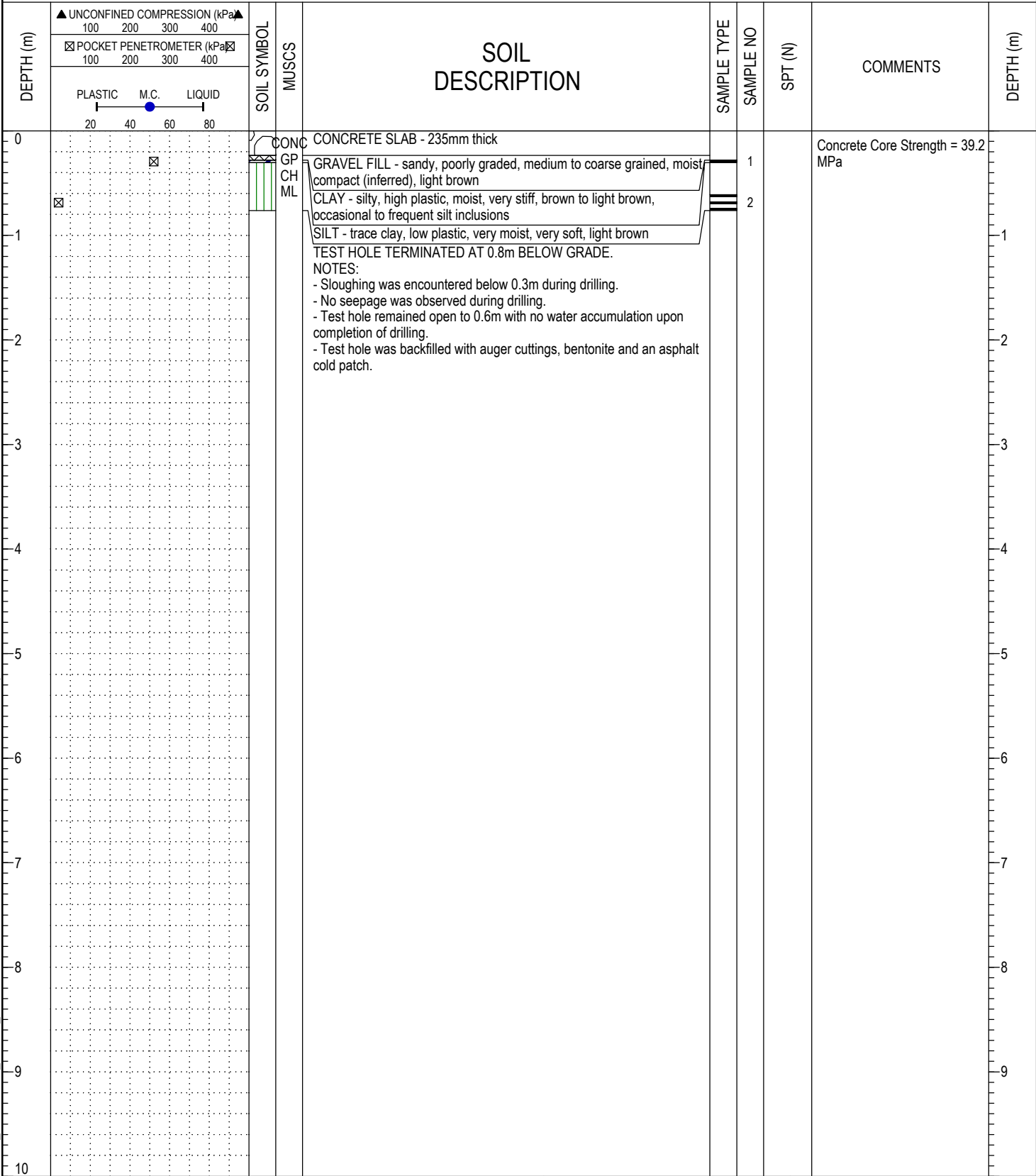

WX19175 - DILLON\_NATHANIEL\_GRANT\_LOTETTE R1.GPJ 20/10/10 08:34 AM (WPG - GEOTECH LOG 1)



**Wood Environment & Infrastructure Solutions**  
 a division of Wood Canada Limited

LOGGED BY: AL	COMPLETION DEPTH: 0.8 m
REVIEWED BY: JP	COMPLETION DATE: September 16, 2020
Figure No.	Sheet 1 of 1

# Appendix H

## Nathaniel Street 2

- Test Hole Location Plan
- Core Photos
- Test Hole Logs

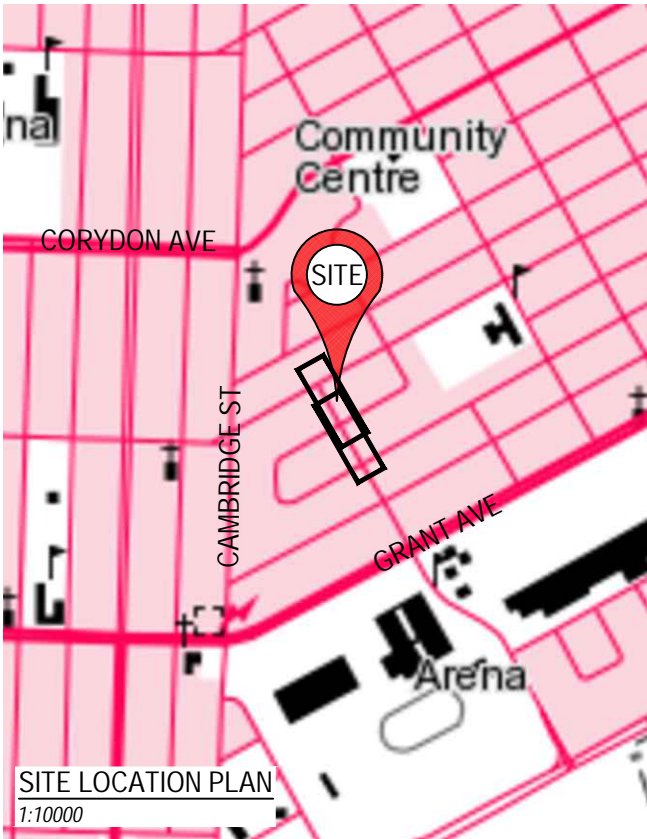
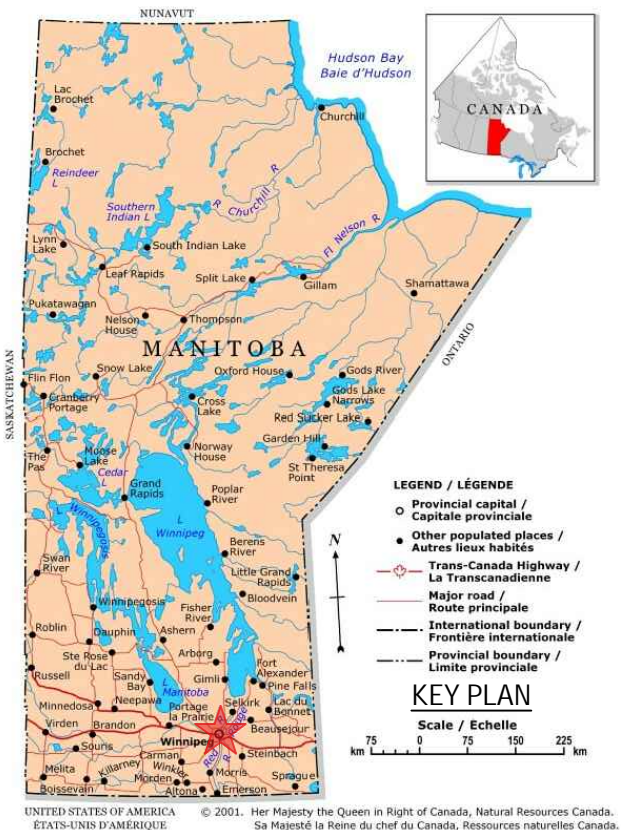

NOTES: SITE FEATURES AND LOCATIONS ARE APPROXIMATE ONLY. IMAGES FROM AUTODESK IMAGERY AND TOPO MAPS.

**LEGEND:**  
TEST HOLE

REVISION	BY	DATE
----	----	----

CLIENT:  
  
DILLON CONSULTING LTD.

**wood.**  
440 DOVERCOURT DRIVE  
WINNIPEG, MANITOBA R3Y 1N4  
PHONE: 204.488.2997 FAX:204.489.8261

DWN BY: MD  
CHK'D BY: JP  
DATUM: ---  
PROJECTION: ---  
SCALE: AS SHOWN

CITY OF WINNIPEG STREET INVESTIGATION  
PROJECT 21-R-05  
WINNIPEG, MANITOBA

SITE AND TEST HOLE LOCATION PLAN -  
NATHANIEL STREET FROM DUDLEY AVENUE TO FLEET AVENUE

DATE: OCTOBER 2020  
PROJECT NO: WX19175  
REV. NO.: A  
FIGURE NO: FIGURE 1





NAT2-01: Intact Core, Plan View



NAT2-01: Intact Core, Profile View



NAT2-02: Intact Core, Plan View



NAT2-02: Intact Core, Profile View

	<p align="center"><b>CORE PHOTOGRAPHS</b>  <b>NATHANEL STREET FROM FLEET AVENUE TO DUDLEY AVENUE</b>  <b>WINNIPEG, MANITOBA</b></p>			
<p><b>Wood Environment and Infrastructure Solutions</b></p>	<p align="center"><b>DILLON CONSULTING LTD.</b></p>			
<p>Drawn: AL</p>	<p>Scale: N/A</p>	<p>Date: 09 October 2020</p>	<p>Project No.: WX19175</p>	



NAT2-03: Intact Core, Plan View



NAT2-03: Intact Core, Profile View

	<p align="center"><b>CORE PHOTOGRAPHS</b>  <b>NATHANEL STREET FROM FLEET AVENUE TO DUDLEY AVENUE</b>  <b>WINNIPEG, MANITOBA</b></p>		
<p><b>Wood Environment and Infrastructure Solutions</b></p>	<p align="center"><b>DILLON CONSULTING LTD.</b></p>		
<p>Drawn: AL</p>	<p>Scale: N/A</p>	<p>Date: 09 October 2020</p>	<p>Project No.: WX19175</p>

PROJECT: City of Winnipeg Street Investigation	DRILLER: Maple Leaf Drilling Ltd.	TEST HOLE ID: <b>NAT2-01</b>
CLIENT: Dillon Consulting	DRILL RIG: Truck Mounted B40	PROJECT No: WX19175
LOCATION: Nathaniel Street 2, Winnipeg, MB	DRILL METHOD: 138mm Core & 125mm SSA	ELEVATION: Not Surveyed

SAMPLE TYPE	<input checked="" type="checkbox"/> Shelby Tube	<input type="checkbox"/> No Recovery	<input checked="" type="checkbox"/> SPT (N)	<input type="checkbox"/> Grab Sample	<input type="checkbox"/> Split-Pen	<input type="checkbox"/> Core
BACKFILL TYPE	<input checked="" type="checkbox"/> Bentonite	<input type="checkbox"/> Pea Gravel	<input checked="" type="checkbox"/> Drill Cuttings	<input type="checkbox"/> Grout	<input type="checkbox"/> Slough	<input type="checkbox"/> Sand

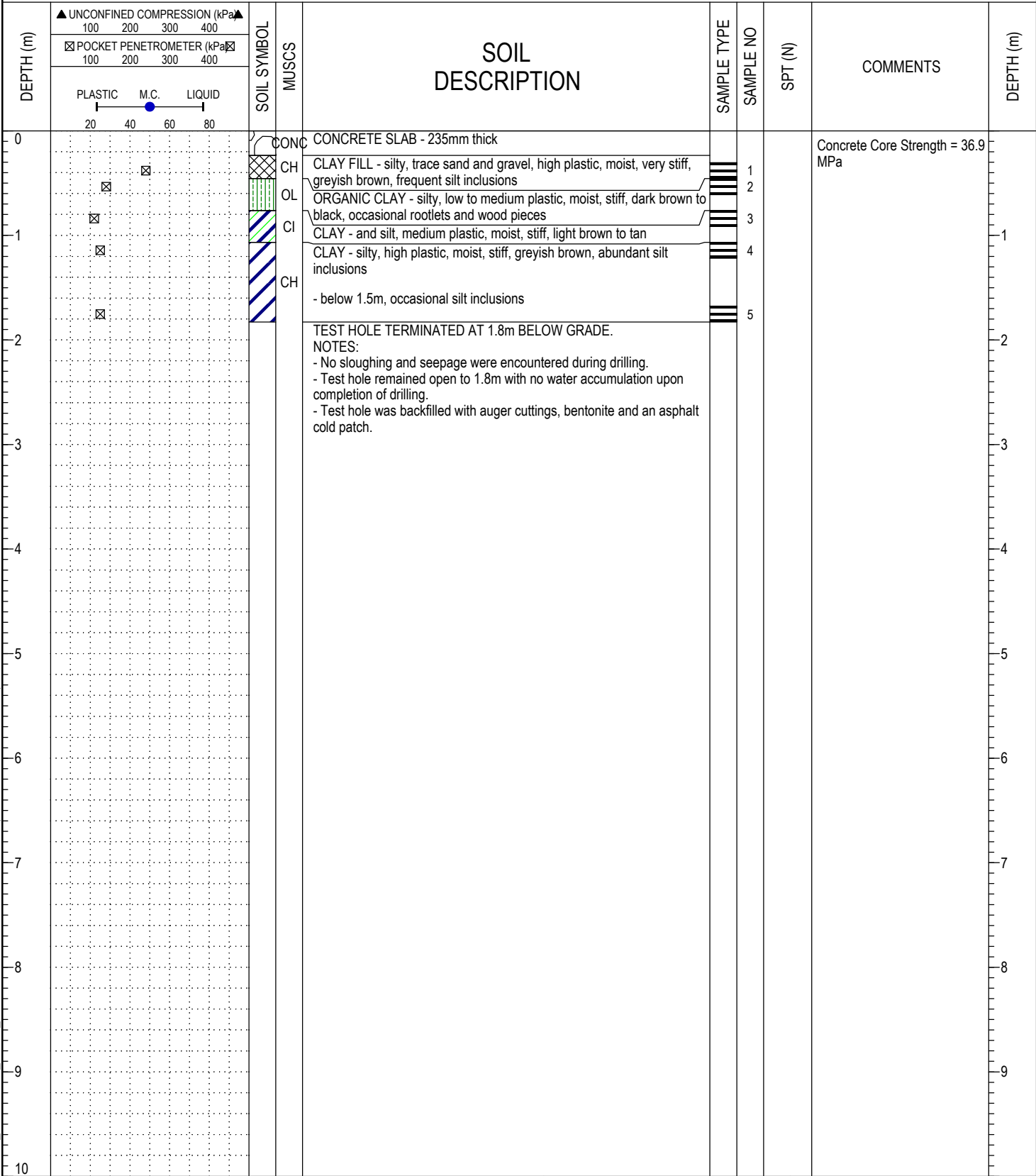

WX19175 - DILLON\_NATHANIEL\_FLEET\_DUDLEY.R1.GPJ\_20/10/10 08:37 AM (WPG - GEOTECH LOG 1)



**Wood Environment & Infrastructure Solutions**  
 a division of Wood Canada Limited

LOGGED BY: AL	COMPLETION DEPTH: 1.8 m
REVIEWED BY: JP	COMPLETION DATE: September 16, 2020
Figure No.	Sheet 1 of 1

PROJECT: City of Winnipeg Street Investigation	DRILLER: Maple Leaf Drilling Ltd.	TEST HOLE ID: <b>NAT2-02</b>
CLIENT: Dillon Consulting	DRILL RIG: Truck Mounted B40	PROJECT No: WX19175
LOCATION: Nathaniel Street 2, Winnipeg, MB	DRILL METHOD: 138mm Core & 125mm SSA	ELEVATION: Not Surveyed

SAMPLE TYPE	<input checked="" type="checkbox"/> Shelby Tube	<input type="checkbox"/> No Recovery	<input checked="" type="checkbox"/> SPT (N)	<input type="checkbox"/> Grab Sample	<input type="checkbox"/> Split-Pen	<input type="checkbox"/> Core
BACKFILL TYPE	<input checked="" type="checkbox"/> Bentonite	<input type="checkbox"/> Pea Gravel	<input checked="" type="checkbox"/> Drill Cuttings	<input type="checkbox"/> Grout	<input type="checkbox"/> Slough	<input type="checkbox"/> Sand

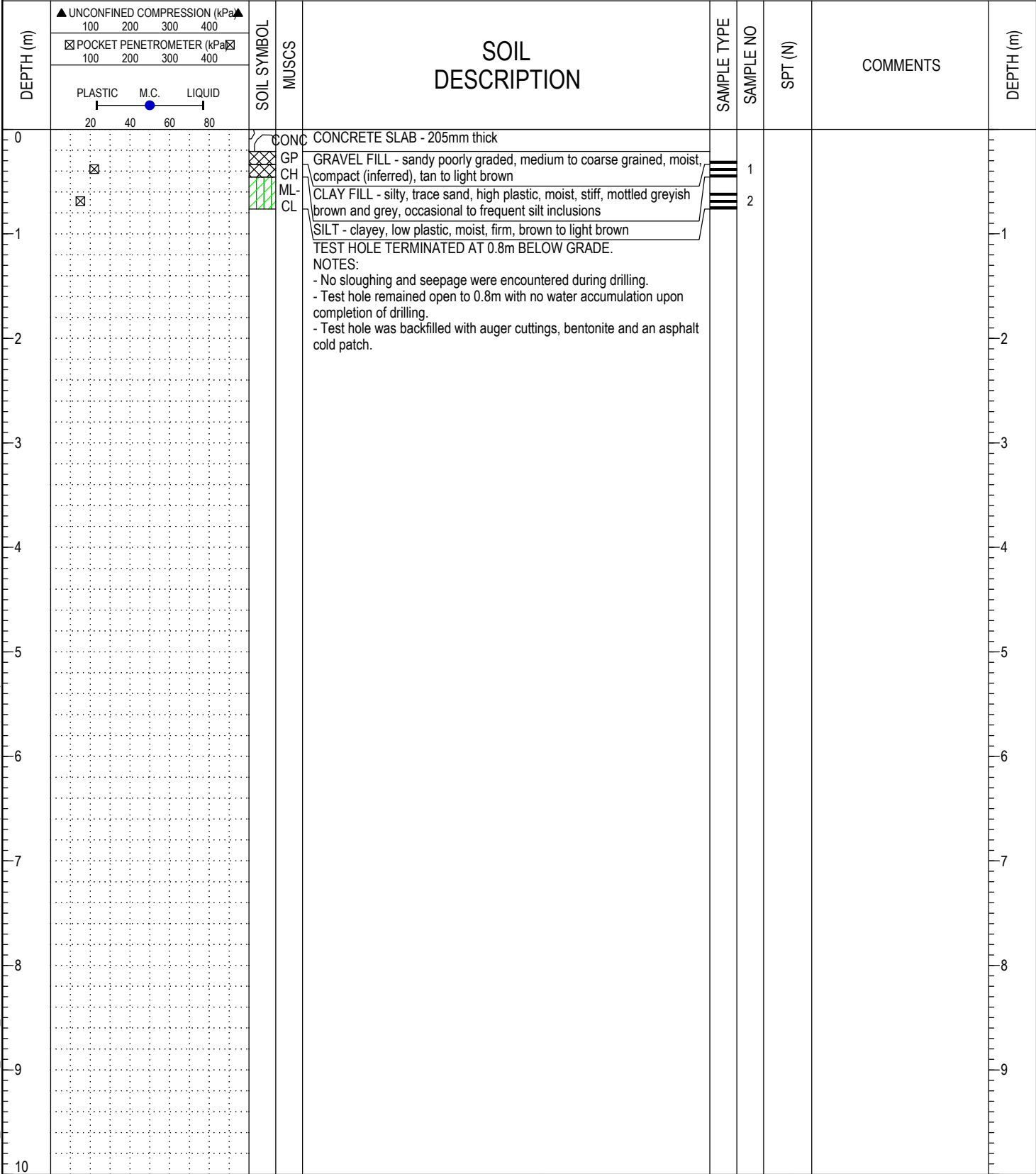

WX19175 - DILLON\_NATHANIEL\_FLEET\_DUDLEY.R1.GPJ\_20/10/10 08:37 AM (WPG - GEOTECH LOG 1)



**Wood Environment & Infrastructure Solutions**  
 a division of Wood Canada Limited

LOGGED BY: AL	COMPLETION DEPTH: 0.8 m
REVIEWED BY: JP	COMPLETION DATE: September 16, 2020
Figure No.	Sheet 1 of 1

PROJECT: City of Winnipeg Street Investigation	DRILLER: Maple Leaf Drilling Ltd.	TEST HOLE ID: NAT2-03
CLIENT: Dillon Consulting	DRILL RIG: Truck Mounted B40	PROJECT No: WX19175
LOCATION: Nathaniel Street 2, Winnipeg, MB	DRILL METHOD: 138mm Core & 125mm SSA	ELEVATION: Not Surveyed

SAMPLE TYPE	<input checked="" type="checkbox"/> Shelby Tube	<input type="checkbox"/> No Recovery	<input checked="" type="checkbox"/> SPT (N)	<input type="checkbox"/> Grab Sample	<input type="checkbox"/> Split-Pen	<input type="checkbox"/> Core
BACKFILL TYPE	<input checked="" type="checkbox"/> Bentonite	<input type="checkbox"/> Pea Gravel	<input checked="" type="checkbox"/> Drill Cuttings	<input type="checkbox"/> Grout	<input type="checkbox"/> Slough	<input type="checkbox"/> Sand

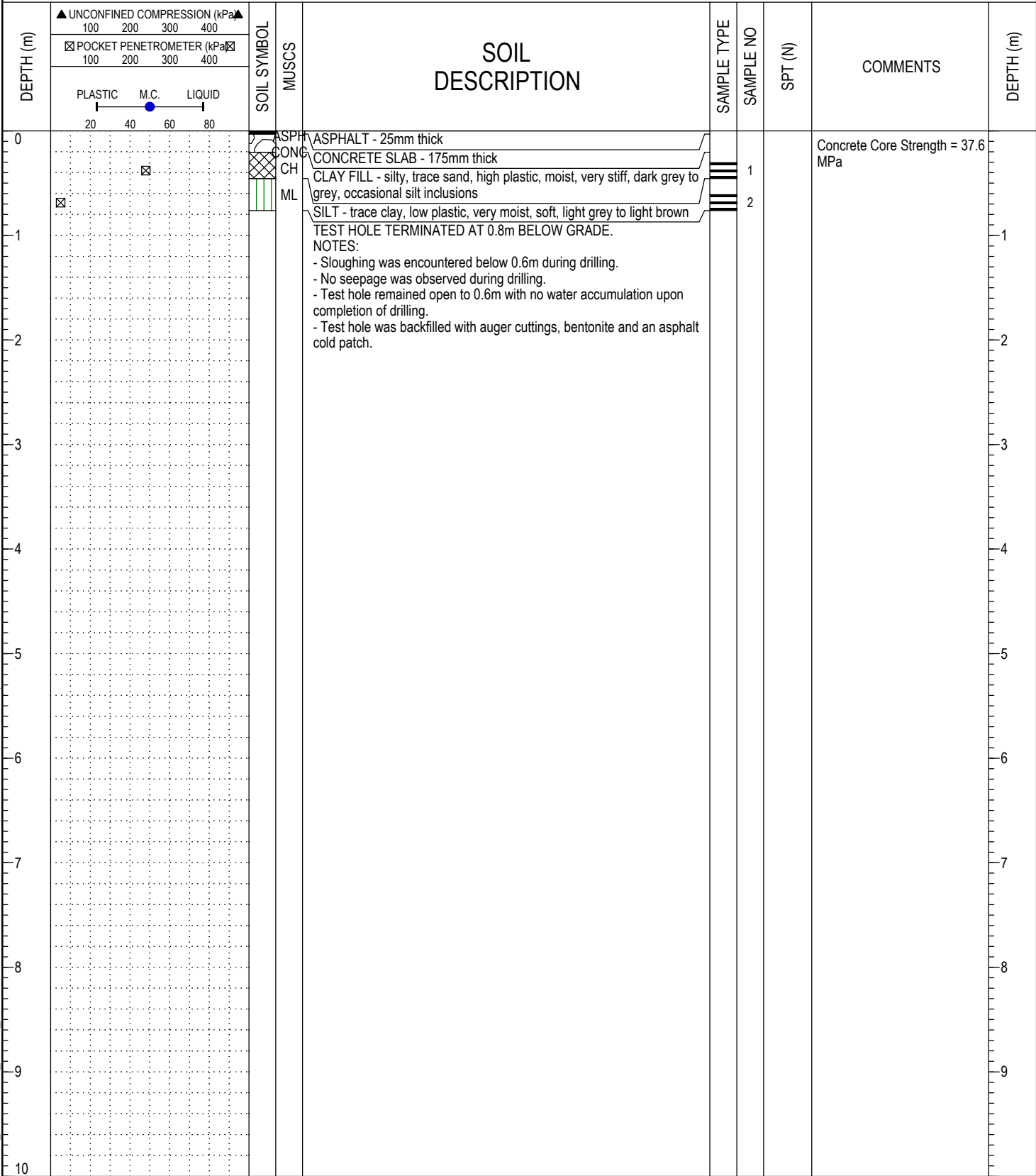

WX19175 - DILLON\_NATHANIEL\_FLEET\_DUDLEY.R1.GPJ\_20/10/10 08:37 AM (WPG - GEOTECH LOG 1)



**Wood Environment & Infrastructure Solutions**  
 a division of Wood Canada Limited

LOGGED BY: AL	COMPLETION DEPTH: 0.8 m
REVIEWED BY: JP	COMPLETION DATE: September 16, 2020
Figure No.	Sheet 1 of 1

# Appendix I

## Syracuse Crescent

- Test Hole Location Plan
- Core Photos
- Test Hole Logs

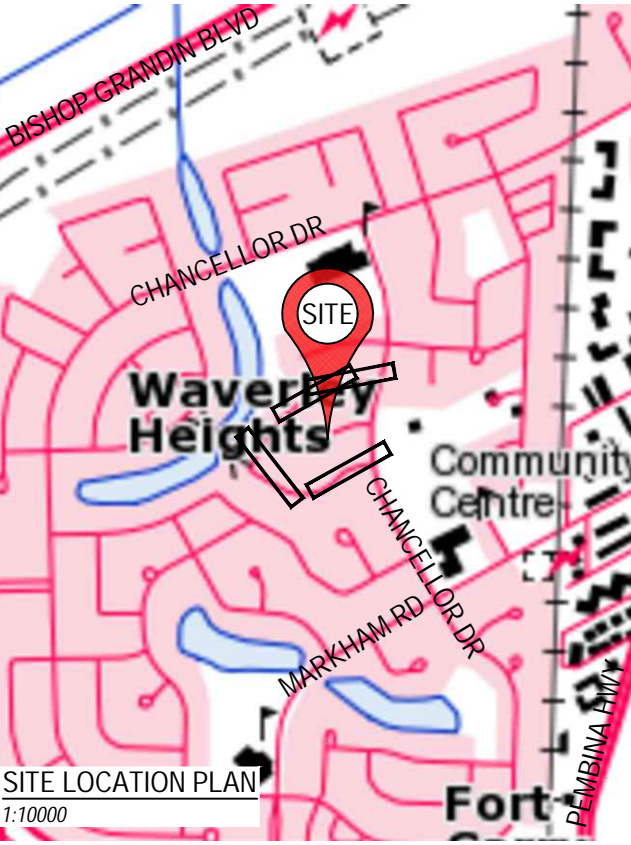
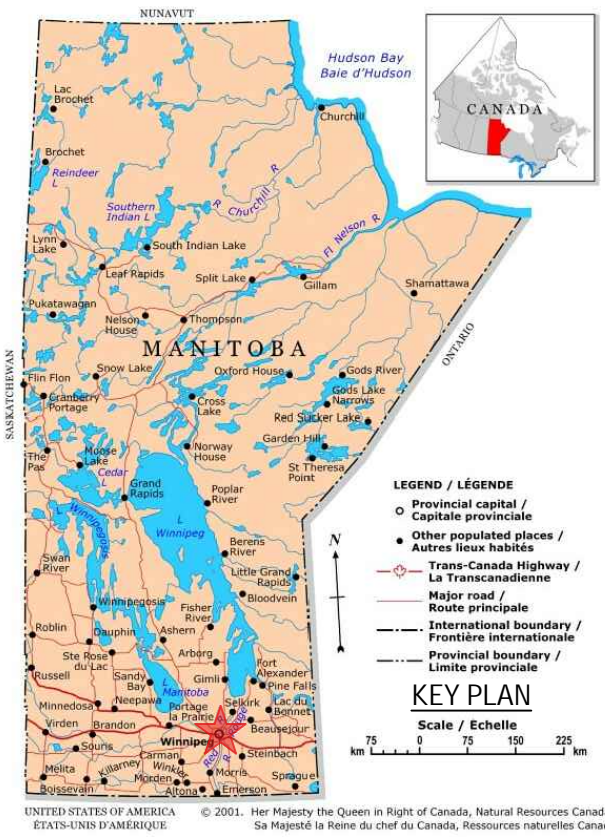

NOTES: SITE FEATURES AND LOCATIONS ARE APPROXIMATE ONLY. IMAGES FROM AUTODESK IMAGERY AND TOPO MAPS.

<b>LEGEND:</b> TEST HOLE	REVISION	BY	DATE	CLIENT:	 440 DOVERCOURT DRIVE WINNIPEG, MANITOBA R3Y 1N4 PHONE: 204.488.2997 FAX:204.489.8261	DWN BY:	CITY OF WINNIPEG STREET INVESTIGATION PROJECT 21-R-05 WINNIPEG, MANITOBA	DATE:
	----	----	----			OCTOBER 2020		
						PROJECT NO:		
						WX19175		
						REV. NO.:		
			A	FIGURE NO:			FIGURE 1	
						AS SHOWN	SITE AND TEST HOLE LOCATION PLAN - SYRACUSE CRESCENT/CHANCELLOR DRIVE	



SYR-01: Broken Half Asphalt & Concrete Layer, Plan View



SYR-02: Asphalt Layer, Plan View



SYR-02: Asphalt Layer, Profile View

	<p><b>CORE PHOTOGRAPHS</b>  <b>SYARCUSE CRESCENT FROM CHANCELLOR DRIVE TO</b>  <b>CHANCELLOR DRIVE</b>  <b>WINNIPEG, MANITOBA</b></p>			
<p><b>Wood Environment and Infrastructure Solutions</b></p>	<p><b>DILLON CONSULTING LTD.</b></p>			
<p>Drawn: AL</p>	<p>Scale: N/A</p>	<p>Date: 09 October 2020</p>	<p>Project No.: WX19175</p>	





SYR-03: Intact Core. Plan View



SYR-03: Intact Core. Profile View



SYR-04: Intact Core, Plan View



SYR-04: Intact Core, Profile View



SYR-05: Intact Core, Plan View



SYR-05: Intact Core, Profile View



SYR-06: Asphalt Layer, Plan View



SYR-06: Asphalt Layer, Profile View



SYR-06: Broken Concrete Layer, Plan View



SYR-06: Broken Concrete Layer, Profile View

	<p align="center"><b>CORE PHOTOGRAPHS SYARCUSE CRESCENT FROM CHANCELLOR DRIVE TO CHANCELLOR DRIVE WINNIPEG, MANITOBA</b></p>		
<p><b>Wood Environment and Infrastructure Solutions</b></p>	<p align="center"><b>DILLON CONSULTING LTD.</b></p>		
<p>Drawn: AL</p>	<p>Scale: N/A</p>	<p>Date: 09 October 2020</p>	<p>Project No.: WX19175</p>

PROJECT: City of Winnipeg Street Investigation	DRILLER: Maple Leaf Drilling Ltd.	TEST HOLE ID: <b>SYR-01</b>
CLIENT: Dillon Consulting	DRILL RIG: Truck Mounted B40	PROJECT No: WX19175
LOCATION: Syracuse Crescent, Winnipeg, MB	DRILL METHOD: 138mm core & 125mm SSA	ELEVATION: Not Surveyed

SAMPLE TYPE	<input checked="" type="checkbox"/> Shelby Tube	<input type="checkbox"/> No Recovery	<input checked="" type="checkbox"/> SPT (N)	<input type="checkbox"/> Grab Sample	<input type="checkbox"/> Split-Pen	<input type="checkbox"/> Core
BACKFILL TYPE	<input checked="" type="checkbox"/> Bentonite	<input type="checkbox"/> Pea Gravel	<input checked="" type="checkbox"/> Drill Cuttings	<input type="checkbox"/> Grout	<input type="checkbox"/> Slough	<input type="checkbox"/> Sand

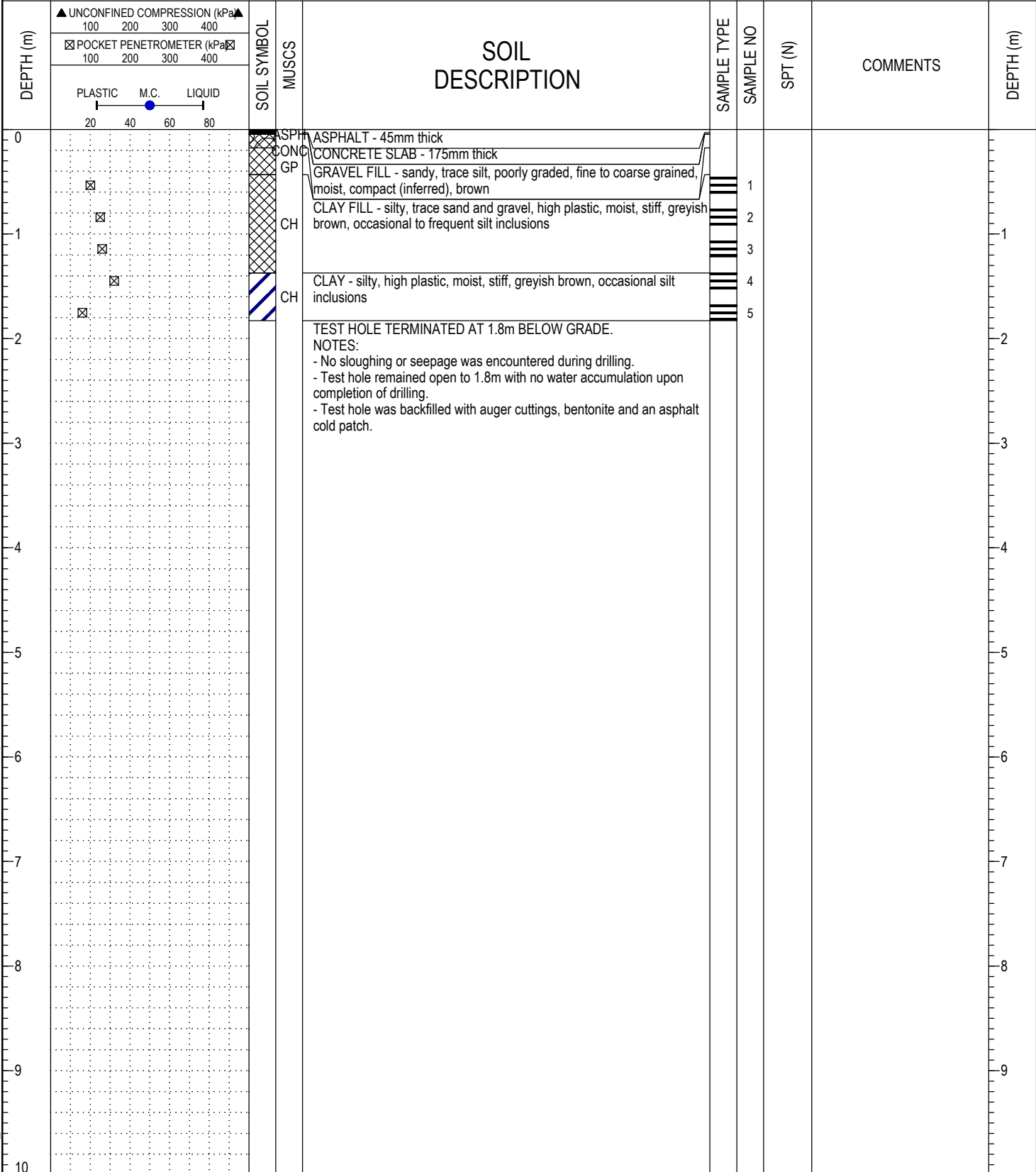

WX19175 - DILLON\_SYRACUSE CRES Rt.GPJ 20/10/09 02:12 PM (MPG - GEOTECH LOG 1)



**Wood Environment & Infrastructure Solutions**  
 a division of Wood Canada Limited

LOGGED BY: AL	COMPLETION DEPTH: 1.8 m
REVIEWED BY: JP	COMPLETION DATE: September 17, 2020
Figure No.	Sheet 1 of 1

PROJECT: City of Winnipeg Street Investigation	DRILLER: Maple Leaf Drilling Ltd.	TEST HOLE ID: <b>SYR-02</b>
CLIENT: Dillon Consulting	DRILL RIG: Truck Mounted B40	PROJECT No: WX19175
LOCATION: Syracuse Crescent, Winnipeg, MB	DRILL METHOD: 138mm core & 125mm SSA	ELEVATION: Not Surveyed

SAMPLE TYPE	<input checked="" type="checkbox"/> Shelby Tube	<input type="checkbox"/> No Recovery	<input checked="" type="checkbox"/> SPT (N)	<input type="checkbox"/> Grab Sample	<input type="checkbox"/> Split-Pen	<input type="checkbox"/> Core
BACKFILL TYPE	<input checked="" type="checkbox"/> Bentonite	<input type="checkbox"/> Pea Gravel	<input checked="" type="checkbox"/> Drill Cuttings	<input type="checkbox"/> Grout	<input type="checkbox"/> Slough	<input type="checkbox"/> Sand

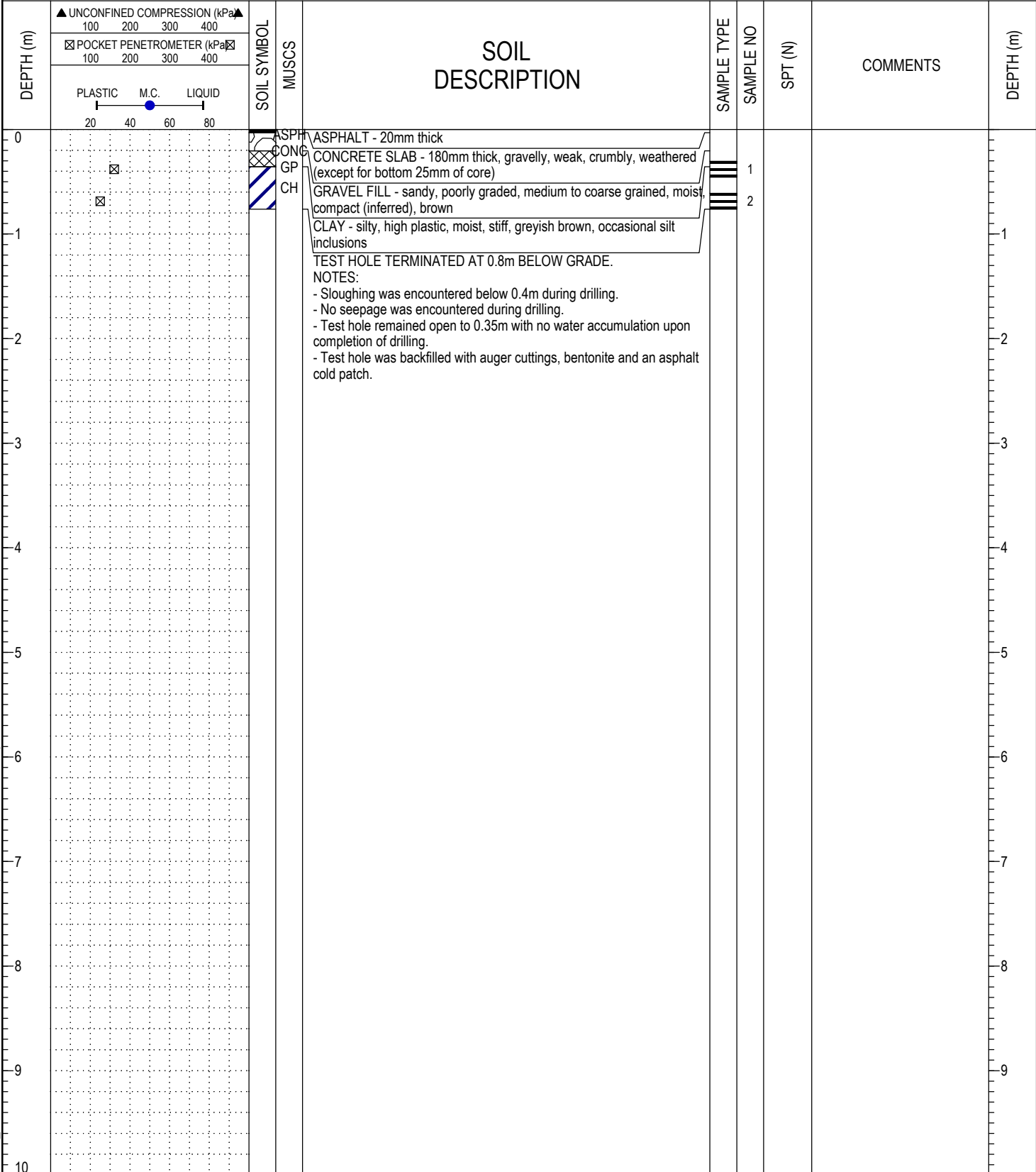

WX19175 - DILLON, SYRACUSE CRES RT.GPJ 20/10/09 02:12 PM (MPG - GEOTECH LOG 1)



**Wood Environment & Infrastructure Solutions**  
a division of Wood Canada Limited

LOGGED BY: AL	COMPLETION DEPTH: 0.8 m
REVIEWED BY: JP	COMPLETION DATE: September 17, 2020
Figure No.	Sheet 1 of 1

PROJECT: City of Winnipeg Street Investigation	DRILLER: Maple Leaf Drilling Ltd.	TEST HOLE ID: <b>SYR-03</b>
CLIENT: Dillon Consulting	DRILL RIG: Truck Mounted B40	PROJECT No: WX19175
LOCATION: Syracuse Crescent, Winnipeg, MB	DRILL METHOD: 138mm core & 125mm SSA	ELEVATION: Not Surveyed

SAMPLE TYPE	<input checked="" type="checkbox"/> Shelby Tube	<input type="checkbox"/> No Recovery	<input checked="" type="checkbox"/> SPT (N)	<input type="checkbox"/> Grab Sample	<input type="checkbox"/> Split-Pen	<input type="checkbox"/> Core
-------------	---	--------------------------------------	---	--------------------------------------	------------------------------------	-------------------------------

BACKFILL TYPE	<input checked="" type="checkbox"/> Bentonite	<input type="checkbox"/> Pea Gravel	<input checked="" type="checkbox"/> Drill Cuttings	<input type="checkbox"/> Grout	<input type="checkbox"/> Slough	<input type="checkbox"/> Sand
---------------	---	-------------------------------------	--	--------------------------------	---------------------------------	-------------------------------

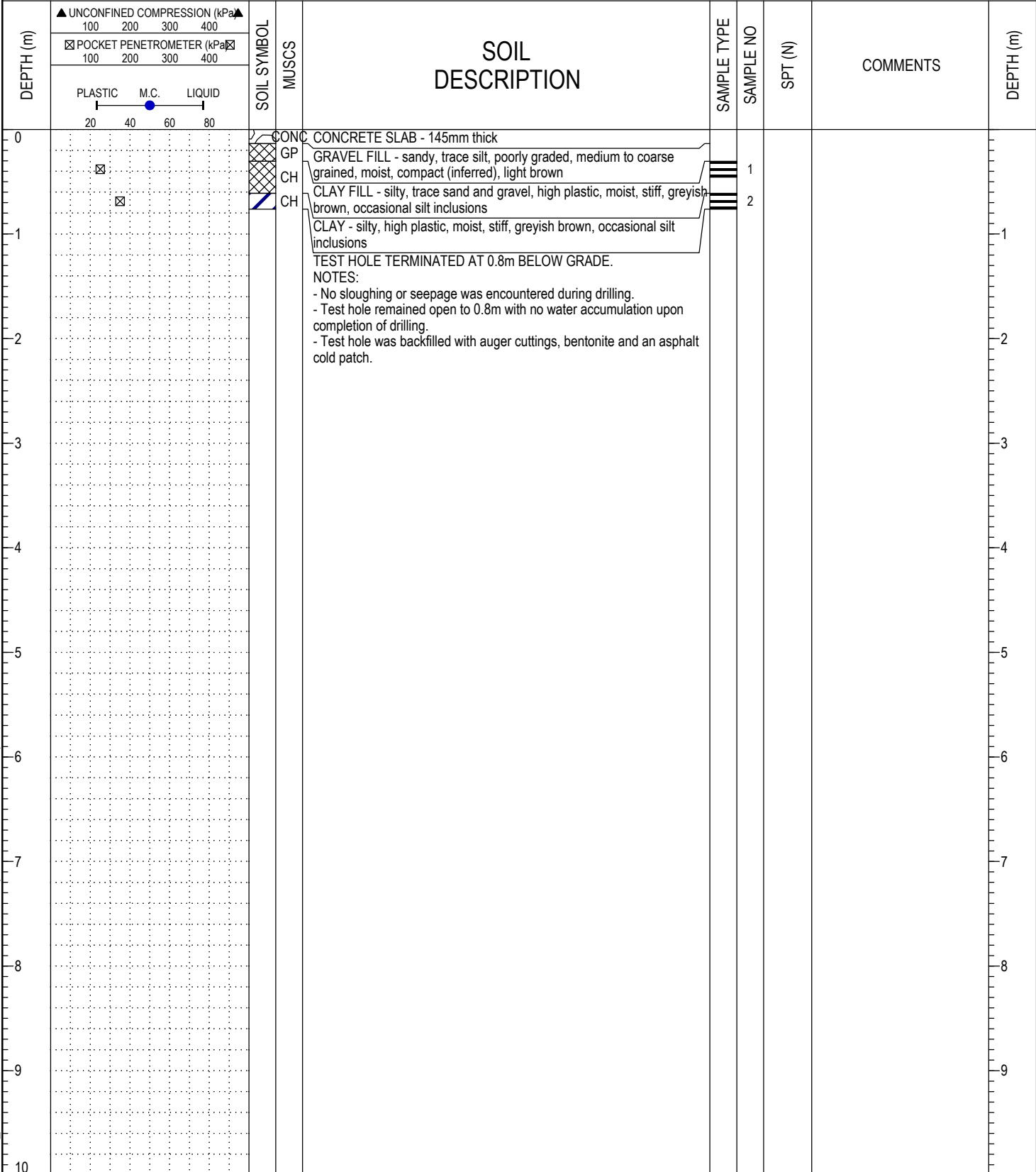

WX19175 - DILLON, SYRACUSE CRES RT.GPJ 20/10/09 02:12 PM (MPG - GEOTECH LOG 1)



**Wood Environment & Infrastructure Solutions**  
 a division of Wood Canada Limited

LOGGED BY: AL	COMPLETION DEPTH: 0.8 m
REVIEWED BY: JP	COMPLETION DATE: September 17, 2020
Figure No.	Sheet 1 of 1

PROJECT: City of Winnipeg Street Investigation	DRILLER: Maple Leaf Drilling Ltd.	TEST HOLE ID: <b>SYR-04</b>
CLIENT: Dillon Consulting	DRILL RIG: Truck Mounted B40	PROJECT No: WX19175
LOCATION: Syracuse Crescent, Winnipeg, MB	DRILL METHOD: 138mm core & 125mm SSA	ELEVATION: Not Surveyed

SAMPLE TYPE	<input checked="" type="checkbox"/> Shelby Tube	<input type="checkbox"/> No Recovery	<input checked="" type="checkbox"/> SPT (N)	<input type="checkbox"/> Grab Sample	<input type="checkbox"/> Split-Pen	<input type="checkbox"/> Core
BACKFILL TYPE	<input checked="" type="checkbox"/> Bentonite	<input type="checkbox"/> Pea Gravel	<input checked="" type="checkbox"/> Drill Cuttings	<input type="checkbox"/> Grout	<input type="checkbox"/> Slough	<input type="checkbox"/> Sand

DEPTH (m)	UNCONFINED COMPRESSION (kPa)		SOIL SYMBOL	SOIL DESCRIPTION	SAMPLE TYPE	SAMPLE NO	SPT (N)	COMMENTS	DEPTH (m)
	100	200							
	POCKET PENETROMETER (kPa)								
	100	200	300	400					
	PLASTIC		M.C.	LIQUID					
	20	40	60	80					
0				CONC				CONCRETE SLAB - 125mm thick	
0.1				CH	1			CLAY - silty, high plastic, moist, very stiff, grey to dark grey, occasional silt inclusions and rootlets	
0.2					2				
0.8								TEST HOLE TERMINATED AT 0.8m BELOW GRADE.	
1.0								NOTES: - No sloughing or seepage was encountered during drilling. - Test hole remained open to 0.8m with no water accumulation upon completion of drilling. - Test hole was backfilled with auger cuttings, bentonite and an asphalt cold patch.	
10									

WX19175 - DILLON\_SYRACUSE CRES Rt.GPJ 20/10/09 02:12 PM (WPG - GEOTECH LOG 1)



**Wood Environment & Infrastructure Solutions**  
a division of Wood Canada Limited

LOGGED BY: AL	COMPLETION DEPTH: 0.8 m
REVIEWED BY: JP	COMPLETION DATE: September 17, 2020
Figure No.	Sheet 1 of 1

PROJECT: City of Winnipeg Street Investigation	DRILLER: Maple Leaf Drilling Ltd.	TEST HOLE ID: <b>SYR-05</b>
CLIENT: Dillon Consulting	DRILL RIG: Truck Mounted B40	PROJECT No: WX19175
LOCATION: Syracuse Crescent, Winnipeg, MB	DRILL METHOD: 138mm core & 125mm SSA	ELEVATION: Not Surveyed

SAMPLE TYPE	<input checked="" type="checkbox"/> Shelby Tube	<input type="checkbox"/> No Recovery	<input checked="" type="checkbox"/> SPT (N)	<input type="checkbox"/> Grab Sample	<input type="checkbox"/> Split-Pen	<input type="checkbox"/> Core
BACKFILL TYPE	<input checked="" type="checkbox"/> Bentonite	<input type="checkbox"/> Pea Gravel	<input checked="" type="checkbox"/> Drill Cuttings	<input type="checkbox"/> Grout	<input type="checkbox"/> Slough	<input type="checkbox"/> Sand

DEPTH (m)	UNCONFINED COMPRESSION (kPa)		SOIL SYMBOL	MUSCS	SOIL DESCRIPTION	SAMPLE TYPE	SAMPLE NO	SPT (N)	COMMENTS	DEPTH (m)
	▲	▲								
0	POCKET PENETROMETER (kPa) 100 200 300 400 PLASTIC M.C. LIQUID 20 40 60 80				CONCRETE SLAB - 95mm thick GRAVEL FILL - sandy, poorly graded, moist, compact (inferred), brown CLAY - silty, trace sand, high plastic, moist, firm, greyish brown, occasional silt inclusions and roots					
0.8					TEST HOLE TERMINATED AT 0.8m BELOW GRADE. NOTES: - No sloughing or seepage was encountered during drilling. - Test hole remained open to 0.8m with no water accumulation upon completion of drilling. - Test hole was backfilled with auger cuttings, bentonite and an asphalt cold patch.					

WX19175 - DILLON\_SYRACUSE\_CRES Rt.GPJ 20/10/09 02:12 PM (MPG - GEOTECH LOG 1)



Wood Environment & Infrastructure Solutions  
a division of Wood Canada Limited

LOGGED BY: AL	COMPLETION DEPTH: 0.8 m
REVIEWED BY: JP	COMPLETION DATE: September 18, 2020
Figure No.	Sheet 1 of 1



PROJECT: City of Winnipeg Street Investigation	DRILLER: Maple Leaf Drilling Ltd.	TEST HOLE ID: <b>SYR-06</b>
CLIENT: Dillon Consulting	DRILL RIG: Truck Mounted B40	PROJECT No: WX19175
LOCATION: Syracuse Crescent, Winnipeg, MB	DRILL METHOD: 138mm core & 125mm SSA	ELEVATION: Not Surveyed

SAMPLE TYPE	<input checked="" type="checkbox"/> Shelby Tube	<input type="checkbox"/> No Recovery	<input checked="" type="checkbox"/> SPT (N)	<input type="checkbox"/> Grab Sample	<input type="checkbox"/> Split-Pen	<input type="checkbox"/> Core
BACKFILL TYPE	<input checked="" type="checkbox"/> Bentonite	<input type="checkbox"/> Pea Gravel	<input checked="" type="checkbox"/> Drill Cuttings	<input type="checkbox"/> Grout	<input type="checkbox"/> Slough	<input type="checkbox"/> Sand

DEPTH (m)	UNCONFINED COMPRESSION (kPa)		SOIL SYMBOL	MUSCS	SOIL DESCRIPTION	SAMPLE TYPE	SAMPLE NO	SPT (N)	COMMENTS	DEPTH (m)
	▲	▲								
0	100	200	ASPH		ASPHALT - 20mm thick					0
			GP		GRAVEL FILL - sandy, poorly graded, moist, compact (inferred), brown	█	1			
			CONC		CONCRETE SLAB - 150mm thick, weak, crumbly	█				
			CH							
			ML		CLAY - silty, high plastic, moist, firm, greyish brown, occasional silt inclusions	█	2			
			CL		SILT - and clay, low plastic, moist, soft, grey					
1					TEST HOLE TERMINATED AT 0.8m BELOW GRADE.					1
2					NOTES:					2
3					- No sloughing was encountered during drilling.					3
4					- Seepage was observed during coring of pavement.					4
5					- Test hole remained open to 0.8m and water level was measured at 0.6m below grade upon completion of drilling.					5
6					- Test hole was backfilled with auger cuttings, bentonite and an asphalt cold patch.					6
7										7
8										8
9										9
10										10

WX19175 - DILLON\_SYRACUSE CRES Rt.GPJ 20/10/09 02:12 PM (MPG - GEOTECH LOG 1)



**Wood Environment & Infrastructure Solutions**  
a division of Wood Canada Limited

LOGGED BY: AL	COMPLETION DEPTH: 0.8 m
REVIEWED BY: JP	COMPLETION DATE: September 18, 2020
Figure No.	Sheet 1 of 1

# California Bearing Ratio

## ASTM D1883-16, Soaking Method



Wood Environment & Infrastructure Solutions  
a Division of Wood Canada Limited

Type of Preparation	Standard ASTM D698	Sample Preparation	Soaked
Maximum Dry Density	1425 kg/m <sup>3</sup>	Soaking time	96 hrs
Optimum Moisture Content	28.4 %	Top 1 Inch Soaked Moisture	38.2 %
Compacted Dry Density	1429 kg/m <sup>3</sup>	Bottom 1 Inch Soaked Moisture	33.1 %
Compacted Moisture Content	26.7 %	Average Soaked Moisture	33.5 %
Percent Compaction	100% %	Mass of Surcharge	4.54 kg

Corrected Penetration (mm)	Standard Load of Crushed Stone (kPa)	Corrected Load (kPa)	CBR (%)
2.540	6900	147	<b>2.1</b>
5.080	10300	197	<b>1.9</b>

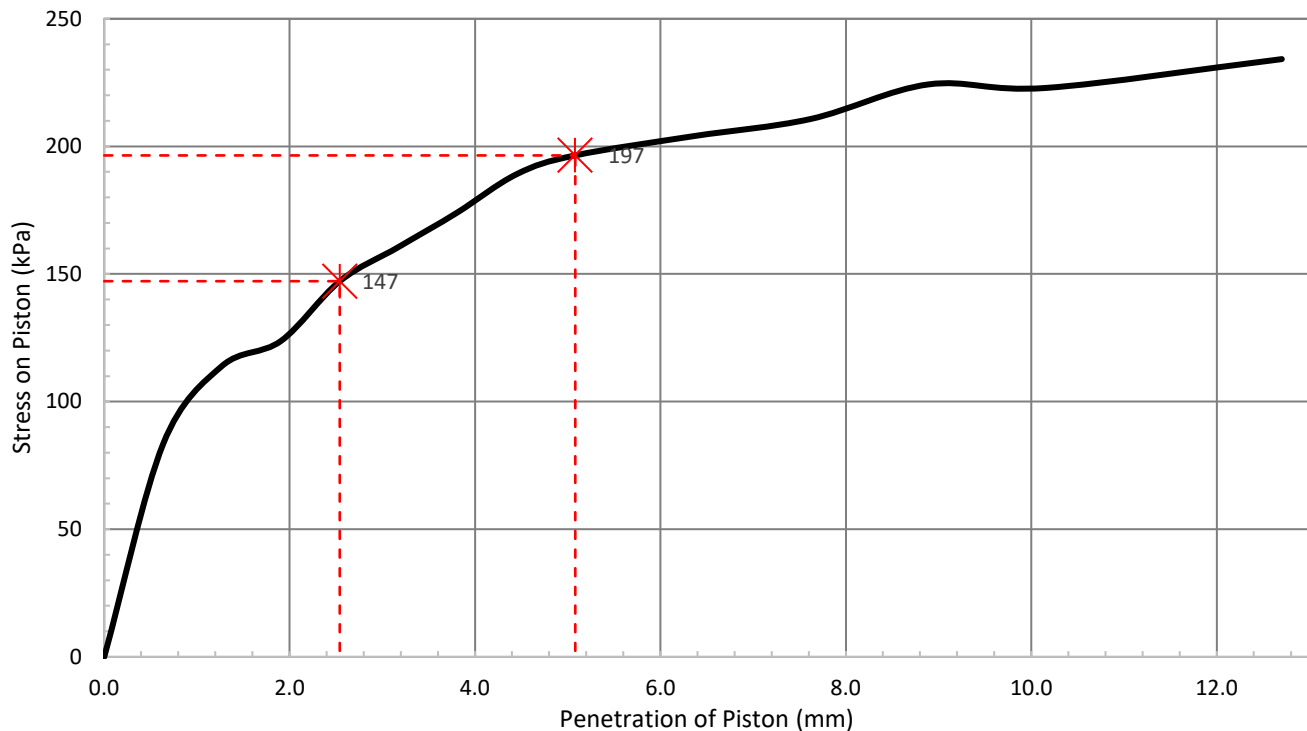

Client: Dillon  
 Project No: WX19175  
 Date: October 1, 2020  
 Technologist: Mdnazri Mohidin

Project: C.O.W. Street Investigation  
 Site Location: DOW-TH01  
 Request No: N/A  
 Reviewed By: Caolan McEvoy

Soil Description: Clay

Liquid Limit \_\_\_\_\_ Plastic Limit \_\_\_\_\_ Plasticity Index \_\_\_\_\_ Swell 0.11%

Reporting of these test results constitutes a testing service only. Engineering interpretation or evaluation of the test results will be provided only upon written request. If you are not the Intended recipient please notify us by telephone as soon as possible and either return the message by post or destroy it. If you are not the intended recipient, any use by you of its contents is prohibited.

# California Bearing Ratio

## ASTM D1883-16, Soaking Method



Wood Environment & Infrastructure Solutions  
a Division of Wood Canada Limited

Type of Preparation	Standard ASTM D698	Sample Preparation	Soaked
Maximum Dry Density	1684 kg/m <sup>3</sup>	Soaking time	96 hrs
Optimum Moisture Content	19.6 %	Top 1 Inch Soaked Moisture	27.6 %
Compacted Dry Density	1674 kg/m <sup>3</sup>	Bottom 1 Inch Soaked Moisture	22.4 %
Compacted Moisture Content	20.1 %	Average Soaked Moisture	24.2 %
Percent Compaction	99% %	Mass of Surcharge	4.54 kg

Corrected Penetration (mm)	Standard Load of Crushed Stone (kPa)	Corrected Load (kPa)	CBR (%)
2.540	6900	176	<b>2.6</b>
5.080	10300	232	<b>2.3</b>

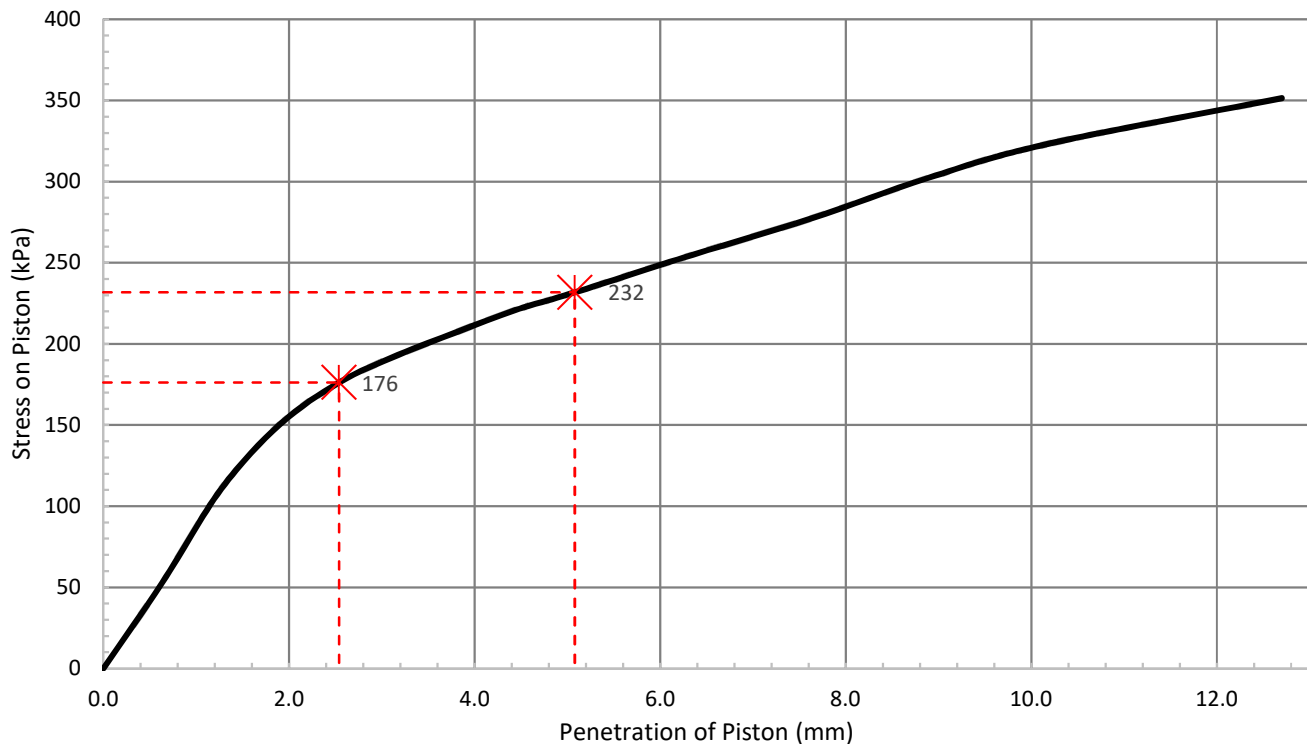

Client: Dillon  
 Project No: WX19175  
 Date: October 16, 2020  
 Technologist: Mdnazri Mohidin

Project: C.O.W. Street Investigation  
 Site Location: TH02-DOW  
 Request No: N/A  
 Reviewed By: Caolan McEvoy

Soil Description: Clay

Liquid Limit \_\_\_\_\_ Plastic Limit \_\_\_\_\_ Plasticity Index \_\_\_\_\_ Swell 0.82%

Reporting of these test results constitutes a testing service only. Engineering interpretation or evaluation of the test results will be provided only upon written request. If you are not the intended recipient please notify us by telephone as soon as possible and either return the message by post or destroy it. If you are not the intended recipient, any use by you of its contents is prohibited.

# California Bearing Ratio

## ASTM D1883-16, Soaking Method



Wood Environment & Infrastructure Solutions  
a Division of Wood Canada Limited

Type of Preparation	Standard ASTM D698	Sample Preparation	Soaked
Maximum Dry Density	1531 kg/m <sup>3</sup>	Soaking time	96 hrs
Optimum Moisture Content	23.9 %	Top 1 Inch Soaked Moisture	32.7 %
Compacted Dry Density	1541 kg/m <sup>3</sup>	Bottom 1 Inch Soaked Moisture	28.8 %
Compacted Moisture Content	24.5 %	Average Soaked Moisture	29.7 %
Percent Compaction	101% %	Mass of Surcharge	4.54 kg

Corrected Penetration (mm)	Standard Load of Crushed Stone (kPa)	Corrected Load (kPa)	CBR (%)
2.540	6900	152	<b>2.2</b>
5.080	10300	188	<b>1.8</b>

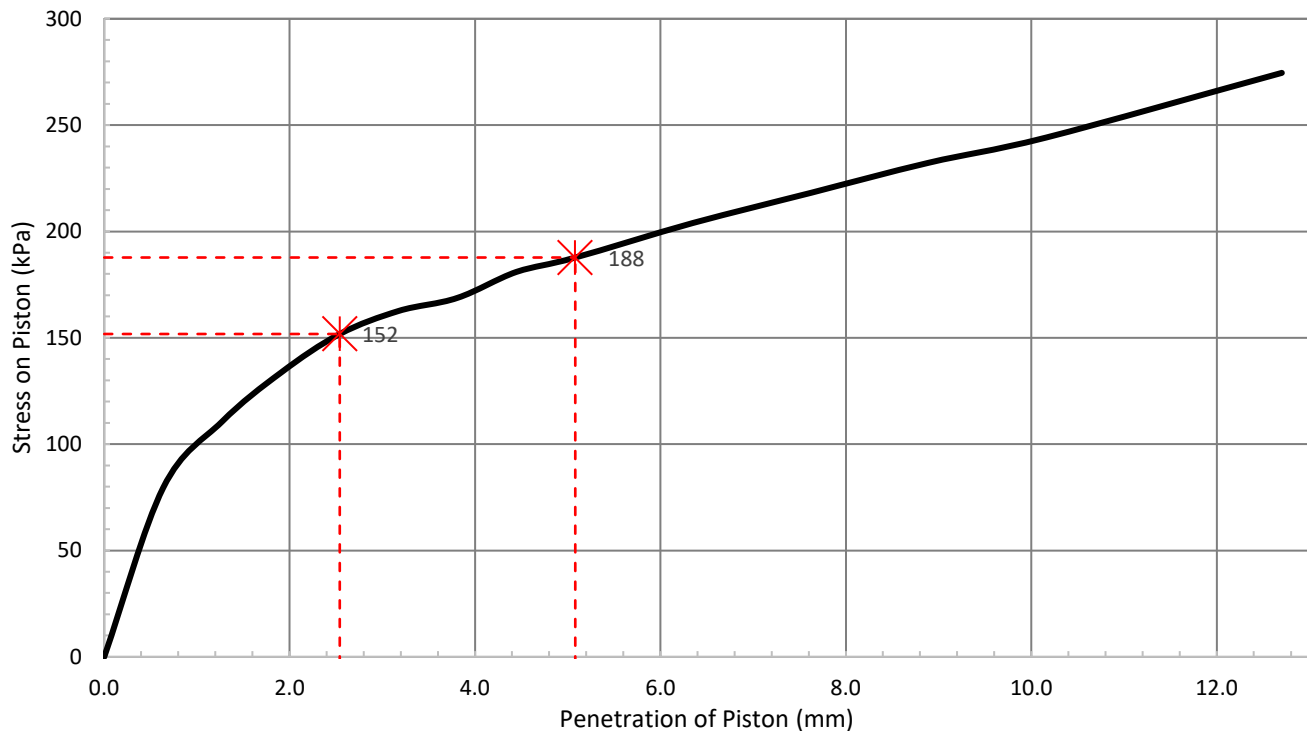

Client: Dillon  
 Project No: WX19175  
 Date: September 26, 2020  
 Technologist: Mdnazri Mohidin

Project: C.O.W. Street Investigation  
 Site Location: RIL-TH01  
 Request No: N/A  
 Reviewed By: Caolan McEvoy

Soil Description: Clay

Liquid Limit \_\_\_\_\_ Plastic Limit \_\_\_\_\_ Plasticity Index \_\_\_\_\_ Swell 0.17%

Reporting of these test results constitutes a testing service only. Engineering interpretation or evaluation of the test results will be provided only upon written request. If you are not the Intended recipient please notify us by telephone as soon as possible and either return the message by post or destroy it. If you are not the intended recipient, any use by you of its contents is prohibited.

**California Bearing Ratio**  
**ASTM D1883-16, Soaking Method**



Wood Environment & Infrastructure Solutions  
 a Division of Wood Canada Limited

Type of Preparation	Standard ASTM D698	Sample Preparation	Soaked
Maximum Dry Density	1398 kg/m <sup>3</sup>	Soaking time	96 hrs
Optimum Moisture Content	28.2 %	Top 1 Inch Soaked Moisture	39.1 %
Compacted Dry Density	1404 kg/m <sup>3</sup>	Bottom 1 Inch Soaked Moisture	37.1 %
Compacted Moisture Content	28.8 %	Average Soaked Moisture	36.8 %
Percent Compaction	100% %	Mass of Surcharge	4.54 kg

Corrected Penetration (mm)	Standard Load of Crushed Stone (kPa)	Corrected Load (kPa)	CBR (%)
2.540	6900	195	<b>2.8</b>
5.080	10300	221	<b>2.1</b>

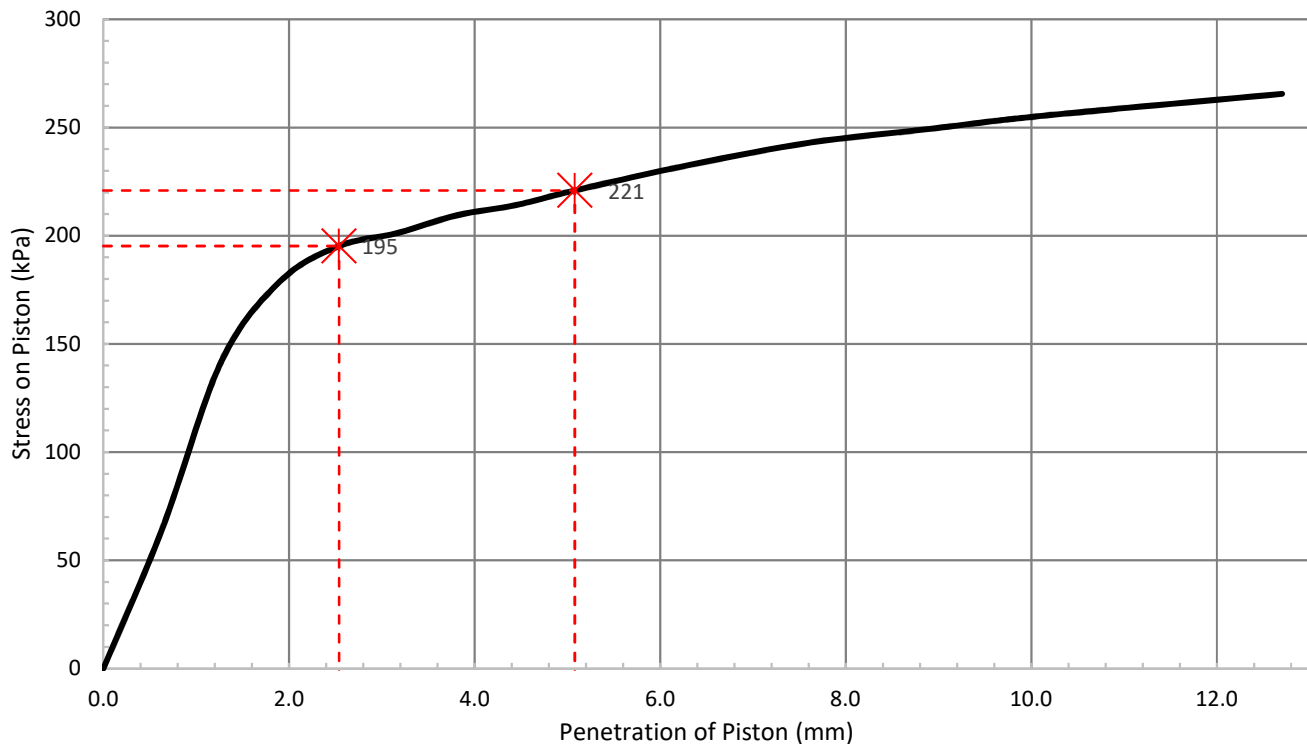

Client: Dillon  
 Project No: WX19175  
 Date: October 16, 2020  
 Technologist: Mdnazri Mohidin

Project: C.O.W. Street Investigation  
 Site Location: TH02-RIL  
 Request No: N/A  
 Reviewed By: Caolan McEvoy

Soil Description: Clay

Liquid Limit \_\_\_\_\_ Plastic Limit \_\_\_\_\_ Plasticity Index \_\_\_\_\_ Swell 0.24%

Reporting of these test results constitutes a testing service only. Engineering interpretation or evaluation of the test results will be provided only upon written request. If you are not the intended recipient please notify us by telephone as soon as possible and either return the message by post or destroy it. If you are not the intended recipient, any use by you of its contents is prohibited.

# California Bearing Ratio

## ASTM D1883-16, Soaking Method



Wood Environment & Infrastructure Solutions  
a Division of Wood Canada Limited

Type of Preparation	Standard ASTM D698	Sample Preparation	Soaked
Maximum Dry Density	1570 kg/m <sup>3</sup>	Soaking time	96 hrs
Optimum Moisture Content	23.5 %	Top 1 Inch Soaked Moisture	31.6 %
Compacted Dry Density	1563 kg/m <sup>3</sup>	Bottom 1 Inch Soaked Moisture	27.9 %
Compacted Moisture Content	23.6 %	Average Soaked Moisture	29.3 %
Percent Compaction	100% %	Mass of Surcharge	4.54 kg

Corrected Penetration (mm)	Standard Load of Crushed Stone (kPa)	Corrected Load (kPa)	CBR (%)
2.540	6900	215	<b>3.1</b>
5.080	10300	262	<b>2.5</b>

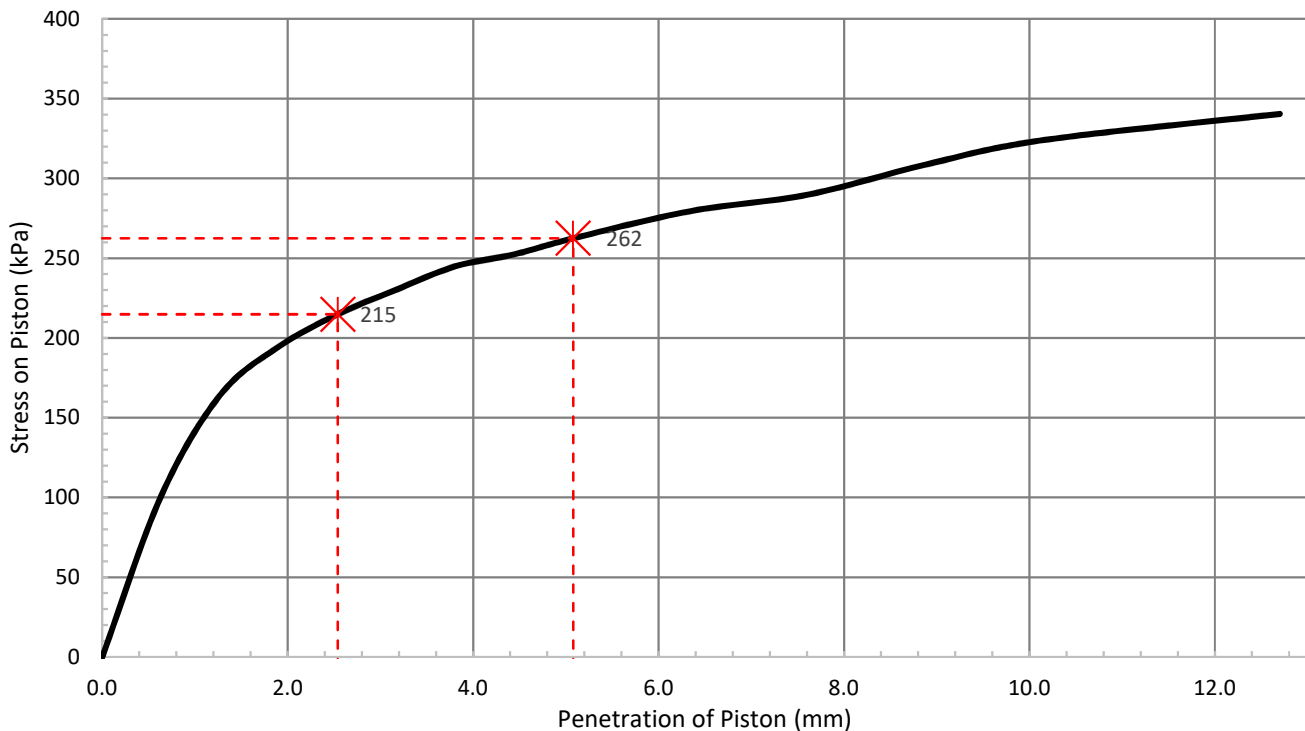

Client: Dillon  
 Project No: WX19175  
 Date: October 20, 2020  
 Technologist: Mdnazri Mohidin

Project: C.O.W. Street Investigation  
 Site Location: TH04-RIL  
 Request No: N/A  
 Reviewed By: Caolan McEvoy

Soil Description: Clay

Liquid Limit \_\_\_\_\_ Plastic Limit \_\_\_\_\_ Plasticity Index \_\_\_\_\_ Swell 0.16%

Reporting of these test results constitutes a testing service only. Engineering interpretation or evaluation of the test results will be provided only upon written request. If you are not the Intended recipient please notify us by telephone as soon as possible and either return the message by post or destroy it. If you are not the intended recipient, any use by you of its contents is prohibited.

# California Bearing Ratio

## ASTM D1883-16, Soaking Method



Wood Environment & Infrastructure Solutions  
a Division of Wood Canada Limited

Type of Preparation	Standard ASTM D698	Sample Preparation	Soaked
Maximum Dry Density	1481 kg/m <sup>3</sup>	Soaking time	96 hrs
Optimum Moisture Content	25.6 %	Top 1 Inch Soaked Moisture	37.1 %
Compacted Dry Density	1488 kg/m <sup>3</sup>	Bottom 1 Inch Soaked Moisture	30.2 %
Compacted Moisture Content	26.0 %	Average Soaked Moisture	32.5 %
Percent Compaction	100% %	Mass of Surcharge	4.54 kg

Corrected Penetration (mm)	Standard Load of Crushed Stone (kPa)	Corrected Load (kPa)	CBR (%)
2.540	6900	153	<b>2.2</b>
5.080	10300	184	<b>1.8</b>

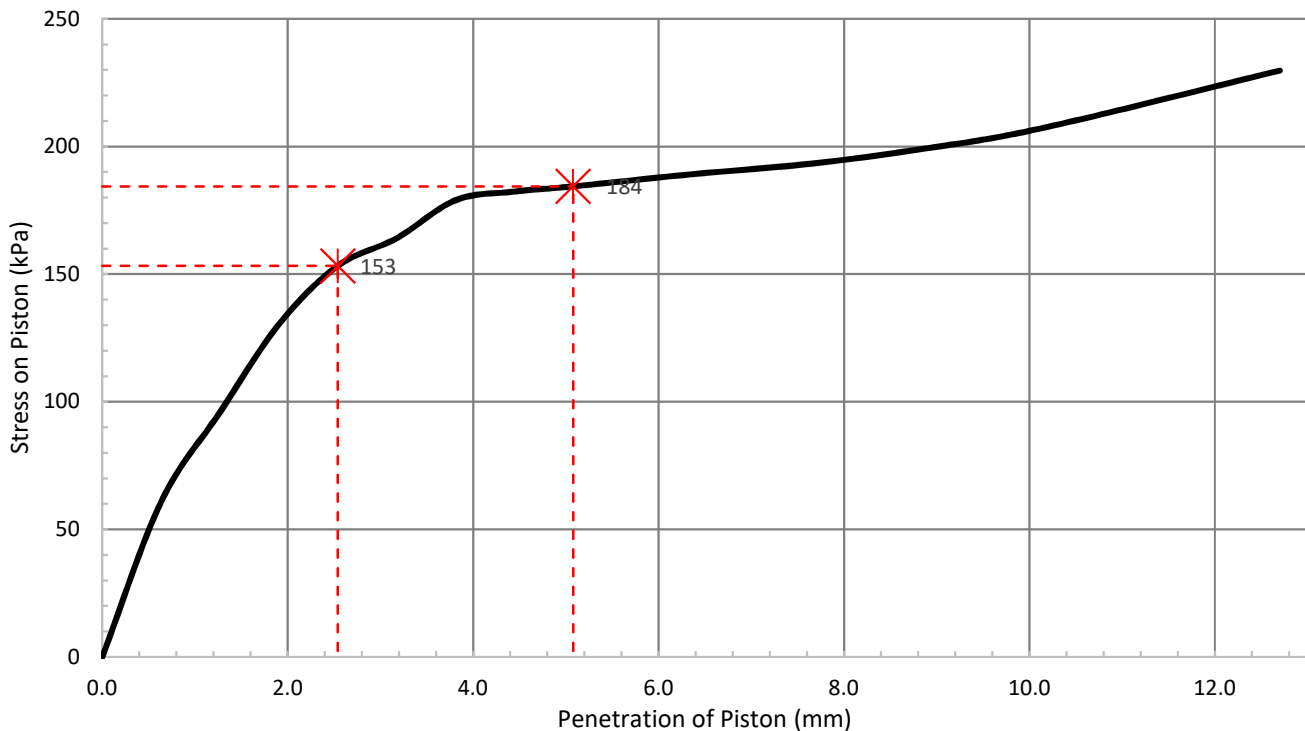

Client: Dillon  
 Project No: WX19175  
 Date: October 23, 2020  
 Technologist: Mdnazri Mohidin

Project: C.O.W. Street Investigation  
 Site Location: GRO-TH01  
 Request No: N/A  
 Reviewed By: Caolan McEvoy

Soil Description: Clay

Liquid Limit \_\_\_\_\_ Plastic Limit \_\_\_\_\_ Plasticity Index \_\_\_\_\_ Swell 0.12%

Reporting of these test results constitutes a testing service only. Engineering interpretation or evaluation of the test results will be provided only upon written request. If you are not the Intended recipient please notify us by telephone as soon as possible and either return the message by post or destroy it. If you are not the intended recipient, any use by you of its contents is prohibited.

# California Bearing Ratio

## ASTM D1883-16, Soaking Method



Wood Environment & Infrastructure Solutions  
a Division of Wood Canada Limited

Type of Preparation	Standard ASTM D698	Sample Preparation	Soaked
Maximum Dry Density	1353 kg/m <sup>3</sup>	Soaking time	96 hrs
Optimum Moisture Content	31.7 %	Top 1 Inch Soaked Moisture	44.4 %
Compacted Dry Density	1360 kg/m <sup>3</sup>	Bottom 1 Inch Soaked Moisture	38.7 %
Compacted Moisture Content	26.7 %	Average Soaked Moisture	40.1 %
Percent Compaction	101% %	Mass of Surcharge	4.54 kg

Corrected Penetration (mm)	Standard Load of Crushed Stone (kPa)	Corrected Load (kPa)	CBR (%)
2.540	6900	133	<b>1.9</b>
5.080	10300	161	<b>1.6</b>

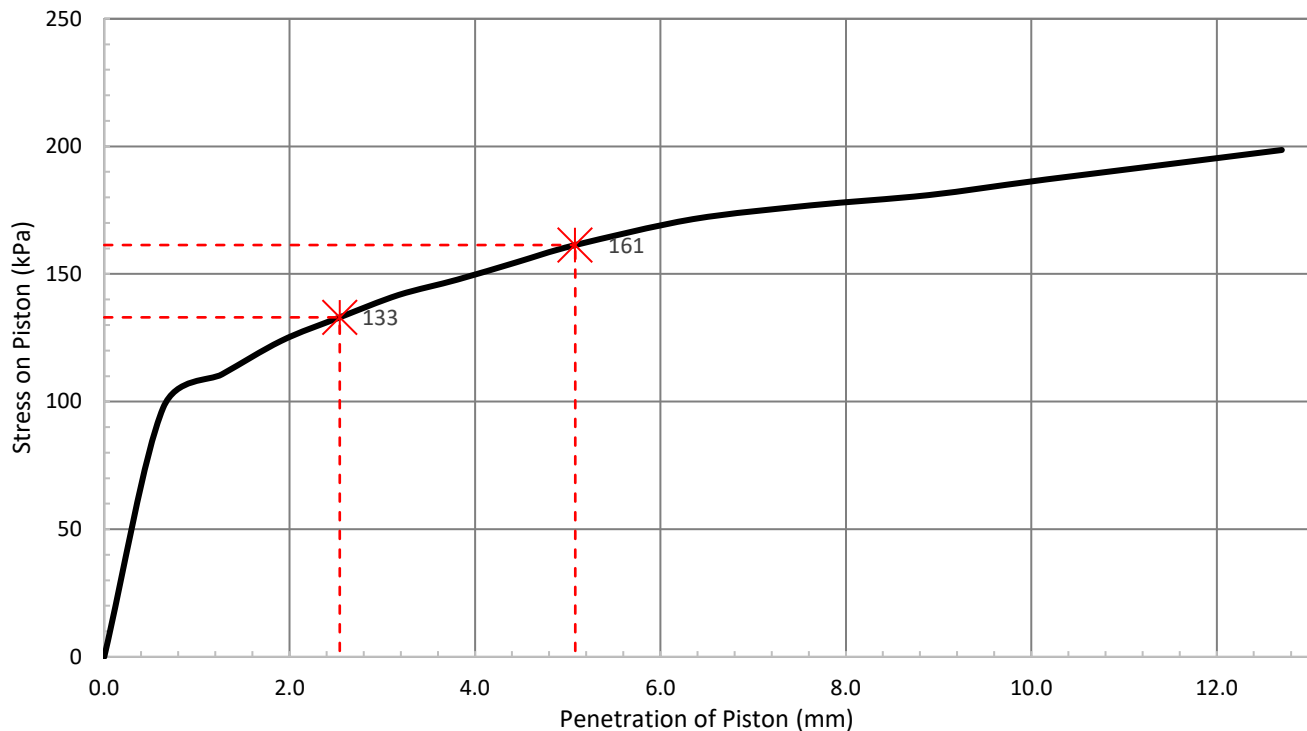

Client: Dillon  
 Project No: WX19175  
 Date: October 1, 2020  
 Technologist: Mdnazri Mohidin

Project: C.O.W. Street Investigation  
 Site Location: GRO-TH02  
 Request No: N/A  
 Reviewed By: Caolan McEvoy

Soil Description: Clay

Liquid Limit \_\_\_\_\_ Plastic Limit \_\_\_\_\_ Plasticity Index \_\_\_\_\_ Swell 0.23%

Reporting of these test results constitutes a testing service only. Engineering interpretation or evaluation of the test results will be provided only upon written request. If you are not the Intended recipient please notify us by telephone as soon as possible and either return the message by post or destroy it. If you are not the intended recipient, any use by you of its contents is prohibited.



# California Bearing Ratio

## ASTM D1883-16, Soaking Method



Wood Environment & Infrastructure Solutions  
a Division of Wood Canada Limited

Type of Preparation	Standard ASTM D698	Sample Preparation	Soaked
Maximum Dry Density	1360 kg/m <sup>3</sup>	Soaking time	96 hrs
Optimum Moisture Content	31.1 %	Top 1 Inch Soaked Moisture	47.8 %
Compacted Dry Density	1366 kg/m <sup>3</sup>	Bottom 1 Inch Soaked Moisture	43.6 %
Compacted Moisture Content	31.3 %	Average Soaked Moisture	41.3 %
Percent Compaction	100% %	Mass of Surcharge	4.54 kg

Corrected Penetration (mm)	Standard Load of Crushed Stone (kPa)	Corrected Load (kPa)	CBR (%)
2.540	6900	99	<b>1.4</b>
5.080	10300	120	<b>1.2</b>

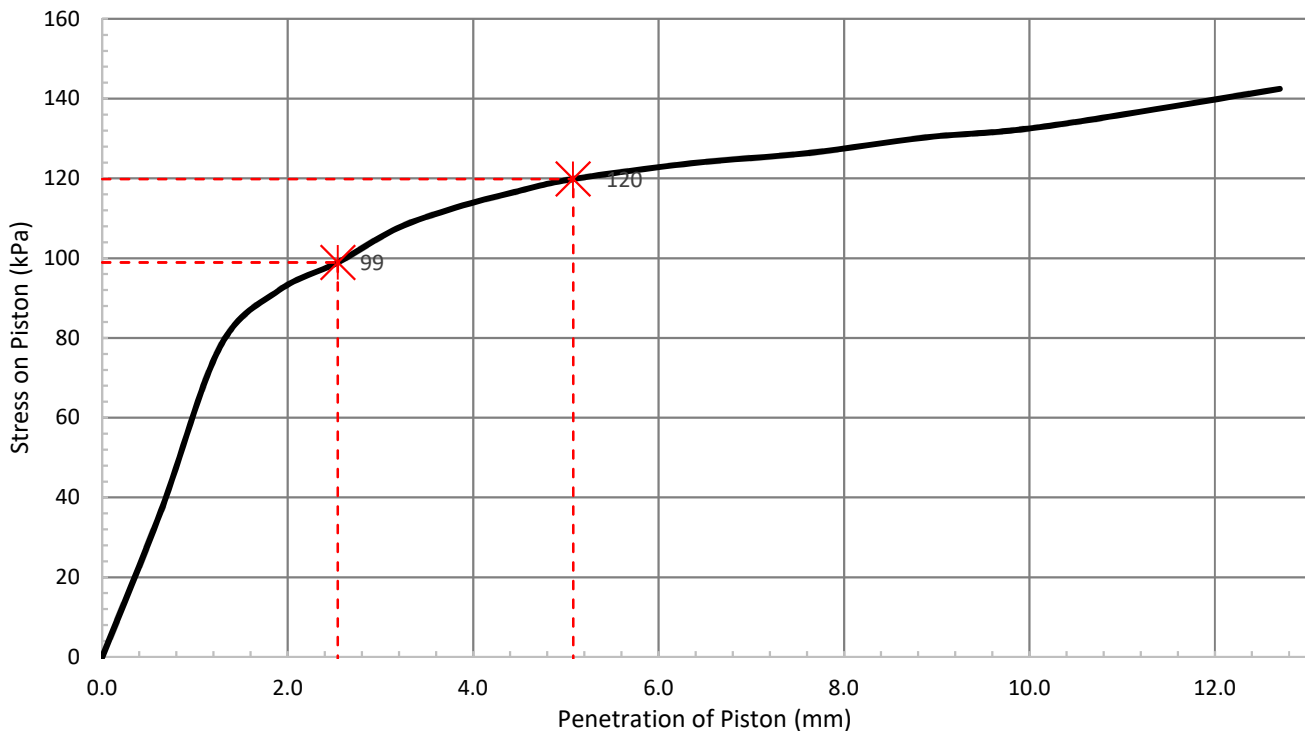

Client: Dillon  
 Project No: WX19175  
 Date: October 23, 2020  
 Technologist: Mdnazri Mohidin

Project: C.O.W. Street Investigation  
 Site Location: TH01-Rock  
 Request No: N/A  
 Reviewed By: Caolan McEvoy

Soil Description: Clay

Liquid Limit \_\_\_\_\_ Plastic Limit \_\_\_\_\_ Plasticity Index \_\_\_\_\_ Swell 0.86%

Reporting of these test results constitutes a testing service only. Engineering interpretation or evaluation of the test results will be provided only upon written request. If you are not the Intended recipient please notify us by telephone as soon as possible and either return the message by post or destroy it. If you are not the intended recipient, any use by you of its contents is prohibited.

# California Bearing Ratio

## ASTM D1883-16, Soaking Method



Wood Environment & Infrastructure Solutions  
a Division of Wood Canada Limited

Type of Preparation	Standard ASTM D698	Sample Preparation	Soaked
Maximum Dry Density	1455 kg/m <sup>3</sup>	Soaking time	96 hrs
Optimum Moisture Content	27.8 %	Top 1 Inch Soaked Moisture	37.5 %
Compacted Dry Density	1462 kg/m <sup>3</sup>	Bottom 1 Inch Soaked Moisture	31.4 %
Compacted Moisture Content	28.1 %	Average Soaked Moisture	33.0 %
Percent Compaction	100% %	Mass of Surcharge	4.54 kg

Corrected Penetration (mm)	Standard Load of Crushed Stone (kPa)	Corrected Load (kPa)	CBR (%)
2.540	6900	153	<b>2.2</b>
5.080	10300	178	<b>1.7</b>

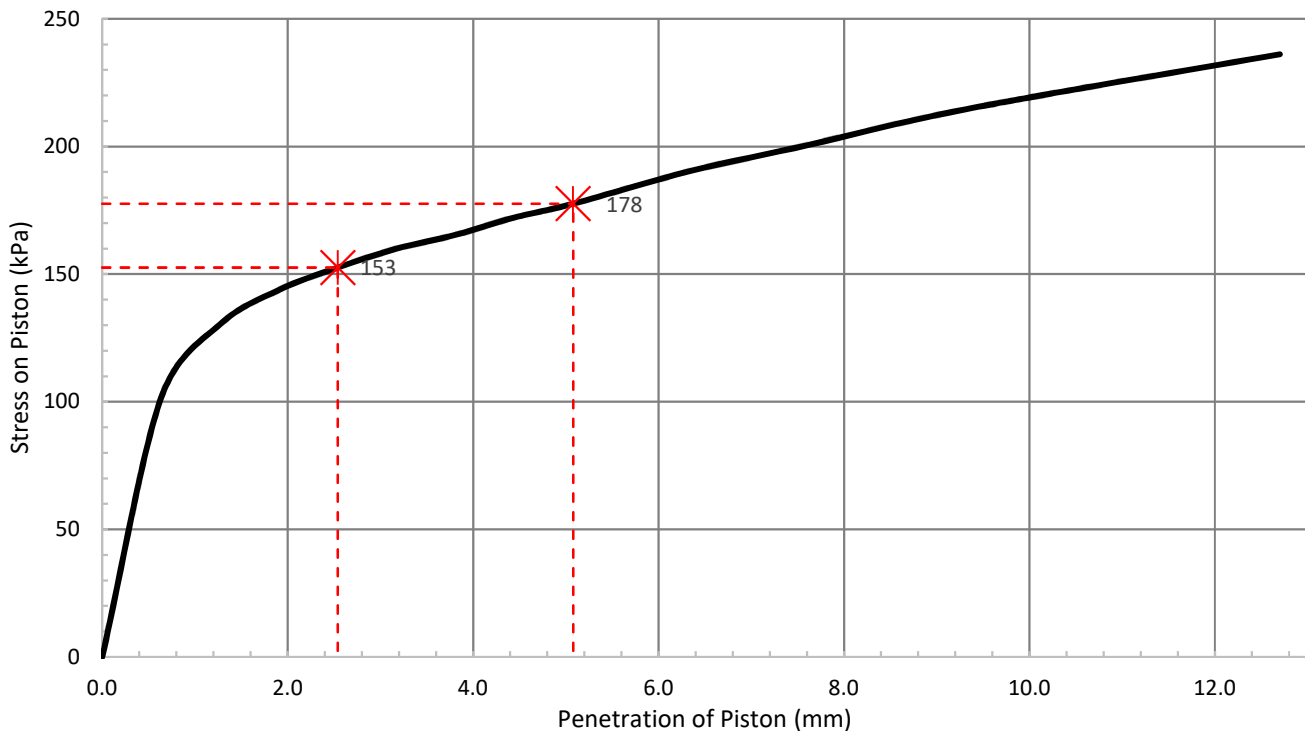

Client: Dillon  
 Project No: WX19175  
 Date: October 27, 2020  
 Technologist: Mdnazri Mohidin

Project: C.O.W. Street Investigation  
 Site Location: ROCK-TH02  
 Request No: N/A  
 Reviewed By: Caolan McEvoy

Soil Description: Clay

Liquid Limit \_\_\_\_\_ Plastic Limit \_\_\_\_\_ Plasticity Index \_\_\_\_\_ Swell 0.56%

Reporting of these test results constitutes a testing service only. Engineering interpretation or evaluation of the test results will be provided only upon written request. If you are not the Intended recipient please notify us by telephone as soon as possible and either return the message by post or destroy it. If you are not the intended recipient, any use by you of its contents is prohibited.

# California Bearing Ratio

## ASTM D1883-16, Soaking Method



Wood Environment & Infrastructure Solutions  
a Division of Wood Canada Limited

Type of Preparation	Standard ASTM D698	Sample Preparation	Soaked
Maximum Dry Density	1389 kg/m <sup>3</sup>	Soaking time	96 hrs
Optimum Moisture Content	31 %	Top 1 Inch Soaked Moisture	47.2 %
Compacted Dry Density	1381 kg/m <sup>3</sup>	Bottom 1 Inch Soaked Moisture	35.4 %
Compacted Moisture Content	30.8 %	Average Soaked Moisture	39.7 %
Percent Compaction	99% %	Mass of Surcharge	4.54 kg

Corrected Penetration (mm)	Standard Load of Crushed Stone (kPa)	Corrected Load (kPa)	CBR (%)
2.540	6900	116	<b>1.7</b>
5.080	10300	130	<b>1.3</b>

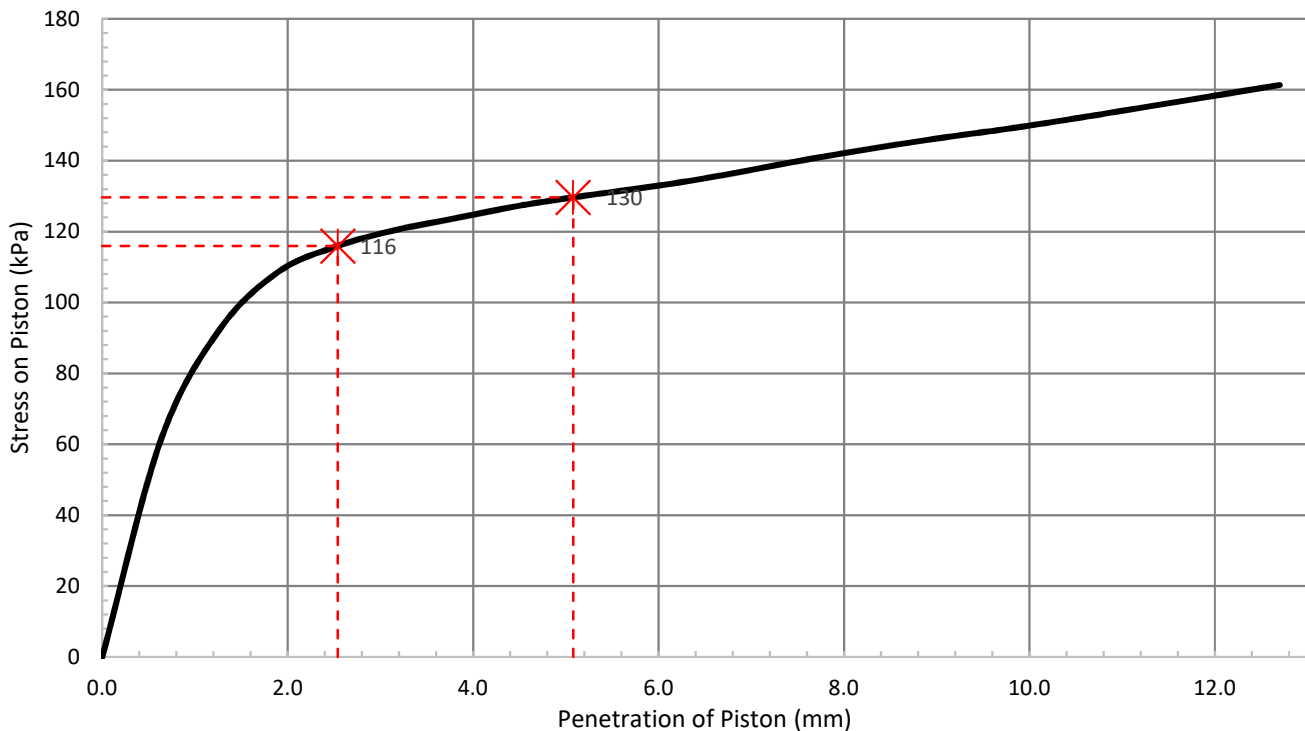

Client: Dillon  
 Project No: WX19175  
 Date: October 23, 2020  
 Technologist: Mdnazri Mohidin

Project: C.O.W. Street Investigation  
 Site Location: TH01-Har  
 Request No: N/A  
 Reviewed By: Caolan McEvoy

Soil Description: Clay

Liquid Limit \_\_\_\_\_ Plastic Limit \_\_\_\_\_ Plasticity Index \_\_\_\_\_ Swell 0.71%

Reporting of these test results constitutes a testing service only. Engineering interpretation or evaluation of the test results will be provided only upon written request. If you are not the Intended recipient please notify us by telephone as soon as possible and either return the message by post or destroy it. If you are not the intended recipient, any use by you of its contents is prohibited.

# California Bearing Ratio

## ASTM D1883-16, Soaking Method



Wood Environment & Infrastructure Solutions  
a Division of Wood Canada Limited

Type of Preparation	Standard ASTM D698	Sample Preparation	Soaked
Maximum Dry Density	1364 kg/m <sup>3</sup>	Soaking time	96 hrs
Optimum Moisture Content	30.9 %	Top 1 Inch Soaked Moisture	49.1 %
Compacted Dry Density	1369 kg/m <sup>3</sup>	Bottom 1 Inch Soaked Moisture	34.9 %
Compacted Moisture Content	30.7 %	Average Soaked Moisture	40.1 %
Percent Compaction	100% %	Mass of Surcharge	4.54 kg

Corrected Penetration (mm)	Standard Load of Crushed Stone (kPa)	Corrected Load (kPa)	CBR (%)
2.540	6900	97	<b>1.4</b>
5.080	10300	119	<b>1.2</b>

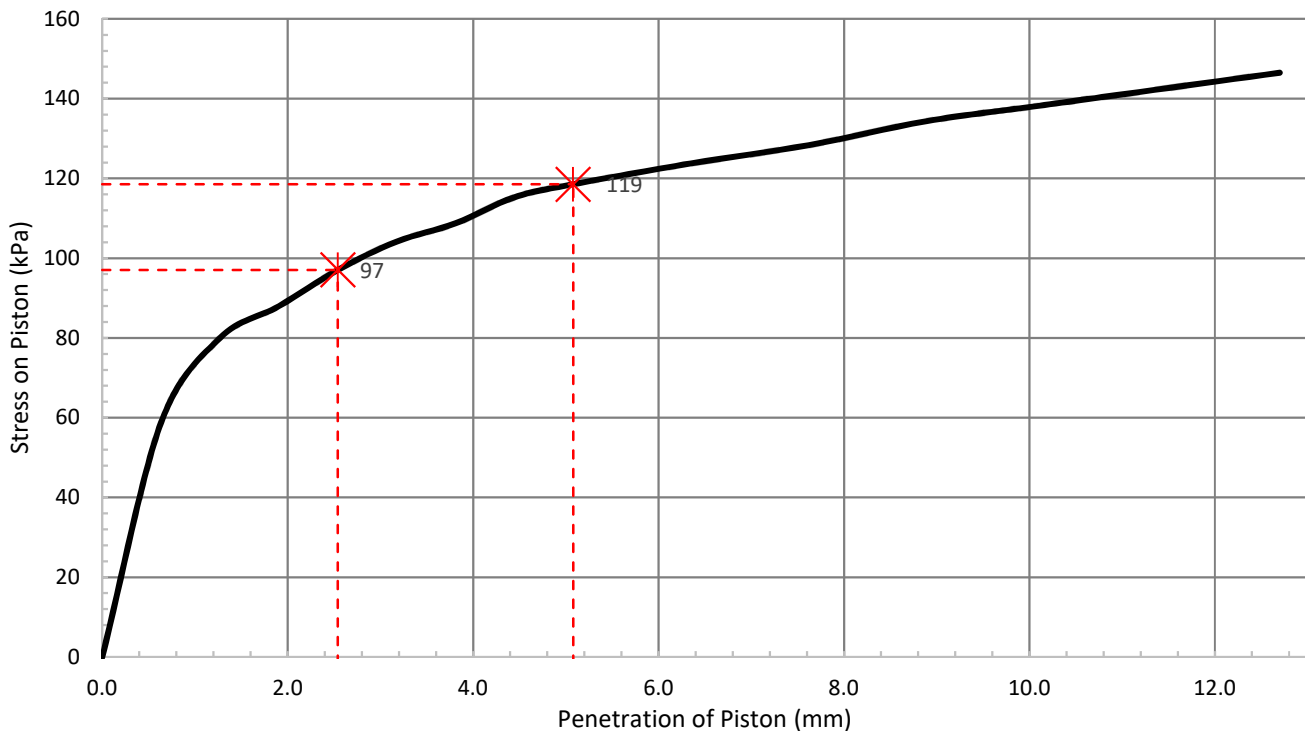

Client: Dillon  
 Project No: WX19175  
 Date: October 23, 2020  
 Technologist: Mdnazri Mohidin

Project: C.O.W. Street Investigation  
 Site Location: TH02-Har  
 Request No: N/A  
 Reviewed By: Caolan McEvoy

Soil Description: Clay

Liquid Limit \_\_\_\_\_ Plastic Limit \_\_\_\_\_ Plasticity Index \_\_\_\_\_ Swell 1.36%

Reporting of these test results constitutes a testing service only. Engineering interpretation or evaluation of the test results will be provided only upon written request. If you are not the Intended recipient please notify us by telephone as soon as possible and either return the message by post or destroy it. If you are not the intended recipient, any use by you of its contents is prohibited.

## **APPENDIX 'B'**

# **MANITOBA HYDRO ELECTRICAL STANDARDS – 2019 STREET LIGHT INSTALLATIONS**



**Appendix A**  
**Electrical Standards**  
**(2019 Streetlight Installations)**

**Refer to electronic copy issued under separate cover**

## **Electric Standards for Streetlight Installations Table of Contents**

50-7	Sheet 1 of 1	Ground Rod Material Detail
200-63	Sheet 1 & 2 of 2	Cable Guard Details on DIP/Riser Poles
210-12	Sheets 1 & 2 of 2	Underground Secondary Cable
210-15	Sheet 1 of 1	Standard Underground Secondary Cable Data
210-21	Sheet 1 of 1	Underground Secondary Cable Compression Connectors
210-24	Sheet 1 of 1	Underground Neutral Compression Connectors
215-12	Sheets 1, 2 & 3 of 3	Primary and Secondary Cable End Caps
215-13	Sheets 1 & 2 of 2	Splicing Secondary Neutral (Bare Copper to Insulated Aluminum)
300-1	Sheet 1 of 1	Standard Steel Street Light Poles
300-6	Sheets 1 & 2 of 3	Installation of Precast Concrete Base
300-9	Sheet 1 of 1	Method for Anchor Rod Tightening
300-10	Sheets 1 & 2 of 2	Breakaway Base Installation
300-18	Sheet 1 of 1	Rigging Weights of Street Light Components
300-24	Sheet 1 of 2	Standard LED Luminaires
305-1	Sheets 1 & 2 of 2	Plowing and Trenching Details for Underground Street Light Circuits
310-1	Sheets 1 & 2 of 2	Installation of Street Light Cables
310-3	Sheets 1 to 3 of 3	Raychem Gelcap Splice
310-4	Sheets 1 to 4 of 4	Connection Detail on Steel Street Light Standard
310-9	Sheets 1 to 4 of 4	Street Light Circuit Protected by 30A Fuse in Streetlight Standard
310-10	Sheets 1 to 4 of 4	Street Light Circuit Protected by 15A Fuse in Streetlight Standard
315-1	Sheet 1 of 1	Supply Voltages Street Light Circuits
315-2	Sheet 1 of 1	240/308v for Street Light Circuits
315-5	Sheet 1 of 1	DIP Pole for Underground Street Light Circuit
315-10	Sheet 1 of 1	Control Methods for Street Light Controls
315-12	Sheet 1 of 1	Installation of Externally-Mounted Relay
315-13	Sheet 1 of 1	Connection Schematic for Externally-Mounted Relay
315-35	Sheet 1 of 1	Identification of First Street Light Standard Connected to Circuit

Updated: February 11, 2019

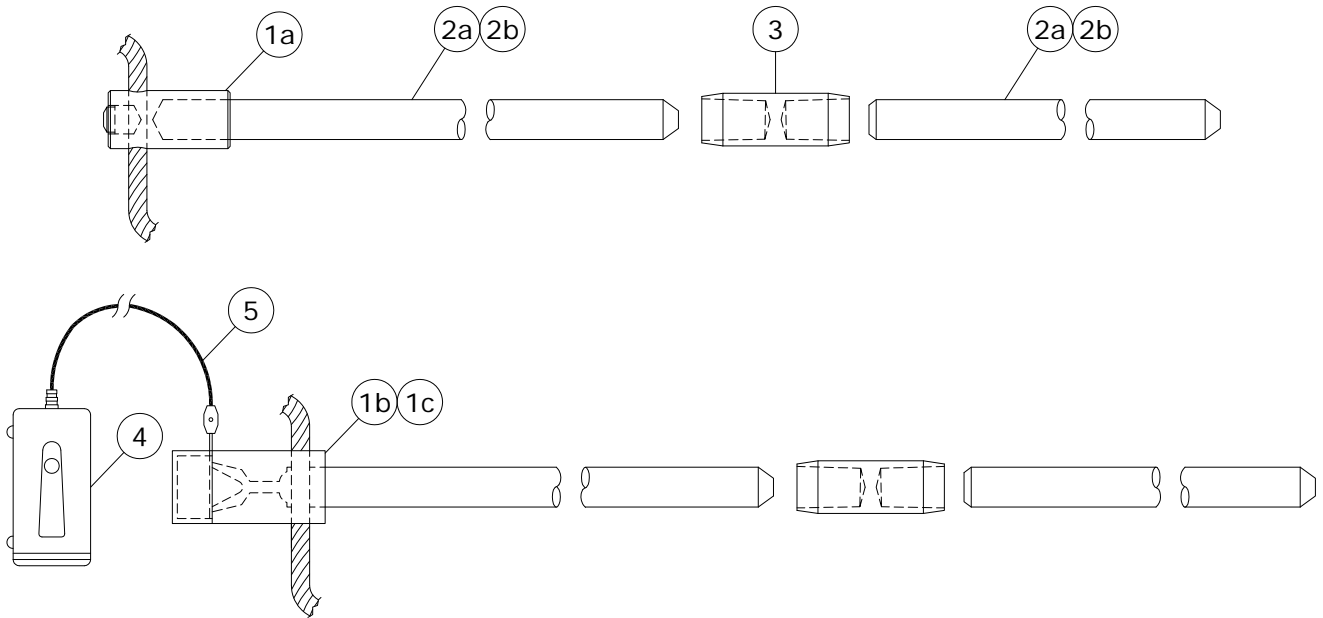

**COPPERWELD - SECTIONAL**

ITEM No.	DESCRIPTION	MH CIIC
1a	HAMMERLOCK FOR #2 & #4 CU	04 60 24
1b	ONE SHOT PLUS FOR 2/0	03 59 15
1c	ONE SHOT PLUS FOR 4/0	03 77 06
2a	10' CU-WELD ROD SECTIONAL (SEE NOTE 2)	71 70 10
2b	6' CU-WELD ROD SECTIONAL	00 68 26
3	COUPLING CU-WELD	00 52 27
4	ELECTRONIC IGNITER FOR ONE SHOT PLUS WITH 15' CORD	03 59 10
5	15' REPLACEMENT CORD	03 67 43

**NOTES:**

- FOR 3/4" GROUND RODS. IF A 5/8" GROUND ROD IS ENCOUNTERED, IT IS TO BE REPLACED WITH A 3/4" ROD.
- FIRST GROUND ROD SHALL BE A 10' ROD.

APPROVED  ORIGINAL DRAWING SEALED BY E.H. WIEBE 99-01-04	REVISIONS			MANITOBA HYDRO DISTRIBUTION STANDARDS	
	13-01	3	ADDED HAMMERLOCK CONNECTOR	<b>GROUND ROD MATERIAL DETAIL</b>	
	08-07	2	ADDED ELECTRONIC IGNITER & REVISED TABLE		
00-08	1	REMOVED STEEL AND GALVANIZED RODS, ONE SHOT ADDED			
DRAWN R.L.B./CAD	CHECKED D.F./D.O.	DATE 98-08	<b>CD 50-7</b>		SHT 0001 OF 1
					REV 03



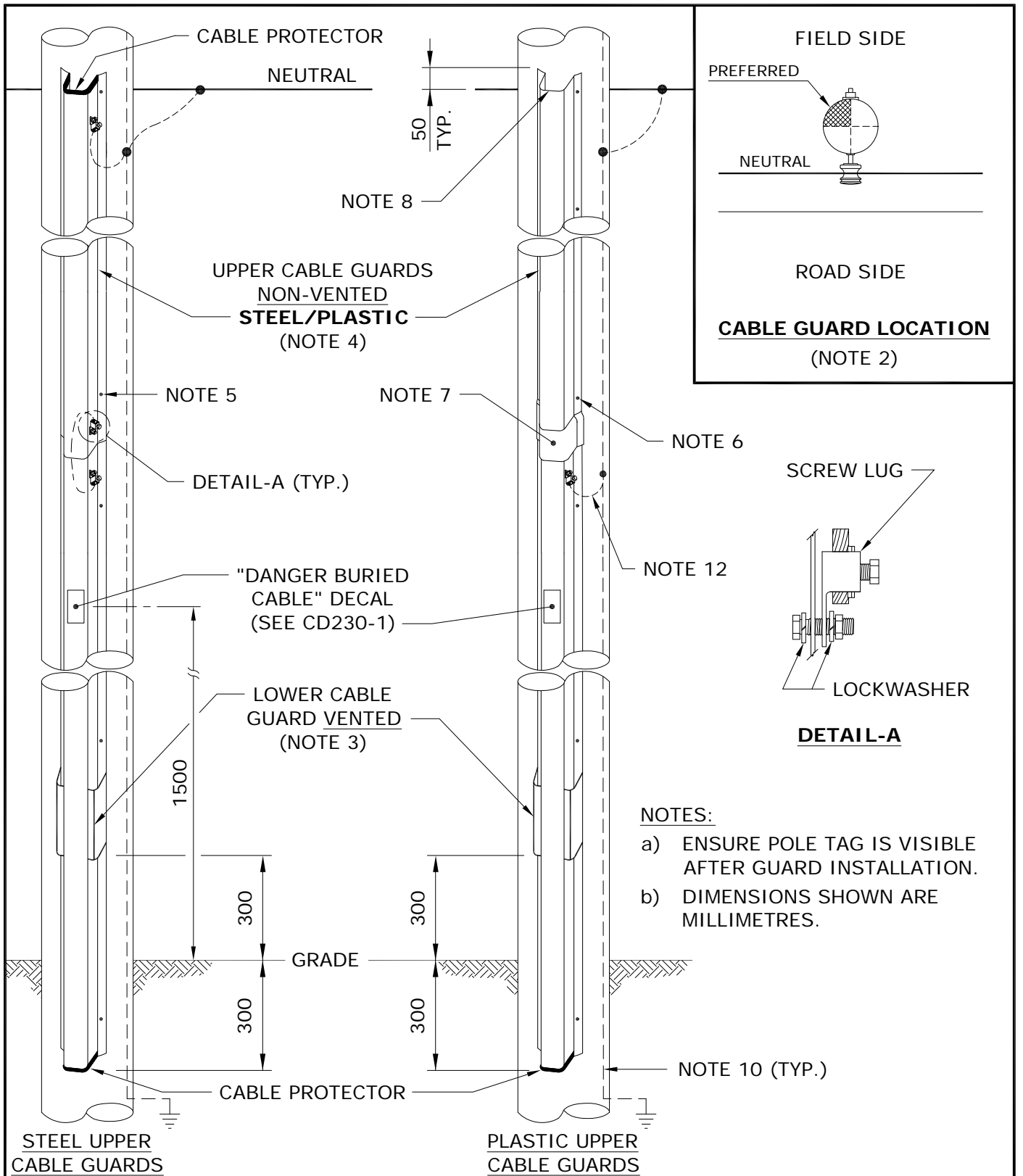

SUPERCEDES ORIGINAL SEALED BY E. WIEBE ON 94-07-03

APPROVED		REVISIONS		MANITOBA HYDRO DISTRIBUTION STANDARDS	
ORIGINAL DRAWING SEALED BY J.J.D. RINGASH 15-10-29	16-04	4	REVISED NOTE	<b>CABLE GUARD DETAILS ON DIP/RISER POLES</b>	
	15-10	3	ADDED NOTE a), RESEALED		
	99-10	2	PLASTIC CABLE GUARD AND SHEET 2 ADDED		
DRAWN C.A.	CHECKED J.R.	DATE 15-10		<b>CD 200-63</b>	
				SHT	REV
				0001 OF 2	04

NOTES:

1. FOR CABLE GUARD SELECTION GUIDE, REFER TO DRAWING CD200-66.
2. TO PROVIDE A SAFER CLIMBING SURFACE AND TO PREVENT VEHICULAR DAMAGE TO THE CABLE GUARD, THE PREFERRED ATTACHMENT OF THE CABLE GUARD TO THE POLE SHOULD BE IN THE QUADRANT AS SHOWN.
3. THE LOWER CABLE GUARD SHALL BE GALVANIZED STEEL AND VENTED.
4. UPPER CABLE GUARD SHALL BE PLASTIC FOR THE 50mm & 90mm GUARDS AND GALVANIZED STEEL FOR THE 130mm GUARD.
5. ATTACH GALVANIZED STEEL CABLE GUARD TO POLE WITH 3/8" LAG SCREWS (72-60-03).
6. ATTACH THE PLASTIC CABLE GUARD TO THE POLE WITH #16 x 2" WOOD SCREWS (72-95-10), C/W FLAT WASHERS (86-10-04).
7. POSITION THE LAP-JOINT OF THE PLASTIC CABLE GUARD DOWN & OVER LAPPED A MINIMUM OF 25mm ONTO THE VENTED CABLE GUARD.
8. ENSURE THAT THE INNER EDGE IS BEVELLED.
9. CABLE GUARD TO EXTEND 50mm ABOVE THE NEUTRAL CONDUCTOR.
10. GROUNDING AND BONDING CONDUCTORS SHALL BE #4 BARE COPPER.
11. FOR GROUNDING CONNECTIONS, REFER TO DRAWING CD200-60.
12. BOND VENTED CABLE GUARD AT THIS POINT.

*SUPERCEDES ORIGINAL SEALED BY E. WIEBE ON 99-11-03*

APPROVED		REVISIONS		MANITOBA HYDRO DISTRIBUTION STANDARDS		
ORIGINAL DRAWING SEALED BY J.J.D. RINGASH 15-10-29				<b>CABLE GUARD DETAILS ON DIP/RISER POLES</b>		
		16-04	2			ADDED FLAT WASHERS TO NOTE 6
		15-10	1			RESEALED
DRAWN C.A.	CHECKED J.R.	DATE 15-10	<b>CD 200-63</b>		SHT 0002 OF 2	
					REV 02	

SECONDARY CABLE	TYPICAL USAGE
#4 AL. CONCENTRIC NEUTRAL	STREET LIGHT CIRCUITS
1/0 AL. TRIPLEX	SECONDARY RESIDENTIAL SERVICES AND HEAVILY LOADED STREET LIGHT CIRCUITS WHERE VOLTAGE DROP MAY BE A PROBLEM
4/0 AL. TRIPLEX	SECONDARY RESIDENTIAL SERVICES
350 TRIPLEX	SECONDARY RESIDENTIAL SERVICES
4/0 AL. TRIPLEX	THREE PHASE SECONDARY SERVICES ADD #2 Cu BARE NEUTRAL UP TO 200 AMP
350 AL. QUADRAPLEX	THREE PHASE SECONDARY SERVICES 400 AMP OR 200A OVER 75m
750 AL. OR 1000 CU.	THREE PHASE SECONDARY SERVICES OVER 400 AMPS

NOTE:

SEE CD225-4 FOR SIZING AND SPACING OF SINGLE AND THREE PHASE CONDUCTORS.

*SUPERCEDES ORIGINAL SEALED BY E. WIEBE ON 88-03-29*

APPROVED		REVISIONS		MANITOBA HYDRO DISTRIBUTION STANDARDS	
ORIGINAL DRAWING SEALED BY J.J.D. RINGASH 17-01-25	17-01	11	ADDED 4/0 AL TRIPLEX TO TABLE, RESEALED	<b>UNDERGROUND SECONDARY CABLE</b>	
	06-03	10	ADDED NOTE AND 350 TRIPLEX		
	99-04	9	4/0 AL. TRIPLEX, NOTE CHANGED		
DRAWN C.A.	CHECKED K.S.	DATE 17-01	<b>CD 210-12</b>		SHT 0001 OF 2
					REV 11

# BASIC CONSTRUCTION OF UNDERGROUND SECONDARY CABLES

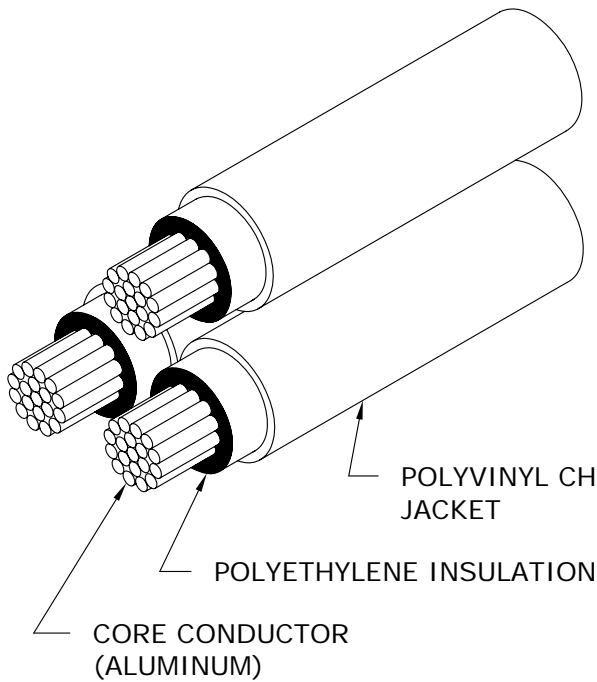

**1/0 & 4/0 AND 350 TRIPLEX**

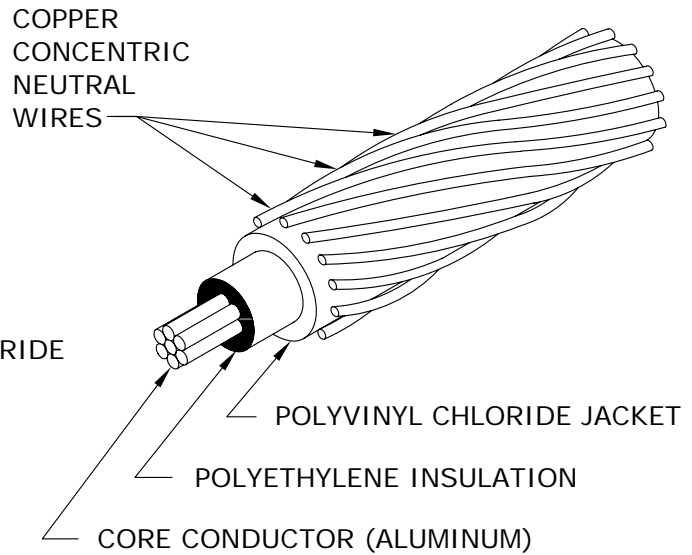

**# 4 CONCENTRIC NEUTRAL CABLE**

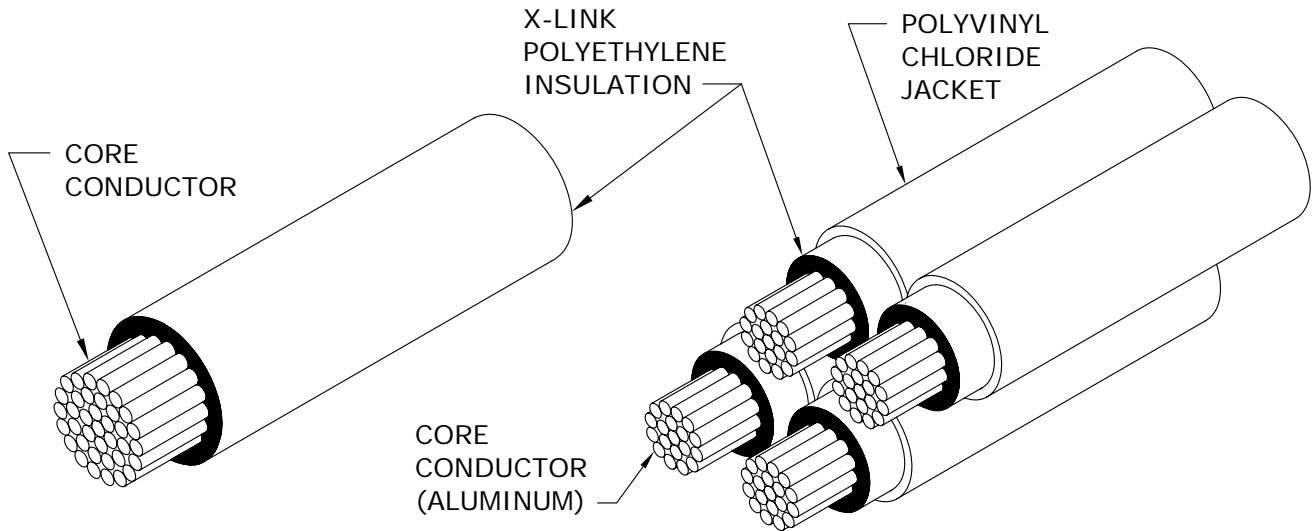

**750 kcmil (AL) & 1000 kcmil (CU) RWU**

**350 kcmil QUADRAPLEX**

APPROVED	REVISIONS			MANITOBA HYDRO DISTRIBUTION STANDARDS			
ORIGINAL DRAWING SEALED BY E.H. WIEBE 94-07-03	06-03	2	REPLACED 4/0 TRIPLEX WITH 4/0 & 350 TRIPLEX	<b>UNDERGROUND SECONDARY CABLE</b>			
	95-01	1	C/N WIRES NO LONGER TINNED				
	93-07	0	500 MCM DELETED 350 750 kcmil ADDED FORMERLY CD210-3				
DRAWN W.B./CAD	CHECKED B.H.	DATE 93-07	<b>CD 210-12</b>			SHT 0002 OF 2	REV 02

## UNDERGROUND SECONDARY CABLE

VOLTAGE RATING	600V	600V	600V	600V	1000V	1000V	1000V
CORE CONDUCTOR SIZE	#4	1/0	4/0	350 kcmil	750 kcmil	1000 kcmil	1000 kcmil
CORE CONDUCTOR MATERIAL	ALUM.	ALUM.	ALUM.	ALUM.	ALUM.	ALUM.	COPPER
TYPE OF CABLE	C/N	TRIPLEX	TRIPLEX	TRIPLEX OR QUADPLEX	1-COND.	1-COND.	1-COND.
NEUTRAL SIZE AND TYPE	#6 CU. Concentric Neutral	1/0 ALUM.	4/0 ALUM.	350 kcmil ALUM.	NONE	NONE	NONE
MIN. BENDING RADIUS (mm)	125	115	150	180	250	300	300
DC RESISTANCE @ 20°C (OHMS/km)	1.360	0.538	0.269	0.163	0.076	0.057	0.035
** DIRECT BURIED AMPACITY (@ 20°C ambient)	125	215	300	420	* 725	* 840	* 1080
VENTED CABLE GUARD AMPACITY (@ 20°C ambient)	100	175	250	330	575	680	855
*** BURIED DUCT AMPACITY (@ 20°C ambient)	70	130	195	265	425	495	630
CONDUCTOR DIAMETER (mm)	5.4	8.9	12.7	15.8	25	26.9	26.9
NOMINAL DIA. OVER INSUL. (mm)	8.6	12.5	16.5	21.6	31.4	33.5	33.5
NOMINAL DIA. OVER JACKET (mm)	12.74	14.7	17.8	22.8	N/A	N/A	N/A
LINEAL MASS (kg/km)	N/A	760	1320	2200/2900	1330	1369	4983
COLD SHRINK END CAPS (MH CIIC)	N/A	15 31 40	15 31 40	15 31 60	15 31 75	15 31 75	15 31 75
HEAT SHRINK END CAPS (MH CIIC)	03 67 31	03 67 31	03 67 31	03 67 30	01 79 82	03 48 63	03 48 63

\* PROVIDED MULTIPLE CONDUCTORS PER PHASE ARE SPACED AS SHOWN IN DRAWING CD225-4.

\*\* CABLES DIRECTLY BURIED OUT OF PADMOUNT TRANSFORMERS OR PEDESTALS.

\*\*\* CABLES IN NON-VENTED CABLE GUARDS OR IN CONDUITS LONGER THAN 2 METRES.

*SUPERCEDES ORIGINAL SEALED BY E. WIEBE ON 94-07-03*

APPROVED  ORIGINAL DRAWING SEALED BY J.J.D. RINGASH 16-03-30	REVISIONS		MANITOBA HYDRO DISTRIBUTION STANDARDS					
	17-01	5	REVISED TABLE		<b>STANDARD UNDERGROUND SECONDARY CABLE DATA</b>			
	16-03	4	ADDED 1000 kcmil ALUM. COND., REVISED DATE, RESEALED					
08-12	3	ADDED COLD & HEAT SHRINK CAPS AND LINEAL MASS TO TABLE						
DRAWN C.A.	CHECKED J.R.	DATE 16-03		<b>CD 210-15</b>			SHT 0001 OF 1	REV 05

1-04431-DA-58041-0009

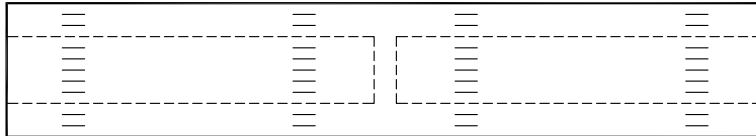

- FOR SPLICING SECONDARY ALUMINUM/COPPER CONDUCTORS.
- NOT SUITABLE FOR USE ON PRIMARY CONDUCTORS.
- COMPLETE WITH BARRIER TO PREVENT MOISTURE MIGRATION.
- FILLED WITH SYNTHETIC INHIBITOR.
- STAMPED WITH CONDUCTOR AND DIE SIZE.
- **COMPRESSION TOOL DIE MUST MATCH DIE NUMBER STAMPED ON CONNECTOR.**
- WIRE BRUSH ALL CONDUCTORS PRIOR TO INSTALLING CONNECTOR.

**\* UNDERGROUND SECONDARY CABLE COMPRESSION CONNECTORS**

CONDUCTOR SIZE		STORES CODE	TOOL (DIES)	
FROM	TO		PREFERRED	ALTERNATE
#4	#4	74 27 64	Y35 (UCSA 22)	** MD6 (WCSA 22, BG)
1/0	#2	74 27 30		
1/0	1/0	74 27 65		
4/0	1/0	74 27 67	Y35 (UCSA 24)	** MD6 (WCSA 24, 249)
4/0	4/0	74 27 68		
350	4/0	74 27 78	Y35 (UCSA 28)	---
350	350	74 27 72		
750	500	74 27 27	Y46/ADPT (UCSA 30)	---

\* FOR CONNECTING INSULATED ALUMINUM TO BARE COPPER, REFER TO DRAWING CD215-13.

\*\* ROTATE MD6 TOOL 180° AFTER EVERY CRIMP.

APPROVED		REVISIONS		MANITOBA HYDRO DISTRIBUTION STANDARDS					
ORIGINAL DRAWING SEALED BY E.H. WIEBE 94-07-03				<b>UNDERGROUND SECONDARY CABLE COMPRESSION CONNECTORS</b>					
		95-09	2					350-4/0 CONNECTOR ADDED	
		95-01	1					NOTE ON MD6 TOOL ADDED	
DRAWN W.B./CAD	CHECKED G.W.	DATE 93-07		<b>CD 210-21</b>		SHT 0001 OF 1	REV 02		

- COMPRESSION TOOL DIE MUST MATCH DIE NUMBER STAMPED ON CONNECTOR.
- WIRE BRUSH CONDUCTORS PRIOR TO INSTALLING COMPRESSION CONNECTORS.

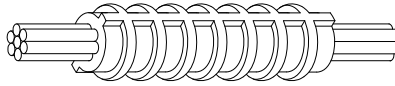

<b>UNDERGROUND NEUTRAL COMPRESSION CONNECTORS</b>			
CONDUCTOR SIZE		STORES CODE	TOOL (DIES)
FROM	TO		
#4	#4	74 32 04	MD6 (162)
#2	#2	74 32 02	MD6 (163)
2/0	2/0	74 31 26	MD6 (166)
4/0	4/0	74 31 28	Y35 (168)
350	350	74 32 31	Y35 (267)

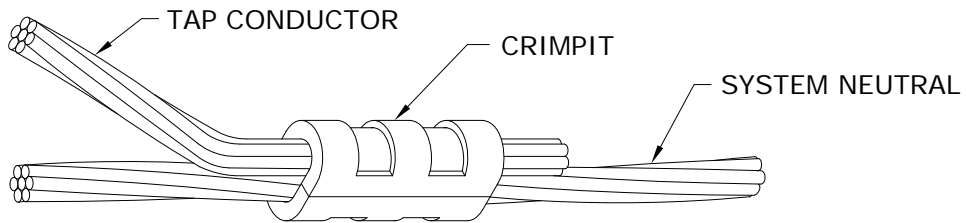

<b>UNDERGROUND NEUTRAL "C" TYPE (CRIMPIT) COMPRESSION CONNECTORS</b>			
<b>* (FOR USE ON COPPER CONDUCTORS ONLY)</b>			
CONDUCTOR SIZE		STORES CODE	TOOL (DIES)
RUN	TAP		
#6 - #4	#6	74 41 10	MD6 (BG)
#4	#4	74 40 90	MD6 (BG)
#2	#4	74 40 80	MD6 (WC)
#2	#2	74 40 70	MD6 (WC)
1/0 - 2/0	1/0 - 2/0	74 41 12	Y35 (UO)
3/0 - 250	#6 - 2/0	74 41 15	Y35 (U997)
3/0 - 250	3/0 - 250	74 41 16	Y35 (U997)
300 - 500	#6 - 2/0	54 23 60	Y46 (P1011)
300 - 500	3/0 - 250	18 30 74	Y46 (P1011)

\* FOR CONNECTING BARE COPPER TO INSULATED ALUMINUM, REFER TO DRAWING CD215-13.

APPROVED  ORIGINAL DRAWING SEALED BY E.H. WIEBE 94-07-03	REVISIONS		MANITOBA HYDRO DISTRIBUTION STANDARDS							
	10-12	2	ADDED CONNECTOR							
	95-01	1	NOTES REARRANGED							
	93-07	0	CONNECTORS ADDED, FORMERLY CD210-8							
DRAWN W.B./CAD			CHECKED K.C.H.		DATE 93-07		<b>CD 210-24</b>		SHT	REV
									0001 OF 1	02

THERE ARE THREE METHODS FOR SPLICING 600 VOLT UNDERGROUND SECONDARY CABLES:

- 1) HEAT SHRINK INSULATING TUBING SPLICE
- 2) PRE-STRETCHED INSULATING TUBING SPLICE
- 3) TAPED SPLICE

750 kcmil AND 1000 kcmil CABLES, USED IN CONJUNCTION WITH 3-PHASE COMMERCIAL SERVICES, SHALL NOT BE SPLICED, EXCEPT FOR EMERGENCY REPAIRS.

**GENERAL INSTRUCTIONS:**

1. a) FOR 1/0 AND 4/0 TRIPLEX CABLES:

- REMOVE ANY DAMAGED OR CONTAMINATED PORTIONS OF CABLE.
- TRAIN CABLES INTO FINAL POSITION (DO NOT SNAKE IN TRENCH).
- CUT CABLES SQUARE AND BUTT ENDS.
- STAGGER SPLICES.
- PROCEED TO STEP 2.

b) FOR #4 CONCENTRIC NEUTRAL CABLE:

- REMOVE ANY DAMAGED OR CONTAMINATED PORTIONS OF CABLE.
- TRAIN CABLES INTO FINAL POSITION WITH ENDS OVERLAPPING C/L BY 150mm.
- TIGHTLY TWIST CONCENTRIC NEUTRAL WIRES INTO A BUNDLED CONDUCTOR FOR APPROXIMATELY 250mm AND TEMPORARILY FOLD BACK.
- CUT OFF APPROXIMATELY 100mm OF CABLE FROM EACH END.
- PROCEED TO STEP 2.

2. SELECT APPROPRIATE SLEEVE AND DIE ACCORDING TO DRAWING CD210-21.

3. SELECT SPLICING METHOD (FOR CORRECT MANUFACTURED SPLICES, REFER TO TABLE ON SHEET 2 of 3).

NOTE:

FOR SPLICING BARE COPPER NEUTRAL WIRE TO INSULATED ALUMINUM CABLE, REFER TO DRAWING CD215-13.

4. REMOVE JACKET AND INSULATION FROM CABLES AS PER FIGURE 1 OR FOLLOW MANUFACTURERS INSTRUCTIONS; BE CAREFUL NOT TO NICK INSULATION OR CONDUCTOR.

5. CLEAN CONDUCTOR WITH WIRE BRUSH. INSTALL CONNECTOR.

NOTE:

EXCEPT FOR TAPED SPLICE, SLIDE TUBING OVER ONE CONDUCTOR BEFORE INSTALLING CONNECTOR.

*SUPERCEDES ORIGINAL SEALED BY E. WIEBE ON 94-07-03*

APPROVED		REVISIONS		MANITOBA HYDRO DISTRIBUTION STANDARDS	
ORIGINAL DRAWING SEALED BY J.J.D. RINGASH 17-10-11	17-10	3	REMOVED RAYCHEM RAYVOLVE SPLICING, RESEALED	<b>SPLICES FOR UNDERGROUND SECONDARY CABLES</b>	
	96-05	2	NOTES REVISED, SHEET 3 ADDED		
	95-01	1	NOTES 3, 7 & TABLE ADDED		
DRAWN C.A.	CHECKED K.S.	DATE 17-10	<b>CD 215-12</b>		SHT 0001 OF 3
					REV 03



6. CLEAN JACKET (50mm), INSULATION, AND CONNECTOR WITH AN APPROVED CLEANING SOLVENT (S.C.# 43 11 95).

7. COMPLETE SELECTED SPLICE (AS CHOSEN IN STEP 3).

NOTE:

TO COMPLETE #4 CONCENTRIC NEUTRAL SPLICE, PROCEED TO STEP 8.

8. FOR #4 CONCENTRIC NEUTRAL CABLE: (CONT'D)

- a) APPLY 1 LAYER OF 1/4 STRETCHED 50mm WIDE RUBBER MASTIC TAPE (S.C.#78 55 28) OVER CENTRE OF COMPLETED SPLICE.
- b) TRAIN TWISTED CONCENTRIC NEUTRAL WIRE (STEP 1b) INTO FINAL POSITION ALLOWING ADEQUATE CLEARANCE FOR MD6 PRESS.
- c) PLACE "C" TYPE COMPRESSION CONNECTOR OVER TWISTED WIRES AND CRIMP. REFER TO DRAWING CD210-24.
- d) TRIM OFF PROTRUDING WIRES AND COMPRESS WITH PLIERS ELIMINATING ANY SHARP ENDS.
- e) APPLY A 100mm STRIP OF 50mm WIDE RUBBER MASTIC TAPE OVER CONNECTOR AND PROTRUDING WIRES.

NOTE:

SHINY SIDE AGAINST CONNECTOR AND THE 100mm LENGTH PARALLEL TO CONNECTOR AND WIRE.

- f) FORM TAPED CONCENTRIC NEUTRAL CONNECTION AND WIRES AROUND SPLICE AND CABLE.
- g) APPLY 2 LAYERS 3/4 STRETCHED COLD WEATHER VINYL TAPE (S.C.#78 55 98) OVER TAPED CONCENTRIC NEUTRAL CONNECTION AND SPLICE, APPROXIMATELY 50mm WIDE.

MANUFACTURED SPLICES FOR SECONDARY CABLES		
CONDUCTOR SIZE	TYPE OF SPLICE	STORES CODE
#4 TO 1/0	PRESTRETCHED	85 13 10
4/0 TO 350	PRESTRETCHED	85 13 40
	HEAT SHRINK	85 13 50

*SUPERCEDES ORIGINAL SEALED BY E. WIEBE ON 94-07-03*

APPROVED		REVISIONS		MANITOBA HYDRO DISTRIBUTION STANDARDS			
ORIGINAL DRAWING SEALED BY J.J.D. RINGASH 17-10-11	17-08	4	REVISED TABLE, RESEALED	<b>SPLICES FOR UNDERGROUND SECONDARY CABLES</b>			
	15-02	3	REMOVED RAYVOLVE SPLICE FROM TABLE				
	08-03	2	REVISED TABLE AND NOTE 6				
DRAWN C.A.	CHECKED K.S.	DATE 17-08	<b>CD 215-12</b>		SHT 0002 OF 3	REV 04	

**FOR TAPED SPLICE**

TAPES SHALL ONLY BE APPLIED DIRECTLY FROM ROLL ONTO SPLICE, HALF LAPPED AND STRETCHED TO 3/4 OF THEIR ORIGINAL WIDTH.

1. APPLY 3 LAYERS OF SELF-AMALGAMATING ETHYLENE PROPYLENE RUBBER (E.P.R.) TAPE (S.C.#78 55 23) AS PER FIGURE 2.
2. APPLY 2 LAYERS OF COLD WEATHER VINYL TAPE (S.C.#78 55 98) AS PER FIGURE 2.

OR

APPLY 3 LAYERS OF SELF-AMALGAMATING HIGH TEMPERATURE SILICONE TAPE (S.C.#03 74 67). VINYL TAPE IS NOT REQUIRED.

**NOTE:**  
DIMENSIONS SHOWN ARE MILLIMETRES.

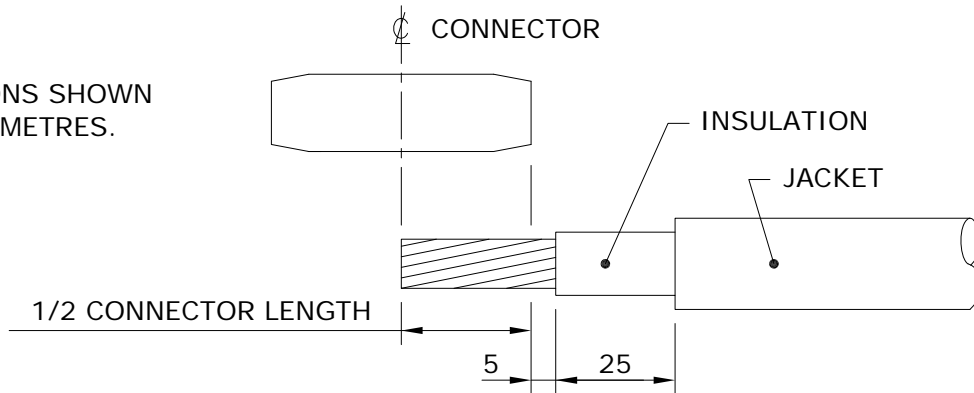

**FIGURE 1**

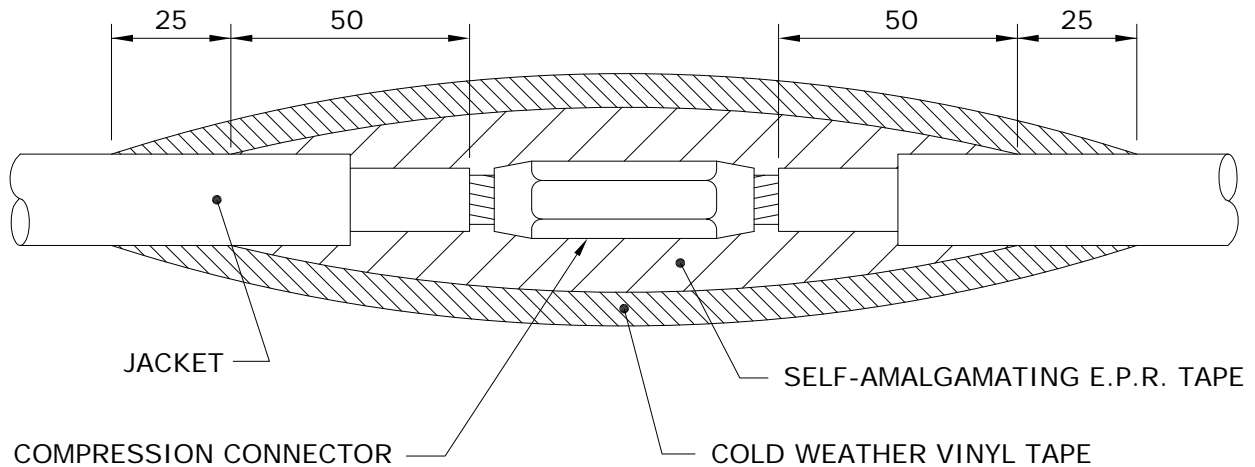

**FIGURE 2**

*SUPERCEDES ORIGINAL SEALED BY E. WIEBE ON 97-01-08*

APPROVED		REVISIONS		MANITOBA HYDRO DISTRIBUTION STANDARDS		
ORIGINAL DRAWING SEALED BY J.J.D. RINGASH 17-10-11				<b>SPLICES FOR UNDERGROUND SECONDARY CABLES</b>		
		17-10	2			RESEALED
		10-12	1			REVISED COMPRESSION CONNECTOR AND NOTE 2
DRAWN C.A.	CHECKED K.S.	DATE 17-10	<b>CD 215-12</b>		SHT 0003 OF 3	
					REV 02	

**CABLE PREPARATION:**

- ① REMOVE PVC (POLYVINYL CHLORIDE) JACKET TO DIMENSION "A" PLUS 25mm.
- ② REMOVE POLYETHYLENE INSULATION TO DIMENSION "A" PLUS 5mm.  
USE ABRASIVE TAPE (SC. 78 50 04) ON ALL CONNECTON SURFACES.
- ③ INSTALL ROD CONNECTOR AS PER TABLE BELOW AND FIGURE 1.

CONDUCTOR SIZE	* ROD CONNECTOR STORES CODE No.	PRESS	DIE
1/0 ALUMINUM	74 27 62	Y35/MD6	CSA 22
4/0 ALUMINUM	74 27 69	Y35/MD6	CSA 24

\* ROD IS FACTORY CRIMPED INTO CONNECTOR

- ④ CONNECT BARE COPPER STRANDED WIRE TO ROD CONNECTOR AS PER TABLE BELOW. USE ABRASIVE TAPE ON ALL CONNECTON SURFACES.

CONDUCTOR SIZE	CONNECTOR STORES CODE No.	PRESS	DIE
COPPER ROD TO #4 COPPER STRANDED	74 40 90	Y35/MD6	WBG
COPPER ROD TO #2 COPPER STRANDED	74 40 70	MD6	WC

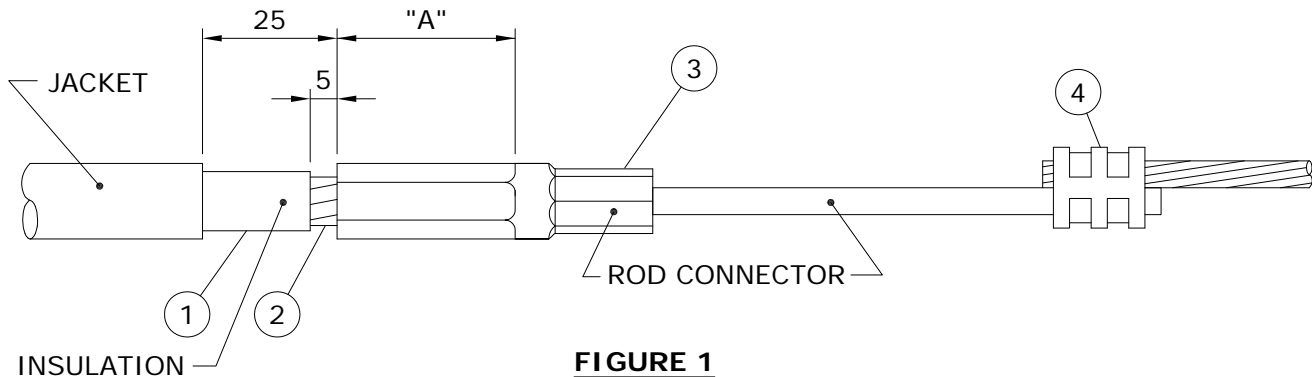

**FIGURE 1**

**NOTE:** DIMENSIONS SHOWN ARE MILLIMETRES.

APPROVED	REVISIONS		MANITOBA HYDRO DISTRIBUTION STANDARDS		
ORIGINAL DRAWING SEALED BY E.H. WIEBE 94-07-03			<b>SPLICING SECONDARY NEUTRAL (BARE COPPER TO INSULATED ALUMINUM)</b>		
	08-11	2			REVISED TABLE AND COMPRESSION CONNECTOR
	94-10	1			ROD CONNECTOR ADDED
DRAWN W.B./CAD	CHECKED B.H./K.C.H.	DATE 94-06	<b>CD 215-13</b>		
			SHT 0001 OF 2	REV 02	

**TAPING:**

- 5 ABRASE ROD PORTION OF ROD CONNECTOR WITH ABRASIVE TAPE AS SHOWN IN FIGURE 2.
- 6 CLEAN JACKET, INSULATION & ROD CONNECTOR WITH AN APPROVED CLEANING SOLVENT (S.C.# 43 11 95).
- 7 CUT ONE PIECE OF RUBBER MASTIC TAPE (S.C. 78 55 28) INTO EITHER A 50mm WIDE x 75mm LONG STRIP FOR 1/0 CONNECTOR OR A 50mm WIDE x 125mm LONG STRIP FOR 4/0 CONNECTOR.
- 8 APPLY THE PRECUT STRIP OF RUBBER MASTIC TAPE 1/4 STRETCHED, SHINING SIDE DOWN ONTO THE ROD AS SHOWN IN FIGURE 2.
- 9 APPLY 2 LAYERS OF HALF LAPPED 3/4 STRETCHED SELF AMALGAMATING ETHYLENE PROPYLENE RUBBER TAPE (S.C.# 78 55 23) AS SHOWN IN FIGURE 2.
- 10 APPLY 2 LAYERS OF HALF LAPPED 3/4 STRETCHED COLD WEATHER VINYL TAPE (S.C.# 78 55 98) AS SHOWN IN FIGURE 2.

**NOTE:**

WHEN INSTALLING A MANUFACTURED SPLICE INCLUDE STEPS 5 THRU 8 WITH THE MANUFACTURERS INSTRUCTIONS. THIS WILL PROVIDE THE PROPER INSULATION AND MOISTURE SEAL.

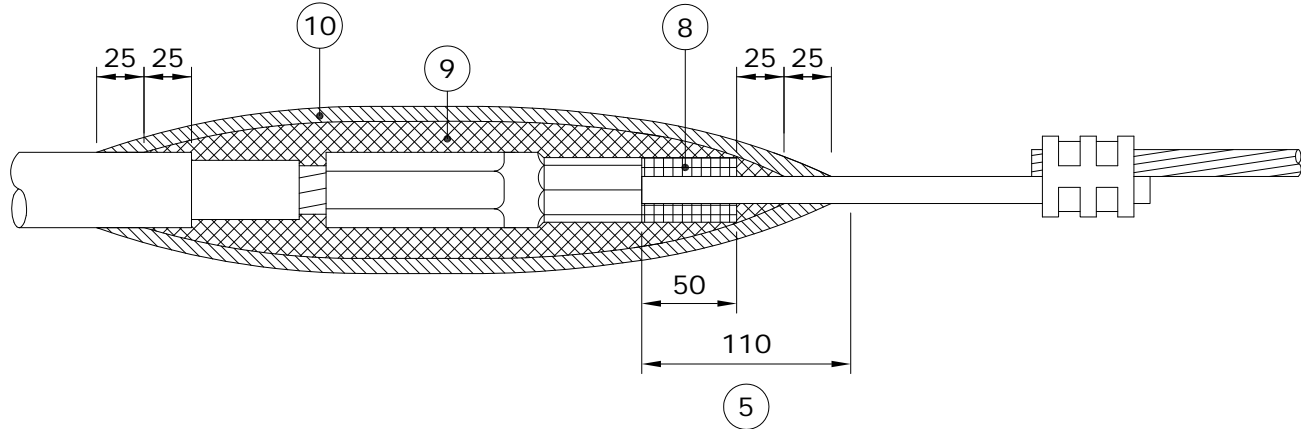

**FIGURE 2**

**NOTE:** DIMENSIONS SHOWN ARE MILLIMETRES.

APPROVED		REVISIONS		MANITOBA HYDRO DISTRIBUTION STANDARDS		
ORIGINAL DRAWING SEALED BY E.H. WIEBE 94-07-03				<b>SPLICING SECONDARY NEUTRAL (BARE COPPER TO INSULATED ALUMINUM)</b>		
		08-11	2			REVISED NOTE 6 & COMPRESSION CONNECTOR
		94-10	1			TAPING PROCEDURE REVISED
DRAWN W.B./CAD	CHECKED K.C.H.	DATE 94-06	<b>CD 215-13</b>		SHT 0002 OF 2	
					REV 02	

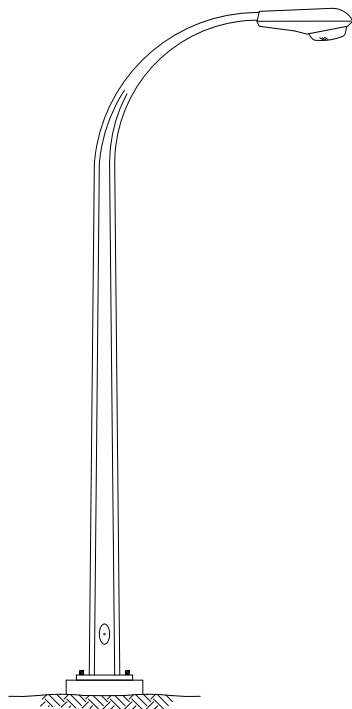

**DAVIT BM**  
(BASE MOUNTED)

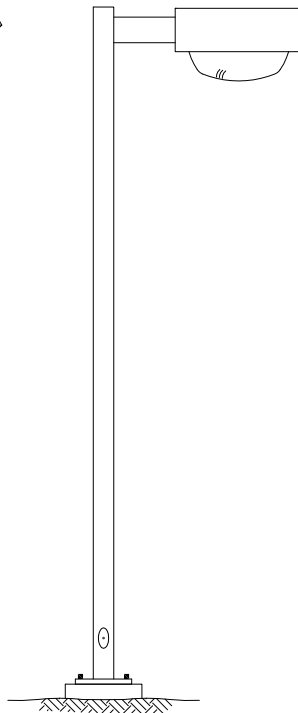

**SQUARE BM**  
(BASE MOUNTED)

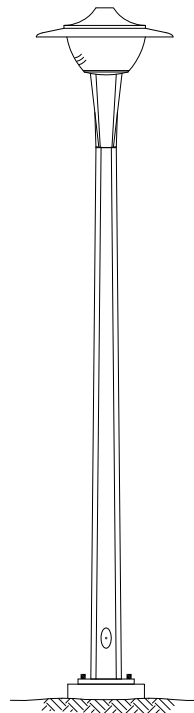

**POST-TOP  
CONTEMPORARY BM**  
(BASE MOUNTED)

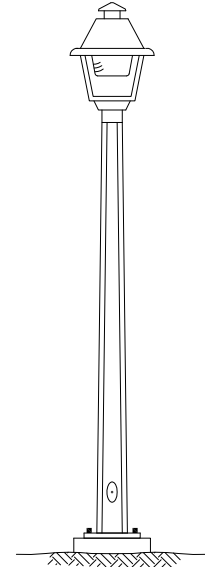

**POST-TOP  
COLONIAL BM**  
(BASE MOUNTED)

POLE TYPE	COLOUR	MOUNTING HEIGHT m (ft)	ARM REACH m	BOLT SQUARE mm	BOLT CIRCLE mm	STORES CODE NO.	CABLE LENGTH m **
DAVIT BM	GALVANIZED	7.7 (25)	1.8	179	254	75 42 26	11
DAVIT BM *	GALVANIZED	9.1 (30)	2.4	197	279	75 43 30	13
DAVIT BM	GALVANIZED	10.7 (35)	3.0	206	292	75 44 36	15
DAVIT BM	GALVANIZED	13.7 (45)	3.0	243	343	75 46 45	18
SQUARE BM	DARK BRONZE	6.1 (20)	0.5	179	254	75 42 20	8
SQUARE BM	DARK BRONZE	10.7 (35)	0.5	206	292	75 45 30	14
POST-TOP BM CONTEMPORARY	GALVANIZED	6.1 (20)	N/A	179	254	75 41 22	7
POST-TOP BM COLONIAL	GALVANIZED	4.7 (15)	N/A	179	254	75 41 15	6

**NOTES:**

\* FOR REPLACEMENT PURPOSES; NOT TO BE USED FOR NEW INSTALLATIONS.

\*\* LENGTH OF 2 CONDUCTORS #12 CABLE REQUIRED PER POLE.

APPROVED		REVISIONS		MANITOBA HYDRO DISTRIBUTION STANDARDS			
ORIGINAL DRAWING SEALED BY E.H. WIEBE 89-04-28	13-01	3	ADDED CONTEMPORARY AND COLONIAL POLES	<b>STANDARD STEEL STREET LIGHT POLES</b>			
	12-05	2	REVISED DRAWING & CANCELLED SHEETS 2 AND 3				
	94-09	1	DELETED ORNAMENTAL				
DRAWN W.B./CAD	CHECKED L.D./D.O.	DATE 88-06	<b>CD 300-1</b>		SHT	REV	
					0001 OF 1	03	

## 7.7 - 10.7 STREET LIGHT POLES

**NOTES:**

1. FOR FUTURE ACCESS TO LOWER PORTION OF PLASTIC PIPE, LOCATE "V" GROOVE SIDE OF BASE TO ROADWAY PROVIDED THAT:
  - a) A MIN. HORIZONTAL SEPARATION OF 350mm IS MAINTAINED TO ANY PAVED SURFACE OR STRUCTURE; OR
  - b) IF LESS THAN 350mm, ROTATE BASE 90°
2. ROUTE UNDERGROUND CABLES DIRECTLY INTO PLASTIC PIPE.
3. IN BACKFILL AREA, ENCASE UNDERGROUND CABLES IN A 75mm RADIUS ENVELOPE OF EXCAVATED MATERIAL OR SAND TO PROTECT CABLES. DO NOT BACKFILL WITH EXCAVATED MATERIAL OR SAND MORE THAN 1/6 OF THE WAY AROUND BASE.
4. SEE CD300-9 FOR ANCHOR ROD TIGHTENING METHOD.
5. DIMENSIONS SHOWN ARE MILLIMETRES.

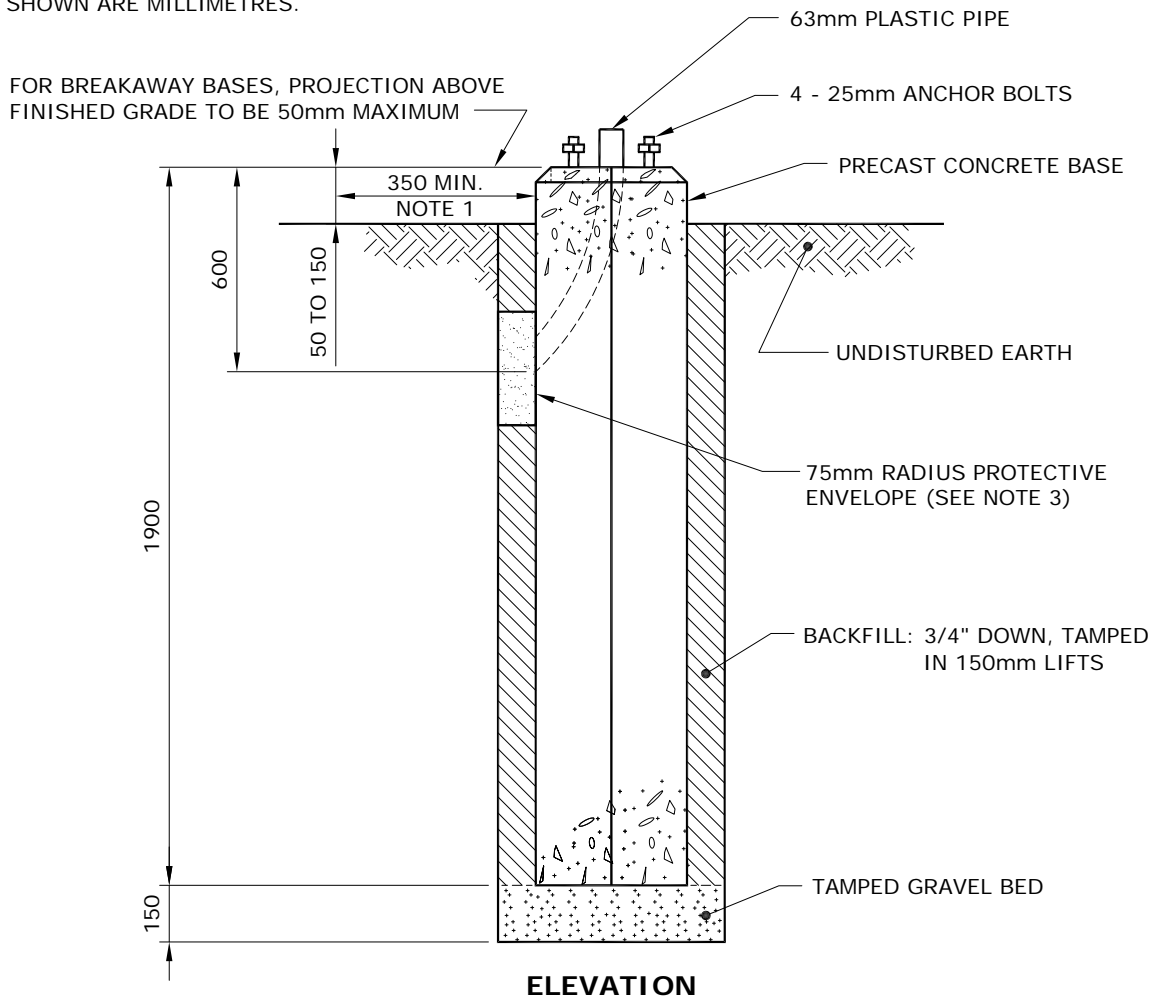
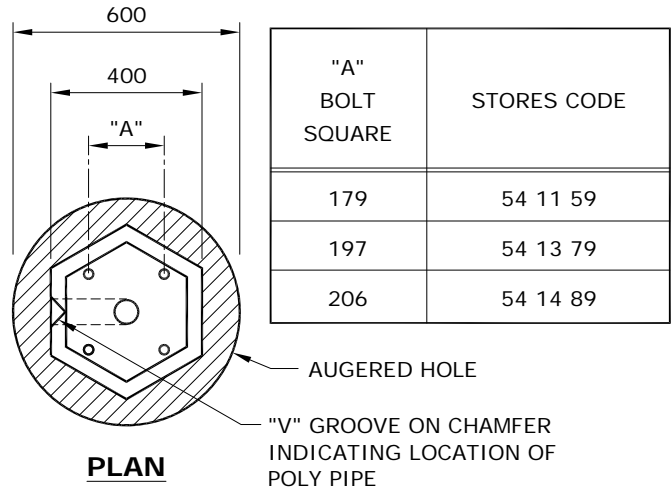

APPROVED	REVISIONS			MANITOBA HYDRO DISTRIBUTION STANDARDS			
ORIGINAL DRAWING SEALED BY E.H. WIEBE 89-04-29	10-08	3	CHANGED BACKFILL NOTES, AND ADDED SHEET 3	<b>INSTALLATION OF PRECAST CONCRETE BASE</b>			
	99-05	2	SHEET 2 of 2 ADDED, 7.7 - 10.7 STREET LIGHT ADDED				
	96-10	1	V-GROOVE LOCATION, POLY PIPE SIZE NOTES CHANGED				
DRAWN W.B./CAD	CHECKED L.D./K.C.H.	DATE 88-06	<b>CD 300-6</b>			SHT 0001 OF 3	REV 03

### 13.7 STREET LIGHT POLE

**NOTES:**

1. FOR FUTURE ACCESS TO LOWER PORTION OF PLASTIC PIPE, LOCATE "V" GROOVE SIDE OF BASE TO ROADWAY PROVIDED THAT:
  - a) A MIN. HORIZONTAL SEPARATION OF 350mm IS MAINTAINED TO ANY PAVED SURFACE OR STRUCTURE; OR
  - b) IF LESS THAN 350mm, ROTATE BASE 90°
2. ROUTE UNDERGROUND CABLES DIRECTLY INTO PLASTIC PIPE.
3. IN BACKFILL AREA, ENCASE UNDERGROUND CABLES IN A 75mm RADIUS ENVELOPE OF EXCAVATED MATERIAL OR SAND TO PROTECT CABLES. DO NOT BACKFILL WITH EXCAVATED MATERIAL OR SAND MORE THAN 1/6 OF THE WAY AROUND BASE.
4. SEE CD300-9 FOR ANCHOR ROD TIGHTENING METHOD.
5. DIMENSIONS SHOWN ARE MILLIMETRES.

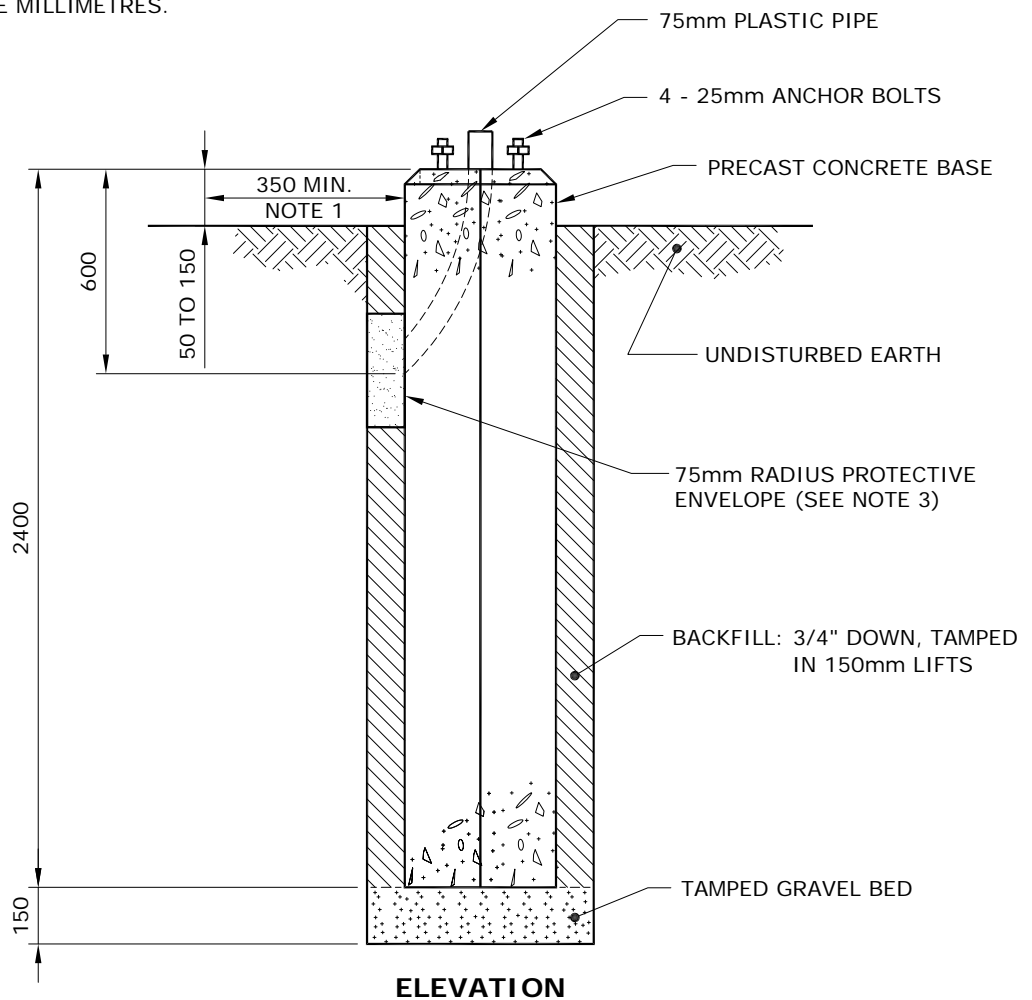
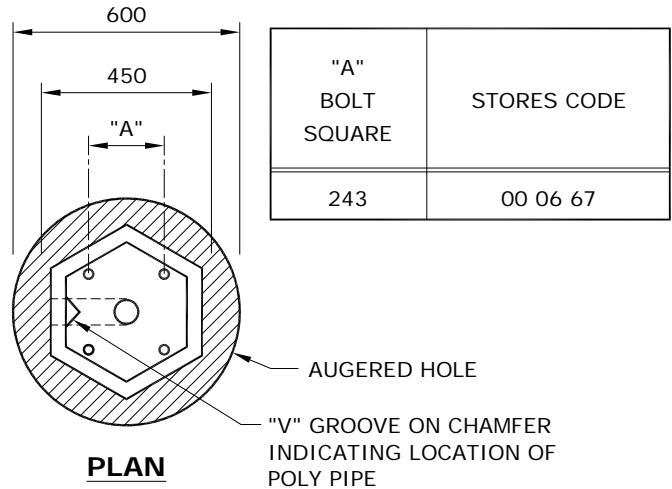

APPROVED	REVISIONS	MANITOBA HYDRO DISTRIBUTION STANDARDS	
ORIGINAL DRAWING SEALED BY E.H. WIEBE 89-04-29		<b>INSTALLATION OF PRECAST CONCRETE BASE</b>	
	10-08   1   CHANGED BACKFILL NOTES, AND ADDED SHEET 3		
DRAWN R.L.B./CAD	CHECKED L.D./K.C.H.	DATE 99-05	<b>CD 300-6</b>
			SHT 0002 OF 3
			REV 01

TO DEVELOP THE REQUIRED TENSION ON ANCHOR RODS, THE TURN-OF-NUT METHOD IS USED.

### TURN-OF-NUT

1. ENSURE ALL ANCHOR RODS AND NUTS ARE FREE OF DEBRIS AND THAT THE ANCHOR RODS ARE LUBRICATED.
2. PLACE POLE ONTO CONCRETE PILE, INSTALL WASHERS AND NUTS AND TIGHTEN UNTIL DEVELOPING A SNUG-TIGHTENED CONNECTION.

**SNUG-TIGHTENED:** THE TIGHTNESS THAT IS ATTAINED AFTER A FEW IMPACTS OF AN IMPACT WRENCH OR THE FULL FORCE OF A WORKER USING AN ORDINARY ONE FOOT LONG WRENCH.

3. TIGHTENING OF THE BOLTS MUST BE PERFORMED IN A MANNER THAT BRINGS THE FAYING SURFACES UP "EVENLY" AS PER THE STAR PATTERN TIGHTENING SEQUENCE.

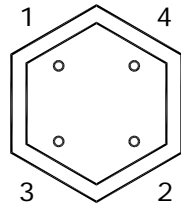

FOUR ANCHOR BOLT PATTERN  
(13.7m AND BELOW)

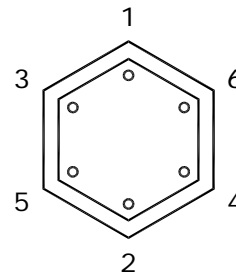

SIX ANCHOR BOLT PATTERN  
(16.8m AND 19.8m)

4. ENSURE THE POLE IS PLUMB AND ADD LEVELING SHIMS IF REQUIRED. SNUG-TIGHTEN THE ANCHOR BOLTS AGAIN.
5. BEVELED WASHERS ARE REQUIRED IF THE NUT CANNOT BE BROUGHT INTO FIRM CONTACT WITH THE BASE PLATE.
6. MARK THE REFERENCE LOCATION OF THE NUT AFTER SNUG-TIGHTENING THE PLUMB POLE.
7. FINAL TIGHTENING OF NUTS IS PERFORMED IN INCREMENTS AS PER THE STAR PATTERN, WITH A MINIMUM OF TWO FULL TIGHTENING CYCLES. PROPER TENSIONING IS ACHIEVED WHEN THE NUT IS ROTATED 1/3 OF A TURN BEYOND SNUG-TIGHT. THE TOLERANCE FOR THIS IS PLUS 20°.

APPROVED	REVISIONS		MANITOBA HYDRO DISTRIBUTION STANDARDS	
ORIGINAL DRAWING SEALED BY K.C. HAMILTON 10-08-13			<b>METHOD FOR ANCHOR ROD TIGHTENING</b>	
DRAWN C.A.	CHECKED L.D.	DATE 10-08	<b>CD 300-9</b>	
			SHT 0001 OF 1	REV 00



THE FOLLOWING INSTALLATION INSTRUCTIONS ARE APPLICABLE TO NEW OR EXISTING BREAKAWAY BASE INSTALLATIONS ON CONCRETE BASES.

**PROCEDURE:**

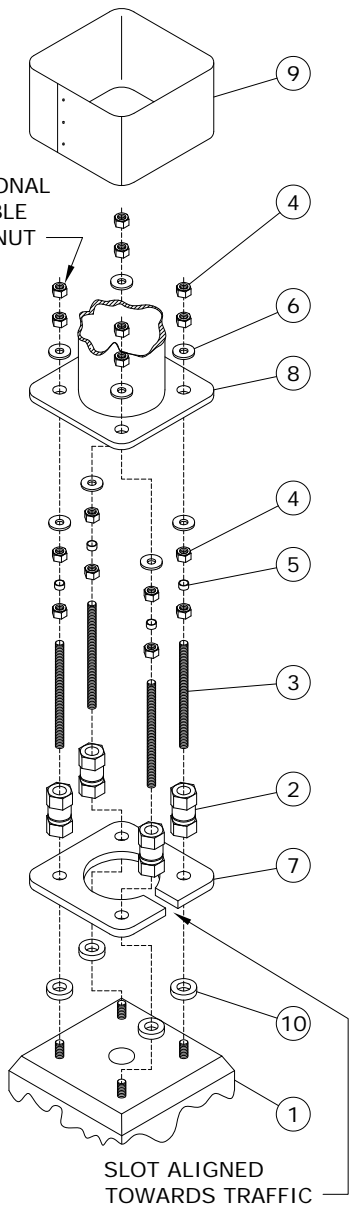

1. CLEAN THE TOP SURFACE OF THE CONCRETE BASE AND ENSURE SURFACE IS FLAT AND LEVEL WITH NO SPALLING OR OTHER SURFACE CONDITIONS THAT MAY AFFECT THE PERFORMANCE OF THE COUPLERS.
  2. THE PREFERRED MAXIMUM HEIGHT ABOVE LEVEL GRADE TO THE BASE OF THE COUPLER IS 50mm OR LESS. THIS PROVIDES THE RECOMMENDED CLEARANCE IN THE EVENT OF A COLLISION WITH THE STRUCTURE.
  3. MEASURE THE HEIGHT OF THE THREADED ANCHOR BOLTS ABOVE THE REACTION PLATE AND VERIFY THIS MEASUREMENT IS BETWEEN 1 1/4" AND 1 5/8".
  4. IF THE EXPOSED LENGTH OF THE ANCHOR BOLT IS GREATER THAN THE RECOMMENDED LENGTH, OPTIONAL SPACERS MAY BE USED (ITEM 10).
  5. IT IS RECOMMENDED THAT THE THREADED ANCHOR BOLT-COUPLER CONNECTION BE COATED WITH RUST-INHIBITING GREASE. THIS WILL FACILITATE REMOVAL OF THE COUPLER WHEN IT IS NECESSARY. A SUITABLE PRODUCT FOR THIS APPLICATION IS ARCAN 1, A WHITE, WATER RESISTANT GREASE MARKETED BY IMPERIAL OIL LTD.
  6. THREAD THE COUPLER ASSEMBLY ON EACH ANCHOR BOLT (IF THE COUPLER ASSEMBLY UPPER STUD BECOMES LOOSE AS A RESULT OF HANDLING, ENSURE THAT THE STUD IS ENGAGED AT LEAST 38mm, BUT NOT MORE THAN 44mm IN THE COUPLER BEFORE LOCKING WITH THE LOCK NUT.)
  7. SNUG UP EACH COUPLER AGAINST THE CONCRETE BASE. TIGHTEN EACH COUPLER ALTERNATELY AND INCREMENTALLY, BY MEANS OF A WRENCH OR A PIPE WRENCH ON THE BOTTOM HEX OF THE COUPLER. USE THE TURN-OF-NUT METHOD AS PER CD300-9.
- NOTE: TIGHTENING THE COUPLER ON THE TOP HEX MAY WEAKEN THE COUPLER AT THE MACHINED GROOVE AND MAKE THE COUPLER UNUSEABLE.**
8. BRING THE LEVELING NUTS (AND HENCE, THE LOWER WASHERS) INTO A LEVEL PLANE AS DESIRED MAKING CERTAIN THAT AT LEAST ONE PLASTIC SPACER REMAINS IN CONTACT WITH ITS LEVELING NUT AND ITS LOCK NUT.
  9. PLACE THE POLE BASE OVER THE PROTRUDING STUDS, AND SECURE THE POLE WITH THE UPPER WASHERS AND RETAINING NUTS.
  10. WITH THE POLE IN THE REQUIRED VERTICAL ORIENTATION, AND BEFORE FINAL TIGHTENING, ENSURE THAT ALL LEVELING NUTS, RETAINING NUTS AND UPPER AND LOWER WASHERS ARE MADE SNUG AGAINST THE POLE BASE PLATE.
  11. TIGHTEN THE RETAINING NUTS WITH THE TURN-OF-NUT METHOD AS PER CD300-9.
  12. MAKE THE NECESSARY WIRING CONNECTIONS, AND INSTALL THE PROTECTIVE SHROUD.

SUPERCEDES ORIGINAL SEALED BY E. WIEBE ON 89-04-28

APPROVED		REVISIONS		MANITOBA HYDRO DISTRIBUTION STANDARDS	
ORIGINAL DRAWING SEALED BY D.R. ORR 16-06-27	16-06	4	CORRECTED TYPO, RESEALED	<b>BREAKAWAY BASE INSTALLATION</b>	
	10-08	3	UPDATED STANDARD, REVISED TITLE, AND ADDED SHEET 2		
	07-06	2	REVISED NOTE 4 AND ADDED NOTE 5		
DRAWN C.A.	CHECKED L.D.	DATE 16-06	<b>CD 300-10</b>		SHT 0001 OF 2
					REV 04

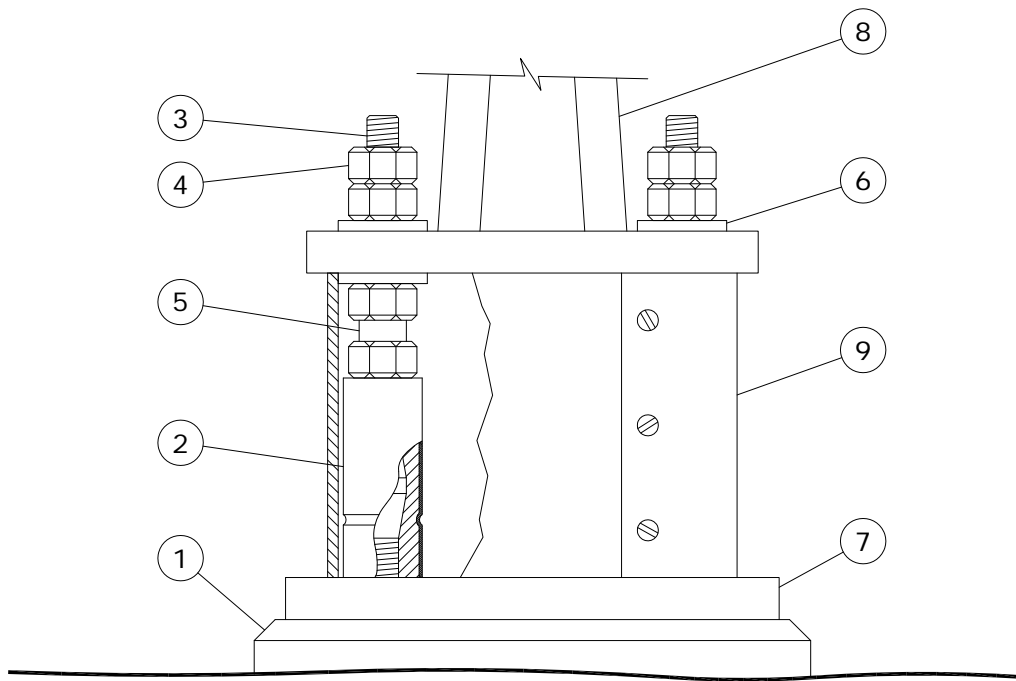

**BILL OF MATERIAL**

ITEM NO.	DESCRIPTION	QUANTITY
1	CONCRETE BASE	1
2	COUPLING	4
3	1" - 8 UNC GALV. STUD	4
4	1" - 8 UNC GALV. HEAVY HEX NUT	16
5	SPACER	4
6	1" GALV. FLAT WASHER	8
7	REACTION PLATE	1
8	POLE	1
9	SHROUD ASSEMBLY	1
10	GALV. SHIM	4

APPROVED  ORIGINAL DRAWING SEALED BY K.C. HAMILTON 10-08-13	REVISIONS		MANITOBA HYDRO DISTRIBUTION STANDARDS		
			<b>BREAKAWAY BASE INSTALLATION</b>		
DRAWN C.A.	CHECKED L.D.	DATE 10-08	<b>CD 300-10</b>	SHT 0002 OF 2	REV 00

### STREET LIGHT POLES \*

POLE TYPE	MOUNTING HEIGHT m (ft)	MATERIAL	WEIGHT *, ** kg (±10%)
STRAIGHT SHAFT	10.7 (35)	ALUMINUM	91
DAVIT (DB)	11.3 (37)	CONCRETE	998
DAVIT (DB)	13.7 (45)	CONCRETE	1087
POST TOP (DB)	6.1 (20)	CONCRETE	544
DAVIT	7.7 (25)	STEEL	97
DAVIT	9.1 (30)	STEEL	125
DAVIT	10.7 (35)	STEEL	157
DAVIT	13.7 (45)	STEEL	219
DAVIT	16.8 (55)	STEEL	330
DAVIT	19.8 (65)	STEEL	428
POST TOP	4.7 (15)	STEEL	53
POST TOP	6.1 (20)	STEEL	68
STRAIGHT SHAFT	7.7 (25)	STEEL	90
STRAIGHT SHAFT	9.1 (30)	STEEL	113
STRAIGHT SHAFT	10.7 (35)	STEEL	172
STRAIGHT SHAFT	13.7 (45)	STEEL	220
STRAIGHT SHAFT	16.8 (55)	STEEL	388
STRAIGHT SHAFT	19.8 (65)	STEEL	557

\* ALL POLES ARE BASE MOUNTED EXCEPT CONCRETE.

\*\* WEIGHTS DO NOT INCLUDE ARMS OR LUMINAIRES.

\*\*\* WEIGHTS GATHERED FROM MANUFACTURER'S DRAWING.

### BASES

TYPE	WEIGHT kg (±10%)
179	605
197	605
206	605
243	970
418	2151

APPROVED	REVISIONS	MANITOBA HYDRO DISTRIBUTION STANDARDS		
ORIGINAL DRAWING SEALED BY D.R. ORR 16-01-14		<b>RIGGING WEIGHTS OF STREET LIGHT COMPONENTS</b>		
	18-04	1	UPDATED TABLES	
DRAWN C.A.	CHECKED J.R.	DATE 16-01	<b>CD 300-18</b>	
			SHT 0001 OF 1	REV 01

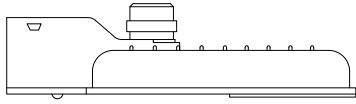

**LED ROADWAY LUMINAIRE**

LED ROADWAY LUMINAIRES			
LUMINAIRE WATTAGE (NOMINAL)	REPLACES (HPS)	CIIC	
		GREY	BLACK
40 W LED	70 W HPS	05 15 44	05 15 71
60 W LED	100 W HPS	05 15 45	05 15 73
90 W LED	150 W HPS	05 15 47	05 15 74
150 W LED	250 W HPS	05 15 48	05 15 75
240 W LED	400 W HPS	05 15 49	05 15 76

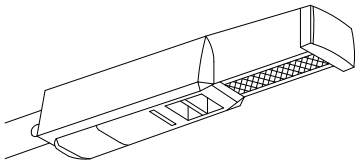

**LED LANE LUMINAIRE**

LED LANE LUMINAIRES		
LUMINAIRE WATTAGE (NOMINAL)	REPLACES (HPS)	CIIC
50 W LED	70 W HPS	05 15 50

LED LANE LUMINAIRES ARE AVAILABLE WITH GREY COATING ONLY.

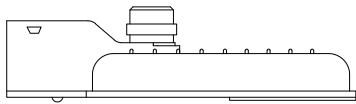

**LED DUSK-TO-DAWN LUMINAIRE**

LED DUSK-TO-DAWN (AREA) LUMINAIRES		
LUMINAIRE WATTAGE (NOMINAL)	REPLACES (HPS)	CIIC
60 W LED	100 W HPS	05 15 51
90 W LED	150 W HPS	05 15 52

LED DUSK-TO-DAWN LUMINAIRES ARE AVAILABLE WITH GREY COATING ONLY.

- ALL LED LUMINAIRES AUTOMATICALLY ADJUST FOR EITHER A 120V OR 240V SUPPLY.
- ALL LED LUMINAIRES COME WITH A PHOTOCCELL RECEPTACLE.

APPROVED		REVISIONS		MANITOBA HYDRO DISTRIBUTION STANDARDS	
ORIGINAL DRAWING SEALED BY D.R. ORR 15-02-11		16-12 1 REVISED NOTES		<b>STANDARD LED LUMINAIRES</b>	
		DATE 15-02		<b>CD 300-24</b>	
				SHT 0001 OF 2	
				REV 01	

**TRENCH AND PLOW-IN LOCATION**

GENERALLY, THE TRENCH LOCATION WILL DICTATE THE LOCATION OF THE LIGHT STANDARDS. CONTACT SHALL BE MADE WITH THE GOVERNING MUNICIPAL AUTHORITY TO DETERMINE THEIR SET BACK REQUIREMENTS. CONTACT SHALL ALSO BE MADE WITH THE CITY OF WINNIPEG UNDERGROUND STRUCTURES OR THE INDIVIDUAL UTILITIES OUTSIDE WINNIPEG TO DETERMINE THE EXISTENCE AND EXACT LOCATION OF OTHER UTILITIES PLANT. THIS INFORMATION WILL BE INCLUDED ON THE WORK ORDER PLANS.

**DEPTH OF BURIAL**

THE CABLE SHALL BE BURIED BELOW THE SURFACE OF THE EARTH A MINIMUM OF 600mm IN SODDED AREAS AND 1000mm IN ROADWAYS.

**TRENCH DETAILS**

TYPICAL TRENCH DETAILS FOR SODDED AREAS ARE SHOWN BELOW, FOR TRENCH DETAILS UNDER ROADWAYS REFER TO DRAWING CD205-14. SEE NOTES ON SHEET 2 of 2.

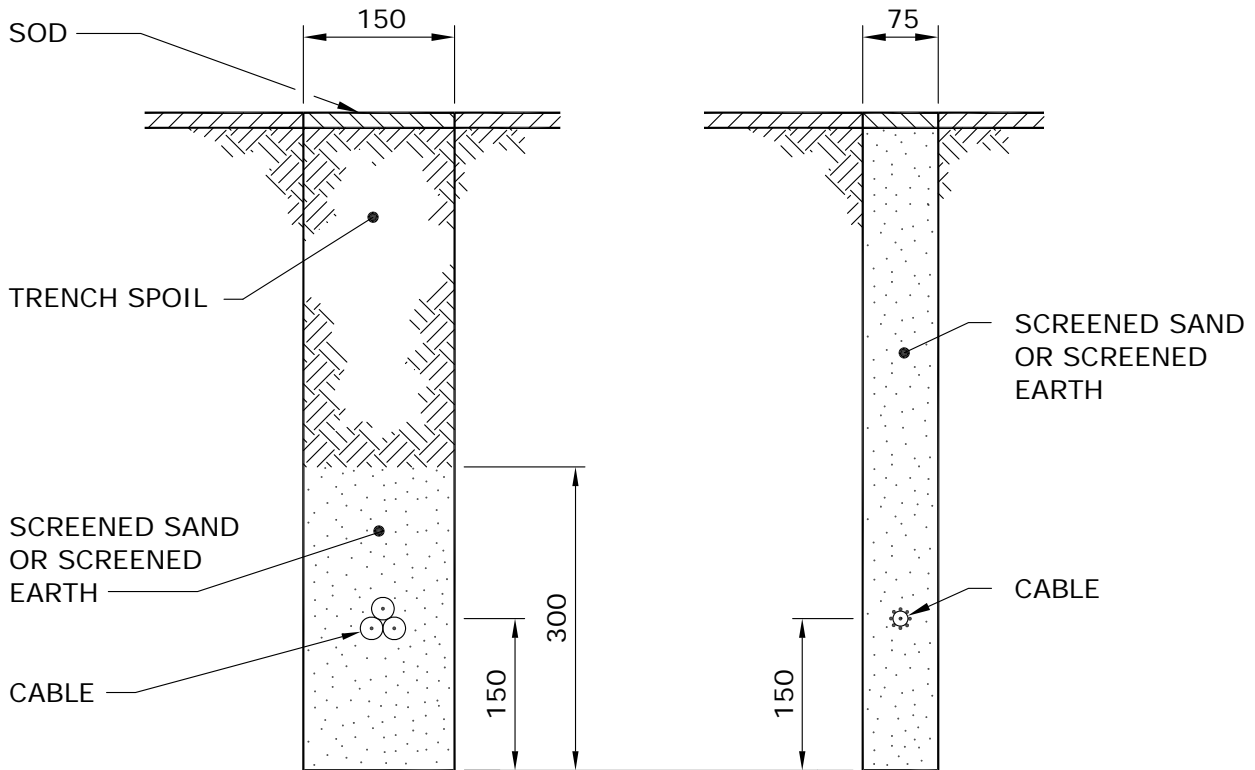

**NOTE:** DIMENSIONS SHOWN ARE MILLIMETRES.

APPROVED		REVISIONS		MANITOBA HYDRO DISTRIBUTION STANDARDS	
ORIGINAL DRAWING SEALED BY E.H. WIEBE 89-04-28	96-01	3	ROADWAY DEPTH ADDED	<b>PLOWING AND TRENCHING DETAILS FOR UNDERGROUND STREET LIGHT CIRCUITS</b>	
	95-09	2	BURIAL DEPTH NOTE ADDED		
	94-04	1	COMBINED WITH DWG. CD305-2		
DRAWN W.B./CAD	CHECKED	DATE 88-07	<b>CD 305-1</b>		SHT 0001 OF 2
					REV 03

NOTES:

1. FOR TYPICAL TRENCH DETAIL INSTALLATION UNDER ROADWAYS, REFER TO DRAWING CD205-14.
2. THESE ARE ALTERNATIVE TRENCH WIDTHS. A 75mm TRENCH IS PREFERABLE WHERE THE GROUND IS FIRM AND A CLEAN CUT CAN BE MADE. A 150mm TRENCH IS PREFERABLE WHERE THE GROUND IS TOO LOOSE TO MAINTAIN A FIRM TRENCH WALL.
3. THE CABLES INDICATED IN THE VIEWS CAN BE USED IN EITHER TRENCH.
4. THE 75mm TRENCH SHALL BE BACKFILLED WITH SCREENED SAND OR SCREENED EARTH.
5. THE 150mm TRENCH SHALL BE BACKFILLED WITH THE TRENCH SPOIL IF IT IS FREE FROM ROCKS OR DEBRIS. IF THE TRENCH SPOIL CONTAINS ROCKS OR DEBRIS, SCREENED SAND OR SCREENED EARTH SHALL BE INSTALLED AS SHOWN.

APPROVED		REVISIONS		MANITOBA HYDRO DISTRIBUTION STANDARDS		
ORIGINAL DRAWING SEALED BY E.H. WIEBE 89-04-28				<b>PLOWING AND TRENCHING DETAILS FOR UNDERGROUND STREET LIGHT CIRCUITS</b>		
		96-01	2			NOTES REVISED
		94-04	1			COMBINED WITH DWG. CD305-2
DRAWN W.B./CAD	CHECKED	DATE 88-07	<b>CD 305-1</b>		SHT 0002 OF 2	
					REV 02	

1. **GENERAL**

PLOWED-IN CABLES SHALL BE PULLED TO 1m ABOVE GRADE AT EACH STREET LIGHT STANDARD LOCATION. THE CABLE DEPTH SHALL BE MAINTAINED AT THE 600mm PLOW DEPTH AS CLOSE AS POSSIBLE TO THE STREET LIGHT STANDARD LOCATION BEFORE RAISING THE PLOW. THE PLOW SHALL BE RETURNED TO THE 600mm PLOW DEPTH AS CLOSE AS POSSIBLE TO THE CENTRE LINE OF THE STREET LIGHT STANDARD LOCATION.

CABLES LAID IN TRENCHES SHALL HAVE SUFFICIENT SLACK TO ALLOW FOR FUTURE MOVEMENT OR SETTLING OF THE TRENCH FLOOR. CABLES SHALL PROJECT 1m ABOVE GRADE AT EACH LOCATION.

2. **USE OF POLYETHYLENE PIPE**

2.1 WHERE CABLES ARE INSTALLED UNDER EXISTING PAVEMENT, POLYETHYLENE PIPE SHALL BE INSTALLED TO PROTECT THE CABLES IF THE HOLE IS AUGERED OR PUSHED THROUGH MATERIAL CONTAINING ROCKS, STONES, OR DEBRIS.

2.2 AT THE JUNCTION OF THE MAIN TRENCH AND THE STREET OR DRIVEWAY CROSSING, THE BOTTOM OF THE TRENCH SHALL BE BACKFILLED AND TAMPED TO THE LEVEL OF THE POLYETHYLENE PIPES TO PREVENT SHARP BENDS IN THE CABLE AND TRAPPING OF WATER IN THE PIPE.

3. **SPLICES - UNDERGROUND CABLES**

UNDERGROUND STREET LIGHT CABLES (i.e. #4 ALUMINUM CONCENTRIC NEUTRAL CABLE AND 1/0 TRIPLEXED CABLE) ARE TO BE SPLICED USING AN APPROPRIATE COMPRESSION SLEEVE (SEE DRAWING CD210-21) AND THE SPLICE IS TO BE INSULATED USING ONE OF THE FOLLOWING METHODS:

- 1) RAYCHEM RAYVOLVE SPLICE
- 2) PRE-STRETCHED INSULATING TUBING SPLICE
- 3) HEAT SHRINK INSULATING TUBING SPLICE
- 4) TAPED SPLICE

FOR COMPLETE INSTRUCTIONS REGARDING THE ABOVE SPLICES, REFER TO DRAWING CD215-12.

APPROVED		REVISIONS		MANITOBA HYDRO DISTRIBUTION STANDARDS			
ORIGINAL DRAWING SEALED BY E.H. WIEBE 89-04-28		94-04 1		DWG. REFERENCE CHANGED			
DRAWN W.B./CAD	CHECKED W.C.	DATE 88-07	<b>CD 310-1</b>		SHT	REV	
					0001 OF 2	01	

4. **CABLE END CAPS**

STREET LIGHT CABLES WHICH ARE NOT GOING TO BE SPLICED OR TERMINATED IMMEDIATELY FOLLOWING INSTALLATION SHALL BE CUT SQUARE AND SEALED WITH AN END CAP. REFER TO DRAWING CD215-21 FOR DETAILS.

5. **GROUNDING OF STREET LIGHT STANDARDS**

5.1 ALL STREET LIGHT STANDARDS SHALL BE GROUNDED BY CONNECTING THE NEUTRAL TO THE GROUND STUD INSIDE THE STANDARD. REFER TO DRAWING CD310-4 FOR DETAILS.

5.2 A GROUND ROD SHALL BE INSTALLED AND CONNECTED TO THE GROUND STUD AT THE LAST STANDARD ON THE STREET LIGHT CIRCUIT.

APPROVED		REVISIONS		MANITOBA HYDRO DISTRIBUTION STANDARDS	
ORIGINAL DRAWING SEALED BY E.H. WIEBE 89-04-28		94-04   1   DWG. REFERENCE CHANGED		<b>INSTALLATION OF STREET LIGHT CABLES</b>	
DRAWN W.B./CAD	CHECKED W.C.	DATE 88-07	<b>CD 310-1</b>		SHT 0002 OF 2
				REV 01	



**RAYCHEM GELCAP CIIC# 04-29-36**

**GENERAL INSTRUCTIONS:**

1. REMOVE 16mm (5/8") OF INSULATION AND CLEAN EXPOSED ENDS.

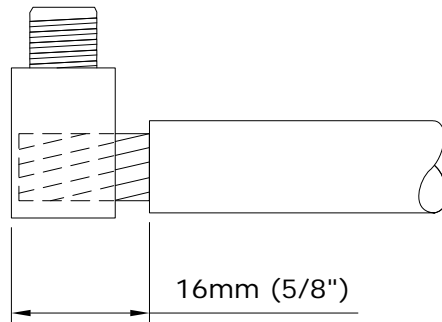

2. INSERT CONDUCTORS INTO CORRECT HOLES AND TORQUE AS SHOWN:

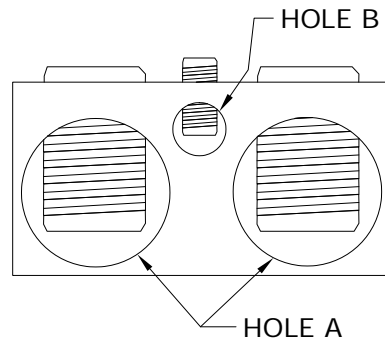

HOLE A		HOLE B	
WIRE RANGE	RECOMMENDED TORQUE VALUES	WIRE RANGE	RECOMMENDED TORQUE VALUES
#14 - 2/0 • STREET LIGHT CIRCUIT CABLES • GROUNDING CONNECTIONS • CONCENTRIC NEUTRAL • FUSE HOLDER WIRE	14 - 20 N-m (120 - 180 in-lbs)	#14 - #6 • LAMP LEADS	14 - 17 N-m (120 - 150 in-lbs)

APPROVED	REVISIONS		MANITOBA HYDRO DISTRIBUTION STANDARDS		
ORIGINAL DRAWING SEALED BY J.J.D. RINGASH 18-03-05			<b>RAYCHEM GELCAP SPLICE</b>		
DRAWN	CHECKED	DATE	<b>CD 310-3</b>	SHT	REV
C.A.	L.D.	17-11		0001 OF 3	00

- INSTALL CLAMP ON CAP. ENSURE THE TWO PINS ON THE BOTTOM EDGE OF THE CLAMP MATE WITH THE HOLES OF THE CAP AS SHOWN IN FIGURE 1a BELOW.

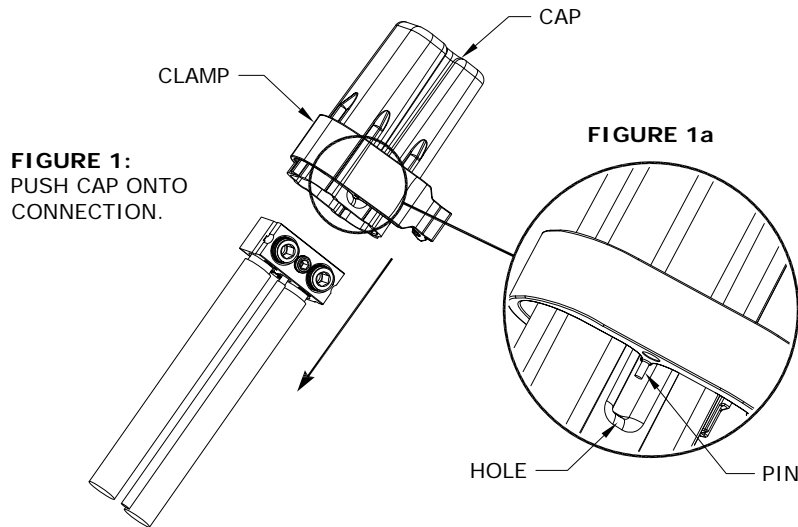

- INSTALL CAP BY HOLDING ALL WIRES AND PUSHING THE CAP OVER THE CONNECTION ASSEMBLY UNTIL IT GOES NO FURTHER AS SHOWN IN FIGURE 1 ABOVE.
- SNAP CLAMP CLOSED. IF NECESSARY, USE PLIERS TO SNAP CLAMP CLOSED AS SHOWN IN FIGURE 2 BELOW.

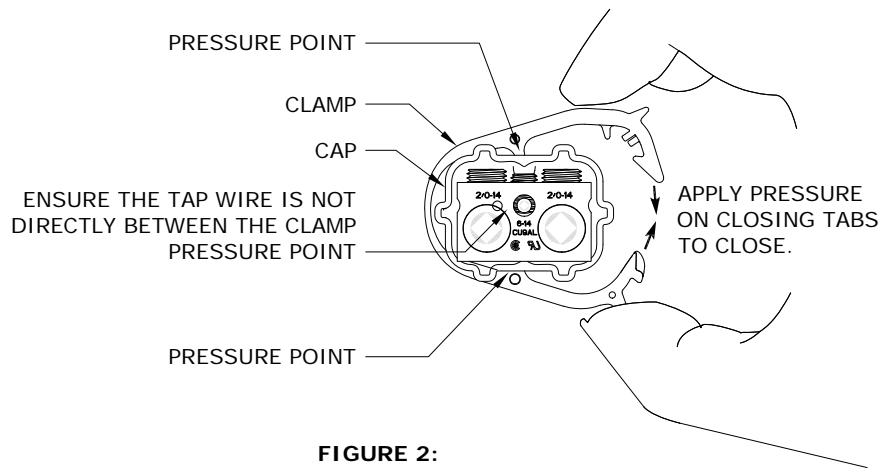

APPROVED		REVISIONS		MANITOBA HYDRO DISTRIBUTION STANDARDS	
ORIGINAL DRAWING SEALED BY J.J.D. RINGASH 18-03-05				<b>RAYCHEM GELCAP SPLICE</b>	
DRAWN C.A.	CHECKED L.D.	DATE 17-11	<b>CD 310-3</b>		
			SHT 0002 OF 3		REV 00

6. INSPECT THE INSTALLATION BY GENTLY PULLING ON THE CAP ENSURING IT IS LOCKED IN PLACE AND COVERS CONNECTOR AND BARE CONDUCTOR. THERE SHOULD BE NO EXPOSED METAL. ENSURE TAP CABLE IS NOT CAUGHT BETWEEN PRESSURE POINTS OF CLAMP. INSTALLATION IS COMPLETE.

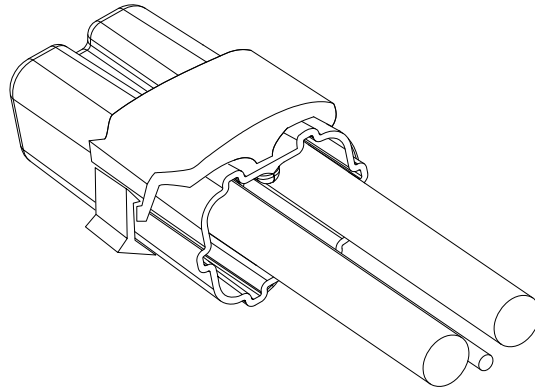

7. TO REMOVE, INSERT SCREWDRIVER BETWEEN THE CLOSING TABS AND TWIST TO OPEN THE CLAMP. REMOVE CAP SLOWLY FROM CONNECTION ALLOWING GEL TO REMAIN IN CAP.

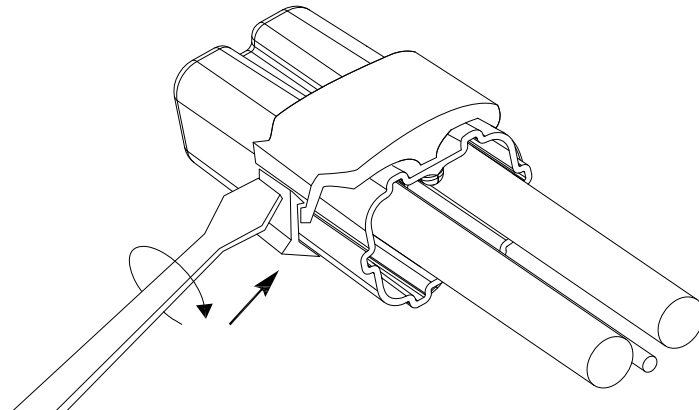

APPROVED		REVISIONS		MANITOBA HYDRO DISTRIBUTION STANDARDS	
ORIGINAL DRAWING SEALED BY J.J.D. RINGASH 18-03-05				<b>RAYCHEM GELCAP SPLICE</b>	
DRAWN C.A.	CHECKED L.D.	DATE 17-11	<b>CD 310-3</b>		
					SHT 0003 OF 3

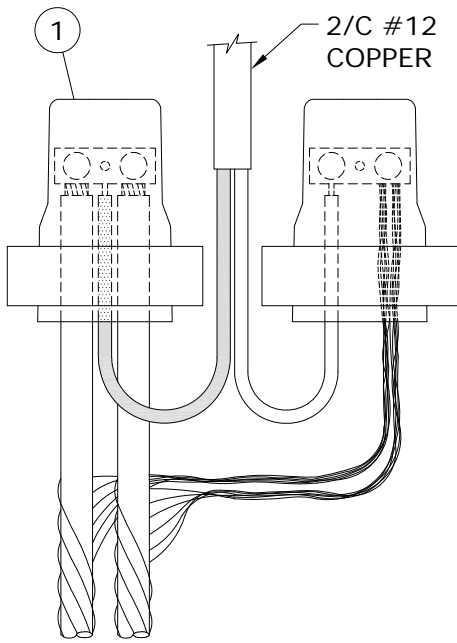

**No. 4 ALUMINUM C/N CABLE  
(TYPICAL FEED THROUGH)**

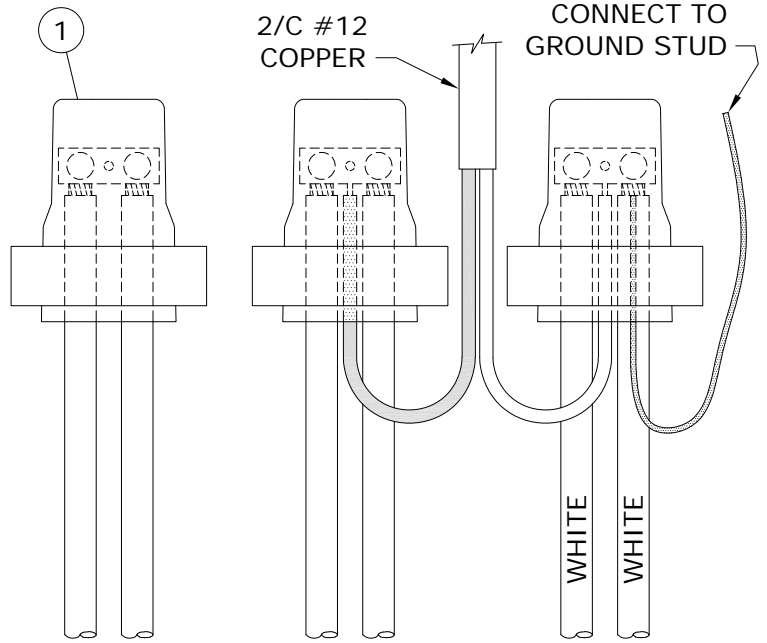

**1/0 ALUMINUM TRIPLEX CABLE  
(TYPICAL FEED THROUGH)**

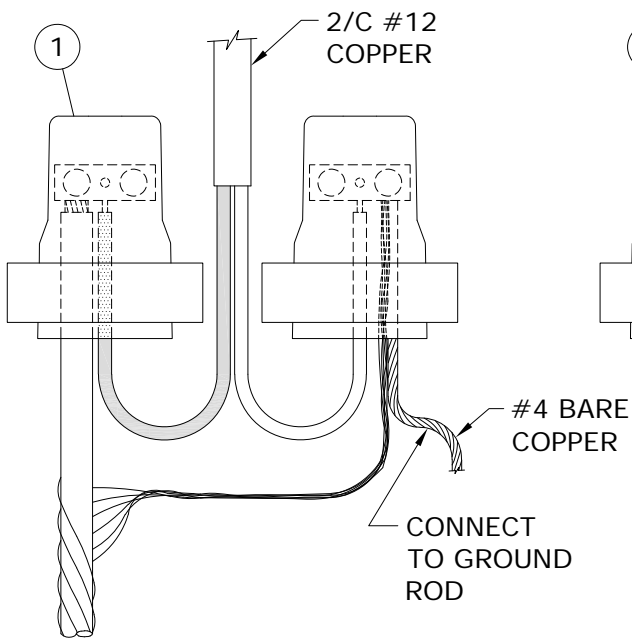

**No. 4 ALUMINUM C/N CABLE  
(TYPICAL END OF CIRCUIT)**

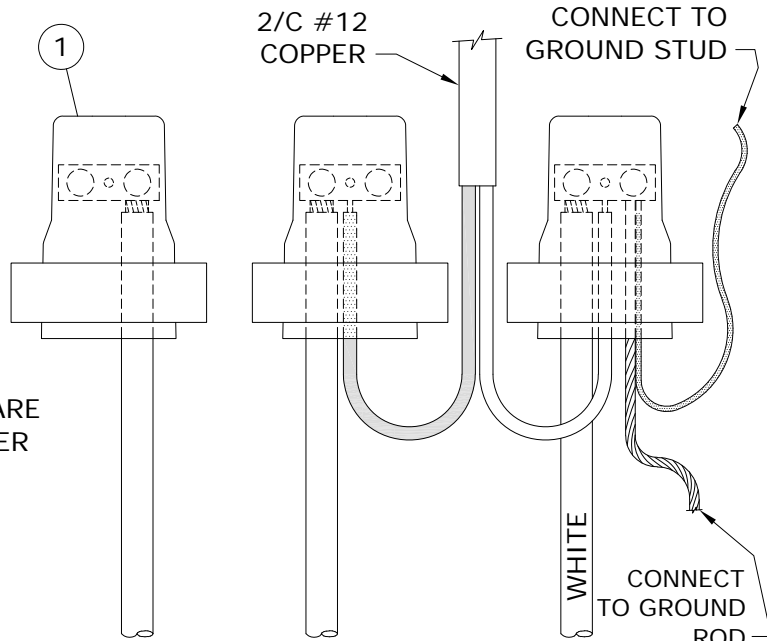

**1/0 ALUMINUM TRIPLEX CABLE  
(TYPICAL END OF CABLE)**

SUPERCEDES ORIGINAL SEALED BY E. WIEBE ON 89-04-28

APPROVED		REVISIONS		MANITOBA HYDRO DISTRIBUTION STANDARDS	
ORIGINAL DRAWING SEALED BY J.J.D. RINGASH 18-05-11	18-04	2	ADDED SHT 3 & 4, MOVED PREVIOUS INFO FROM SHT1 TO SHT3, ADDED NEW GELCAP, DWG, REVISED TITLE, RESEALED	<b>CONNECTION DETAIL IN STREET LIGHT STANDARD</b>	
	94-04	1	CONN. REVISED DUE TO INSUL. NEUTRAL		
DRAWN C.A.	CHECKED L.D.	DATE 18-04		<b>CD 310-4</b>	

BILL OF MATERIAL			
ITEM No.	DESCRIPTION	STORES CODE No.	
		FOR USE WITH #4 AL. C/N	FOR USE WITH 1/0 AL. TRIPLEX
1	GEL CAP	04-29-36 (2 REQUIRED)	04-29-36 (3 REQUIRED)

NOTES:

1. LEAVE SUFFICIENT SLACK ON CONDUCTORS TO ALLOW REMOVAL FROM HANDHOLE FOR MAINTENANCE.
2. REFER TO DRAWING CD310-3 FOR GEL CAP INSTALLATION INSTRUCTIONS.

*SUPERCEDES ORIGINAL SEALED BY E. WIEBE ON 94-07-03*

APPROVED		REVISIONS		MANITOBA HYDRO DISTRIBUTION STANDARDS	
ORIGINAL DRAWING SEALED BY J.J.D. RINGASH 18-05-11		18-04 1 ADDED SHT 3 & 4, MOVED PREVIOUS INFO FROM SHT2 TO SHT4, ADDED NEW BOM WITH GELCAP, REVISED TITLE, RESEALED		<b>CONNECTION DETAIL IN STREET LIGHT STANDARD</b>	
C.A.		L.D.		DATE	
				18-04	
				<b>CD 310-4</b>	
				SHT	
				0002 OF 4	
				REV	
				01	

1-04431-DA-56200-0002

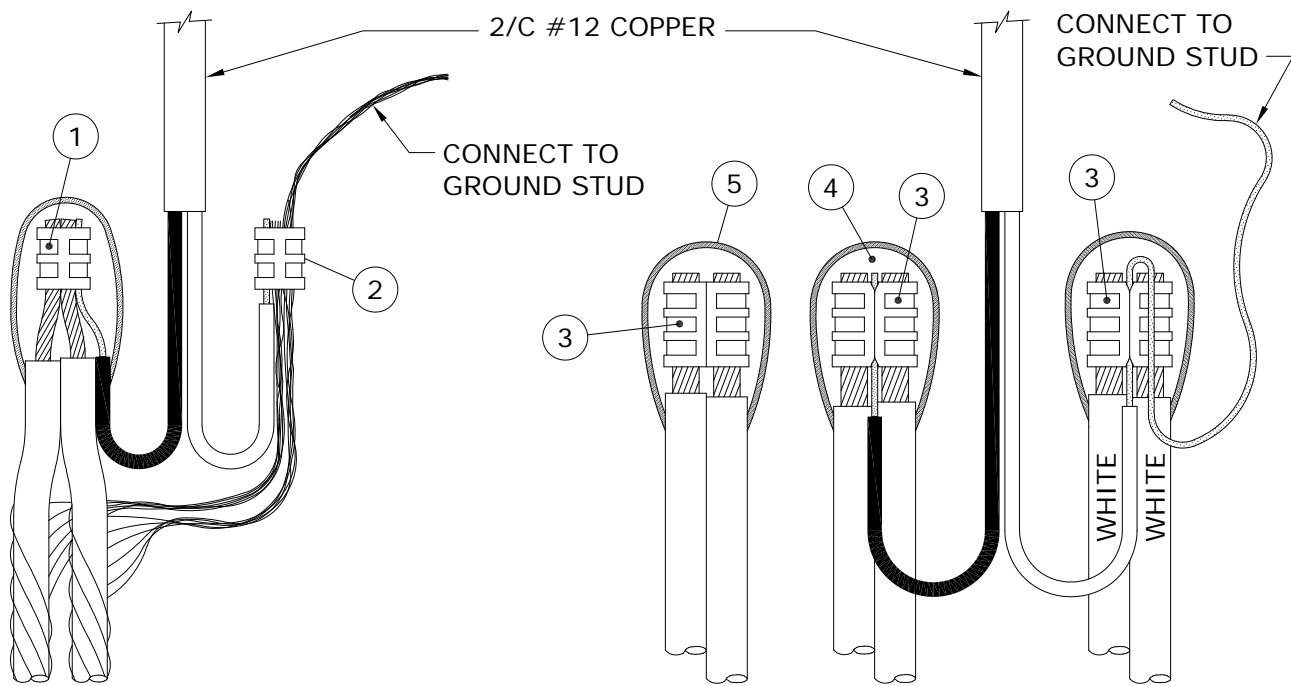

**No. 4 ALUMINUM C/N CABLE  
(TYPICAL FEED THROUGH)**

**1/0 ALUMINUM TRIPLEX CABLE  
(TYPICAL FEED THROUGH)**

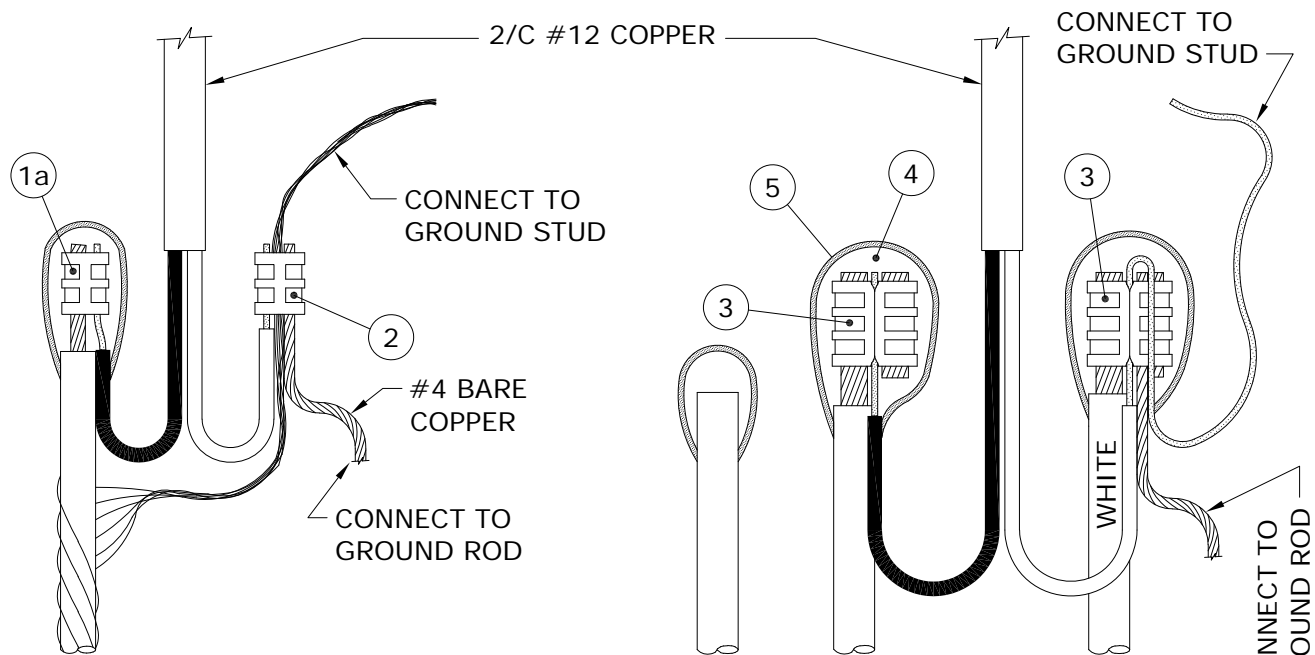

**No. 4 ALUMINUM C/N CABLE  
(TYPICAL END OF CIRCUIT)**

**1/0 ALUMINUM TRIPLEX CABLE  
(TYPICAL END OF CIRCUIT)**

APPROVED		REVISIONS		MANITOBA HYDRO DISTRIBUTION STANDARDS			
ORIGINAL DRAWING SEALED BY J.J.D. RINGASH 18-05-11		18-04 0 MOVED FROM SHEET 1		<b>CONNECTION DETAIL IN STREET LIGHT STANDARD</b>			
						DRAWN C.A.	
<b>CD 310-4</b>				SHT		REV	
				0003 OF 4		00	

**BILL OF MATERIAL**

ITEM No.	DESCRIPTION	STORES CODE No.		QUANTITY
		FOR USE WITH #4 AL. C/N	FOR USE WITH 1/0 AL. TRIPLEX	
1	'C' TYPE AL. COMPRESSION TAP	74-41-30	---	1
1a	'H' TYPE AL. COMPRESSION TAP	74-40-10	---	1 *
2	'C' TYPE CU. COMPRESSION TAP	74-40-90	---	1
3	'H' TYPE AL. COMPRESSION TAP	---	74-40-60	3 **
4	TAPE, SELF-AMALGAMATING EPR	78-55-23	78-55-23	1/4 ROLL
5	TAPE, COLD WEATHER VINYL	78-55-98	78-55-98	1/4 ROLL

- \* FOR END OF CIRCUIT WHEN USING ONLY ONE CABLE.
- \*\* AT END OF CIRCUIT, QUANTITY MAY BE LESS THAN SHOWN.

NOTES:

1. LEAVE SUFFICIENT SLACK ON CONDUCTORS TO ALLOW REMOVAL FROM HANDHOLE FOR MAINTENANCE.
2. FOR PROPER TAPING PROCEDURE, REFER TO DRAWING CD215-12.

APPROVED		REVISIONS		MANITOBA HYDRO DISTRIBUTION STANDARDS			
ORIGINAL DRAWING SEALED BY J.J.D. RINGASH 18-05-11		18-04 0		<p align="center"><b>CONNECTION DETAIL IN STREET LIGHT STANDARD</b></p>			
DRAWN C.A.	CHECKED L.D.	DATE 18-04		<p align="center"><b>CD 310-4</b></p>		SHT	REV
						0004 OF 4	00

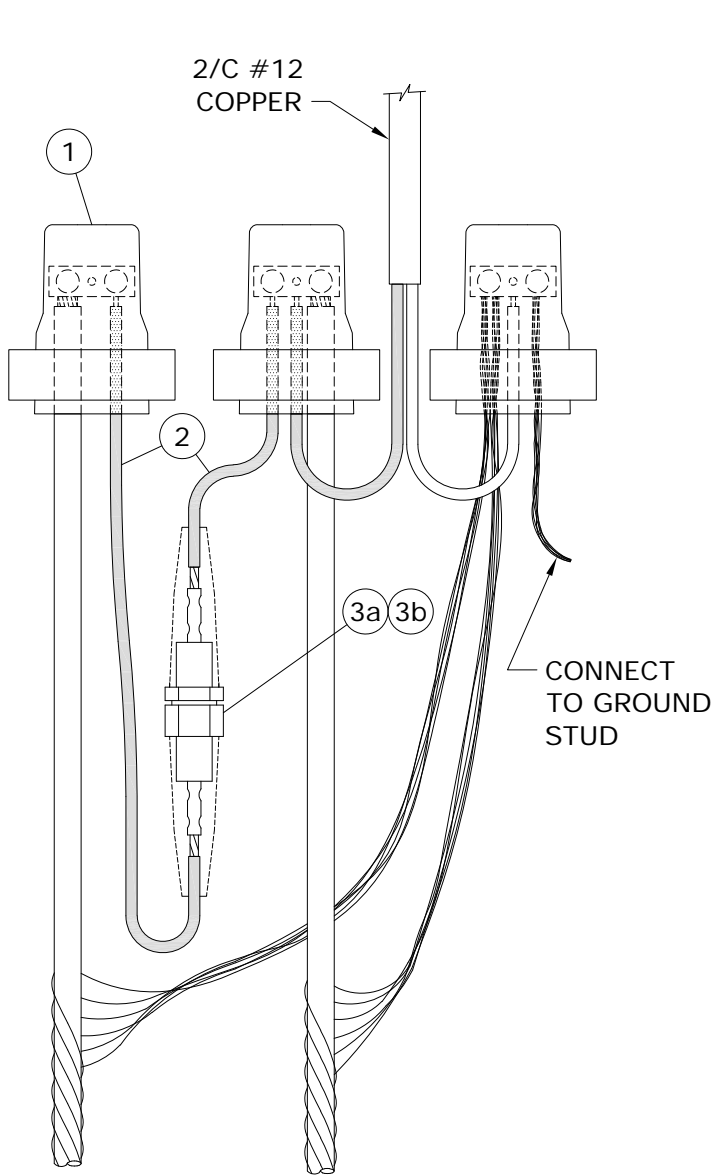

**No. 4 ALUMINUM C/N CABLE**

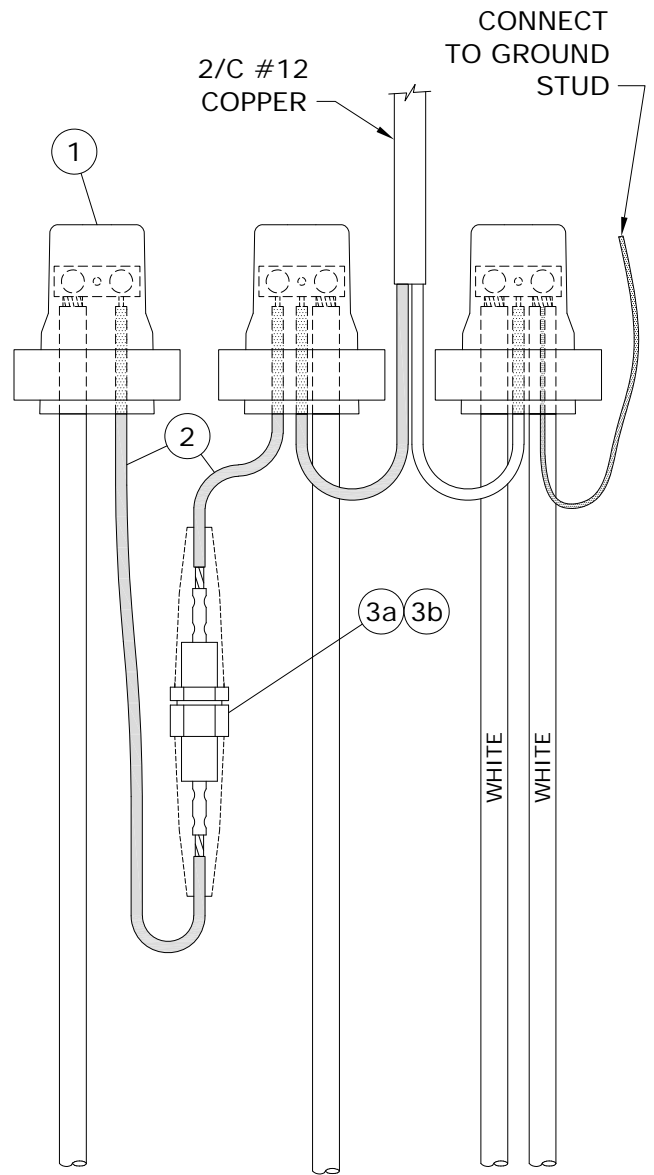

**1/0 ALUMINUM TRIPLEX CABLE**

SUPERCEDES ORIGINAL SEALED BY E. WIEBE ON 89-04-28

APPROVED		REVISIONS		MANITOBA HYDRO DISTRIBUTION STANDARDS	
ORIGINAL DRAWING SEALED BY J.J.D. RINGASH 18-03-05	17-11	2	ADDED SHT 3 & 4, MOVED PREVIOUS INFO FROM SHT1 TO SHT3, ADDED NEW GELCAP DWG, RESEALED	<b>STREET LIGHT CIRCUIT PROTECTED BY 30A FUSE IN STREET LIGHT STANDARD</b>	
	94-04	1	CONN. REVISED DUE TO INSUL. NEUTRAL		
DRAWN C.A.	CHECKED L.D.	DATE 17-11		<b>CD 310-9</b>	



**BILL OF MATERIAL**

ITEM No.	DESCRIPTION	STORES CODE No.		QUANTITY
		FOR USE WITH #4 AL. C/N	FOR USE WITH 1/0 AL. TRIPLEX	
1	GEL CAP	04-29-36	04-29-36	3
2	WIRE, # 8 CU., 600V, PVC	93-10-08	93-10-08	1m
3a	FUSEHOLDER, 15/30A C/W BOOTS	31-91-30	31-91-30	1
3b	FUSE, 30A	31-14-30	31-14-30	1

NOTES:

- 1. LEAVE SUFFICIENT SLACK ON CONDUCTORS AND FUSE HOLDER TO ALLOW REMOVAL FROM HANDHOLE FOR FUSE REPLACEMENT AND MAINTENANCE.**
2. FOR SPLICING FEED THROUGH HOT LEG, REFER TO DRAWING CD310-4.
3. FOR GEL CAP INSTALLATION INSTRUCTIONS, REFER TO DRAWING CD310-3.

*SUPERCEDES ORIGINAL SEALED BY E. WIEBE ON 94-07-03*

APPROVED		REVISIONS		MANITOBA HYDRO DISTRIBUTION STANDARDS	
ORIGINAL DRAWING SEALED BY J.J.D. RINGASH 18-03-05				<b>STREET LIGHT CIRCUIT PROTECTED BY 30A FUSE IN STREET LIGHT STANDARD</b>	
		17-11	1		
DRAWN C.A.	CHECKED L.D.	DATE 17-11		<b>CD 310-9</b>	

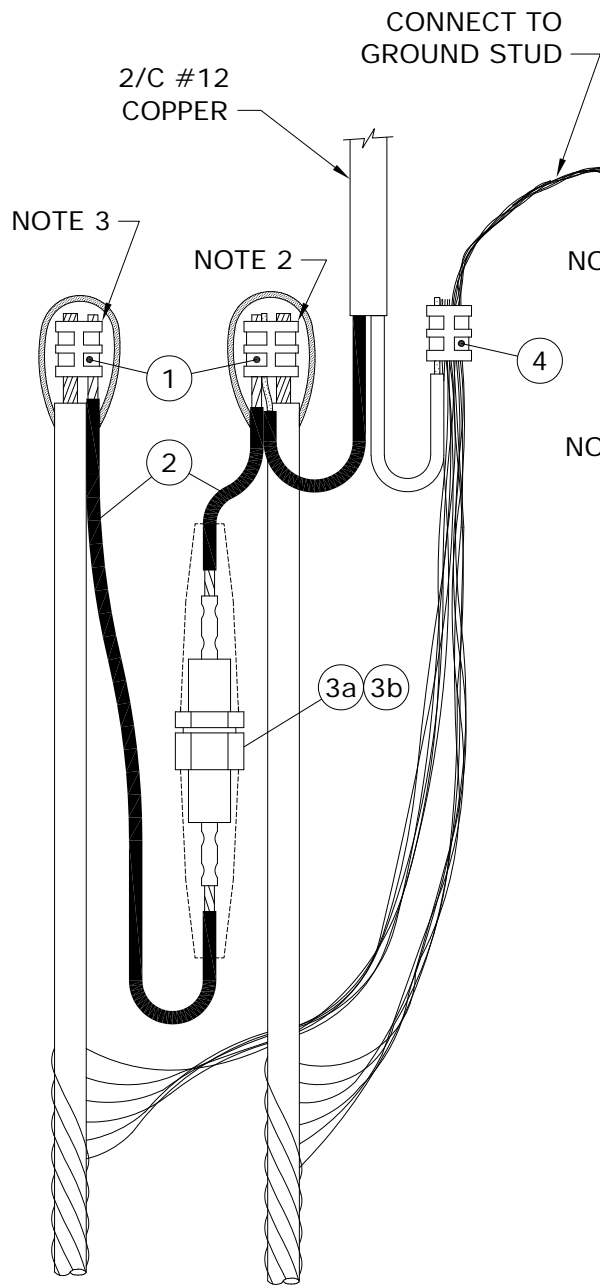

**No. 4 ALUMINUM C/N CABLE**

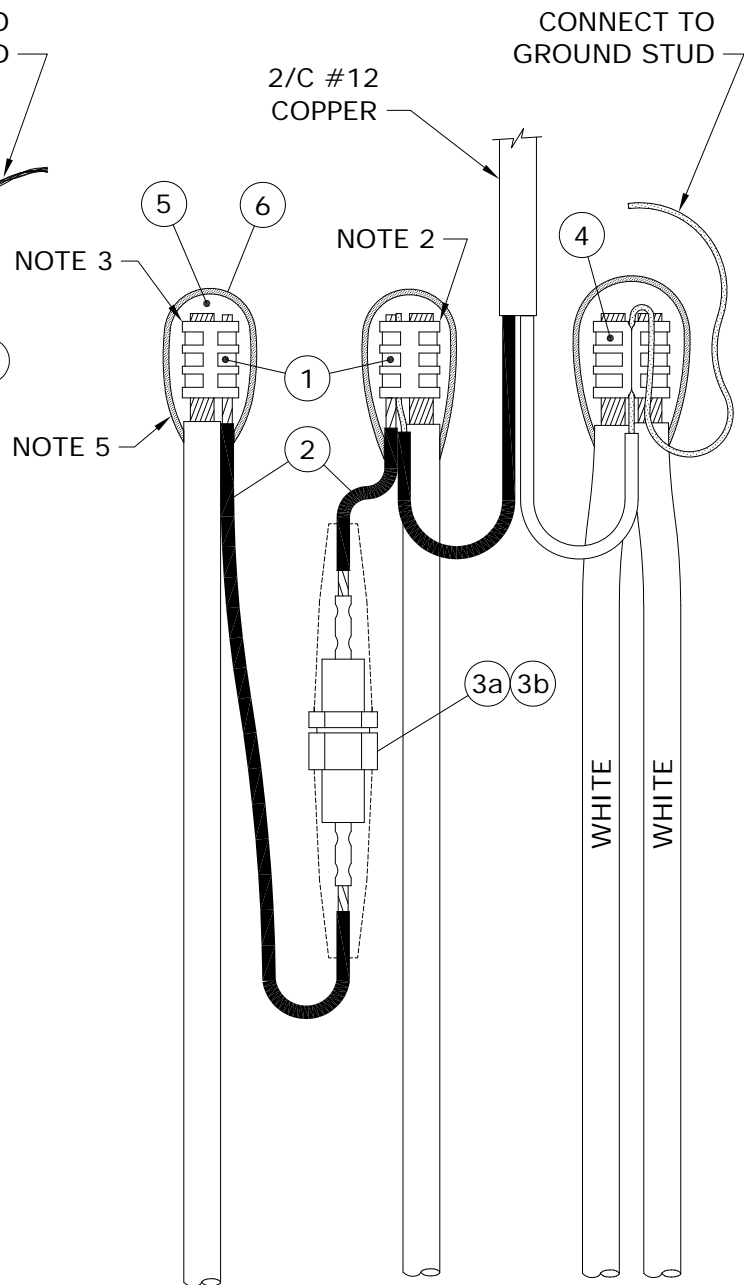

**1/0 ALUMINUM TRIPLEX CABLE**

APPROVED	REVISIONS		MANITOBA HYDRO DISTRIBUTION STANDARDS	
ORIGINAL DRAWING SEALED BY J.J.D. RINGASH 18-03-05			<b>STREET LIGHT CIRCUIT PROTECTED BY 30A FUSE IN STREET LIGHT STANDARD</b>	
17-11	0	MOVED FROM SHEET 1		
DRAWN C.A.	CHECKED L.D.	DATE 17-11	<b>CD 310-9</b>	

**BILL OF MATERIAL**

ITEM No.	DESCRIPTION	STORES CODE No.		QUANTITY
		FOR USE WITH #4 AL. C/N	FOR USE WITH 1/0 AL. TRIPLEX	
1	'H' TYPE COMPRESSION TAP	74-40-10	74-40-30	2
2	WIRE, # 8 CU., 600V, PVC	93-10-08	93-10-08	1m
3a	FUSEHOLDER, 15/30A C/W BOOTS	31-91-30	31-91-30	1
3b	FUSE, 30A	31-14-30	31-14-30	1
4	'C' TYPE COMPRESSION TAP	74-40-90	---	1
	'H' TYPE COMPRESSION TAP	---	74-40-60	1 *
5	TAPE, SELF-AMALGAMATING EPR	78-55-23	78-55-23	1/4 ROLL
6	TAPE, COLD WEATHER VINYL	78-55-98	78-55-98	1/4 ROLL

\* WHEN USING 1/0 ALUMINUM TRIPLEX 1 ADDITIONAL 'H' TYPE COMPRESSION TAP (S.C.# 74 40 60) IS REQUIRED TO CONNECT SECOND (FEED THROUGH) HOT LEG.

NOTES:

1. LEAVE SUFFICIENT SLACK ON CONDUCTORS AND FUSE HOLDER TO ALLOW REMOVAL FROM HANDHOLE FOR FUSE REPLACEMENT AND MAINTENANCE.
2. INSERT #12 COPPER AND #8 COPPER IN SMALL GROOVE.
3. INSERT DOUBLE THICKNESS OF #8 COPPER IN SMALL GROOVE.
4. FOR SPLICING FEED THROUGH HOT LEG, REFER TO DRAWING CD310-4.
5. FOR PROPER TAPING PROCEDURE, REFER TO DRAWING CD215-12.

APPROVED		REVISIONS		MANITOBA HYDRO DISTRIBUTION STANDARDS			
ORIGINAL DRAWING SEALED BY J.J.D. RINGASH 18-03-05		17-11 0		<p align="center"><b>STREET LIGHT CIRCUIT PROTECTED BY 30A FUSE IN STREET LIGHT STANDARD</b></p>			
DRAWN C.A.	CHECKED L.D.	DATE 17-11		<b>CD 310-9</b>		SHT	REV
						0004 OF 4	00

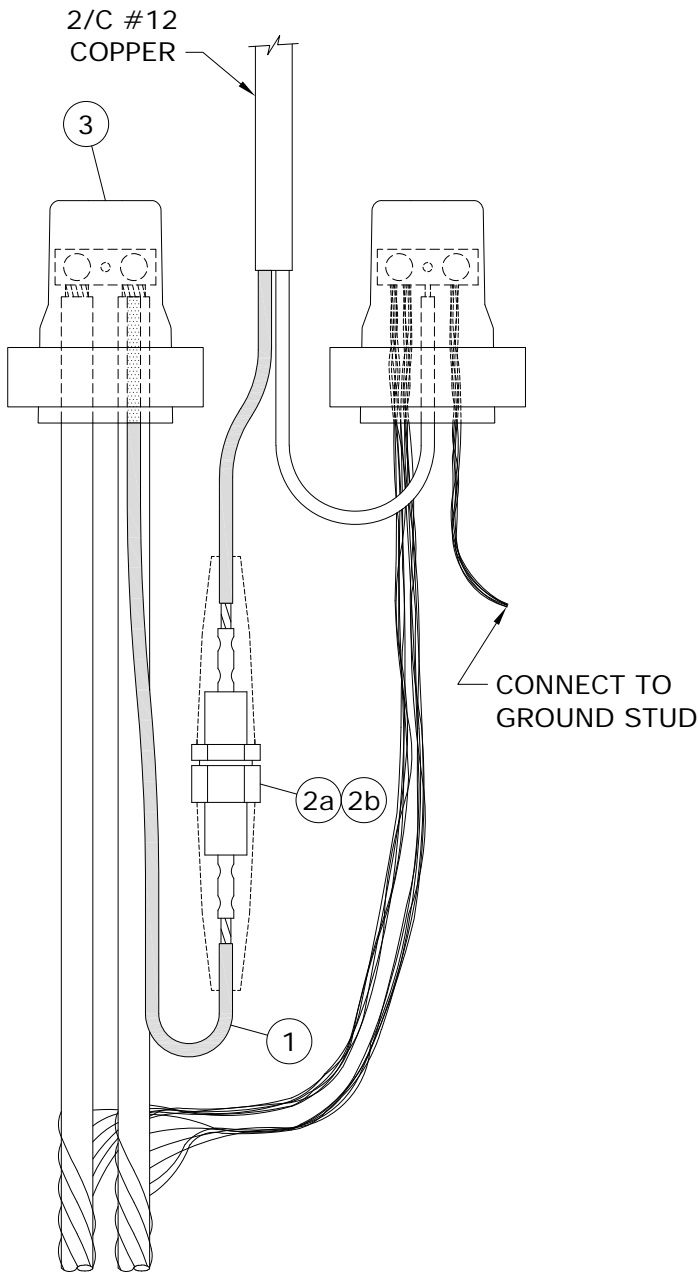

**No. 4 ALUMINUM C/N CABLE**

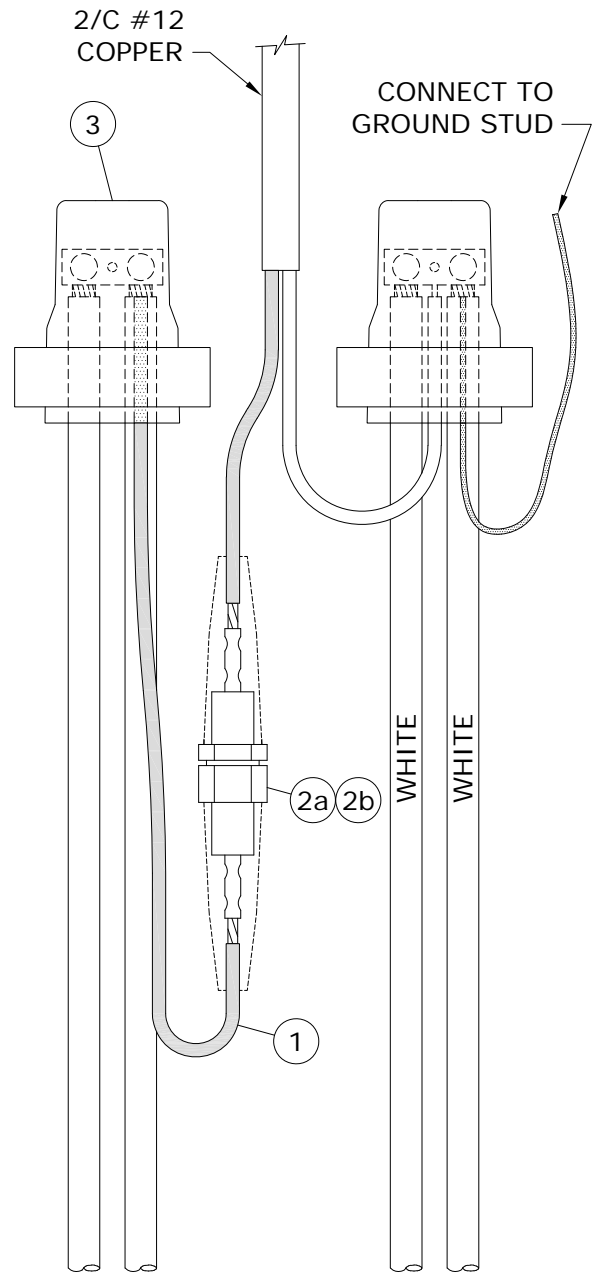

**1/0 ALUMINUM TRIPLEX CABLE**

**NOTE:**

RECOMMENDED FOR PROTECTING LUMINAIRES WHICH ARE TO BE MOUNTED ON STREET LIGHT POLES 16.8m AND HIGHER.

*SUPERCEDES ORIGINAL SEALED BY E. WIEBE ON 89-04-28*

APPROVED		REVISIONS		MANITOBA HYDRO DISTRIBUTION STANDARDS	
ORIGINAL DRAWING SEALED BY J.J.D. RINGASH 18-05-11	18-04	3	ADDED SHT 3 & 4, MOVED PREVIOUS INFO FROM SHT1 TO SHT3, ADDED NEW GELCAP, DWG, RESEALED	<b>INDIVIDUAL LUMINAIRE PROTECTED BY 15A FUSE IN STREET LIGHT STANDARD</b>	
	95-01	2	NOTE ADDED		
DRAWN C.A.	CHECKED L.D.	DATE 18-04		<b>CD 310-10</b>	

**BILL OF MATERIAL**

ITEM No.	DESCRIPTION	STORES CODE No.		QUANTITY
		FOR USE WITH #4 AL. C/N	FOR USE WITH 1/0 AL. TRIPLEX	
1	2/C #12 COPPER	93-52-12	93-52-12	1m
2a	FUSEHOLDER, 15/30A C/W BOOTS	31-91-30	31-91-30	1
2b	FUSE, STREET LIGHT, 15A	31-14-15	31-14-15	1
3	GEL CAP	04-29-36	04-29-36	2

NOTES:

- 1. LEAVE SUFFICIENT SLACK ON CONDUCTORS AND FUSE HOLDER TO ALLOW REMOVAL FROM HANDHOLE FOR FUSE REPLACEMENT AND MAINTENANCE.**
2. FOR SPLICING FEED THROUGH HOT LEG, REFER TO DRAWING CD310-4.
3. FOR END OF CIRCUIT, REFER TO DRAWING CD310-4.
4. FOR GEL CAP INSTALLATION INSTRUCTIONS, REFER TO DRAWING CD310-3.

*SUPERCEDES ORIGINAL SEALED BY E. WIEBE ON 94-07-03*

APPROVED		REVISIONS		MANITOBA HYDRO DISTRIBUTION STANDARDS				
ORIGINAL DRAWING SEALED BY J.J.D. RINGASH 18-05-11		<table border="1"> <tr> <td>18-04</td> <td>1</td> <td>ADDED SHT 3 &amp; 4, MOVED PREVIOUS INFO FROM SHT2 TO SHT4, ADDED NEW BOM WITH GELCAP, RESEALED</td> </tr> </table>		18-04	1	ADDED SHT 3 & 4, MOVED PREVIOUS INFO FROM SHT2 TO SHT4, ADDED NEW BOM WITH GELCAP, RESEALED	<p align="center"><b>INDIVIDUAL LUMINAIRE PROTECTED BY 15A FUSE IN STREET LIGHT STANDARD</b></p>	
				18-04	1	ADDED SHT 3 & 4, MOVED PREVIOUS INFO FROM SHT2 TO SHT4, ADDED NEW BOM WITH GELCAP, RESEALED		
DRAWN C.A.	CHECKED L.D.	DATE 18-04	<table border="1"> <tr> <td>SHT</td> <td>REV</td> </tr> <tr> <td>0002 OF 4</td> <td>01</td> </tr> </table>	SHT	REV	0002 OF 4	01	
SHT	REV							
0002 OF 4	01							

**CD 310-10**

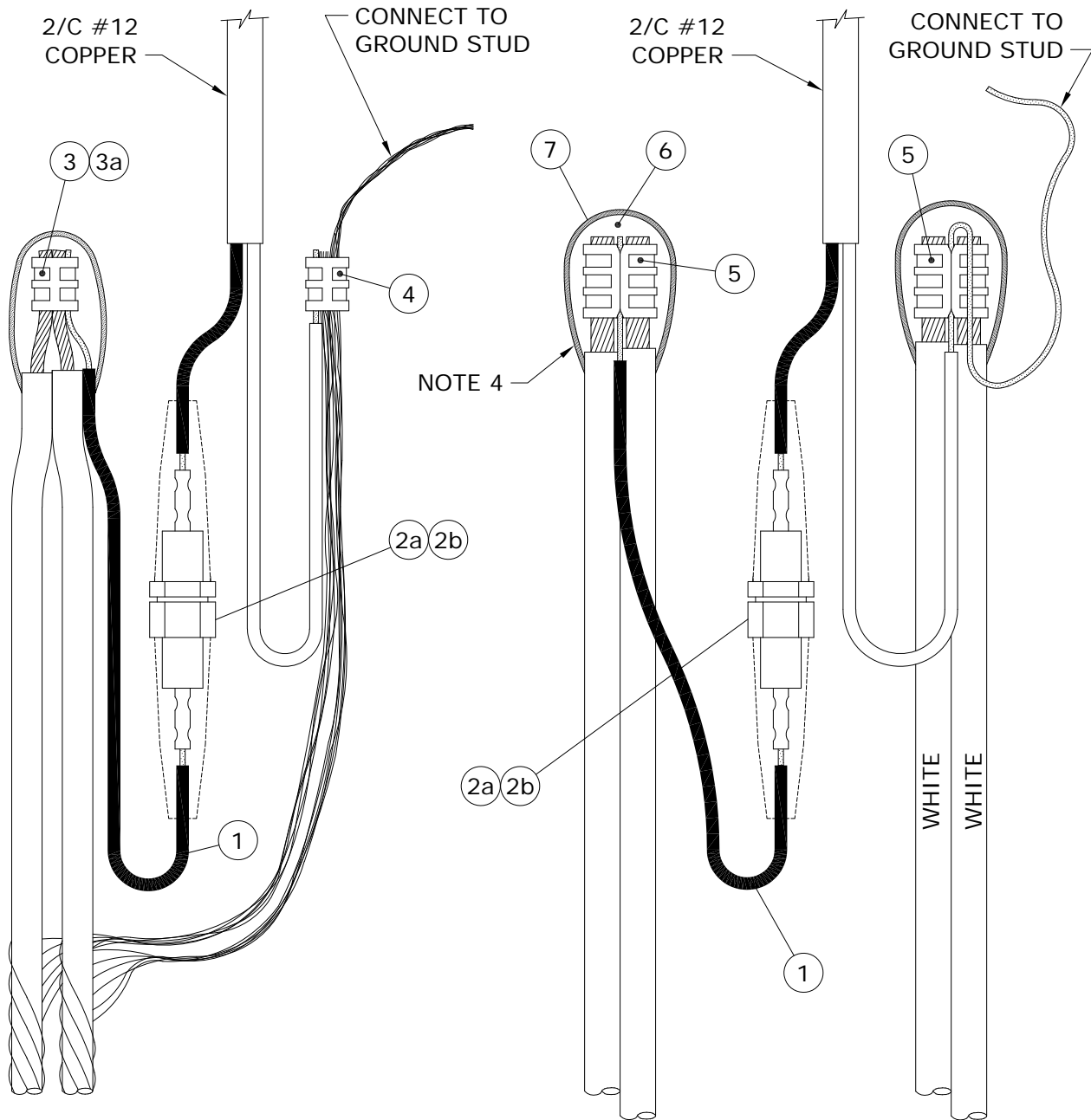

**No. 4 ALUMINUM C/N CABLE**

**1/0 ALUMINUM TRIPLEX CABLE**

**NOTE:**

RECOMMENDED FOR PROTECTING LUMINAIRES WHICH ARE TO BE MOUNTED ON STREET LIGHT POLES 16.8m AND HIGHER.

APPROVED	REVISIONS		MANITOBA HYDRO DISTRIBUTION STANDARDS	
ORIGINAL DRAWING SEALED BY J.J.D. RINGASH 18-05-11			<b>INDIVIDUAL LUMINAIRE PROTECTED BY 15A FUSE IN STREET LIGHT STANDARD</b>	
	18-04	0		
DRAWN C.A.	CHECKED L.D.	DATE 18-04	<b>CD 310-10</b>	

**BILL OF MATERIAL**

ITEM No.	DESCRIPTION	STORES CODE No.		QUANTITY
		FOR USE WITH #4 AL. C/N	FOR USE WITH 1/0 AL. TRIPLEX	
1	2/C # 12 COPPER	93-52-12	93-52-12	1m
2a	FUSEHOLDER, 15/30A C/W BOOTS	31-91-30	31-91-30	1
2b	FUSE, STREET LIGHT, 15A	31-14-15	31-14-15	1
3	'C' TYPE AL. COMPRESSION TAP	74-41-30	---	1
3a	'H' TYPE AL. COMPRESSION TAP	74-40-10	---	1 *
4	'C' TYPE CU. COMPRESSION TAP	74-40-90	---	1
5	'H' TYPE AL. COMPRESSION TAP	---	74-40-60	3 **
6	TAPE, SELF-AMALGAMATING EPR	78-55-23	78-55-23	1/4 ROLL
7	TAPE, COLD WEATHER VINYL	78-55-98	78-55-98	1/4 ROLL

- \* FOR END OF CIRCUIT WHEN USING ONLY ONE CABLE.
- \*\* AT END OF CIRCUIT, QUANTITY MAY BE LESS THAN SHOWN.

NOTES:

1. LEAVE SUFFICIENT SLACK ON CONDUCTORS AND FUSE HOLDER TO ALLOW REMOVAL FROM HANDHOLE FOR FUSE REPLACEMENT AND MAINTENANCE.
2. FOR SPLICING FEED THROUGH HOT LEG, REFER TO DRAWING CD310-4.
3. FOR END OF CIRCUIT, REFER TO DRAWING CD310-4.
4. FOR PROPER TAPING PROCEDURE, REFER TO DRAWING CD215-12.

APPROVED		REVISIONS		MANITOBA HYDRO DISTRIBUTION STANDARDS			
ORIGINAL DRAWING SEALED BY J.J.D. RINGASH 18-05-11		18-04 0		<p align="center"><b>INDIVIDUAL LUMINAIRE PROTECTED BY 15A FUSE IN STREET LIGHT STANDARD</b></p>			
DRAWN C.A.	CHECKED L.D.	DATE 18-04		<b>CD 310-10</b>		SHT	REV
						0004 OF 4	00

SUPPLY VOLTAGES

THE SUPPLY VOLTAGE FOR STREET LIGHT CIRCUITS MAY BE PROVIDED BY POLE-MOUNTED DISTRIBUTION TRANSFORMERS OR BY PAD-MOUNTED DISTRIBUTION TRANSFORMERS.

THE MAJORITY OF ROADWAY LUMINAIRES ARE RATED FOR OPERATION ON EITHER 120 VOLT OR 240 VOLT CIRCUITS AND ARE FACTORY WIRED FOR 120 VOLT OPERATION EXCEPT FOR 400 WATT H.P.S. LUMINAIRES WHICH ARE RATED FOR 120/240 VOLT OPERATION BUT ARE FACTORY WIRED FOR 240 VOLT OPERATION.

IN CASES WHERE EXCESSIVE VOLTAGE DROP IN A STREET LIGHTING CIRCUIT IS A PROBLEM, A SUPPLY VOLTAGE OF 240/480 MAY BE USED. A SUPPLY VOLTAGE OF 240/480 CAN BE OBTAINED FROM TWO SINGLE PHASE POLE-MOUNTED DISTRIBUTION TRANSFORMERS CONNECTED AS SHOWN ON DRAWING CD315-2. IF A SINGLE PHASE PAD-MOUNTED DISTRIBUTION TRANSFORMER WITH A 240/480 VOLT SECONDARY IS REQUIRED, THE TRANSFORMER MUST BE ORDERED FROM THE MANUFACTURER (SEE DRAWING CD315-2).

CAUTION:

PRIOR TO CONNECTING LUMINAIRES TO A 240 VOLT SUPPLY CIRCUIT IT IS IMPORTANT TO CHECK THE INTERNAL CONNECTIONS TO THE TERMINAL BLOCK TO ENSURE THAT THE UNIT IS PROPERLY CONNECTED FOR 240 VOLT OPERATION.

APPROVED		REVISIONS		MANITOBA HYDRO DISTRIBUTION STANDARDS	
ORIGINAL DRAWING SEALED BY E.H. WIEBE 89-04-28				<b>SUPPLY VOLTAGES FOR STREET LIGHT CIRCUITS</b>	
DRAWN W.B./CAD	CHECKED W.C.	DATE 88-08	<b>CD 315-1</b>		SHT 0001 OF 1
					REV 00



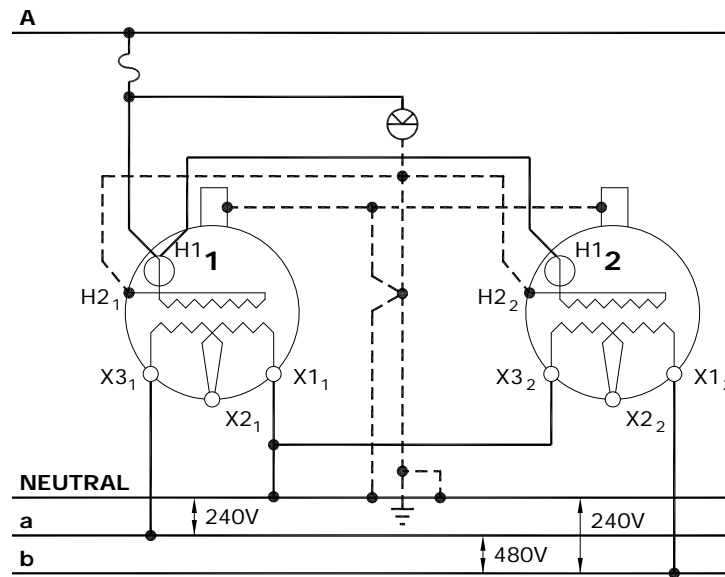

SECONDARY VOLTAGE 240/480V GROUNDED. TWO SINGLE-PHASE POLE-MOUNTED TRANSFORMERS WITH 120/240V SECONDARIES.

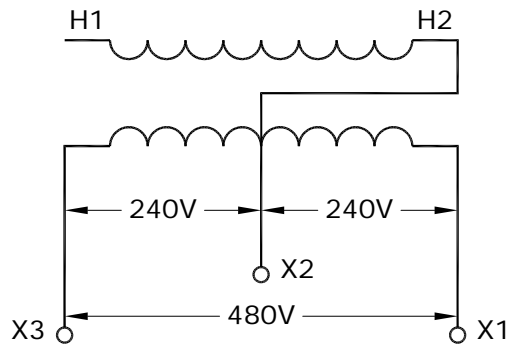

SECONDARY VOLTAGE 240/480V GROUNDED. SINGLE-PHASE PAD-MOUNTED TRANSFORMER AS SUPPLIED BY MANUFACTURER

SAFETY PRECAUTION

1. SINGLE PHASE PAD MOUNTED TRANSFORMERS WITH ABOVE SECONDARY VOLTAGES TO HAVE WARNING SIGN "**CAUTION - 240/480V SECONDARY - SEE NAMEPLATE**", STENCILLED ON THE OUTSIDE OF THE TRANSFORMER NEAR NAMEPLATE.
2. NAMEPLATES OF MODIFIED TRANSFORMERS TO BE REVISED.

PURCHASE OF 240/480 VOLT TRANSFORMER

1. INCLUDE ABOVE WARNING SIGN REQUIREMENT IN PURCHASE DESCRIPTION.

APPROVED		REVISIONS		MANITOBA HYDRO DISTRIBUTION STANDARDS		
ORIGINAL DRAWING SEALED BY E.H. WIEBE 89-04-28				<b>240/480 VOLT SUPPLY FOR STREET LIGHT CIRCUITS</b>		
		13-01	2			REVISED DIAGRAM
		90-04	1			DROPOUT DELETED
DRAWN W.B./CAD	CHECKED L.D./D.O.	DATE 88-08	<b>CD 315-2</b>		SHT 0001 OF 1	
					REV 02	

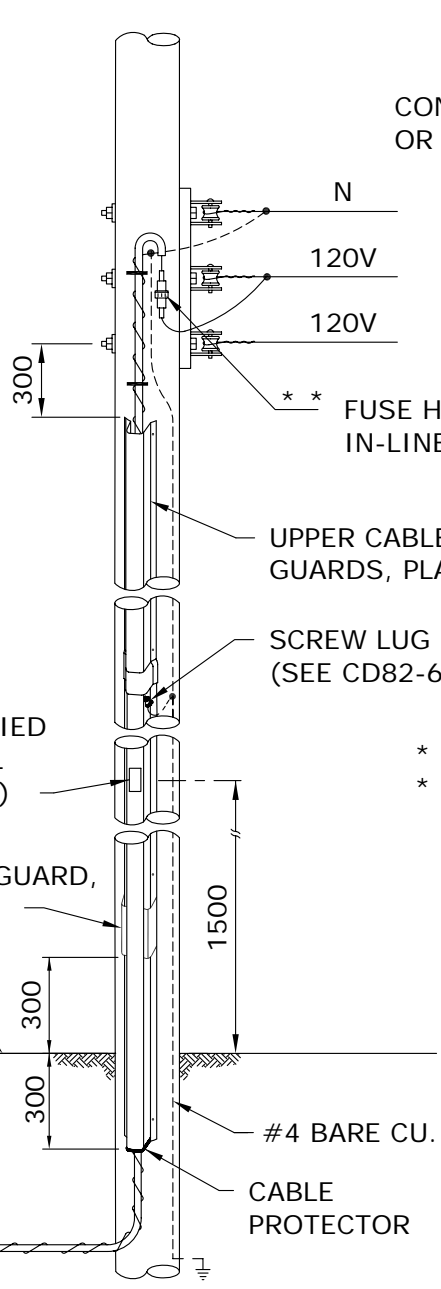

**IN-LINE  
FUSE PROTECTED**

\*\* USED WHERE POLY ISN'T USED

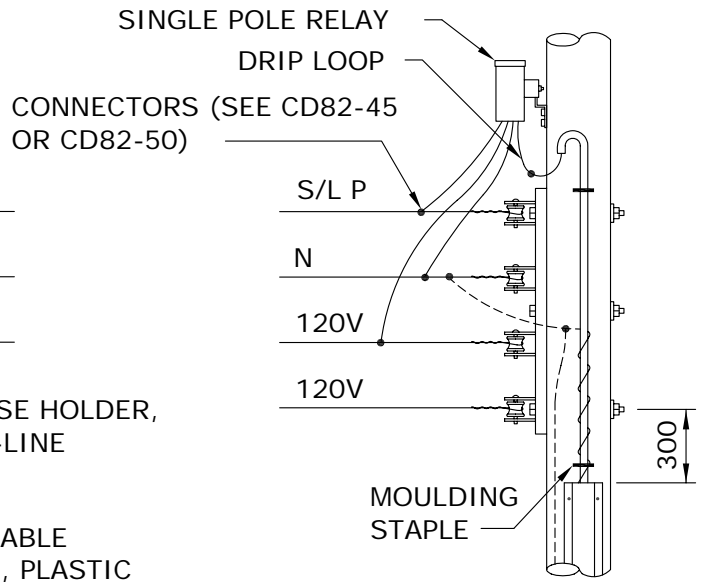

**STREET LIGHT PILOT WIRE  
CONTROLLED RELAY**

\* PHOTO-ELECTRIC CONTROLLER,  
\* TWISTLOCK RECEPTACLE

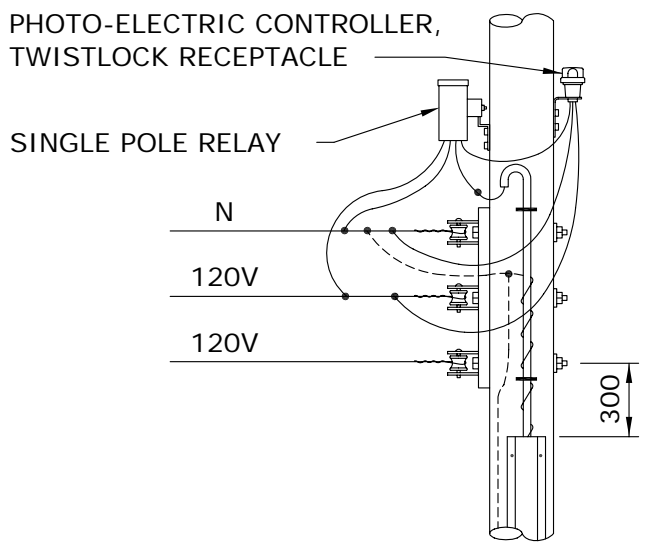

**P.E. CELL  
CONTROLLED RELAY**

\* USED WHERE ST./LT. PILOT  
DOES NOT EXIST

**NOTES:**

1. REFER TO DRAWING CD200-63 FOR CABLE GUARD INSTALLATION DETAILS.
2. INSTALL A GROUND ROD AT THE LAST POLE ON THE STREET LIGHT CIRCUIT.
3. DIMENSIONS SHOWN ARE MILLIMETRES.

APPROVED		REVISIONS		MANITOBA HYDRO DISTRIBUTION STANDARDS	
ORIGINAL DRAWING SEALED BY E.H. WIEBE 89-04-28	99-08	3	SHOW VENTED CABLE GUARD, SHEET 2 DELETED	<b>DIP POLE FOR UNDERGROUND STREET LIGHTING CIRCUIT</b>	
	94-04	2	DWG. REFERENCE CHANGED		
	92-06	1	NOTE 1		
DRAWN R.L.B./CAD	CHECKED K.C.H.	DATE 88-08	<b>CD 315-5</b>		SHT 0001 OF 1
					REV 03

CONTROL METHODS

1. LUMINAIRES CONTROLLED INDIVIDUALLY BY PHOTO-ELECTRIC CELL

THE PREFERRED METHOD FOR PROVIDING ON/OFF CONTROL OF A STREET LIGHT LUMINAIRE IS TO INSTALL A PHOTO-ELECTRIC CELL ON EACH LUMINAIRE, IF LUMINAIRES ARE MOUNTED ON HIGHER POLES (IN EXCESS OF 10.7 M OR 35 FT.) WHERE IT IS DIFFICULT TO REACH THE LUMINAIRE WITH THE LOCAL DISTRICT BUCKET TRUCK, CONSIDERATION SHOULD BE GIVEN TO USING A PHOTO-ELECTRIC CONTROLLED EXTERNALLY-MOUNTED RELAY SYSTEM.

2. PHOTO-ELECTRIC CONTROLLED EXTERNALLY-MOUNTED RELAY

SEVERAL LUMINAIRES CAN BE CONTROLLED SIMULTANEOUSLY BY INSTALLING A PHOTO-ELECTRIC CONTROLLED, EXTERNALLY MOUNTED RELAY, ON A WOOD POLE (SEE CD315-11) OR ON A STEEL STREET LIGHT POLE (SEE CD315-12). SINGLE POLE (SINGLE CIRCUIT) RELAYS ARE AVAILABLE WITH EITHER A 30 AMP OR A 60 AMP RATING. A BY-PASS SWITCH MAY BE INSTALLED TO PROVIDE A MEANS OF ACTIVATING THE STREET LIGHT CIRCUIT FOR DAYLIGHT MAINTENANCE PURPOSES.

3. STREET LIGHT RELAY USING STREET LIGHT CONTROL

ACTIVATING SUCCESSIVE SECTIONS OF STREET LIGHTING CIRCUITS BY MEANS OF A SERIES OF RELAYS (KNOWN AS A CASCADE CONTROLLED SYSTEM) IS NO LONGER USED AS A CONTROL METHOD. HOWEVER, SOME CASCADE CONTROLLED RELAY SYSTEMS REMAIN IN SERVICE. THE CONNECTION DIAGRAMS FOR A CASCADE CONTROLLED RELAY SYSTEM ARE SHOWN ON DRAWING CD315-14. DOUBLE POLE (DOUBLE CIRCUIT) RELAYS ARE NO LONGER PURCHASED, THEREFORE, DOUBLE POLE RELAYS WHICH FAIL MUST BE REPLACED WITH TWO SINGLE POLE RELAYS. BOTH THE SINGLE AND DOUBLE POLE OLDER STYLE RELAYS HAVE A 5 AMP FUSE PROTECTING THE RELAY COIL.

4. STREET LIGHT RELAY USING PILOT WIRE CONTROL

PILOT WIRE CONTROL SYSTEMS ARE NO LONGER USED FOR NEW CONSTRUCTION. HOWEVER, SOME PILOT WIRE CONTROL SYSTEMS REMAIN IN SERVICE. THE CONNECTION DIAGRAMS FOR PILOT WIRE CONTROL SYSTEMS ARE SHOWN ON DRAWING CD315-15. DOUBLE POLE (DOUBLE CIRCUIT) RELAYS ARE NO LONGER PURCHASED. THEREFORE, DOUBLE POLE RELAYS WHICH FAIL MUST BE REPLACED WITH TWO SINGLE POLE RELAYS.

5. PHOTO-ELECTRIC CONTROLLED RELAY IN BASE OF STANDARD

COMPACT RELAYS, MOUNTED IN THE BASE OF STEEL STREET LIGHT STANDARDS ARE NO LONGER USED FOR NEW CONSTRUCTION. THE COMPACT RELAY IS ACTIVATED VIA THE PHOTO-ELECTRIC CONTROLLER ON THE LUMINAIRE. IF A COMPACT RELAY FAILS AN EXTERNALLY-MOUNTED RELAY AND PHOTO-ELECTRIC CONTROLLER SHOULD BE INSTALLED (SEE CD315-12 AND CD315-13).

APPROVED		REVISIONS		MANITOBA HYDRO DISTRIBUTION STANDARDS					
ORIGINAL DRAWING SEALED BY E.H. WIEBE 89-04-28				<b>CONTROL METHODS FOR STREET LIGHT CONTROLS</b>					
DRAWN W.B./CAD	CHECKED W.C.	DATE 88-08	<b>CD 315-10</b>		<table border="1"> <tr> <td>SHT</td> <td>REV</td> </tr> <tr> <td>0001 of 1</td> <td>00</td> </tr> </table>	SHT	REV	0001 of 1	00
SHT	REV								
0001 of 1	00								

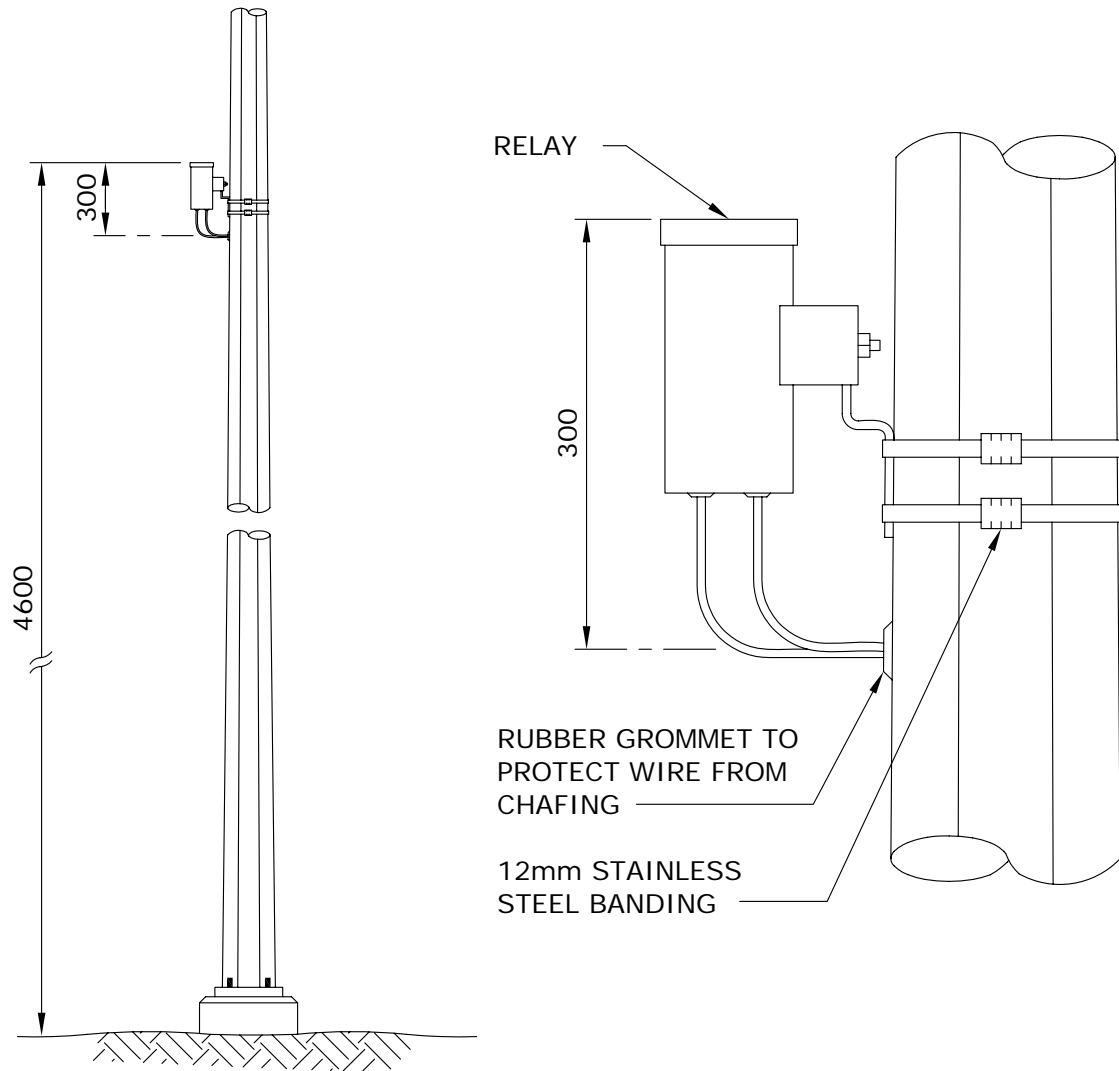

**NOTES:**

1. DRILL 25mm HOLE AT A POINT 4.3m ABOVE FINISHED GRADE.
2. INSTALL RUBBER GROMMET IN HOLE.
3. BAND RELAY TO POLE USING 12mm STAINLESS STEEL BANDING MATERIAL SO THAT THE TOP OF THE RELAY IS 300mm ABOVE THE CENTRE OF THE HOLE.
4. CONNECT RELAY LEADS TO 4.3m LENGTHS OF EQUAL SIZED CONDUCTOR AND PUSH SPLICES INSIDE POLE.
5. TAPE EXPOSED RELAY LEADS INTO A BUNDLE.
6. DIMENSIONS SHOWN ARE MILLIMETRES.

APPROVED		REVISIONS		MANITOBA HYDRO DISTRIBUTION STANDARDS					
ORIGINAL DRAWING SEALED BY E.H. WIEBE 89-04-28				<b>INSTALLATION OF EXTERNALLY-MOUNTED RELAY</b>					
DRAWN W.B./CAD	CHECKED W.C.	DATE 88-09	<b>CD 315-12</b>		<table border="1"> <tr> <td>SHT</td> <td>REV</td> </tr> <tr> <td>0001 OF 1</td> <td>00</td> </tr> </table>	SHT	REV	0001 OF 1	00
SHT	REV								
0001 OF 1	00								

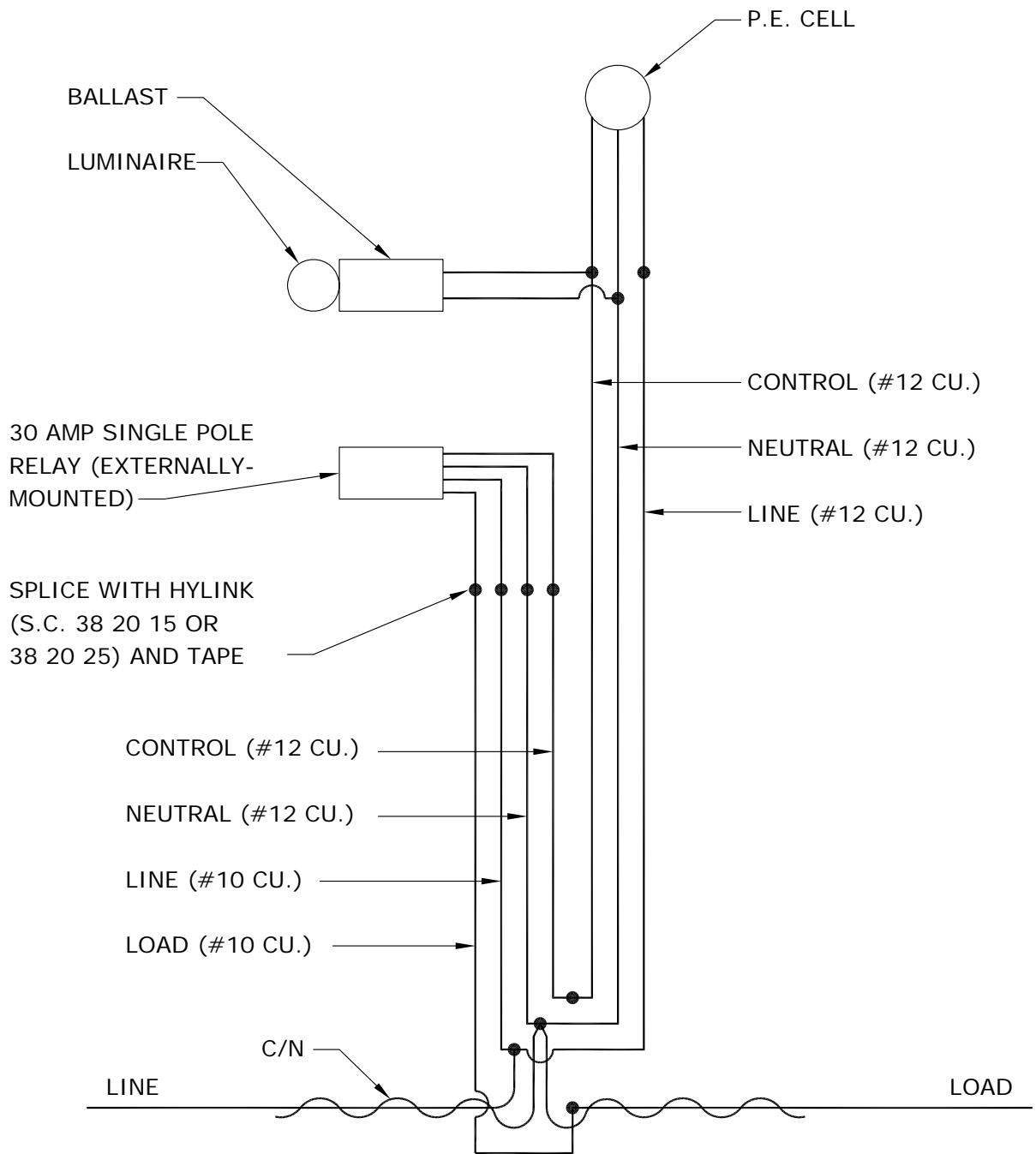

APPROVED		REVISIONS		MANITOBA HYDRO DISTRIBUTION STANDARDS	
ORIGINAL DRAWING SEALED BY E.H. WIEBE 89-04-28		94-03   1   MAXIMUM RELAY SIZE		<b>CONNECTION SCHEMATIC FOR EXTERNALLY-MOUNTED RELAY</b>	
DRAWN W.B./CAD	CHECKED W.C.	DATE 88-09	SHT 0001 OF 1		REV 01

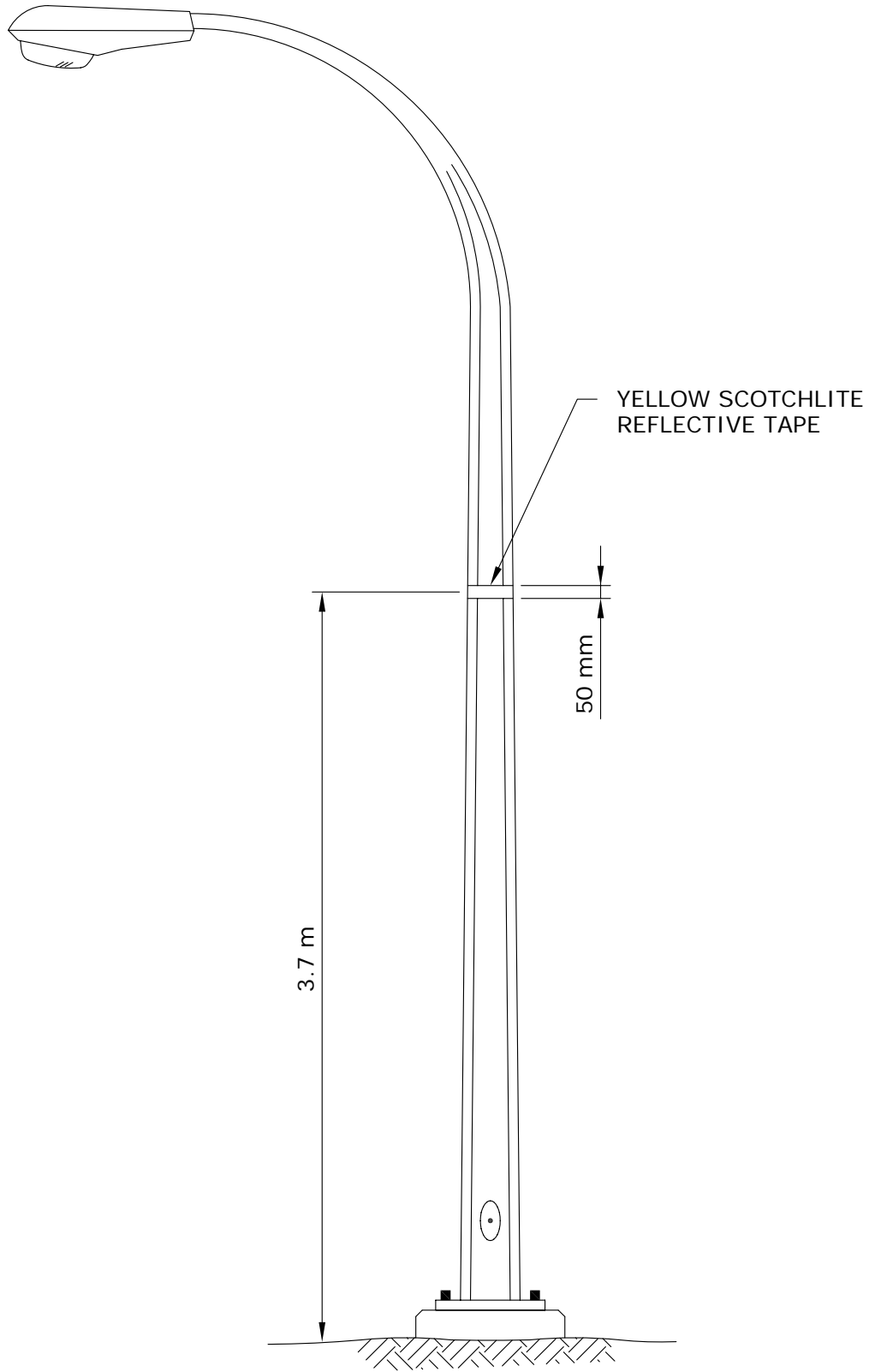

APPROVED		REVISIONS		MANITOBA HYDRO DISTRIBUTION STANDARDS	
ORIGINAL DRAWING SEALED BY E.H. WIEBE 89-04-28				<b>IDENTIFICATION OF FIRST STREET LIGHT STANDARD CONNECTION TO CIRCUIT</b>	
DRAWN W.B./CAD	CHECKED W.C.	DATE 88-09	<b>CD 315-35</b>		
			SHT	REV	
			0001 OF 1	00	

1-04431-DA-65620-0014

# **APPENDIX 'C'**

## **SAFE EXCAVATION SAFETY WATCH GUIDELINES**



# Safe Excavation & Safety Watch Guidelines



For your **SAFETY**

**Click** Before  
YouDig**MB.com**

Or call 1-800-940-3447

 **Manitoba  
Hydro**



# RELEASE OF NATURAL GAS

In the event of any damage to a natural gas pipeline (regardless of whether it is steel, plastic or aluminum) or to its protective pipe coating or tracer wire, however minor, call Manitoba Hydro immediately 204-480-5900 or 1-888-624-9376. In most cases there is no charge for minor repairs.

In case of damage causing a release of natural gas:

- Call 911 and Manitoba Hydro immediately.
- Clear people from the vicinity and prevent people from approaching the area of the leak.
- Shut off all vehicles and equipment. Remove or extinguish all sources of ignition. **DO NOT** smoke or allow open flame in the presence of natural gas.
- If a gas line has been punctured, do not remove the tool or equipment that punctured the line. This could result in a larger gas leak and pose a greater hazard.
- **DO NOT** attempt to backfill over a leaking natural gas line or attempt to stop the leak; it is safest to allow the gas to vent into the atmosphere.

Before you start to dig, contact [ClickBeforeYouDigMB.com](http://ClickBeforeYouDigMB.com) to request to have underground lines located. Manitoba Hydro will be notified and will contact you within three business days to advise of the date we will locate our electric and natural gas lines.

- Once the lines are marked we will provide you with a Facilities Locate form with specific instructions. You must obtain this form prior to excavation.
- If work has not started within 14 calendar days after the locate was provided by Manitoba Hydro, you must contact us to have the lines re-marked and receive an updated Facilities Locate form.
- Contractors must ensure that everyone on the worksite is aware of the presence of all gas and electric facilities and ensure that the Facilities Locate form is kept at the excavation site until the excavation and backfill are complete.
- The location markings must be maintained and kept visible by the person or contractor doing the excavation. Be careful that site operators do not remove the line location markings.

**In addition to contacting [ClickBeforeYouDigMB.com](http://ClickBeforeYouDigMB.com) be sure to contact any other underground services that may be in the area.**

This guideline applies to the crossing of Manitoba Hydro electrical conductors and natural gas pipelines only. When Manitoba Hydro fibre optic cables are present contractors will be referred by the Manitoba Hydro Facilities Locator to the Manitoba Hydro communications department for more information.

*Manitoba Hydro only locates facilities that it owns and has no knowledge of or responsibility for privately owned facilities. Electric conductors or gas pipes installed past the meter are owned privately by the property owner, and at times are installed below ground before entering the building. Outbuildings that are heated or have electric power, wells, septic systems, pumps, pools and hot tubs are examples where privately owned buried facilities may exist.*

*This booklet has been prepared by Manitoba Hydro for Manitoba Hydro staff, contractors and homeowners involved with excavation and is available at [hydro.mb.ca](http://hydro.mb.ca). Information on excavation and safety watch is included to inform excavators about basic requirements for excavation in the vicinity of buried electric power lines and gas pipelines. Unless otherwise indicated, gas pipelines and underground power cables will be called “lines”.*

# Table of Contents

RELEASE OF NATURAL GAS .....	2
WHY YOU SHOULD PLAN AHEAD .....	4
PLANNING LARGE PROJECTS.....	4
REGULATIONS .....	5
DEFINITIONS .....	6
EXCAVATOR PRE-MARKING.....	7
Guidelines for excavation marking.....	8
After the area is Pre-Marked.....	9
APWA UNIFORM COLOUR CODE.....	10
<b>GUIDELINES FOR EXCAVATION NEAR ELECTRICAL AND NATURAL GAS LINES.....</b>	<b>10</b>
Hand Digging to Expose Lines .....	10
Water Pressure/Vacuum System (Hydrovac).....	11
Typical Gas Service Installation .....	13
General Approach .....	13
Crossing Lines.....	14
Working Parallel to Lines .....	14
Hard Surface Removal .....	15
Line Exposed.....	16
No Relocation.....	16
Inspect for Damage.....	16
Backfilling .....	16
Access .....	17
Project Closeout .....	17
<b>SAFETY WATCH.....</b>	<b>17</b>
When is a Safety Watch required? .....	17
Why is a Safety Watch done?.....	18
Who pays for a Safety Watch?.....	18
How to arrange for a Safety Watch.....	18
<b>DIRECTIONAL BORING – CONTRACTOR GUIDELINES .....</b>	<b>19</b>
Electrical Conductors and Gas Pipelines.....	19
Observation Hole Required When Crossing Any Manitoba Hydro Facility .....	20
Drilling Parallel to Manitoba Hydro Facilities .....	21
<b>UNPLANNED CONTACT WITH ELECTRIC OR NATURAL GAS LINES .....</b>	<b>22</b>

# WHY YOU SHOULD PLAN AHEAD

When you contact ClickBeforeYouDigMB.com before you dig, we can identify buried lines so you can dig safely. This prevents injury or death, costly repairs, equipment damage, service outages, and environmental pollution.

**It is YOUR responsibility to contact all owners of buried underground services.**

## PLANNING LARGE PROJECTS

Determining the location of existing Manitoba Hydro Underground Structures within the work area should be one of the first priorities of any work. Knowing the location of all utilities infrastructure allows the third party to plan work proactively, mitigating the need for costly design changes or delays during construction.

### **Gas**

Manitoba Hydro requests that drawings be submitted for review for all projects involving ground disturbance. Drawings shall be submitted to: [gasdesign@hydro.mb.ca](mailto:gasdesign@hydro.mb.ca).

Drawings will be reviewed by Manitoba Hydro at no cost and a letter providing details of any work restrictions, specific requirements or costs will be provided to the contractor.

Drawings should be submitted a minimum of 4 weeks before the start of any excavation work. Drawings shall include the details of the proposed work and include any gas or electrical line in the work area.

### **Electric**

Contact Manitoba Hydro in Winnipeg at 204-480-5900 or outside Winnipeg at 1-888-MBHYDRO (1-888-624-9376)

You will be referred to the local district office for further instruction.

# REGULATIONS

There are several federal and provincial agencies overseeing the operation of and around natural gas pipelines and electric cables. The following regulations and safe practice guides specify requirements for both the contractor and the utility:

- Manitoba Gas Pipeline Act, Regulation 140/92 – Provides the legal definition of an excavation and outlines Excavator and Utility responsibilities.
- National Energy Board Pipeline Damage Prevention Regulations: Authorizations, SOR/2016-124; Obligations of pipeline companies, SOR/2016-133
- Manitoba Workplace Safety and Health Act and Regulation M.R. 217/2006 including Part 26, Excavations and Tunnels - Describes legal responsibilities in regards to excavating safely.
- Guideline for Excavation Work, Manitoba Workplace Safety & Health Division.
- CSA Z247 Damage Prevention Standard.

# DEFINITIONS

**Daylighting** – A term used to describe the uncovering and exposing of underground utilities to daylight without the use of mechanical excavation.

**Excavation** – includes digging, boring, pushing, ploughing, trenching, grading, post installation and breaking and displacement of soil or other material below the existing level of the ground that will disturb more than the top 150 mm (6 inches) of the ground.

**High Pressure gas line** – A natural gas line that operates in excess of 700 KPa (100psi).

**Hydrovac** – A truck or trailer that injects pressurized water from an onboard reservoir tank into the ground through a handheld wand. As the soil cover is liquefied, the resulting slurry is simultaneously extracted by a powerful vacuum and stored in an onboard debris tank for later disposal.

**Large diameter pipeline** – A natural gas pipeline that is 168.3 mm (6 inches) in diameter or larger, regardless of operating pressure.

**Safety Watcher** – A person designated by Manitoba Hydro to ensure that workers are not put at risk as a result of special hazards on the work site.

**Sonde** - A transmitter behind the bore head which registers angle, rotation, direction and temperature data.

**Tolerance Zone** – The space in which a line or facility is located, and in which special care is to be taken.

**White lining** – Designating the route and/or work area of the excavation using white paint, stakes and/or flags to outline the work area prior to the locator arriving on the site.

# EXCAVATOR PRE-MARKING

Pre-marking your proposed work site allows excavators to accurately communicate to Manitoba Hydro's facility locators where the excavation is to occur. This may be accomplished either electronically or by white lining.

For excavator pre-marking, contact [ClickBeforeYouDigMB.com](http://ClickBeforeYouDigMB.com) or call 1-800-940-3447 to communicate where the excavation is to occur and:

- Attach a sketch or map that clearly identifies the excavation area via email or
- Pre-mark the excavation area by white lining

In either scenario you will be issued a reference number and notified of the day the locator will be on site.

*When a project is too large for or not conducive to pre-marking, face-to-face meetings between Manitoba Hydro's facility locator and the excavators will be arranged at the proposed work site.*

## **White Line**

The excavator designates the route and/or area of the excavation using white paint, stakes and/or flags to outline the work area prior to the locator arriving on the site.

White paint, white stakes or white flags with the excavator's company identifier on them are permissible methods of marking.

When using stakes or flags to mark the excavation work area, do not drive them into the ground deeper than 150 mm (6 inches). Any activity which disturbs more than 150 mm (6 inches) must have the facilities located.



# Guidelines for excavation marking

The following marking illustrations are examples of how excavators may choose to mark their area of proposed excavation. The use of white marking products (e.g. paint, flags, stakes, or a combination of these) may be used to identify the excavation site.

Mark in white paint the proposed area of excavation through the use of a continuous line, dots marking the radius or arcs, dashes marking the four corners of the project, or dashes outlining the excavation project. The recommended size of each dash is approximately 150 – 300 mm (6-12 inches) in length and 20 mm (3/4 inch) in width with interval spacing approximately 1 – 5 metres (3-16 feet) apart. The maximum separation of excavation marks is to be reduced to a length that can be reasonably seen by the operator's locators when the terrain or excavation site conditions warrant it. Dots of approximately 20 mm (3/4 inch) diameter are typically used to define arcs or radii and may be placed at closer intervals in lieu of dashes.

## SINGLE POINT EXCAVATION MARKINGS

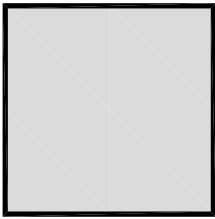

FULL LINE

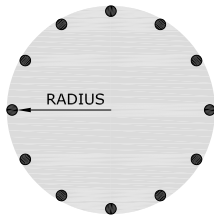

STAKE IN CENTRE WITH COMPANY NAME & RADIUS OF CIRCLE

RADIUS OR ARC

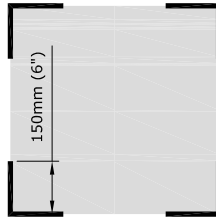

FOUR CORNERS

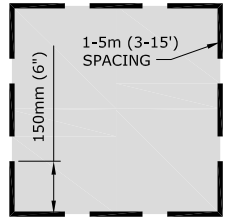

DASH LINE

If an excavation is contained within a 5 metre (16 feet) maximum radius then it can be marked with a single white stake at the centre of the excavation. The stake must clearly state the company identifier and the radius of the excavation in black lettering. This information must be conveyed to Manitoba Hydro.

## **After the area is Pre-Marked**

On the appointed date, the locator will identify the Manitoba Hydro facilities that are located in the designated work area. They will document it using a sketch or map attached to the Electric and/or Natural Gas Facilities Locate Form.









When the locator has completed locating the facilities, they will advise the excavator and indicate whether there is a conflict. The Facilities Locate form will be available and must be on site prior to excavating.

The Manitoba Gas Pipeline Act, Regulation 140/92 and the Workplace Safety and Health Act, regulations M.R.217/2006, part 26.6 require that a valid Facilities Locate form be on the work site at all times until the project is complete.

If an excavation takes place without a current locate form on site, the locate is not valid. The excavator could face consequences which may include fines and/or sanctions by Manitoba Workplace Safety and Health and Manitoba Hydro.

# APWA UNIFORM COLOUR CODE

## Underground utility marking

	<b>WHITE</b> – Proposed Excavation
	<b>PINK</b> – Temporary Survey Markings
	<b>RED</b> – Electric Power Lines, Cables, Conduit and Lighting Cables
	<b>YELLOW</b> – Gas, Oil, Petroleum, or Gaseous Materials
	<b>ORANGE</b> – Communication, Alarm or Signal Lines, Cables or Conduit
	<b>BLUE</b> – Potable Water
	<b>PURPLE</b> – Reclaimed Water, Irrigation and Slurry Lines
	<b>GREEN</b> – Sewer and Drain Lines

## GUIDELINES FOR EXCAVATION NEAR ELECTRICAL AND NATURAL GAS LINES

### Hand Digging to Expose Lines

Mechanical excavation cannot be used within 1 metre (39 inches) of an electrical or gas line until the line is physically exposed by hand. Hand exposing means exposing a buried facility, whose location has been marked by Manitoba Hydro, using non-powered tools such as a Spade or shovel (hand augers are not acceptable). A water pressure/vacuum system (hydrovac) is an acceptable alternative.

There are several things to remember when hand exposing:

- No one should ever jump on or use their entire body weight on a shovel when digging.
- Use a prying (rather than striking) motion to loosen hard dirt.
- Never probe for the facility using a sharp pointed tool such as a pick axe or pointed bar.
- Dig on an angle if possible, such that any contact with the facility is a glancing blow rather than a direct hit.

Once the line is visible, mechanical excavation equipment can be used in accordance with the guidelines for mechanical excavation.

## Water Pressure/Vacuum System (Hydrovac)

An alternative to exposing cables by hand digging is to use a water pressure/vacuum system capable of exposing Manitoba Hydro facilities without damage.

Only oscillating head type nozzles are to be used for the water wand. When excavating within 1 metre of a marked line the maximum setting of 38°C (100°F) water temperature and 10,342 Kpa (1,500 psi) must not be exceeded. The end of the vacuum tube shall be neoprene or equivalent. Expose the buried line by using a sweeping motion only, perpendicular to the locate markings, until the line is sighted. **IMPORTANT: After sighting, the line shall not be contacted by spray or vacuum to avoid damage to wraps and coatings.**

Some acceptable excavation methods:

### a) Dig Vertically

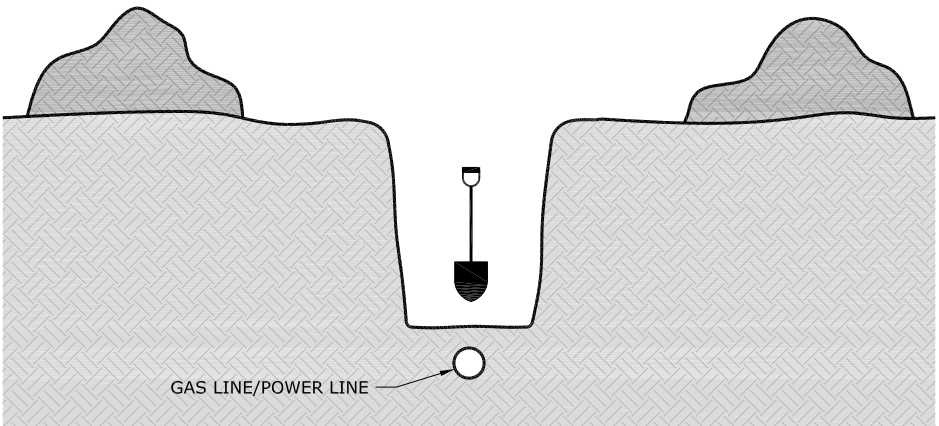

Dig a hole with a shovel directly above the line location until the line is exposed. Take care not to damage the line or coating. Mechanical excavation equipment **MUST NOT** be used to widen or deepen the hole before exposing the line.

## b) Dig Laterally

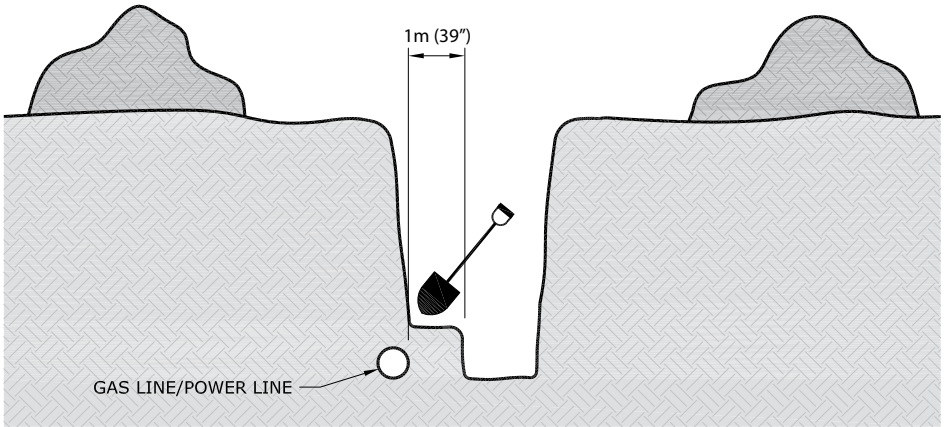

Dig a trench or bell hole 1 metre (39 inches) from the line location, parallel to the line, then hand dig laterally to expose the line.

## c) Dig Trench and excavate

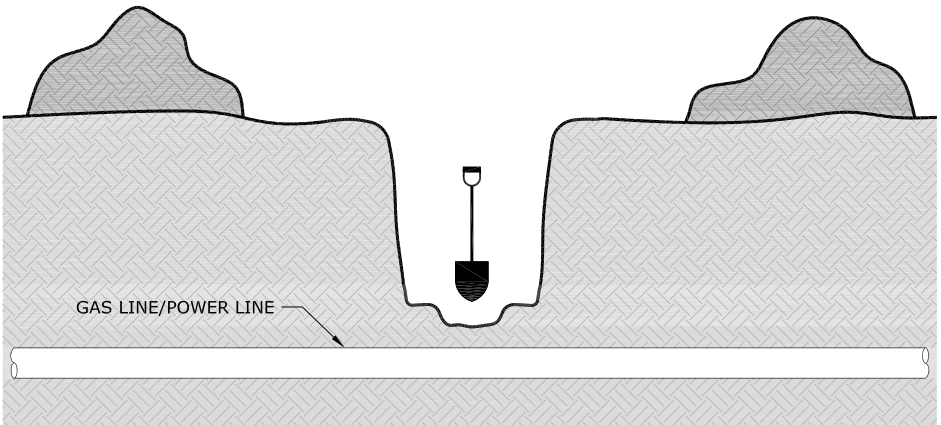

Dig a trench by hand across the full width of the excavation (perpendicular to or "across from" the line). If the line is not uncovered, mechanically excavate to one half the depth of the trench. Repeat this process until the line is exposed.

# Typical Gas Service Installation

(example only does not represent all installations)

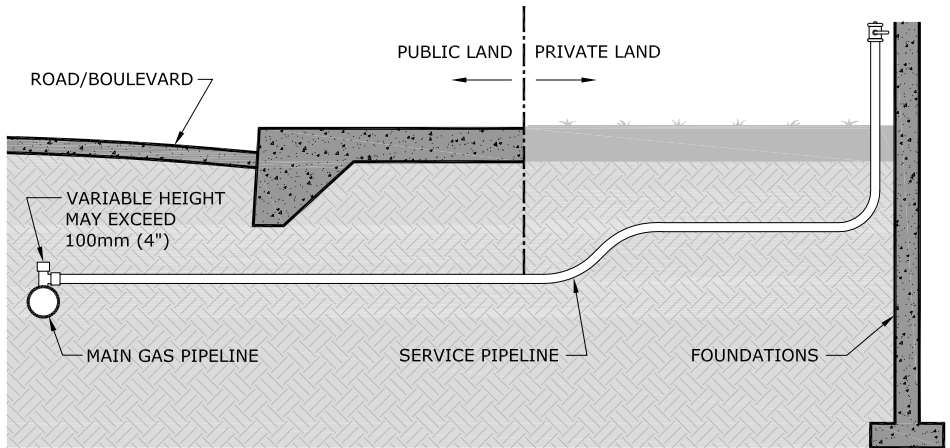

Fittings such as active or abandoned service tees may be present on gas pipelines, exercise care when excavating.

## General Approach

- When the line is not visible, mechanical excavation shall not be used within 1 metre (39 inches) of an electrical or gas line.
- When the line is visible, mechanical excavation can be used no closer than 450 mm (18 inches) to natural gas lines and 600 mm (24 inches) to electrical lines.
- When soil conditions permit, a smooth edge bucket is preferred when excavating near gas and electrical lines.
- An observer (excavator staff) located near the line must maintain communication and control of the operator at all times by the use of hand signals and verbal communication. The observer is responsible for maintaining the minimum distance from the pipe. If at any point the observer or operator is unclear of the location or orientation of the line, no digging shall occur until this is confirmed and agreed upon by all on the worksite.

## Before line is exposed

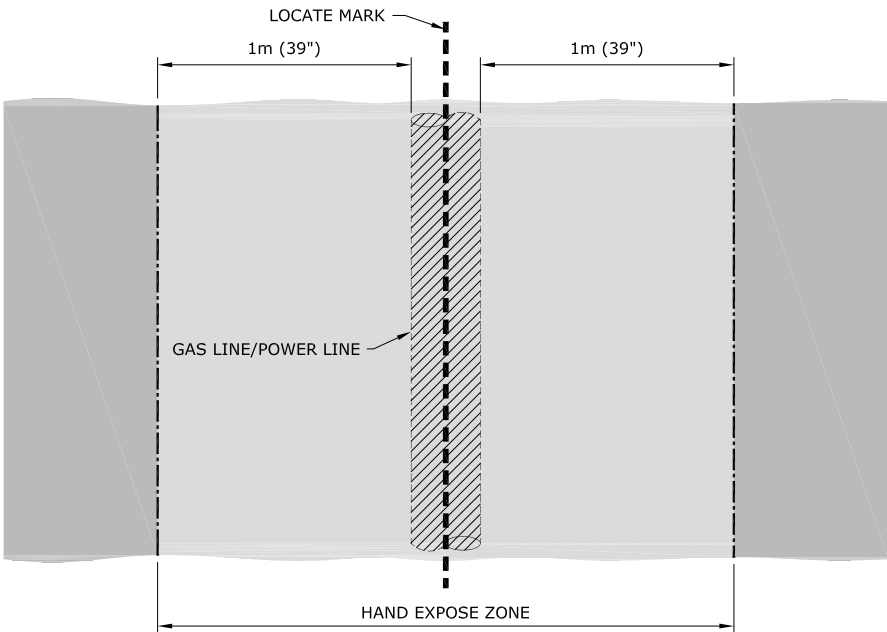

## Crossing Lines

- When crossing a line, the line is to be exposed for the width of the excavation.
- After the line is daylighted, and provided there is space for excavator access, it is recommended that excavation near the line be performed parallel to the line.

## Working Parallel to Lines

- When working parallel to a line it is not necessary to expose the full length of the line to reduce the acceptable mechanical excavation separation. A series of daylight holes along the line is acceptable. The distance between daylight holes will be a maximum of 10 metres (33 feet) or as required to define the location of the line. Daylight holes must be large enough to expose the full width of the line or lines.
- After daylighting and previewing of the line, marks shall be placed a minimum of 450 mm (18 inches) from the outside of the line at each daylight hole for gas and 600 mm (24 inches)

for electrical lines. This tolerance zone should be marked along the entire length of the work area to ensure that the operator maintains proper alignment with the line. With the line daylighted and the tolerance zone marked, it is acceptable to use mechanical excavation on the outside of the marked line of the tolerance zone.

- If at any point the line becomes obscured, it shall be remarked immediately. The observer is responsible for maintaining the minimum distance from the pipe by confirming the machine's distance and alignment with the line. The operator will orient his machine parallel to the line so their bucket remains more than 450 mm (18 inches) away for gas and 600 mm (24 inches) away for electric lines. They must preview the work prior to entering their machine and prior to any trenching.

### Once line is exposed

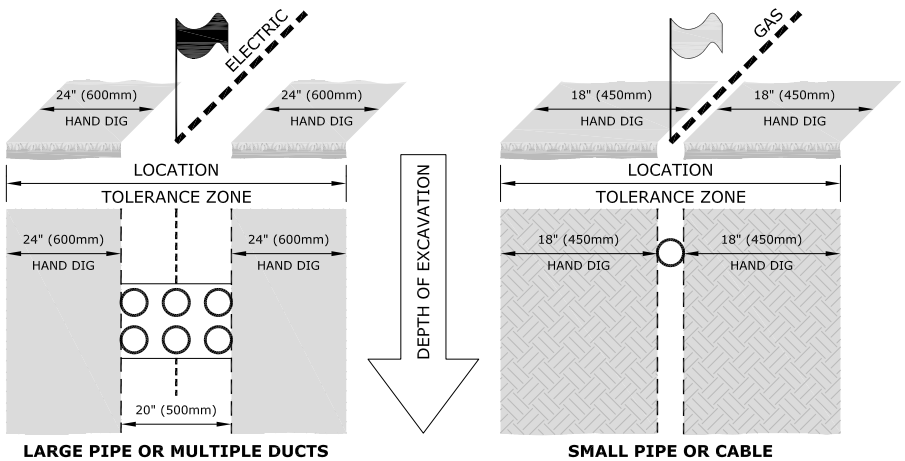

### Hard Surface Removal

- Mechanical equipment can be used to remove the asphalt or concrete road/sidewalk surface and should only be used to the depth of that surface.
- Avoid starting the pavement break directly over the marked facility.
- Start a few feet away from the marks and attempt to "peel off" the pavement or break it into small chunks for removal.



## **Line Exposed**

When a length of line is exposed consult the utility for proper handling procedures. The line may need to be supported to prevent settling or sagging.

## **No Relocation**

The line shall not be moved or relocated. No operation or work shall be done that would put stress on the line.

## **Inspect for Damage**

Electric Power Lines – If you suspect a power cable has been damaged, contact Manitoba Hydro to inspect the cable. Do not contact the cable as it may be energized.

Gas Pipelines – Thoroughly clean (with water only) and inspect the exposed gas line for damage to the pipe, yellow plastic pipe covering or tracer wire (used on plastic pipe). If damage is found, notify Manitoba Hydro. They will repair minor damage to the pipe coating or tracer wire at no charge.

Report Contact or Damage – Any contact with or damage to any line or underground cable must be reported immediately to Manitoba Hydro.

## **Backfilling**

To prevent settling or stress, the contractor is required to place clean fill under the power or gas line and compact the fill. The backfill material must be free of rocks, sharp objects or other material that could damage the line.

If the backfill material is frozen, it should be free of large frozen lumps of soil. The backfill material must be gradually placed, not dumped, on the line. Alternatively, the line may be hand padded with 300 mm (12 inches) of screened sand or soft fill before backfilling.

If mechanical protection is required, or if the backfill contains rocks, the cable or pipeline must be enclosed in a 150 mm (6 inches) envelope of screened sand.

## **Access**

Manitoba Hydro utility personnel shall have access to the excavation to inspect the underground line at any time during construction.

## **Project Closeout**

When the excavation project has been completed all flags and stakes used to mark gas and electric lines shall be removed from the site.

# **SAFETY WATCH**

Safety Watch is a program where an employee qualified by Manitoba Hydro observes the excavation work in progress and determines actions to be taken by the contractor to prevent injury, property damage or damage to Manitoba Hydro facilities.

Safety Watch personnel work with the excavator to check that:

- the excavation is done safely;
- rules and procedures related to the excavation are followed;
- the plant is located accurately;
- all documentation is accurate and complete;
- Hydrovac guidelines are followed.

**Safety Watch personnel shall be recognized as an authority on site with the ability to shut the job down.**

## **When is a Safety Watch required?**

Any excavation within 3 metres (10 feet) of a cable or pipeline may require a Safety Watch. The need for a safety watch will be assessed and identified on the Facilities Locate form. The decision to provide a Safety Watch will be based on the excavation proposed, the type of cable or pipeline, and the proximity of the excavation to the cable or pipeline.

## **Why is a Safety Watch done?**

Safety Watch service is provided to ensure the safety of customers and their contractors when working in close proximity to either energized electrical or pressurized gas lines. In addition, this protects the integrity of the utility lines minimizing the chance of an outage.

*NOTE: Typically, Safety Watch personnel are not provided for low voltage conductors (under 750 volts) or distribution pressure gas mains and services under 168.3 mm (6 inches) diameter. However, Manitoba Hydro staff may assess the situation and choose to provide Safety Watch personnel where conditions warrant.*

## **Who pays for a Safety Watch?**

Generally, Safety Watch service is provided at no cost to the homeowner for minor projects. For larger projects, the contractor may be charged at a cost shared rate. Contact the local district office for further information.

## **How to arrange for a Safety Watch.**

When an underground line is located in response to a Click Before You Dig request, the Manitoba Hydro employee will indicate whether a Safety Watch is required. Call Manitoba Hydro to arrange for a Safety Watch appointment a minimum of three business days before any excavation is to occur.

# DIRECTIONAL BORING – CONTRACTOR GUIDELINES

As with all ground disturbance activity, the excavator must first obtain a facilities locate from Manitoba Hydro.

The distance measured to Manitoba Hydro electrical conductor or gas pipeline must always be measured from the **outside** diameter or wall of the Manitoba Hydro facility to the outside diameter of the back reamer. The same measuring methodology must be used when paralleling Manitoba Hydro facilities.

When boring within the tolerance zone of a high pressure or large diameter gas pipeline or any critical distribution gas pipeline or electrical conductor, as identified by Manitoba Hydro's Facilities Locate personnel, qualified natural gas or electric Safety Watch personnel are required.

## Electrical Conductors and Gas Pipelines

Prior to directional boring across Manitoba Hydro gas and electrical lines, the buried depth must be confirmed. Acceptable practice to verify line depth is to:

- Expose the line by hand digging, or
- Expose the line by water pressure/vacuum excavation; or
- Locate on the side wall of a trench that has been excavated 1 metre (39 inches) on either side of the surface locates; or
- Use reference measurements that are known to be accurate, for example: electrical duct lines.

The drill head and/or back reamer should at all times maintain a minimum of 1 metre (39 inches) clearance from all Manitoba Hydro lines.

Where underground facility congestion does not effectively allow a 1 metre (39 inches) clearance/separation from Manitoba Hydro lines, the contractor may consult with Manitoba Hydro Engineering for site specific direction. Any deviations in clearances/separations must be provided in writing and must be present on-site when the work is being performed.

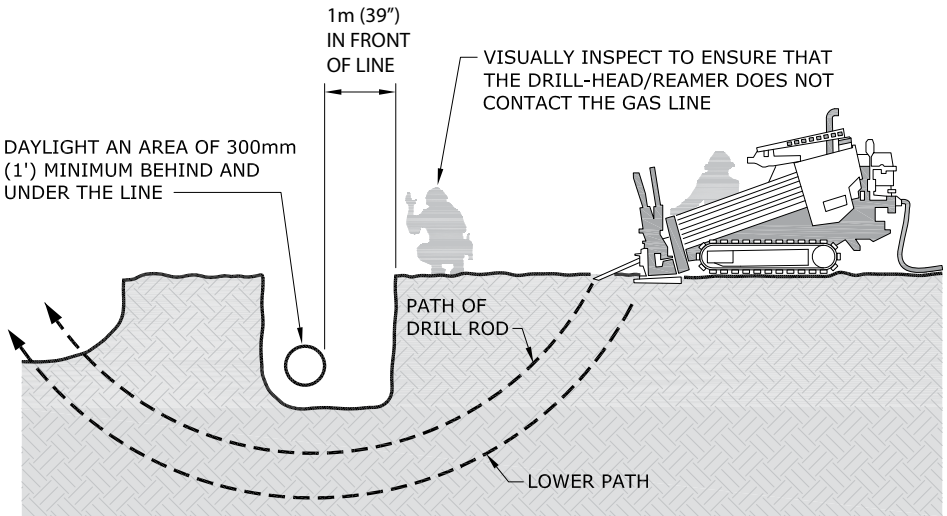

## Observation Hole Required When Crossing Any Manitoba Hydro Facility

The accuracy of the drill head location and depth must be visually verified 1 metre (39 inches) prior to crossing Manitoba Hydro facilities. An observation or discovery hole is required.

Acceptable practice for opening up the observation hole is using water pressure/vacuum or hand digging.

When boring head and/or back reamers path is crossing above a natural gas pipeline or electrical conductor the boring head and/or back reamer must be visually observed crossing the facility.

When the boring head and/or backreamer's path is crossing below a gas pipeline or electrical conductor an observer must verify that the bore head and/or reamer does not enter the observation hole within 1 metre of the line.

The minimum dimensions of the observation/discovery hole MUST BE:

- 1 metre (39 inches) in front of the gas pipeline or electrical conductor on the near side of the bore path;
- 300 mm (12 inches) on the far side of the bore path;
- 300 mm (12 inches) on each side of the bore path;
- 300 mm (12 inches) below natural gas pipeline or electrical conductor.

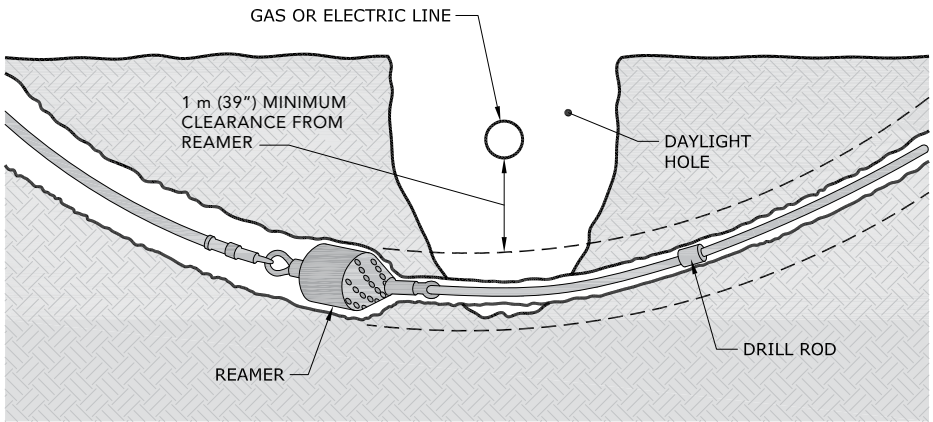

## Drilling Parallel to Manitoba Hydro Facilities

### Paralleling Electrical Conductors & Natural Gas Pipelines

There must be 1 metre (39 inches) of separation between the outside diameter of the back reamer assembly and the outside diameter of any Manitoba Hydro electrical conductors or natural gas pipelines.

*NOTE: When drilling within 1 metre (39 inches) horizontally, the drill must be kept at a depth either deeper or shallower than the existing electrical conductor or natural gas pipeline to maintain 1 metre (39 inches) separation when measured diagonally.*

If 1 metre (39 inches) horizontal separation cannot be maintained, the electrical conductor or natural gas pipeline adjacent to the bore path must be exposed. When it is not possible to de-energize electrical conductors, a Safety Hold-Off must be in place and qualified Safety Watch personnel must be on site.

When suspected of drilling within 1 metre (39 inches) of any gas or electrical lines determined by the boring head (sonde) position readings and the proximity to the locate marks, the location of the conductor or pipeline shall be verified; the electrical conductor or natural gas pipeline adjacent to the bore path must be hand exposed or exposed by water pressure/vacuum excavation as determined by Manitoba Hydro. The frequency of exposures depends on the consistency of the alignment of the existing facility.

Manitoba Hydro facilities must be exposed a minimum of once every 10 metres (33 feet), to confirm alignment. Where there is an alignment change indicated by the locator marks, the Manitoba Hydro facility shall be visually confirmed at each alignment deviation.

## **UNPLANNED CONTACT WITH ELECTRIC OR NATURAL GAS LINES**

This guideline applies to people who come in contact with or simply expose a buried utility line while excavating.

Anyone who comes in contact with buried utility lines should contact the utility owner immediately. Although there may be no apparent external damage, the impact of striking a line can cause internal structural damage that can only be determined and repaired by qualified utility personnel. Generally, we do not charge for this inspection and coating repair.

### **Abrasions**

Even if contact does not cause the utility line to stop working, a nick or cut to the outer, protective sheath of the utility line can allow ground water, laden with salts and other caustic substances, to corrode the line. Abrasions may compromise the sidewall strength of a plastic, steel or aluminum gas line.

## **Aerial**

Cables suspended along utility poles can easily be damaged if struck by a vehicle or a mechanical implement like a hydraulic lift. Cable clamps and other attachments can be pulled apart and component housings may hide damage to the electronic equipment inside.

### **Stop Work**

If any equipment is snared in the utility lines, it should be left in place. Trying to extract, flex or manipulate the line can compound the damage. Operations at the site shall stop immediately. Operators should stay in the equipment unless it is not safe (as in the case of a fire) and all others should be kept clear of the equipment as it may have become energized. If you must leave the equipment, jump clear with both feet together so you are not in contact with the equipment and the ground at the same time. Continue to hop or shuffle with your feet close together until you are a safe distance away.

### **Call It In**

The person involved in the incident should call Manitoba Hydro immediately and report the location of the hit. (In Winnipeg at 204-480-5900 or outside of Winnipeg at 1-888-624-9376.) The exact address, or street intersection, along with what type of contact occurred, will help the utility respond in an appropriate manner.







**Click**  **Before**  
**YouDigMB.com**<sup>®</sup>

**Or call 1-800-940-3447**

In addition to contacting  
[ClickBeforeYouDigMB.com](http://ClickBeforeYouDigMB.com)  
be sure to contact other  
underground services in the area.

For more information visit  
[hydro.mb.ca](http://hydro.mb.ca)

# **APPENDIX 'D'**

## **GELCAP KIT**



My Cart | My Part Lists | Sign In/Register

English (Change)

What can we help you find?

Submit

Products Industries Resources About TE My Account Innovation Support Center

**GELCAP-SL-2/0-3HOLE(B10) Product Details**

Share Print Email



**GELCAP-SL-2/0-3HOLE (B10)**

TE Internal Number: F40658-000

Active

**Power Cable Splices, Repair Sleeves and End Seals**

Always EU RoHS/ELV Compliant (Statement of Compliance)

**Product Highlights:**

- Cable Splice
- Splice Type = Stub Splice
- Splice Style = Cap
- GelCap-SL Series
- Motor Connections Application, Street Lights Application

[View all Features](#)

**Quick Links**

- [Pricing & Availability](#)
- [Search for Tooling](#)
- [Product Feature Selector](#)
- [Contact Us About This Product](#)

[Add to My Part List](#) [Request Sample](#) [Find Similar Products](#) [Buy Product](#)

Documentation & Additional Information	
<p><b>Product Drawings:</b></p> <ul style="list-style-type: none"> <li>• None Available</li> </ul> <p><b>Catalog Pages/Data Sheets:</b></p> <ul style="list-style-type: none"> <li>• None Available</li> </ul> <p><b>Product Specifications:</b></p> <ul style="list-style-type: none"> <li>• None Available</li> </ul> <p><b>Application Specifications:</b></p> <ul style="list-style-type: none"> <li>• None Available</li> </ul> <p><b>Instruction Sheets:</b></p> <ul style="list-style-type: none"> <li>• None Available</li> </ul> <p><b>CAD Files:</b></p> <ul style="list-style-type: none"> <li>• None Available</li> </ul>	<p><b>Additional Information:</b></p> <ul style="list-style-type: none"> <li>• <a href="#">Product Line Information</a></li> </ul> <p><b>Related Products:</b></p> <ul style="list-style-type: none"> <li>• <a href="#">Tooling</a></li> </ul>

Product Features (Please use the Product Drawing for all design activity)	
<p><b>Product Type Features:</b></p> <ul style="list-style-type: none"> <li>• Product Type = Cable Splice</li> <li>• Splice Type = Stub Splice</li> <li>• Splice Style = Cap</li> <li>• Series = GelCap-SL</li> <li>• Cable Type = Polymeric</li> <li>• Retention Type = Clamp</li> <li>• Armored Cable = No</li> <li>• Jacketed Cable = With</li> </ul> <p><b>Mechanical Attachment:</b></p> <ul style="list-style-type: none"> <li>• Installation Type = Cold Applied</li> </ul> <p><b>Configuration Features:</b></p> <ul style="list-style-type: none"> <li>• Conductor (Wire) Size = #14 - 2/0</li> <li>• Cable Shielding = Without</li> </ul>	<p><b>Industry Standards:</b></p> <ul style="list-style-type: none"> <li>• <a href="#">RoHS/ELV Compliance</a> = RoHS compliant, ELV compliant</li> <li>• <a href="#">Lead Free Solder Processes</a> = Not relevant for lead free process</li> <li>• <a href="#">RoHS/ELV Compliance History</a> = Always was RoHS compliant</li> </ul> <p><b>Printer/Label Features:</b></p> <ul style="list-style-type: none"> <li>• Voltage Rating (kV) = 0.6</li> </ul> <p><b>Operation/Application:</b></p> <ul style="list-style-type: none"> <li>• Application = Motor Connections, Street Lights</li> </ul> <p><b>Other:</b></p> <ul style="list-style-type: none"> <li>• Brand = Raychem</li> <li>• Comment = Clear cap to allow visual inspection.; Port B - power port to light - #14-6 AWG; Kits include connectors</li> </ul>

**Corporate Information**

- [About TE](#)
- [Investors](#)
- [News Room](#)
- [Supplier Portal](#)
- [Careers](#)
- [Terms & Conditions](#)
- [Privacy Policy](#)

**Quick Links**

- [Distributor Inventory](#)
- [Product Cross Reference](#)
- [Documents & Drawings](#)
- [Product Compliance Support Center](#)
- [Site Map](#)

**Customer Support**

- [Email or Chat With Us](#)
- [Find a Phone Number](#)
- [Knowledge Base](#)
- [Manage Your Account](#)

**Keep Me Informed**



# **APPENDIX 'E'**

## **ELECTRIC GAS LOCATE**



**ELECTRIC AND/OR NATURAL GAS FACILITIES LOCATE**  
**DEMANDE DE LOCALISATION DE CONDUITES**  
**D'ÉLECTRICITÉ ET DE GAZ NATUREL**

In case of Emergency, call /  
 En cas d'urgence, composez le  
 480-5900 or / ou  
 1-888 MB HYDRO (1-888-624-9376)  
 outside / à l'extérieur de Winnipeg



Address or location of work / Adresse ou site des travaux				Notice given by / Avis signifié par							
Name of contact on site / Nom de la personne-ressource sur le site		Contact tel. no. / Tél. de la personne-ressource		Company name (if applicable) / Nom de l'entreprise (s'il y a lieu)		Company tel. no. / N° de tél. de l'entreprise					
Description of work / Description des travaux											
Map no. / N° de carte		MIT Application #		Asbuilt no. / N° de plan définitif		DATE REQUIRED / DATE DEMANDÉE	yyyy mm dd / a. m. j.	TIME REQUIRED / HEURE DEMANDÉE	hh mm / h min.	<input type="checkbox"/> A.M.	<input type="checkbox"/> P.M.

High pressure / Haute pression	Gas main / Conduite principale de gaz	Service line / Ligne de desserte	Size / Taille	High voltage > 750 V / Haute tension > 750 V	Secondary / Secondaire	Overhead line / Ligne aérienne	Under-ground cable / Câble souterrain	Address or location of work / Adresse ou site des travaux			

Excavation constitutes a danger to the electrical cables and natural gas mains indicated below. / Les travaux d'excavation comportent des risques pour les câbles électriques et les conduites de gaz naturel indiqués ci-dessous.

Only the following utilities have been marked / Les services suivants sont les seuls à avoir été marqués :

- Electrical / Électrique :** RED markings, flags or marked stakes indicate power utility cables. / Les marques, les drapeaux ou les piquets **ROUGES** indiquent la présence de câbles électriques.
- Natural Gas / Gaz naturel :** YELLOW markings, flags or marked stakes indicate natural gas lines. / Les marques, les drapeaux ou les piquets **JAUNES** indiquent la présence de conduites de gaz naturel.

Sketch is for illustration purposes only. It is not to scale or in reference to property lines. Refer to actual stakes or markings for location(s). / Le croquis n'est qu'une illustration. Il n'est pas à l'échelle et il ne représente pas les limites des propriétés. Pour connaître l'emplacement exact, consulter les marques ou les piquets eux-mêmes.

Location or sketch / Emplacement ou croquis											
Grid area for sketch											
<input type="checkbox"/> See attached / Voir documents ci-joint											

<input type="checkbox"/> <b>SAFETY WATCH REQUIRED / EXIGENCE DE SURVEILLANCE DE SÉCURITÉ :</b> <input type="checkbox"/> Electricity / Électricité <input type="checkbox"/> Natural Gas / Gaz naturel Notify the Utility at least <b>2 business days in advance</b> of excavation to request a Safety Watch / Avertir l'entreprise <b>2 jours ouvrables avant les travaux</b> d'excavation pour demander une surveillance de sécurité.		<input type="checkbox"/> Work area is within three metres of overhead line. / La zone de travail est à moins de 3 mètres de distance d'une ligne aérienne. <input type="checkbox"/> Excavation area is within three metres but at least one metre away from power cable or gas line location. / La zone d'excavation est à moins de 3 mètres et à plus d'un mètre d'un câble électrique ou d'une conduite de gaz. <input type="checkbox"/> Hand dig within one metre of all markings/staking. / Creusez manuellement à moins d'un mètre des marques et des piquets. <input type="checkbox"/> Contact the Utility for further instructions before working/digging. / Communiquez avec le service public avant de commencer à travailler ou à creuser pour obtenir des instructions additionnelles.		Utility contact name / Personne-ressource (entreprise)		Tel. no. / N° de tél.					
Prepared by (print name) / Fait par (nom en caractères d'imprimerie)				Employee signature / Signature de l'employé(e)				DATE ADVICE GIVEN / DATE DES CONSEILS		yyyy mm dd / a. m. j.	
Received and conditions noted by (print name) / Reçu et conditions acceptées par (nom en caractères d'imprimerie)						Signature / Signature					

The recipient (**must be 18 years of age or older**) acknowledges receipt of the advice herein; and accepts and agrees to the Terms and Conditions as set out on the reverse. / Le récipiendaire, **qui doit être âgé de 18 ans ou plus**, reconnaît avoir reçu les conseils indiqués dans la présente et accepte les conditions générales indiquées au verso.

**DISTRIBUTION / DISTRIBUTION : ORIGINAL / ORIGINAL – Office / Bureau COPY / COPIE : Customer / Abonné**

**TERMS AND CONDITIONS:**

Wherever used herein, Utility refers to Manitoba Hydro and any employees or agents of the Utility.

You, by signing the front of this Electric and/or Natural Gas Facilities Locate, acknowledge that you are the owner, or an authorized agent for the owner of the location(s) of the excavation ("You") and You agree as follows:

1. The Utility shall not be liable for any claims, damages, costs, liability, damage to property, or injury or death arising from, or caused by the work or excavation, or failure to abide by the location advice or any other terms or conditions provided herein;
2. You agree to indemnify the Utility, its successors and assigns, from and against all causes of action, claims, damages, costs, liability, demands, damage to property, and injury or death which may be alleged, claimed or brought against the Utility by You, your heirs, successors, assigns, employees, contractors, invitees, or by any other third party, in respect or arising out of the work or excavation, or failure to abide by the location advice or any other terms or conditions provided herein;
3. You are responsible to provide supervision and safety watching services in respect of any work or excavation, unless it is otherwise indicated herein that the Utility shall provide same, in which case You are responsible to arrange for same with the Utility as outlined herein;
4. You shall immediately upon demand reimburse the Utility for any losses, claims, costs, or damages to the facilities of the Utility caused by or arising out of the work or excavation, or failure to abide by the location advice or any other terms or conditions provided herein.

**INSTRUCTIONS:**

**Do not excavate (including digging, boring, pushing, ploughing, or trenching the ground) without first hand digging to expose lines at a number of locations sufficient to determine their exact position and depth. If any location appears not to coincide with the markings or stakes, contact the Utility for confirmation of the location. If exposed by the excavation, cable or pipe must be inspected by the Utility for damage or safety hazards.**

**Do not attempt to locate lines by probing the ground with any pointed tool or object.**

**Stakes and markings are provided only for the work area specified by you. If work has not started within 14 days after the locate is completed by the Utility, you must again notify the Utility to re-mark the work area and provide an updated Electric and/or Natural Gas Facilities Locate form. Notify the Utility of any changes in the nature of work or work area at least two business days before beginning excavation. This form must be kept at the work area until all work has been completed. Any changes in the work or work area that was originally specified by you may require additional staking. Work should not proceed until you have received a new Electric and/or Natural Gas Facilities Locate and all facilities are located and marked.**

During the course of the work on any excavation, the excavator shall maintain, and keep in a visible condition, any markings placed there by the Utility. Do not proceed if the stakes or marks have become obliterated or are displaced. From the start of the excavation and until work and backfilling is completed, you must take every precaution to ensure that no damage will result to the lines, their coatings, protective wrapping or cathodic protection devices and no stress will be applied to the lines.

**Do not move lines or other installations, dangerous conditions may result at this or other locations.**

**Safety Watch and High Pressure excavations (as indicated on the front of this form) must be supervised by the Utility.**

**CAUTION:**

Notify the Utility of any damage, or gas and power line disturbances immediately at 480-5900 or 1 888 MB HYDRO (1-888-624-9376) outside Winnipeg.

**If natural gas leaks, you must do the following:**

- Notify all persons in any premises that may be affected
- Keep traffic and pedestrians out of the area; and
- Do not backfill any damaged facilities until the damage has been inspected by the Utility and the Utility has authorized the backfill.

**Leaking natural gas must be allowed to dissipate into the air.**

**BACKFILLING PRECAUTIONS:**

When backfilling, ensure that the cables or pipes will remain in their original position during settlement by thoroughly tamping the backfill under them; and keeping them supported.

Manitoba Hydro only locates facilities that it owns and has no knowledge of or responsibility for locating facilities owned by others.

These instructions are provided as an on-site reference. All excavations must adhere to the current Department of Labour Workplace Safety and Health Regulations and Manitoba Gas Pipe Line Excavations Regulations of the Gas Pipe Line Act. Copies of these acts can be obtained from the Utility or the Queen's Printer.

**CONDITIONS GÉNÉRALES**

*Dans les présentes, chaque fois que le terme « Entreprise » est utilisé, il fait référence à Manitoba Hydro, ainsi qu'à tout employé ou agent de l'Entreprise.*

*En signant au recto le présent formulaire de demande de localisation des conduites d'électricité et de gaz naturel, vous reconnaissez que vous êtes le propriétaire de l'emplacement (des emplacements) de l'excavation ou un agent autorisé de ce dernier (« vous ») et vous convenez de ce qui suit :*

1. *L'Entreprise ne doit pas être tenue responsable de toute réclamation ou responsabilité, ou de tous dommages-intérêts, coûts ou dommages causés à la propriété, ou de toute blessure ou tout décès découlant de l'excavation ou causés par cette dernière, ou par tout défaut de respecter les conseils relatifs aux excavations ou toute condition de la présente demande.*
2. *Vous acceptez de garantir l'Entreprise, ses successeurs et ayants droit, contre toute cause d'action, réclamation, responsabilité ou obligation, ou contre tous dommages-intérêts, coûts ou dommages causés à la propriété, ou contre toute blessure ou tout décès qui peuvent être présumés, réclamés ou déposés contre l'Entreprise par vous-même, vos héritiers, successeurs, ayants droit, employés, entrepreneurs ou invités, ou par toute tierce partie, relativement aux travaux ou à l'excavation ou à tout défaut de respecter les conseils relatifs aux excavations ou toute condition de la présente demande.*
3. *Il vous incombe de fournir une supervision et des services de surveillance de sécurité en rapport avec vos travaux ou votre excavation, sauf s'il est indiqué ailleurs dans la présente demande que l'Entreprise est responsable de fournir une telle supervision et de tels services de surveillance. Dans un tel cas, vous êtes responsable de prendre les dispositions appropriées avec l'Entreprise pour assurer une telle supervision et de tels services de surveillance.*
4. *Sur demande, vous devez rembourser immédiatement à l'Entreprise toutes les pertes ou sommes réclamées, ou tous les coûts, dommages-intérêts ou dommages causés aux installations de l'Entreprise qui découlent des travaux ou de l'excavation ou qui sont causés par ces derniers ou par tout défaut de respecter les conseils relatifs aux excavations ou toute condition de la présente demande.*

**INSTRUCTIONS**

**N'entrez jamais des travaux d'excavation, y compris le creusage ou le forage de trous, l'entassement ou le labourage du sol, ou le creusage d'une tranchée, sans tout d'abord creuser manuellement pour exposer les conduites à suffisamment d'endroits pour établir leur position et leur profondeur exactes. Si un emplacement ne semble pas coïncider avec les marques ou les piquets, communiquez avec l'Entreprise pour confirmer l'emplacement. Toute ligne ou conduite exposée par les travaux d'excavation doit être inspectée par l'Entreprise afin de vérifier si elle présente des dommages ou des risques pour la sécurité.**

**N'essayez jamais de localiser des conduites en sondant le sol à l'aide d'un objet ou d'un outil pointu.**

**Les piquets et les marques ne sont fournis que pour la zone des travaux que vous délimitez. Si les travaux ne sont pas entrepris dans les quatorze jours qui suivent la localisation effectuée par l'Entreprise, vous devez communiquer avec l'Entreprise pour faire poser à nouveau des piquets et soumettre un formulaire de localisation de lignes électriques et de conduites de gaz naturel mis à jour. Vous devez signaler à l'Entreprise toute modification apportée à la nature ou à la zone des travaux au moins deux jours ouvrables avant d'entreprendre l'excavation. Ce formulaire doit demeurer sur le site des travaux jusqu'à ce qu'ils soient terminés. Toute modification apportée à la nature ou à la zone des travaux originalement délimitée peut exiger un piquetage additionnel. Les travaux ne devraient pas être entrepris avant que vous ne receviez un nouveau formulaire de demande de localisation de conduites d'électricité et de gaz naturel et que toutes les installations ne soient localisées et marquées.**

**Les piquets et les marques doivent demeurer visibles et en bon état. N'entrez pas les travaux si les piquets ou les marques ont disparu ou ont été déplacés. Du début de l'excavation jusqu'à son parachèvement, y compris le remblayage, vous devez prendre toutes les précautions nécessaires pour veiller à ce que les lignes, leur revêtement, leur enveloppe protectrice et les dispositifs de protection cathodique ne soient pas endommagés et à ce qu'aucune contrainte ne s'applique aux lignes.**

**Ne déplacez pas les lignes ou les autres installations, car cela peut créer des conditions dangereuses à cet emplacement ou à d'autres emplacements.**

**Toute excavation qui exige une surveillance de sécurité ou porte sur des conduites haute pression (voir le recto du présent formulaire) doit être supervisée par l'Entreprise.**

**ATTENTION**

**Vous devez signaler immédiatement à l'Entreprise tous les dommages ou toute perturbation des conduites en composant le 480-5900 ou le 1 888 MB HYDRO (1 888 624-9376) (à l'extérieur de Winnipeg).**

**En cas de fuite de gaz naturel, vous devez adopter les mesures suivantes :**

- **Avertissez toutes les personnes qui sont dans les locaux qui peuvent être visés.**
- **Éloignez les piétons et la circulation automobile de la zone.**
- **Ne remblayez jamais des installations endommagées avant que l'Entreprise n'inspecte les dommages et n'autorise le remblayage.**

**Le gaz naturel qui fuit doit avoir la possibilité de se dissiper dans l'air ambiant.**

**PRÉCAUTIONS RELATIVES AU REMBLAYAGE**

**Pendant le remblayage, vous devez veiller à ce que les conduites demeurent dans leur position originale pendant le tassement du sol en pilonnant soigneusement le matériau de remblayage sous eux et en les supportant adéquatement.**

**Manitoba Hydro n'effectue que la localisation des installations qu'elle possède. Elle n'a aucune connaissance des installations que possèdent les autres services publics et n'assume aucune responsabilité pour la localisation de ces installations.**

**Les présentes instructions sont offertes à titre de référence sur place. Toute excavation doit se conformer au Règlement sur les excavations effectuées à proximité des conduites de gaz de la Loi sur les gazoducs, ainsi qu'aux règlements pertinents sur la sécurité et l'hygiène au travail du ministère du Travail. Vous pouvez vous procurer des exemplaires des documents en vous adressant à l'Entreprise ou aux Publications officielles du gouvernement provincial.**



# **APPENDIX 'F'**

## **SAMPLE JOB PLAN**



5. HAVE WE CONSIDERED (It is critical that we make note of any <b>changes</b> that may occur during the work cycle)				
<b>People</b> <input type="checkbox"/> Qualification of personnel <input type="checkbox"/> Other work groups/contractors <input type="checkbox"/> Effective Communication <input type="checkbox"/> Worker fatigue <input type="checkbox"/> Pedestrian control <input type="checkbox"/> General public <input type="checkbox"/> Traffic control <input type="checkbox"/> Safety watcher	<b>Procedures</b> <input type="checkbox"/> Limits of approach <input type="checkbox"/> De-energize/Isolation of apparatus <input type="checkbox"/> Safety hold off/Blocking required <input type="checkbox"/> Switching orders <input type="checkbox"/> Adequate cover-up <input type="checkbox"/> Grounding apparatus and vehicles <input type="checkbox"/> Work permit/Clearance to work <input type="checkbox"/> Permit checklists (soft dig, confined space, etc.) <input type="checkbox"/> Review rescue procedures <input type="checkbox"/> Spiking/Stethoscoping <input type="checkbox"/> Cut Hazards/Cut Resistant Gloves	<b>Hardware/Equipment</b> <input type="checkbox"/> Inspection of equipment <input type="checkbox"/> Inspection of tools & PPE <input type="checkbox"/> Inspection of vehicles <input type="checkbox"/> Condition of structures <input type="checkbox"/> Safe loads for rigging <input type="checkbox"/> Adequate cover-up <input type="checkbox"/> Specialized tools - calibrated/tested & up-to-date	<b>Environment</b> <input type="checkbox"/> Environment checklist <input type="checkbox"/> Underground locates <input type="checkbox"/> Weather conditions <input type="checkbox"/> Soil conditions/Shoring <input type="checkbox"/> Lighting conditions <input type="checkbox"/> Adjacent structures/Vegetation <input type="checkbox"/> Housekeeping <input type="checkbox"/> Emergency plan/procedure <input type="checkbox"/> Open excavations/Trench <input type="checkbox"/> Distractions and Interruptions	<b>Workers Affect on Environment</b> <input type="checkbox"/> Cause erosion <input type="checkbox"/> Release/spills (liquids/gases/solids) <input type="checkbox"/> Waste disposal (liquids/solids) <input type="checkbox"/> Noise <input type="checkbox"/> Fire <input type="checkbox"/> Species at risk (plant and animal) <input type="checkbox"/> Disturbing waterways/drainage/wetlands/burial grounds <input type="checkbox"/> Wildlife Habitat <input type="checkbox"/> Bio Security
WHAT ARE THE CHANGES?		HOW WILL THIS AFFECT YOUR WORK?		

6. HUMAN ERROR REDUCTION TOOLS (Consider which HER Tools you need to safely execute task or Critical Steps)		
<input type="checkbox"/> <b>Stop When Unsure / Know When to Stop</b> Stop when unclear on task / outcomes	<input type="checkbox"/> <b>Procedure Use and Adherence</b> Verify correct / accurate procedure	<input type="checkbox"/> <b>Self Check STAR</b> Stop / Think / Act / Review
<input type="checkbox"/> <b>Questioning Attitude</b> Identify confusion / doubt / uncertainty	<input type="checkbox"/> <b>Effective Communication</b> Send message / paraphrase back / acknowledge	

7. PERSONS WORKING ON THE JOB			
Designated person in charge (Print Name):		Crew cell no.:	
Designated person in charge (Signature):		Date:	yyyy mm dd
Print Full Names and classification of crew members:			
yyyy mm dd	Initial/Sign off for Tailboard Discussion		

8. OTHER CREWS AND VISITORS		Multi-crew job coordinator	Cell phone:
Be aware of <b>all</b> work crews in the area.			
WHAT OTHER CREWS ARE ON SITE	PERSON IN CHARGE	HOW WILL THEIR JOB AFFECT YOURS	

Any visitors to your site shall read and sign your Plan.

WORKSITE VISITOR SIGN OFF	DATE yyyy mm dd	WORKSITE VISITOR SIGN OFF	DATE yyyy mm dd

# **APPENDIX 'G'**

## **NETWORK COMMUNICATIONS**

**FIELD INSTRUCTIONS: Preferred Best Practice**

1. Construction Foreman to contact Customer Service Center Supervisor upon completion of project.
2. Customer Service Center Supervisor to provide a delegate that will review project details with Construction Foreman in the field.
3. Delegate to identify deficiencies and record on report. If project is accepted as complete proceed to Step 5.
4. Construction to complete deficiencies and review with delegate.
5. Once project deemed acceptable delegate to sign under "Accepted as complete by Customer Service Center Representative"
6. One copy of report to be attached to working file.
7. One copy of report to be forwarded to Customer Service Center Supervisor with close out package.
8. Construction Manager to sign under "Accepted as Complete by Construction Manager" and file with final close out package.

Network number		Description			
Foreman name (line)		Foreman name (pole)		Foreman name (underground)	
IN-SERVICE DATE	yyyy mm dd	Plan attached <input type="checkbox"/> Yes <input type="checkbox"/> No	Built as estimated <input type="checkbox"/> Yes <input type="checkbox"/> No	Field Supervisor responsible for work	

**GENERAL COMMENTS**

Prepared by (Construction Coordinator/Foreman) : Network Authenticated Signature	yyyy	mm	dd
--	------	----	----

Network number
----------------

WORK CATEGORIES	APPLICABLE		STATE ALL DEFICIENCIES OR DISCREPANCIES	CORRECTIONS COMPLETED	
	Yes	No		Department	yyyy mm dd
Poles					
Primary System					
Secondary System					
Transformer					
Equipment Data					
Street Lights					
Connect/ Disconnects					
Regulator					
Capacitors					
URD Secondary					
URD Primary					
Terminals					
Materials Location/Condition					
Site Condition					
Sub Transmission System					
Transmission System					
Station System					
GPS Locations Synchronized					

<b>SIGN OFFS (Network Authenticated Signatures):</b>			
Deficiencies identified by (Customer Service Center Representative)	yyyy mm dd	Corrections completed by	yyyy mm dd
<b>WORK COMPLETION</b>			
I hereby accept the Construction and Workmanship of this Order and Consider it to be Complete.			
Accepted as complete by (Customer Service Center Representative)	yyyy mm dd	Accepted as complete by (Construction Manager)	yyyy mm dd

# **APPENDIX 'H'**

## **PAVEMENT REPAIR FABRIC**

## **TABLE OF CONTENTS**

1.	DESCRIPTION.....	1
	1.1 General .....	1
	1.2 Definitions .....	1
	1.3 Referenced Standard Construction Specifications .....	1
2.	MATERIALS.....	2
	2.1 Approved Products .....	2
	2.2 Material Identification .....	2
	2.3 Storage and Handling .....	2
	2.4 Certification .....	2
	2.5 Pavement Repair Fabric Properties.....	2
3.	CONSTRUCTION METHODS .....	4
4.	QUALITY ASSURANCE TESTING .....	5
5.	MEASUREMENT AND PAYMENT .....	5



## **1. DESCRIPTION**

### **1.1 General**

1.1.1 This specification covers the supply and installation of pavement repair fabrics for reinforcement of asphalt layers, distribution of loads, and reducing reflective cracking distresses.

### **1.2 Definitions**

1.2.1 Pavement Repair Fabric composed of fiberglass strands coated with an elastomeric polymer and formed into a grid structure.

1.2.2 Minimum Average Roll Value (MARV) is Property value calculated as typical minus two standard deviations. It shall yield a 97.7 percent degree of confidence that any sample taken during quality assurance testing will exceed the value reported.

1.2.3 Apertures are the open spaces formed between the interconnected network of longitudinal and transverse ribs of a fabric.

1.2.4 Type A Pavement Repair Fabric will be used for full width asphalt reinforcement by allowing asphalt particles to penetrate through the fabric to achieve high interlock and effective bonding of the two asphalt lifts.

1.2.5 Type B Pavement Repair Fabric is high strength fabric in the cross-machine direction and will be used for localized repair reinforcement (*i.e.* at joints and cracks) to minimize both thermal and stress related reflective cracking.

### **1.3 Referenced Standard Construction Specifications**

1.3.1. CW 3110 – Sub-Grade, Sub-Base and Base Course Construction.

1.3.2. CW 3410 – Asphaltic Concrete Pavement Works

1.3.3. Approved Products for Surface Works.

## **2. MATERIALS**

### **2.1 Approved Products**

- 1.1.1 Use only those materials listed as Approved Products for Surface Works. The Approved Products are available at the City of Winnipeg, Corporate Finance, Material Management Internet site at:  
[https://www.winnipeg.ca/finance/findata/matmgt/std\\_const\\_spec/current/Docs/Approved Products\\_Surface\\_Works.pdf](https://www.winnipeg.ca/finance/findata/matmgt/std_const_spec/current/Docs/Approved_Products_Surface_Works.pdf)

### **2.2 Material Identification**

- 2.2.1. Pavement Repair Fabric shall be labelled in accordance with ASTM D4873/D4873M, and must clearly show the manufacturer name, product style number and roll number. Products without proper identification or labelling, mislabelling, or misrepresentation of materials shall be rejected.

### **2.3 Storage and Handling**

- 1.3.1 Pavement Repair Fabric rolls shall be elevated off the ground and adequately covered to protect them from site construction damage, precipitation, any contamination of dirt or dust and any other deleterious materials.
- 1.3.2 Pavement Repair Fabric rolls shall be protected from extended ultraviolet radiation including sunlight, chemicals that are strong acids or strong bases, flames including welding sparks, excess temperatures, and any other environmental conditions that may damage the physical properties of the fabric.
- 1.3.3 Store and handle the Pavement Repair Fabric in accordance with the manufacturer's recommendations. Manufacturer's data sheets shall include preparation instructions and recommendations as well as storage and handling requirements and recommendations.

### **2.4 Certification**

- 1.4.1 The Contractor shall provide Manufacturer's Mill Certificate and MARV Roll Data to the Contract Administrator prior to installation. The Certification shall state that the Pavement Repair Fabric meets MARV requirements as evaluated under the Manufacturer's quality control program. The Certification shall be attested to by a person having legal authority to bind the Manufacturer. The Pavement Repair Fabric shall be annually tested by accredited a third party testing facility.
- 1.4.2 The Contractor shall provide a letter to the Contract Administrator stating the product name, manufacturer, style number, and other pertinent information to fully describe the Pavement Repair Fabric.
- 1.4.3 All testing and data shall be in accordance with approved ASTM standards. Data reported in accordance with other standards will not be accepted.

### **2.5 Pavement Repair Fabric Properties**

- 2.5.1. Pavement Repair Fabric shall consist of a high strength, fiberglass grid custom knitted and coated with an elastomeric polymer and self-adhesive glue with square or rectangular opening configurations.
- 2.5.2. The axis with the least strength will be taken as the ultimate strength of the fabric for any given property.

2.5.3. Type A Pavement Repair Fabric shall meet the requirements in Table CW 3140.1.

**Table CW 3140.1 – Type A Pavement Repair Fabric Property Requirements**

Physical Property	Machine Direction	Cross-Machine Direction	Test Method
Tensile Strength, Minimum	100 kN/m	100 kN/m	ASTM D 6637
Tensile Strength @ 2% Strain, Minimum	80 kN/m	80 kN/m	ASTM D 6637
Secant Stiffness EA at 2% Strain	4,000 kN/m	4,000 kN/m	ASTM D 6637
Elongation at Break, Maximum	3%		ASTM D 6637
Coating Softening Point, Minimum	150 °C		ASTM D 36
Coating Melting Point, Minimum	350 °C		ASTM D 276
Glass Melting Point, Minimum	820 °C		ASTM D 338
Mass/Unit Area, Minimum	420 g/m <sup>2</sup>		ASTM D 5261

2.5.4. Type B Pavement Repair Fabric shall meet the requirements in Table CW 3140.2.

**Table CW 3140.2 – Type B Pavement Repair Fabric Property Requirements**

Physical Property	Machine Direction	Cross-Machine Direction	Test Method
Tensile Strength, Minimum	100 kN/m	200 kN/m	ASTM D 6637
Tensile Strength @ 2% Strain, Minimum	80 kN/m	160 kN/m	ASTM D 6637
Secant Stiffness EA at 2% Strain	4,000 kN/m	8,000 kN/m	ASTM D 6637
Elongation at Break, Maximum	3%		ASTM D 6637
Coating Softening Point, Minimum	150 °C		ASTM D 36
Coating Melting Point, Minimum	350 °C		ASTM D 276
Glass Melting Point, Minimum	820 °C		ASTM D 338
Mass/Unit Area, Minimum	420 g/m <sup>2</sup>		ASTM D 5261

2.5.5. All physical property requirements are Minimum Average Roll Values (MARV) determined in accordance with ASTM 4759. Values not labelled as MARV will not be accepted.

2.5.6. Aperture Sizes shall be as follows:

2.5.6.1. Between 10 mm and 14 mm for pavement repair fabric immediately below or within Type 1A asphalt layer.

2.5.6.2. Between 19 mm and 25.4 mm for pavement repair fabric immediately below or within Type III asphalt layer.

2.5.7. If the fabric has a rectangular aperture size, the smaller dimension shall be used to establish the suitable Pavement Repair Fabric.

### **3. CONSTRUCTION METHODS**

- 3.1. Pavement Repair Fabric shall not be placed when weather conditions, in the opinion of the Contract Administrator, are not suitable for installation including heavy rainfall, extreme cold or frost conditions, or extreme heat.
- 3.2. Make all repairs as required prior to placement of Pavement Repair Fabric. Seal cracks and fill holes using a method that provides a proper level surface. Receiving surface shall be smooth, with the existing cracks pretreated.
- 3.3. Surfaces shall be mechanically cleaned by sweeping and vacuuming and be free of oil, vegetation, sand, dirt, water, gravel, and other contaminants prior to placement of Pavement Repair Fabric.
- 3.4. Pavement Repair Fabric placement should not be undertaken if rain is likely to fall prior to covering the fabric with an asphalt mat overlay. Pavement Repair Fabric that is placed and will not adhere due to moisture shall be removed and replaced at the Contractor's expense.
- 3.5. Pavement Repair Fabric shall be laid out by mechanical means or by hand using sufficient pressure to eliminate ripples. Remove any ripples by pulling the fabric tight. Cutting of the fabric may be permitted on tight radii to prevent ripples.
- 3.6. Transverse joints shall be overlapped 75 mm or as recommended by the manufacturer, whichever is greater. Longitudinal joints shall be overlapped 37.5 mm or as recommended by the manufacturer, whichever is greater.
- 3.7. Prior to the asphalt topping placement, the fabric shall be inspected by the Contract Administrator for damage during installation. Damaged fabric shall be removed and replaced at the Contractor's expense.
- 3.8. Activate self-adhesive glue by rolling with a rubber coated drum roller or a pneumatic tire roller. In no instance shall steel-wheeled or vibratory rollers be used. Rolling shall continue until the adhesive is activated and the fabric is bonded to the leveling course.
- 3.9. Roller tires shall be kept clean to the satisfaction of the Contract Administrator.
- 3.10. If bonding of the fabric is not readily achieved, it shall be removed and replaced at the Contractor's expense.
- 3.11. Pavement Repair Fabric shall be laid and rolled over ironworks (e.g., manhole covers). Once the fabric has been rolled, those portions covering the ironworks shall be removed by cutting the fabric with a utility knife or other methods approved by the Contract Administrator.
- 3.12. Protect the Pavement Repair Fabric until placement of the finished asphalt topping.
- 3.13. Where a tack coat or emulsified asphalt is specified, the approved tack coat/emulsion and dose should be used as recommended by the manufacturer in conjunction with the Pavement Repair Fabric. Tack coat or emulsified asphalts shall not be diluted. Unless otherwise recommended by the manufacturer, apply tack coat or emulsified asphalt at the rate of 0.35 liters per square meter of surface area.
- 3.14. Where tack coat or emulsified asphalt is placed prior to the fabric, it must fully cure prior to placement of the fabric. Where tack coat or emulsified asphalt is placed after the fabric, it must fully cure prior to construction traffic, including paving, travelling on the surface.

- 3.15. Prevent spattering of tack coat or emulsified asphalt when placed adjacent to curbs, gutters, structures and other adjacent surfaces. Clean any surfaces where it has been contaminated by the tack coat or emulsified asphalt.
- 3.16. Leveling course or overlay layer shall be a minimum thickness of 40 mm. Place and compact asphalt over the Pavement Repair Fabric in accordance with CW 3410.

#### **4. QUALITY ASSURANCE TESTING**

- 4.1. The Contract Administrator shall test the adhesion for pavement repair fabric in field during construction is as follows:
  - 4.1.1 Place approximately 1 m<sup>2</sup> of fabric on a prepared surface that is representative of the project conditions.
  - 4.1.2 Activate self-adhesive glue by rolling with a rubber-tired roller or by applying adequate pressure to fully activate the pressure-sensitive adhesive.
  - 4.1.3 Use a calibrated spring balance by inserting the hook of the balance under the centre of the fabric and pulling upward until the fabric starts to pull away from the surface.
  - 4.1.4 A 9 kg pull is required without pulling the grid free or creating ripples in the fabric.

#### **5. MEASUREMENT AND PAYMENT**

- 5.1. Supply and installation of Pavement Repair Fabric will be measured on an area basis and paid for at the Contract Unit Price per square metre for "Supply and Install Pavement Repair Fabric". The area to be paid for will be the total number of square metres of Pavement Repair Fabric, supplied and installed in accordance with this specification, accepted and measured by the Contract Administrator.
- 5.2. Only material placed within the designated limits will be included in the payment for "Supply and Install Pavement Repair Fabric".
- 5.3. No measurement or payment will be made for Pavement Repair Fabric removed and replaced due to improper installation or damaged materials.
- 5.4. No measurement or payment will be made for transverse and longitudinal overlap.