

**1 SECTION DETAIL**  
A2 SCALE: 6" = 1'-0"

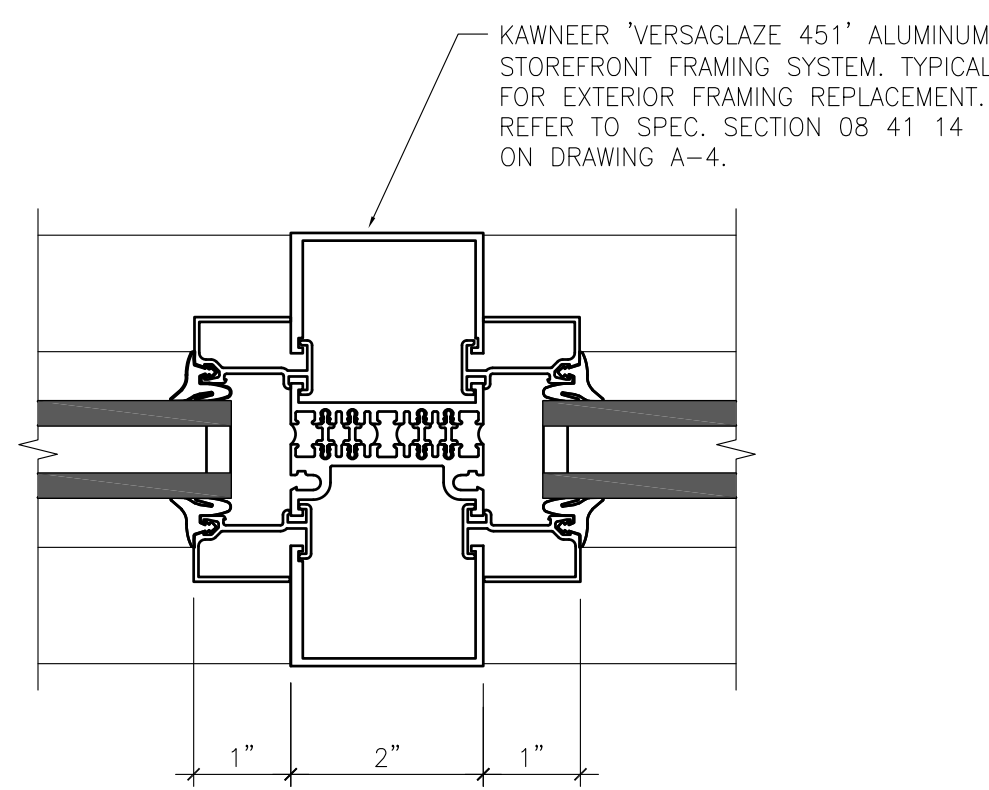

**2 SECTION DETAIL**  
A2 SCALE: 6" = 1'-0"

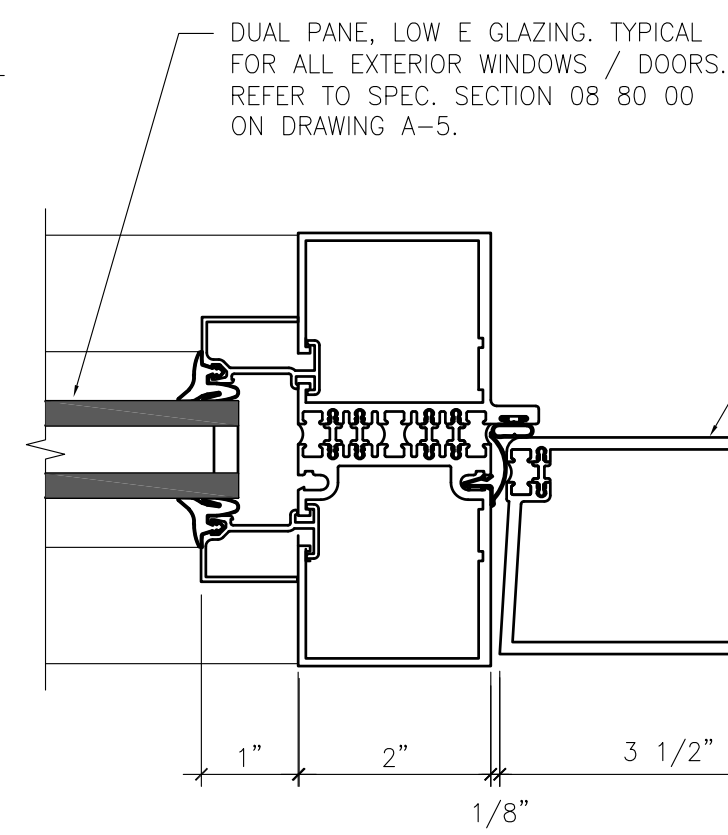

**3 SECTION DETAIL**  
A2 SCALE: 6" = 1'-0"

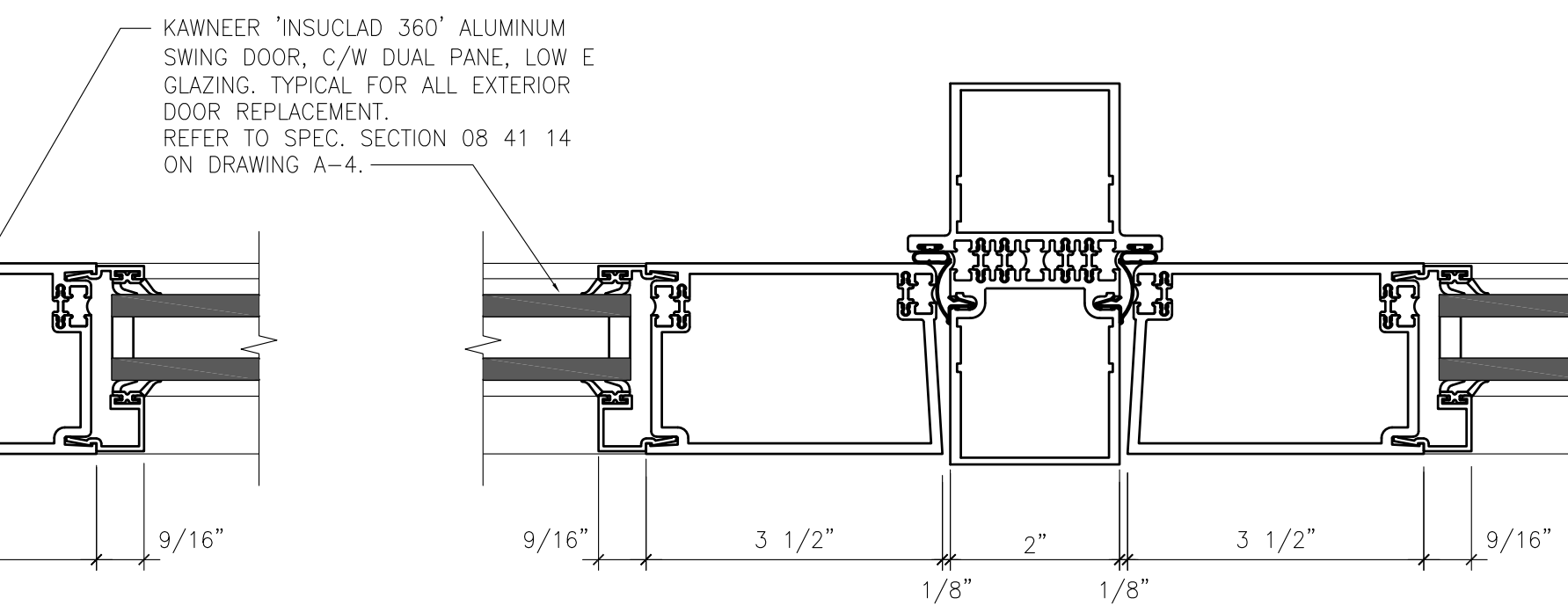

**4 SECTION DETAIL**  
A2 SCALE: 6" = 1'-0"

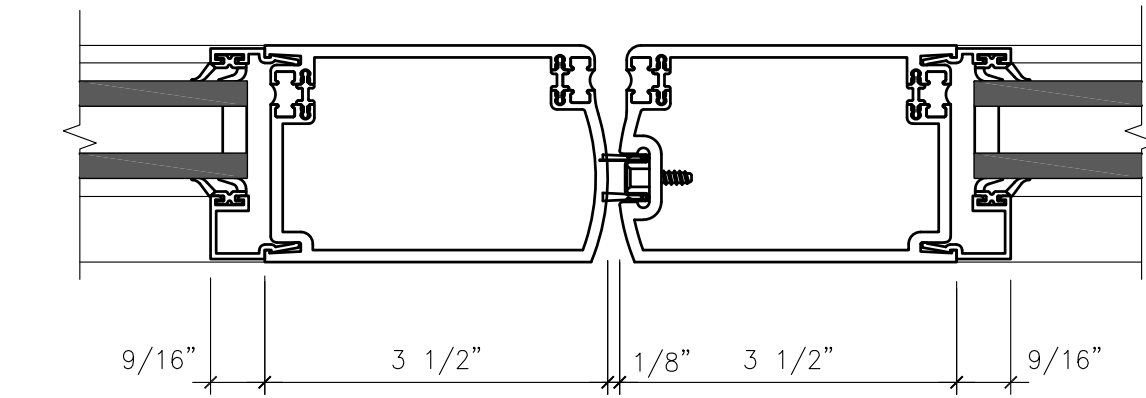

**5 SECTION DETAIL**  
A2 SCALE: 6" = 1'-0"

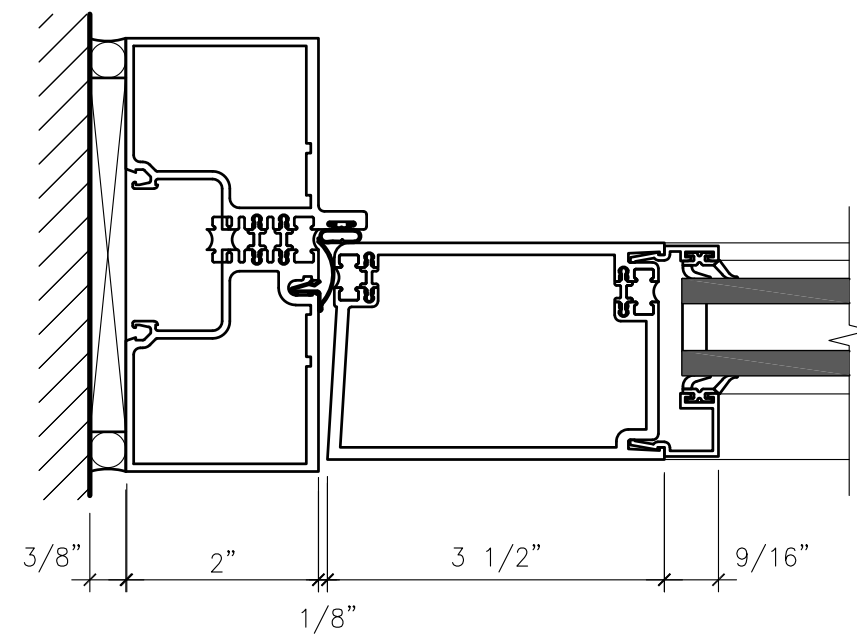

**1A SECTION DETAIL**  
A2 SCALE: 6" = 1'-0"

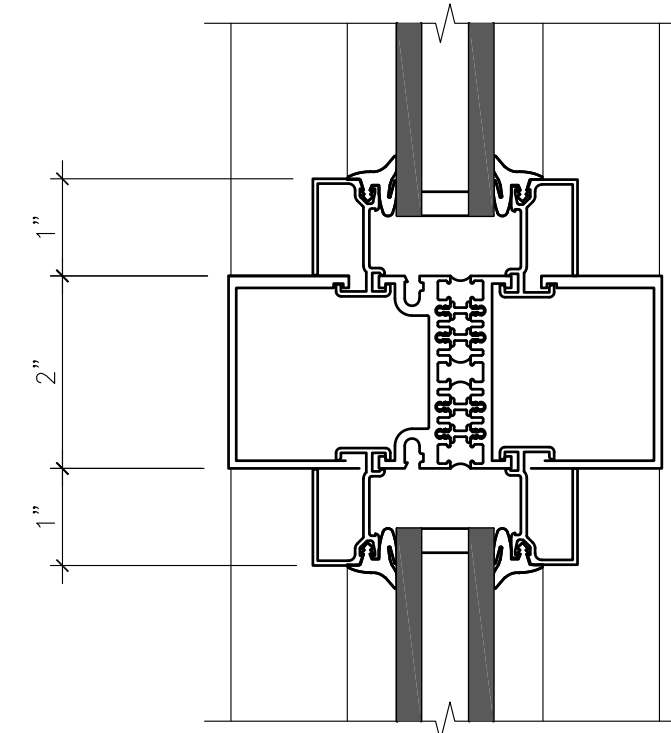

**6 SECTION DETAIL**  
A2 SCALE: 6" = 1'-0"

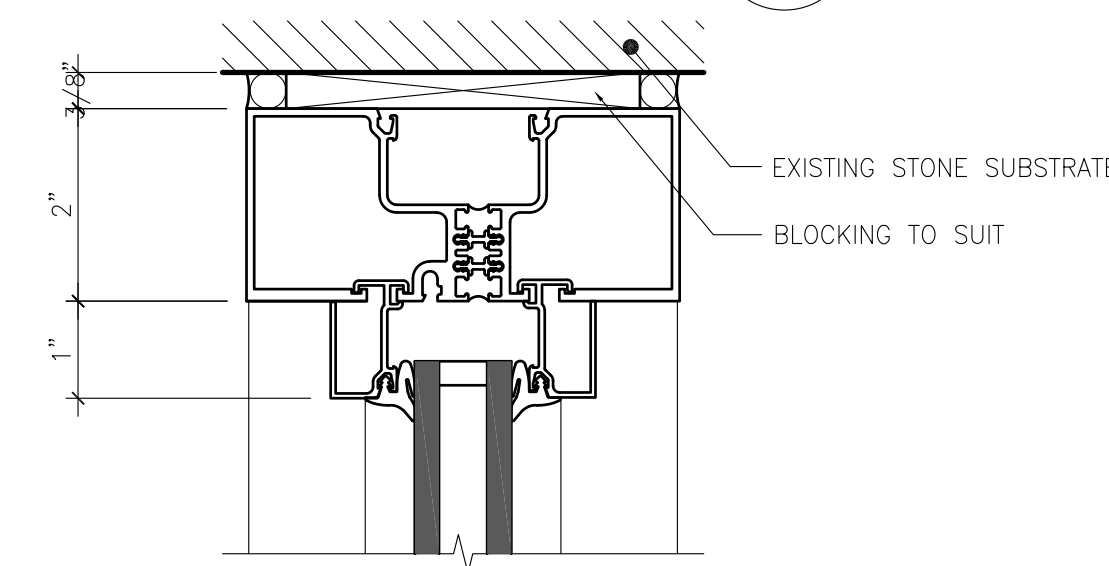

**8 SECTION DETAIL**  
A2 SCALE: 6" = 1'-0"

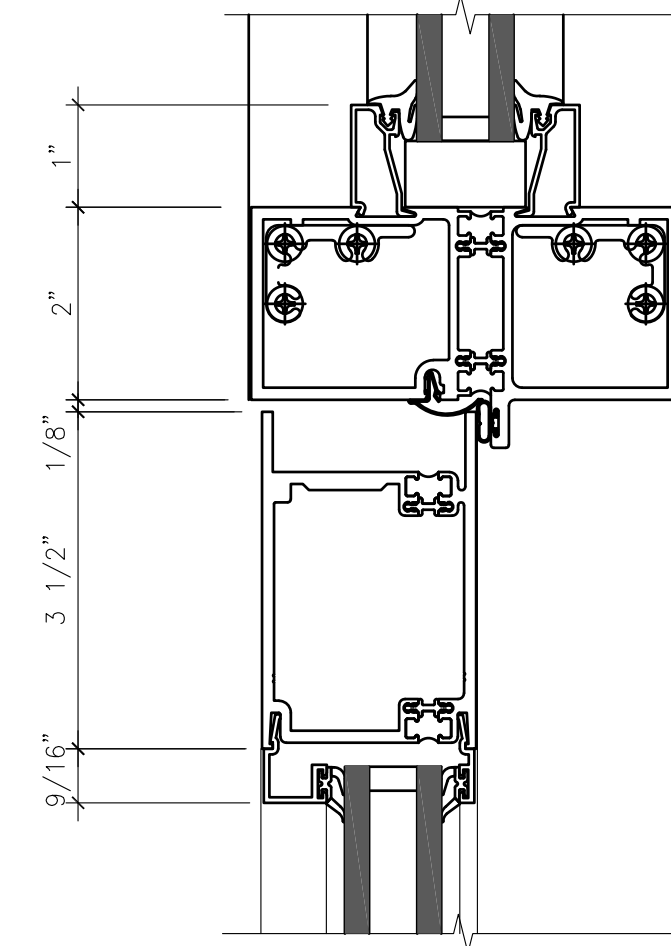

**9 SECTION DETAIL**  
A2 SCALE: 6" = 1'-0"

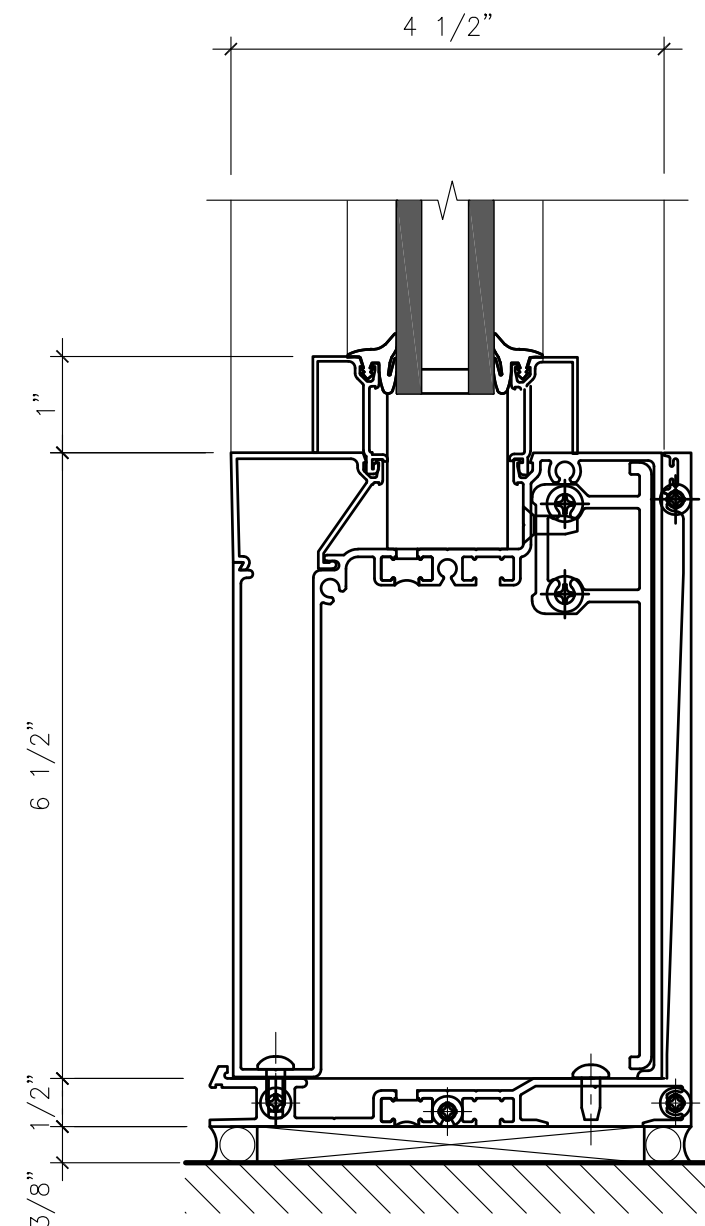

**7 SECTION DETAIL**  
A2 SCALE: 6" = 1'-0"

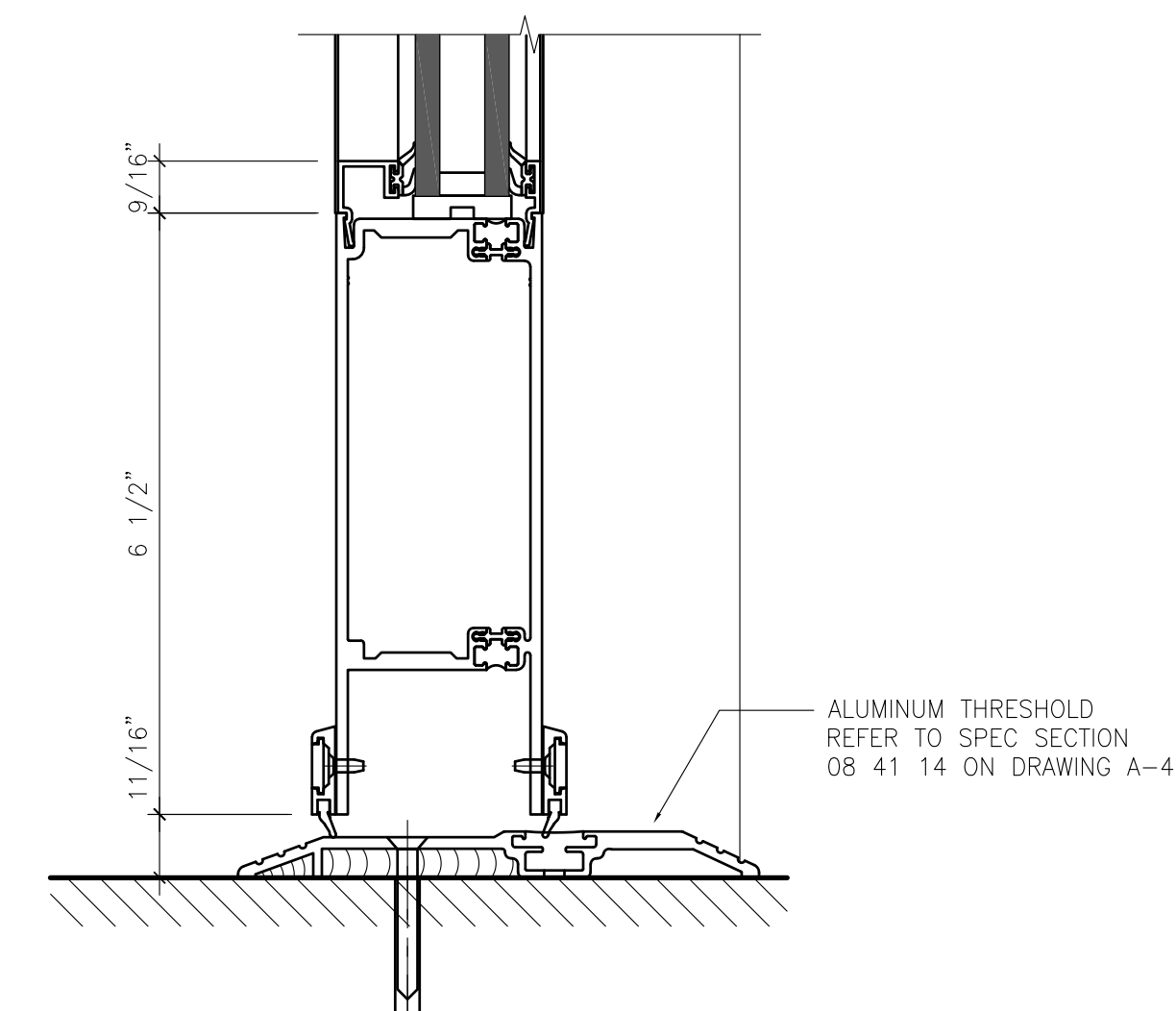

**10 SECTION DETAIL**  
A2 SCALE: 6" = 1'-0"

**ASBESTOS**  
ASBESTOS MAYBE PRESENT BEHIND WALLS, CEILING SPACES & FLOORS. IF ASBESTOS OR ANY HAZARDOUS MATERIAL IS FOUND, STOP WORK IMMEDIATELY AND CONTACT CITY OF WINNIPEG CENTRAL CONTROLS @ 204 986-2351.

No.	REVISION/DESCRIPTION	BY	DATE
0	ISSUED FOR CONSTRUCTION	PS	JUL 15 2024

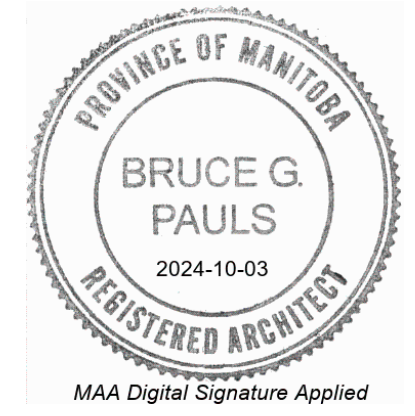

DATE	DESIGNED	DRAWN	CHECKED	APPROVED
2023.11.07	BP / PS	PS	BP	-

THE CITY OF WINNIPEG  
ASSETS & PROJECT MANAGEMENT  
DEPARTMENT  
MUNICIPAL ACCOMMODATIONS DIVISION  
3-65 GARRY STREET, R3C 4K4

PROJECT  
CITY HALL - COUNCIL AND ADMIN. BUILDINGS  
MAIN ENTRANCES - DOOR / WINDOW REPLACEMENT

510 MAIN STREET  
SHEET TITLE  
COUNCIL AND ADMINISTRATION BUILDINGS  
EXTERIOR FRAMING SECTION DETAILS

SCALE	PROJECT No:	SHEET No:
AS SHOWN	2021-111	A3

DRAWING SHEET SIZE: D (24" x 36") PLOT 1:1