

SERVICE EQUIPMENT LAYOUT
SCALE: 1 : 20

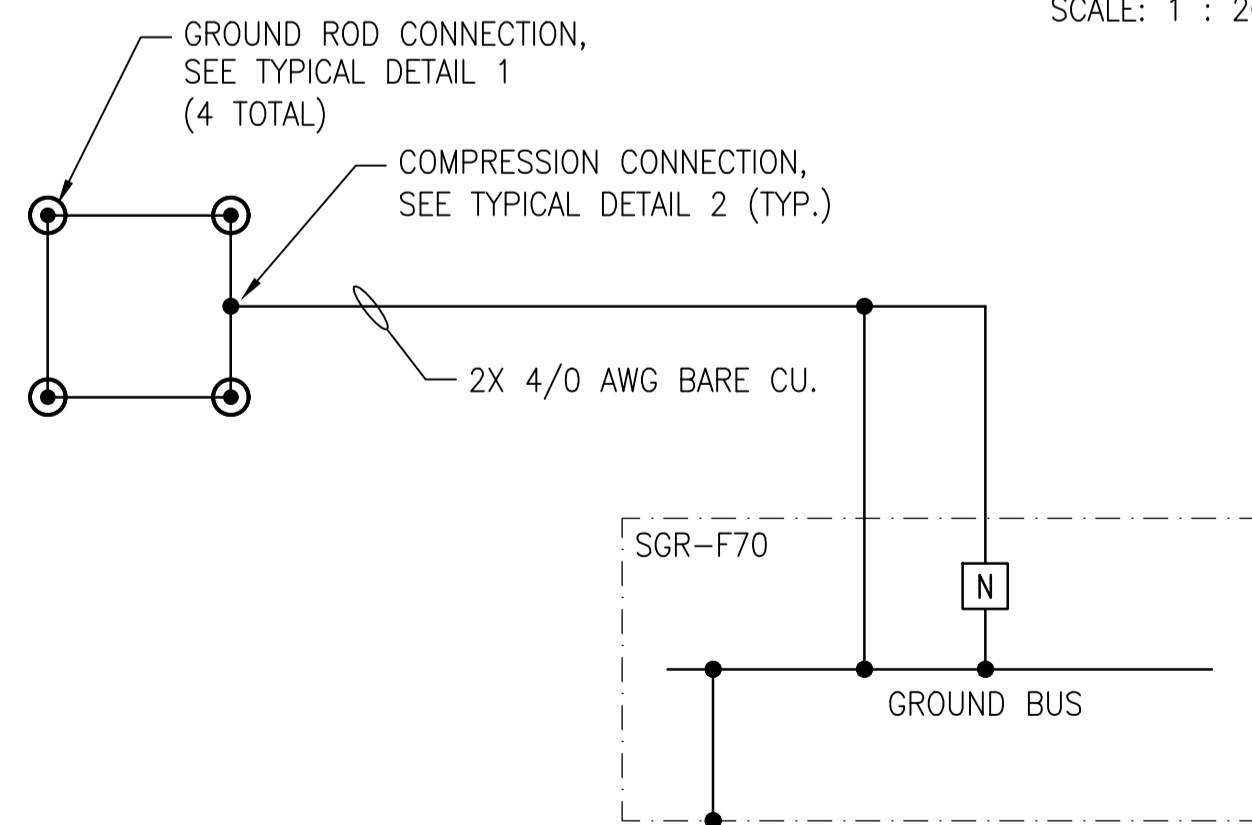

LOW VOLTAGE EQUIPMENT GROUNDING
SCALE: N.T.S.

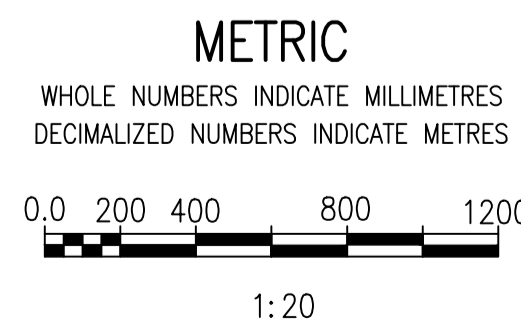

ENGINEERS GEOSCIENTISTS MANITOBA
Certificate of Authorization
AtkinsRéalis Canada Inc.
No. 4489

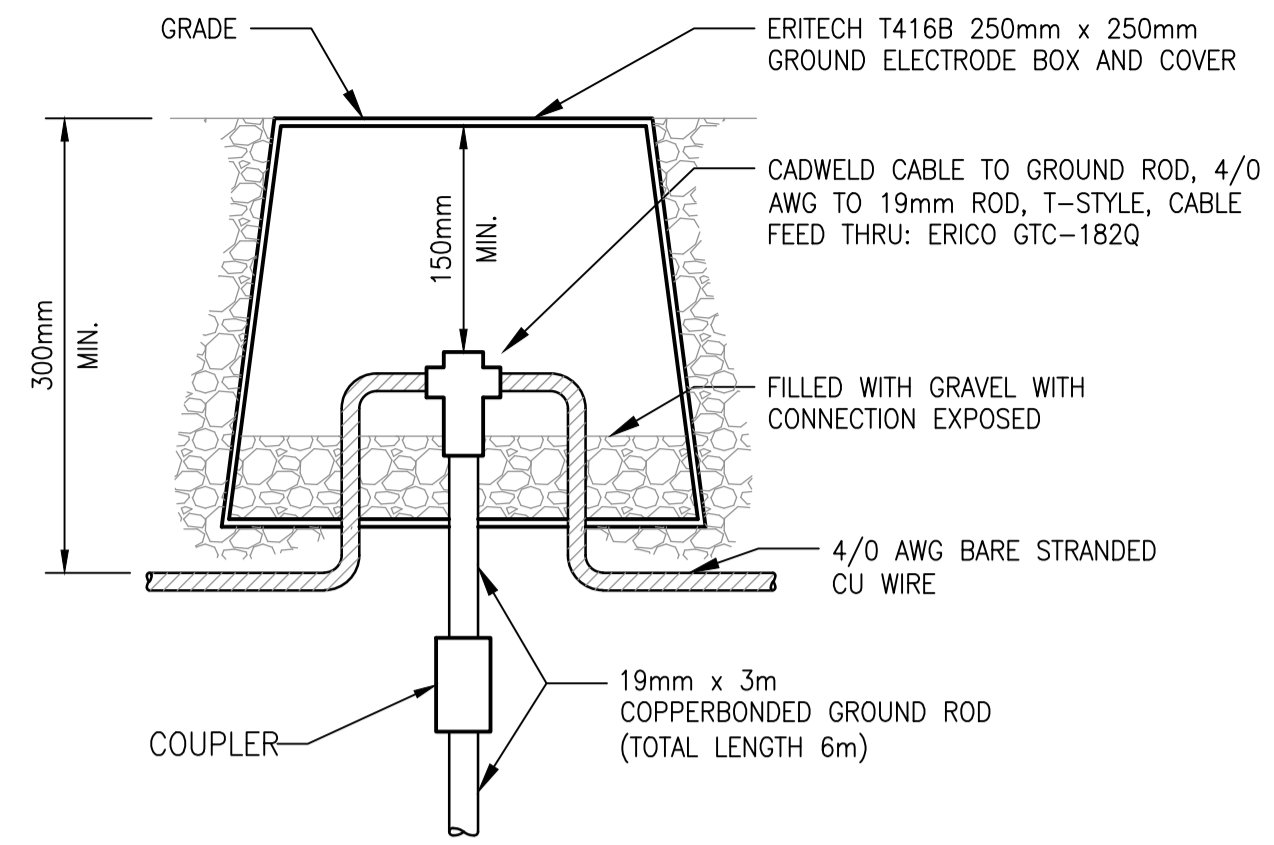

1 GROUND ROD WITH GROUND WELL
SCALE: N.T.S.

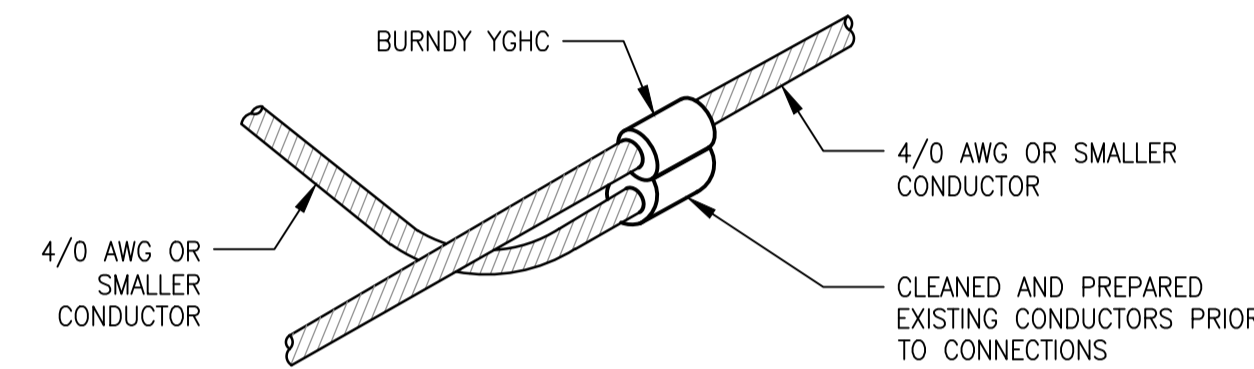

2 GROUND CONDUCTOR SPLICE
SCALE: N.T.S.

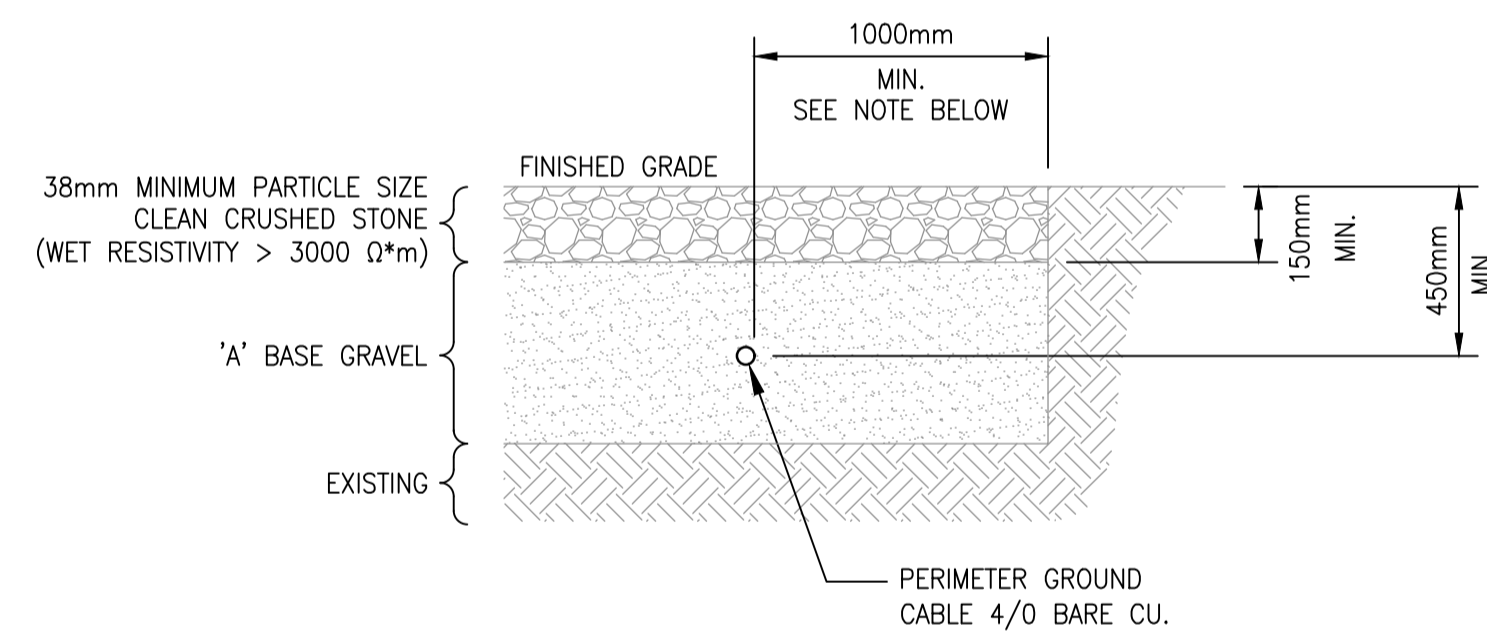

3 PERIMETER GROUND CABLE INSTALLATION
SCALE: N.T.S.
NOTE: CRUSHED STONE AND 'A' BASE MATERIAL TO EXTEND A MINIMUM OF 1000mm PAST PERIMETER GROUND CABLE.

GENERAL NOTES:

- COORDINATE EXACT LOCATION OF CONDUITS WITH EQUIPMENT SHOP DRAWINGS PRIOR TO CONCRETE POUR.
- TRANSFORMER CLEARANCES SHALL BE IN ACCORDANCE WITH CEC RULE 26-242(2)(b)(i).
- PERIMETER BURIED GROUND CABLE AND GROUND RODS SHALL BE INSTALLED AS PER DETAILS 1, 2 AND 3.
- ALL GROUND CABLES ARE BARE 4/0 AWG, COPPER, UNLESS OTHERWISE INDICATED.
- ALL EXPOSED GROUND WIRE SHALL BE ROUTED IN CONDUIT FOR MECHANICAL PROTECTION.
- EQUIPMENT DOOR OPENINGS ARE NOT SHOWN FOR CLARITY.
- ALL 4160 AND 600 VAC POWER CABLING AND CONDUIT IS NOT SHOWN FOR CLARITY. REFER TO OTHER DRAWINGS.

CONSTRUCTION NOTES:

- ALL PERIMETER GROUND CABLES SHALL BE BURIED BELOW FINISHED GRADE. ALL BELOW GRADE CONNECTIONS SHALL BE COMPRESSION OR CADWELDED.
- PROVIDE BOLLARDS (GUARD POSTS) WITH GROUND CONNECTIONS. GROUND CABLE SHALL BE BOLTED ON A WELDED STEEL TAB USING A 2-HOLE NEMA LONG BARREL COMPRESSION LUGS.
- PROVIDE 4/0 AWG BARE COPPER GROUND RUN IN CONDUIT SLEEVE FROM ELECTRICAL EQUIPMENT TO GROUND GRID. PROVIDE TWO (2) SEPARATE GROUNDING CONNECTIONS FOR EACH PIECE OF EQUIPMENT. EQUIPMENT SHALL BE GROUNDED TO TWO (2) DIFFERENT GROUNDING CONDUCTOR RUNS.
- PROVIDE CONDUIT EMBEDDED IN CONCRETE SLAB FOR PRIMARY CABLE FROM THE 5KV SWITCHGEAR SGR-F70. FUSIBLE DISCONNECT TO TRANSFORMER XFMR-F1. EXACT LOCATIONS SHALL BE DETERMINED FROM THE SHOP DRAWINGS OF THE TRANSFORMER AND 5KV SWITCHGEAR. PROVIDE WATERPROOF SEALING OF CABLES AFTER INSTALLATION.
- THE CONDUIT SLEEVES FOR INCOMING AND OUTGOING CABLING SHALL BE EXTENDED 500mm PAST THE EDGE OF THE CONCRETE PAD AND SEALED AROUND THE CABLING.
- PROVIDE WARNING SIGNS IN ACCORDANCE WITH CSA 22.1, RULE 36-006.

LEGEND:

- GUARD POST 120mmØ x1500mm FILLED WITH CONCRETE AS PER CITY OF WINNIPEG DRAWING SCD-135 AND COMPLETE WITH YELLOW PLASTIC BOLLARD COVER.
- - - 4/0 AWG BARE STRANDED COPPER GROUND CABLE
- 6000mm LONG (19mm Ø) COPPER CLAD GROUND ROD WITH GROUND WELL
- CABLE COMPRESSION CONNECTION
- CADWELD OR SERVIT CONNECTION

<p>148 Nature Park Way, Winnipeg, Manitoba Canada R3P 0X7 204-786-8080</p>				ENGINEER'S SEAL	
				<p>THE CITY OF WINNIPEG WATER AND WASTE DEPARTMENT</p>	
<p>DESIGNED BY: P. GILL DRAWN BY: K. MOHAMMED SCALE: AS NOTED DATE: 2024/11/27</p>				<p>CHECKED BY: V. ELIMBAN APPROVED BY: D. BECKER ISSUED FOR CONSTRUCTION BY: B. SOLOWAY DATE: 2024/12/20</p>	
<p>CONSULTANT NO.: 701408</p>				<p>CITY DRAWING NUMBER: 0-0132F-E0003 SHEET: 001 REV: 00 SIZE: A1</p>	
00	ISSUED FOR TENDER AND CONSTRUCTION	2024/12/20	PG	VE	
NO.	REVISIONS	DATE	DESIGN	CHECK	