

McMULLEN CRESCENT

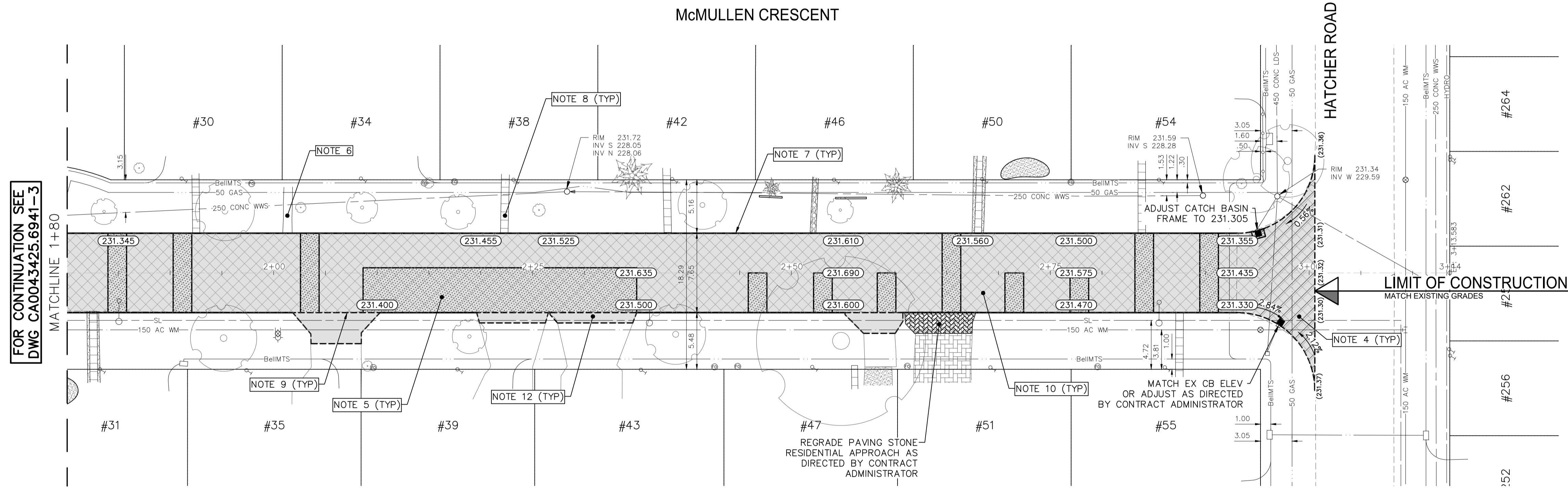

- NOTES:**
1. ALL WORK AND MATERIALS TO BE IN ACCORDANCE WITH THE LATEST REVISION OF THE CITY OF WINNIPEG STANDARD CONSTRUCTION SPECIFICATIONS.
  2. CONTRACTOR TO CONFIRM THE LOCATION OF ALL UTILITIES/SERVICES IN THE FIELD PRIOR TO CONSTRUCTION.
  3. ALL ROADWAY DIMENSIONS SHOWN ARE TO BACK OF CURB.
  4. EXISTING ASPHALT TO BE PLANED AS SHOWN OR AS DIRECTED BY CONTRACT ADMINISTRATOR.
  5. 150mm PARTIAL CONCRETE SLAB PATCHES SHOWN ARE ONLY A REPRESENTATIVE APPROXIMATION OF THE TENDERED QUANTITIES.
  6. EXISTING SIDEWALK TO BE RENEWED AS PER SD-228A AND AS DIRECTED BY CONTRACT ADMINISTRATOR.
  7. PLANE EXISTING CURB AND INSTALL MODIFIED LIP CURB AS PER SD-202C AND AS DIRECTED BY CONTRACT ADMINISTRATOR.
  8. ALL PRIVATE WALKWAYS TO BE ADJUSTED TO NEW SIDEWALK OR TOP OF CURB ELEVATION, AS DIRECTED BY THE CONTRACT ADMINISTRATOR.
  9. EXISTING LIP CURB AT PRIVATE APPROACHES TO BE RENEWED AS DIRECTED BY CONTRACT ADMINISTRATOR.
  10. PAVEMENT REPAIR FABRIC TO BE INSTALLED AS SHOWN OR AS DIRECTED BY CONTRACT ADMINISTRATOR.
  11. MODIFIED BARRIER CURB TO BE CONSTRUCTED AT ALL INTERSECTION RADII AND ALLEY RADII.
  12. OVERLAY EXISTING CONCRETE AND ASPHALT RESIDENTIAL APPROACHES AS DIRECTED BY CONTRACT ADMINISTRATOR.
  13. CONTRACTORS TO TAKE PRECAUTIONARY STEPS TO PROTECT EXISTING TREES WITHIN THE LIMITS OF CONSTRUCTION FROM DAMAGE FROM CONSTRUCTION ACTIVITIES AS OUTLINED IN THE SPECIFICATIONS.
  14. LAMP STANDARDS, HYDRO POLES, AND ANCHORS THAT REQUIRE TEMPORARY SUPPORT, REMOVAL OR REPLACEMENT, TO BE DONE SO AT THE EXPENSE OF THE CONTRACTOR AS NECESSARY.
  15. ALL BOULEVARDS TO BE SODDED UNLESS OTHERWISE NOTED.
  16. ADJUST ALL WATER VALVES, HYDRANTS, MANHOLES, AND CATCH BASINS IN WORK AREA TO GRADE.

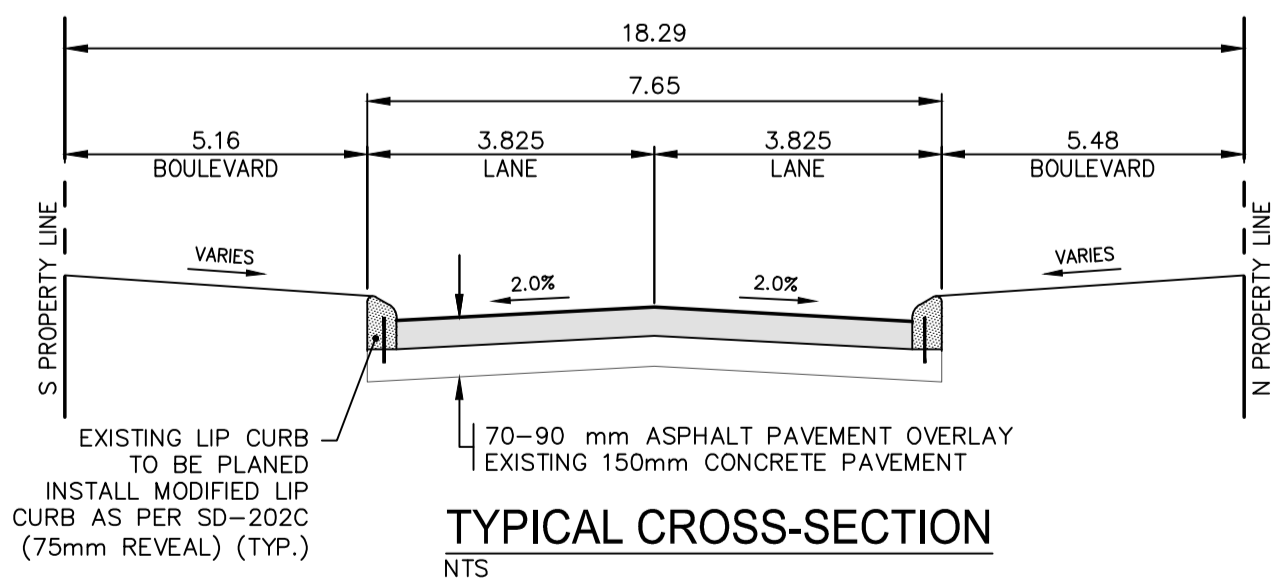

EXISTING	LEGEND-PLAN	PROPOSED	EXISTING	LEGEND-PLAN	PROPOSED	EXISTING	LEGEND-PLAN	PROPOSED
---	WATER MAIN	---	---	VALVE	---	---	EDGE OF SIDEWALK	---
---	LAND DRAINAGE SEWER	---	---	CURB STOP	---	---	EDGE OF ASPHALT	---
---	WASTE WATER SEWER	---	---	HYDRO POLE & LIGHT STANDARD	---	---	EDGE OF CONCRETE	---
---	HYDRO	---	---	LIGHT STANDARD OR TRAFFIC SIGNAL	---	---	MODIFIED BARRIER CURB	---
---	GAS	---	---	HYDRO POLE / ANCHOR	---	---	BARRIER CURB	---
---	COMMUNICATIONS	---	---	FENCE	---	---	BARRIER CURB AND GUTTER	---
---	SIGNALS	---	---	PROPERTY LINE	---	---	PAVING STONE	---
○	MANHOLE	○	○	IRON BAR	---	---	CONCRETE SIDEWALK	---
□	CATCH BASIN/CATCH PIT	□	□	TEST HOLE / PAVEMENT CORE	---	---	CONCRETE SLAB	---
△	CURB INLET	△	△	ELEVATIONS	(231.000)	---	ASPHALT	---
◇	UTILITIES ADJUSTED	◇	◇	CURB RAMP	---	---	MILLED SURFACE	---
◇	HYDRANT	◇	◇	DETECTABLE WARNING SURFACE TILE	---	---	PAVEMENT REPAIR FABRIC	---
---	EXISTING	---	---	LEGEND-PLAN	---	---	LEGEND-PLAN	---
---	PROPOSED	---	---	PROPOSED	---	---	PROPOSED	---

**LOCATIONS APPROVED UNDERGROUND STRUCTURES**

SIGNED BY: \_\_\_\_\_ DATE: \_\_\_\_\_

NO. REVISIONS: \_\_\_\_\_ DATE: \_\_\_\_\_ BY: \_\_\_\_\_

LOCATION OF UNDERGROUND STRUCTURES AS SHOWN ARE BASED ON THE BEST INFORMATION AVAILABLE BUT NO GUARANTEE IS GIVEN THAT ALL EXISTING UTILITIES ARE SHOWN OR THAT THE GIVEN LOCATIONS ARE EXACT CONFIRMATION OF EXISTENCE AND EXACT LOCATION OF ALL SERVICES MUST BE OBTAINED FROM THE INDIVIDUAL UTILITIES BEFORE PROCEEDING

G.S.M. LAMP STANDARD @ 55 McMullen Crescent SOUTH WEST BOLT  
ELEV. 231.587

7	---	---	---
6	---	---	---
5	---	---	---
4	---	---	---
3	---	---	---
2	---	---	---
1	---	---	---
0	ISSUED FOR TENDER	20250208	K.G.
NO.	REVISIONS	DATE	BY

**wsp**

DESIGNED BY: N.T. CHECKED BY: K.G.  
DRAWN BY: K.C.W.D./N.T. APPROVED BY: S.S.

HOR. SCALE: 1:250  
VERTICAL SCALE: 1:10

RELEASED FOR CONSTRUCTION: \_\_\_\_\_  
DATE: DECEMBER 2024

WSP Canada Inc.  
1600 Buffalo Place  
Winnipeg, MB R3T 6B8  
t. 204.477.6650  
f. 204.474.2864  
www.wsp.com

ENGINEER'S SEAL

CONSULTANT ACAD DWG. NO.  
CA0043425.6941-04

**FOR TENDER PURPOSES ONLY**  
**NOT FOR CONSTRUCTION**

**THE CITY OF WINNIPEG**  
PUBLIC WORKS DEPARTMENT  
ENGINEERING SERVICES DIVISION

2025 LOCAL STREET RENEWALS  
MCMULLEN CRESCENT  
MAJOR REHABILITATION  
STA. 1+80 TO STA. 3+00.78

CITY DRAWING NUMBER  
SHEET 04 OF 26

TENDER NO.  
167-2025

**METRIC**  
WHOLE NUMBERS INDICATE MILLIMETRES  
DECIMALIZED NUMBERS INDICATE METRES

**ENGINEERS GEOSCIENTISTS MANITOBA**  
Certificate of Authorization  
WSP Canada Inc.  
No. 5750

Feb 26, 2025 - 2:30pm  
P:\2024\CA0043425.6941 - CA-25-R-07 Local Streets\02 Drawings\03 Work\_Dwg CA0043425.6941\_McMullen Cr\_Plan-Profile.dwg - tab:167-2025\_Drawing\_CA0043425.6941-04-R0