

Notes

- 1. Wood slats: 89x89mm (4x4") composite slats with cedar tone finish
- 2. Frame: welded steel with galv. finish
- 3. Surface mount with min 75mm depth wedge anchors & washers

Drawing Title:

**Tache Bench Composite
with Arms - Surface Mount**

Drawing Number:

SCD-121E

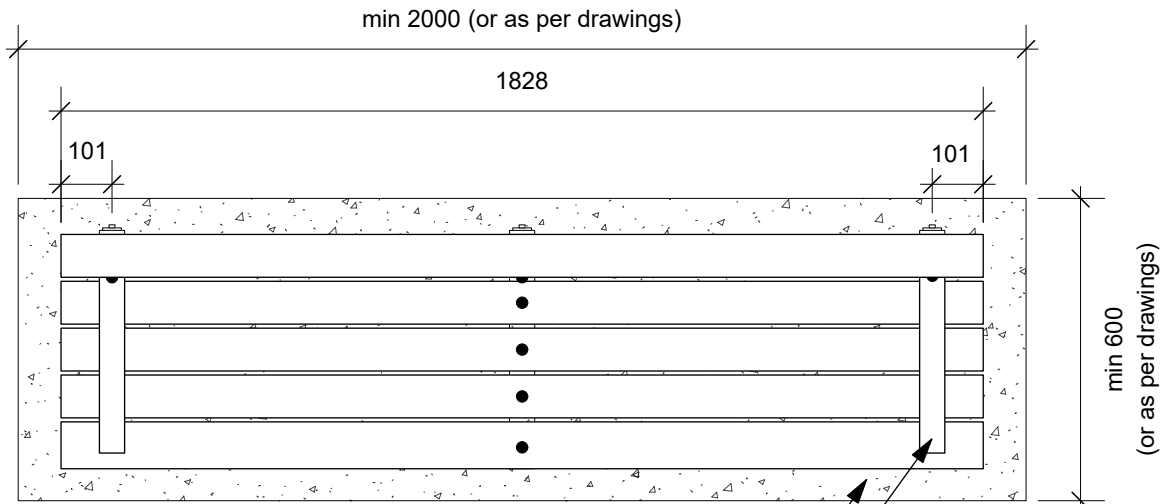

Plan View

concrete surface below
steel arm rest

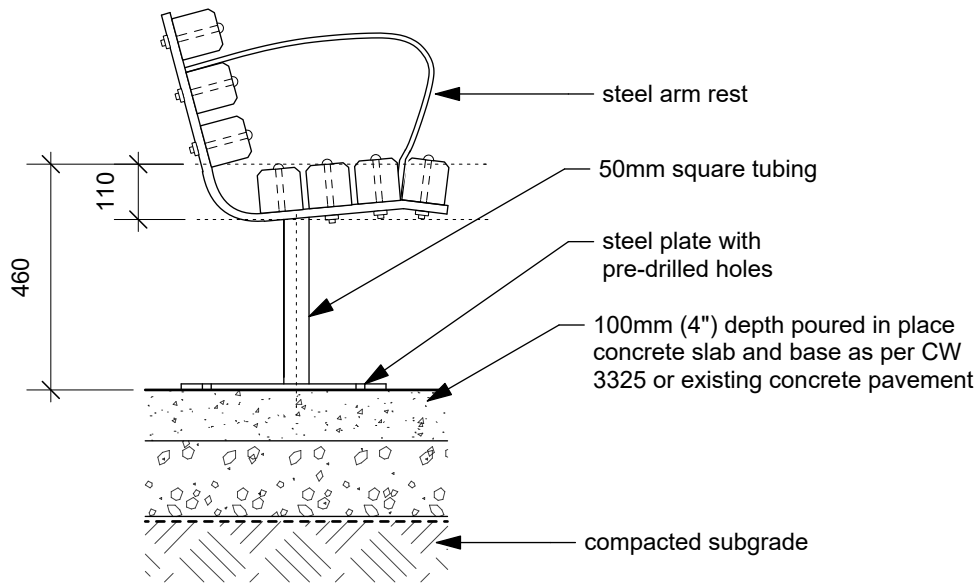

Section

Dimensions shown are in millimetres unless otherwise specified

Revision: 2
Date: January 2026
Scale: NTS
Drawn by: MG

The City of Winnipeg
Planning, Property & Development Department
Urban Planning & Design
Unit 15 - 30 Fort Street, Winnipeg, MB, R3C 4X5

