

SAW CUT FULL-DEPTH PRIOR TO AND FOR THE FULL LENGTH OF CURB REMOVAL

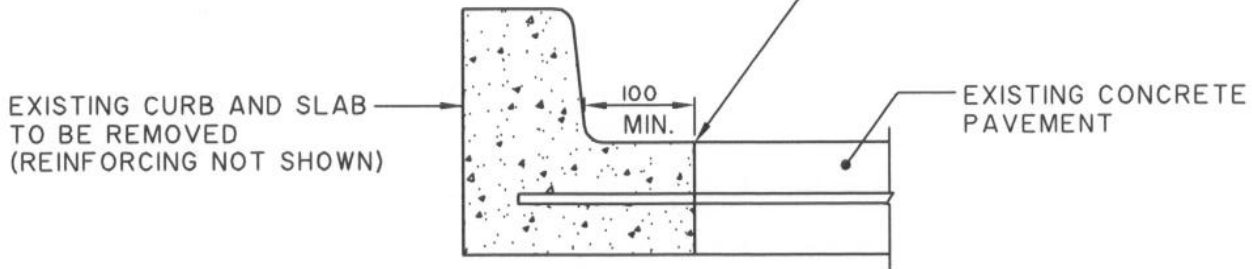

**PAVEMENT REMOVAL FOR BARRIER CURB**

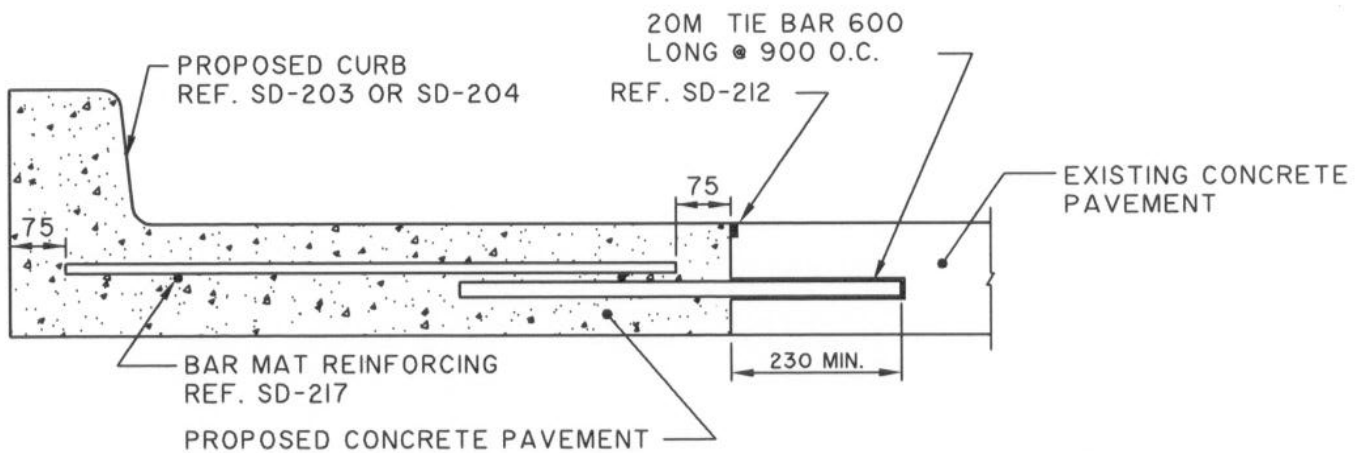

**PAVEMENT WIDENING**

NOTE: TRANSVERSE SAW CUT EVERY 6.0 METRES OR AT PAVEMENT JOINTS.

DIMENSIONS ARE IN MILLIMETRES



**THE CITY OF WINNIPEG**  
PUBLIC WORKS DEPARTMENT

Reference Spec. No.  
CW 3230, CW 3310

Revisions			
No.	Date	Description	By
1.	JAN. 03	GENERAL REVISION	lwb

**CONCRETE PAVEMENT WIDENING**

Designed By: L.S.W.L.	Drawn By: lwb	Scale : <b>N.T.S.</b>
Checked By: D.R.K.	Date: 03-01-28	Drawing No.
Approved: SURFACE WORKS COMMITTEE		<b>SD-207</b>