

Free-Standing Signs Structural Requirements

A guide to the structural requirements for free-standing signs

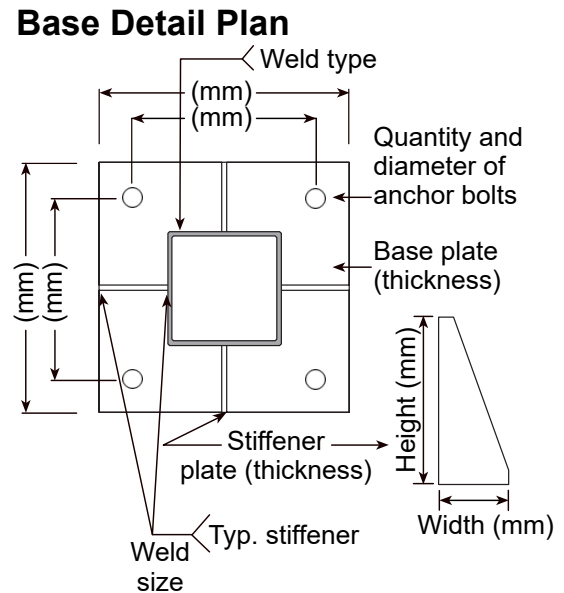
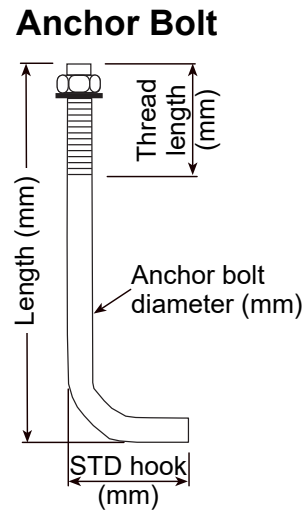
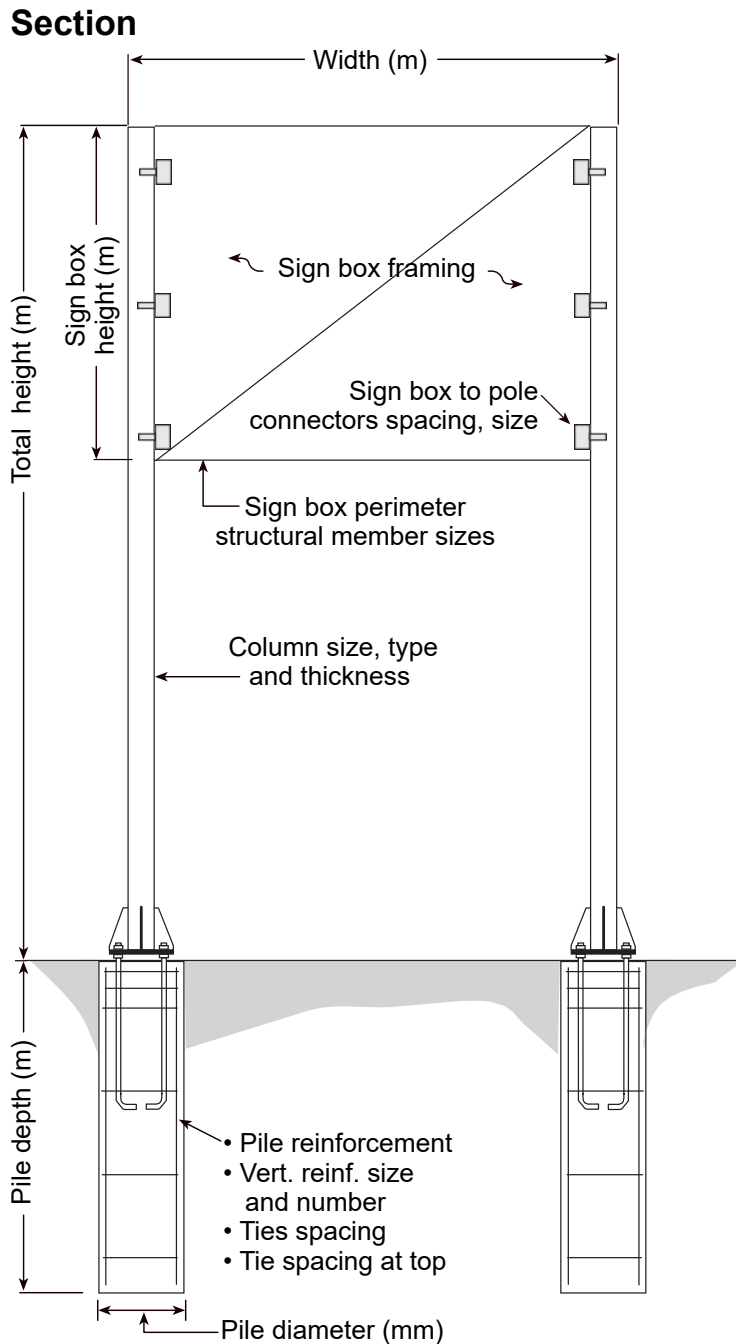

General Notes:

- Design wind = (kPa)
- Steel grade 350W
- All welding to be CSA W59
- Anchor bolt yield strength (MPa)
- Anchor bolt hot dip galvanized
- Concrete pile (MPa), cement type HS
- Soil type: soft, firm, stiff
- Soil lateral resistance capacity (MPa/m)

Sign Address:

Engineer's Seal and
Signature, Date

Structural Requirements

The following information shall be shown on the structural plans for free-standing sign permits:

- Pole size, diameter, depth, spacing, and reinforcement
- Concrete strength (MPa) and cement type HS for S1 exposure
- Pole / pylon / column steel strength, size and type. If hollow steel section, then thickness shall be provided.
- Base plate size and thickness
- Anchor bolt type (ASTM), quantity, lengths, and diameter
- Stiffener plates (if used)
- Weld type and thickness
- Pole height and sign box dimensions
- Sign box structural frame construction
- Sign box connection to poles / columns
- If connection is using bolts, provide bolt size and diameter. If using weld, provide weld size.
- Signs using anchor bolts, welds, etc. shall be engineered and bear engineer's seal and signature
- Signs 2.1 m (6'-11") or more in height shall be engineered
- Signs with a surface area more than 3.0 m² (32 sq. ft.) shall be engineered
- The requirement to provide engineered plans rests with the Authority Having Jurisdiction
- References to applicable codes and standards

Note: separate electrical permits are required for all electrical connections.



Planning, Property & Development
Urbanisme, biens et aménagement

Zoning & Permits Branch

Unit 31 - 30 Fort Street, Winnipeg, Manitoba R3C 4X7 | winnipeg.ca/ppd

Permits Direct Line

204-986-5140 | ppd-permit@winnipeg.ca

Updated: March 2021

Every effort has been made to ensure the accuracy of information contained in this publication. However, in the event of a discrepancy between this publication and the governing City of Winnipeg By-law, the By-law will take precedence.