

Drawing Title:

Drawing No:

RENDEZVOUS ACCESSIBLE METAL FRAME PICNIC TABLE

SCD-123A

MATERIALS

1. FRAME: WELDED STEEL W/ GALVANIZED OR BLACK FINISH
2. WOOD SLATS: 38x38mm AND 38x89mm CLEAR FIR BOARDS W/ SEMI-TRANSPARENT CEDAR STAIN

MOUNTING OPTIONS

1. GRANULAR/ASPHALT PAVEMENT: ON SKIDS W/ 2 DUCKBILL ANCHORS
2. CONCRETE PAVEMENT: NO SKIDS, SURFACE MOUNT W/ BOLTDOWN TABS, MIN 75mm DEPTH WEDGE ANCHORS & WASHERS

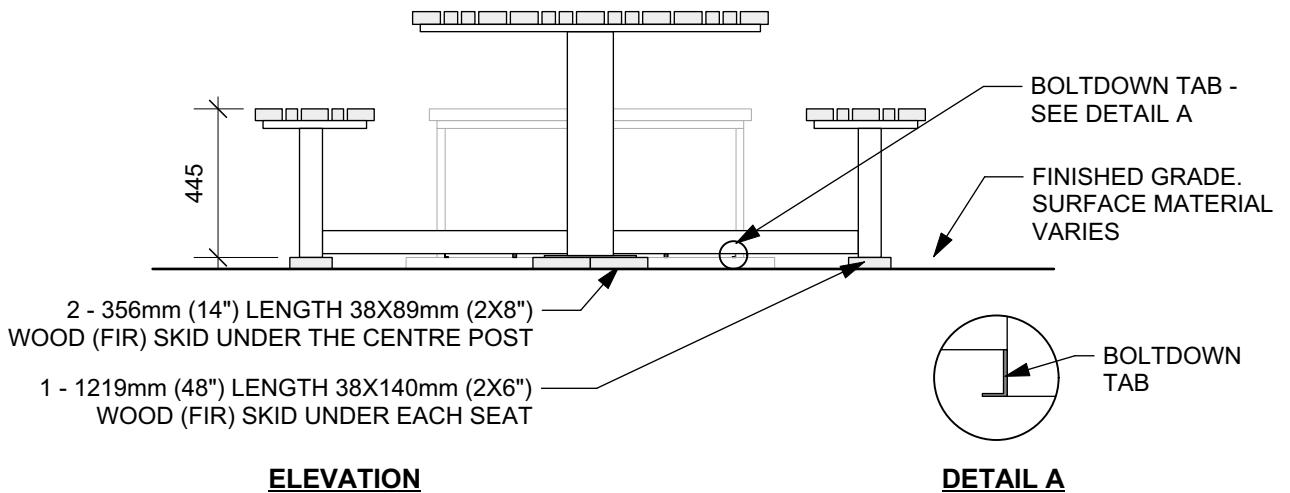
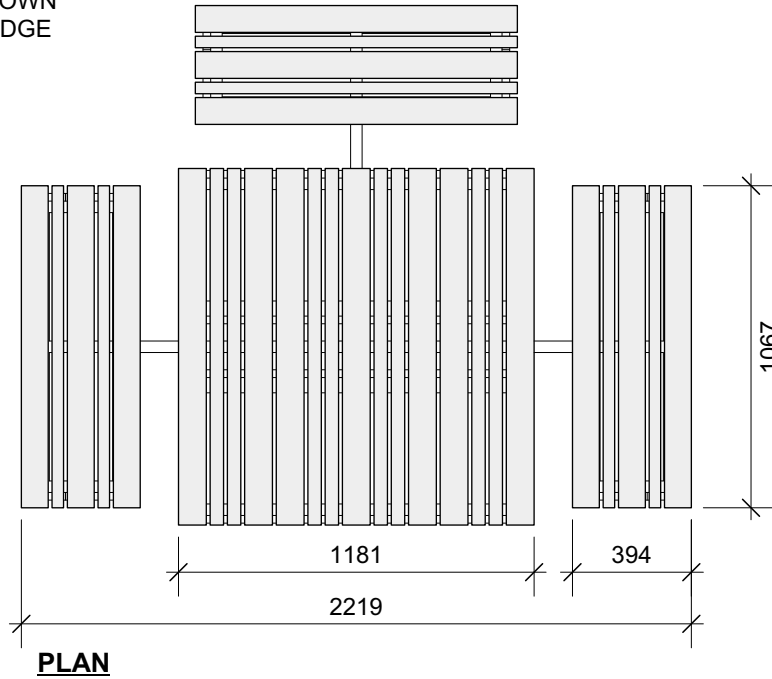

DIMENSIONS SHOWN ARE IN MILLIMETRES UNLESS OTHERWISE SPECIFIED

REVISION:
 DATE: April 2024
 SCALE: N.T.S.
 DRAWN BY: MG

The City of Winnipeg
 Planning, Property and Development Department
 Planning and Land Use Division
 Unit 15 - 30 Fort Street, Winnipeg, MB, R3C 4X5

